

Launch Site

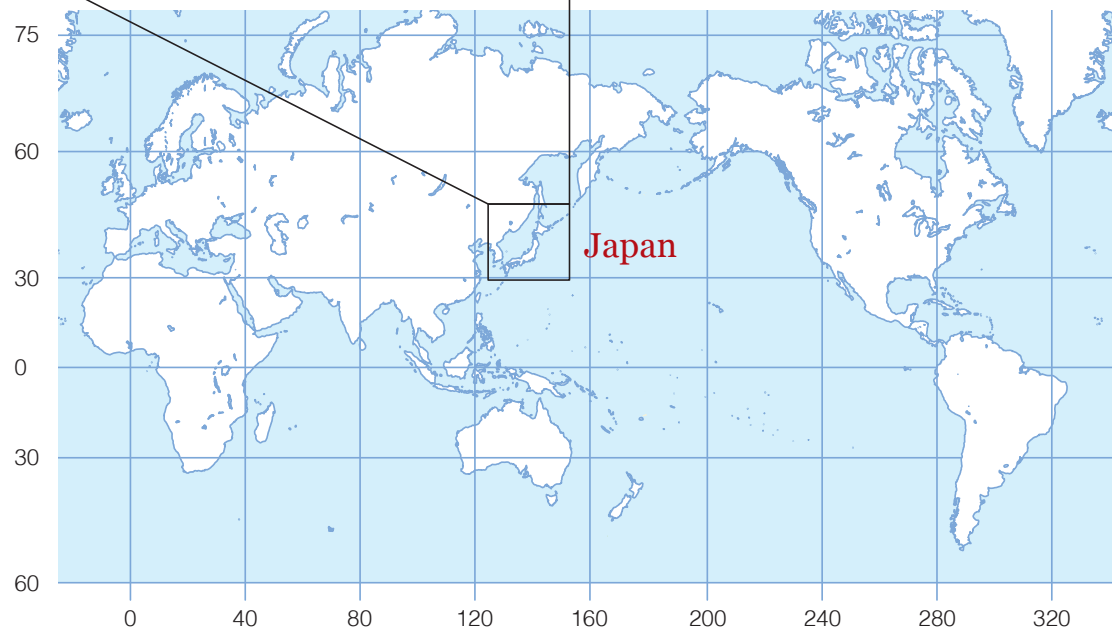
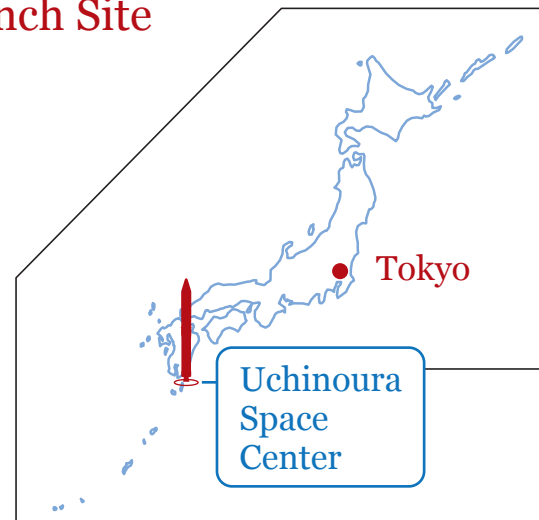

Company Overview

IHI Aerospace Co., Ltd. has been participating in space and defense development in Japan as a leading manufacturer of solid propellant rocket since 1953.

Japan has been carrying out very unique space development and IHI Aerospace Co., Ltd has been playing key role in the development through great contribution primary focused on design, development, and production of rocket systems.

JAXA has been leading the development of Epsilon launch vehicle as an important space project for Japan and IHI Aerospace Co., LTD has been playing the key role in the development as the system integrator based upon such successful heritage.

IHI AEROSPACE Co., Ltd.

Address: Toyosu IHI Bldg., 1-1, Toyosu 3-chome, Koto-ku, Tokyo 135-0061 JAPAN

website <http://www.ihico.jp/ia/en/>

For more information about Epsilon,
Please visit website <http://www.ihico.jp/ia/en/products/space/epsilon/index.html>

TEL: +81(Japan)-3-6204-8015(Direct) E-mail: epsilon.launch@iac.ihico.jp

FAX: +81(Japan)-3-6204-8810

EPSILON

a solid propellant launch vehicle for new age



IHI AeroSpace



EPSILON

a solid propellant launch vehicle for new age

Overview

Epsilon Launch System is a solid propellant launch vehicle suitable for a new age, with high performance and best value. The automatic checkout system can realize the minimum launch campaign period. Epsilon can offer affordable dedicated launch service to customers for small satellites of various LEO,SSO missions such as science, technology demonstration and earth observation.

Technical Heritage

There are two streams of heritage from predecessor rockets, H-IIA/H-IIB and M-V. The technology accumulated in H-IIA/H-IIB and M-V rockets are fully applied for Epsilon development in order to maintain the well-established reliability and to carry out development in a timely manner for reliable launch vehicle development. Ample heritage can be seen in every aspect such as 1st stage, 2nd stage, 3rd stage, PBS, fairing, avionics, guidance system and guidance software etc. Incorporated flight-proven subsystems make Epsilon highly reliable system.

Flight Heritage

As above, the launch vehicle technology, accumulated in 60 years of development and matured in M-V and H Program, has been fully applied to Epsilon. The Epsilon's first flight was successfully conducted with the SPRINT-A onboard on Sep. 14, 2013 from JAXA's Uchinoura Space Center. Now JAXA and IHI Aerospace have launched 4 series and all flight were succeeded. Especially, Epsilon-4 was launched with 7 small satellites on board to demonstrate the new rideshare capability.

H-IIA

H-IIA/H-IIB has been a Japan's flagship launcher for more than 10 years. More than 100 solid-rocket boosters have been flown until now.

M-V

M-V was the largest solid-propellant rocket in the world. 6 flights have been conducted successfully.

M-V Epsilon H-IIA

©JAXA



©JAXA

Vehicle Description

- Three-staged rocket with Post Boost Stage
- Total Length: 26m
- Diameter: 2.6m
- Weight: 96ton
- Payload Adapter: Standard 937mm. Marman-Clamp band type
- Payload Envelope: [Figure1](#)
- Rideshare System: [Figure2](#)

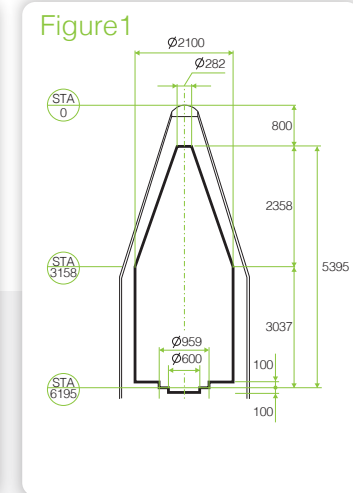
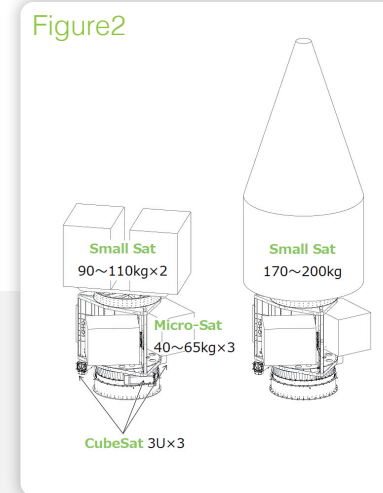

Performance

SPRINT-A ©JAXA

ERG ©JAXA

ASNARO-2 ©NEC

Innovative Satellite Technology Demonstration 1st

Flight	Launch Year	Mission	Mass	Result
1	2013	Hisaki (SPRINT-A)	340kg	Success
2	2016	Arase (ERG)	350kg	Success
3	2018	ASNARO-2	570kg	Success
4	2019	Innovative Satellite Technology Demonstration 1 st	200kg class, 60kg class × 3, 1U,2U,3U CubeSat	Success

Innovative Satellite Technology Demonstration 2nd and 3rd will be launched. Also LOTUSat-1 will be launched by Epsilon S. JAXA and IHI Aerospace is developing the Epsilon S launch vehicle what is aimed at strengthening Epsilon's international competitiveness in the satellite launch market by: (1) demonstrating synergistic effects with the H3 Launch Vehicle; (2) achieving lower launch costs while maintaining high reliability as our mainstay rocket; and (3) refining satellite operability.

Advantages

- Very precise orbit injection by the PBS on the upper stage.
- Comfortable launch environment, the same level as liquid propellant vehicle, with vibration suppression atop of third stage, acoustic blanket in fairing and sophisticated flue in the launch pad.
- Late access for payload down to 3hrs before lift-off
- Minimum launch campaign period less than 2weeks since satellites on board.
- Best total solution for launching small satellites

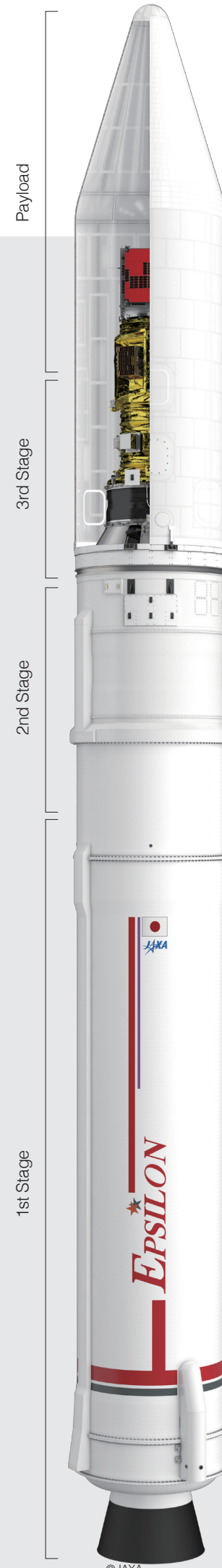

©JAXA