

CONFIDENTIAL

MANUAL  
of the  
AUTOMATIC RIFLE

(Chauchat)

DRILL—COMBAT—MECHANISM.

(Reprint of pamphlet prepared at General Headquarters,  
American Expeditionary Forces, France, March, 1918.



WAR PLANS DIVISION.  
April, 1918

WAR DEPARTMENT,  
Document No. 793  
*Office of the Adjutant General.*



WAR DEPARTMENT,  
WASHINGTON, *April 29, 1918.*

The following pamphlet entitled "Manual of the Automatic Rifle" (Chauchat), is published for the information of all concerned.

(062.1 A. G. O.)

BY ORDER OF THE SECRETARY OF WAR:

PEYTON C. MARCH,  
*Major General, Acting Chief of Staff.*

OFFICIAL:

H. P. McCAIN,  
*The Adjutant General.*



## TABLE OF CONTENTS

	Page.
Part I.—ORGANIZATION.....	7
EQUIPMENT.....	7
Part II.—DRILL.....	9
Part III.—COMBAT PRINCIPLES.	
Chapter I. Characteristics of automatic rifles..	17
Chapter II. Automatic rifles in defense.....	20
Chapter III. The attack—Trench warfare.....	26
Chapter IV. Open warfare.....	38
Part IV.—MECHANISM.	
Chapter I. Description and nomenclature.....	41
Chapter II. Operation of the rifle.....	45
Chapter III. Stoppages.....	62
Chapter IV. Dismounting and assembling.....	69
Chapter V. Care of rifle and magazines.....	70
Chapter VI. Cartridges and magazines.....	71



	French cart.	American cart.	Pistol cart.	Weight
<b>No. 1 Carrier:</b>				
Rifle and bayonet with scabbard.....				11.0 lbs.
Belt, canteen, 1st aid.....	40	60		11.3 "
Bag (musette) with 6 magazines and a packet of 64 cartridges.....	172			17.0 "
Pick mattock and carrier.....				3.0 "
Haversack and rations.....				7.8 "
Total.....	212	60		50.1 lbs.
Pack.....				13.0 "
Aggregate.....				63.1 lbs.

<b>No. 2 Carrier:</b>				
Rifle and bayonet with scabbard.....				11.0 lbs.
Belt, canteen, 1st aid.....	40	60		11.3 "
Bag (musette) with 6 magazines and a packet of 64 cartridges.....	172			17.0 "
Shovel and carrier.....				2.5 "
Haversack and rations complete.....				7.8 "
Total.....	212	60		49.6 lbs.
Pack.....				13.0 "
Aggregate.....				62.6 lbs.

<b>No. 3 Gunner:</b>				
Auto-rifle with sling and cover.....			21	21.0 lbs.
Pistol, holster, magazine and pouch.....				4.5 "
Mounted belt, canteen, 1st aid.....	80			10.4 "
Bag (musette) with 5 magazines and cleaning kit.....	90			12.3 "
Haversack and rations complete.....				7.8 "
Total.....	170		21	56.0 lbs.
Pack.....				13.0 "
Aggregate.....				69.0 lbs.

<b>No. 4 Corporal:</b>				
Pistol, holster, magazine and pouch.....			21	4.5 lbs.
Rifle, bayonet and scabbard.....				11.0 "
Mounted belt, canteen and 1st aid.....		80		10.4 "
Bag (musette) with 6 magazines.....	108			12.5 "
Wire cutter and carrier.....				1.0 "
Haversack and rations complete.....				7.8 "
Total.....	108	80	21	47.2 lbs.
Pack.....				13.0 "
Aggregate.....				60.2 lbs.

<b>Sergeant:</b>				
Pistol, magazine and pouch.....			21	4.5 lbs.
Rifle, bayonet and scabbard.....				11.0 "
Mounted belt, canteen, 1st aid.....		80		10.4 "
Haversack and rations complete.....				7.8 "
Total.....		80	21	33.7 lbs.
Pack.....				13.0 "
Aggregate.....				46.7 lbs.

## RESUME OF AMMUNITION CARRIED BY A SQUAD.

	Magazines	French cart.	American cart.	Pistol cart.
2 No. 1 carriers.....	12	424	120	
2 No. 2 ".....	12	424	120	
2 Gunners.....	10	340	"	42
1 Corporal.....	9	108	80	21
	40	1296	320	63



## PART II

### DRILL

#### 3. Definitions:

"Rifle Team" consists of a gunner, who is team commander, and two carriers (a leader and a scout).

"Squad" consists of two rifle teams and a corporal:

*Front Rank.*—No. 1 Carrier (scout); No. 2 Carrier (loader); No. 3 Gunner; No. 4 Corporal.

*Rear Rank.*—No. 1 Carrier (loader); No. 2 Gunner; No. 4 Carrier (scout).

"Section" consists of two squads and a sergeant.

"Short String" is a burst of two or three cartridges.

"Long String" is a burst of from four to six cartridges.

"Clip Fire" is a burst of eighteen cartridges, or the entire magazine without pause.

4. The training of the auto-rifle section has four phases:

- (1) The individual instruction of the gunner.
- (2) The training of the rifle team.
- (3) The training of the squad.
- (4) The training of the section.

#### 5. Selection of the automatic rifleman:

All members of the Automatic Rifle Section must be healthy, robust men. No other type will be able to carry the loads and meet the demands that will be made upon them. They must be intelligent and must be expert shots. Otherwise, the great fire power which is put in their hands will be wasted.

#### 6. Individual training:

The sergeant, corporal, the gunner and the two ammunition carriers should receive the same instruction, so that all are able to act as gunners and anyone of the section can continue the service of the rifle if the others should be killed. The individual instruction should cover the following:

- (1) The nomenclature and a thorough understanding of the mechanism of the rifle.



- (2) Stoppages and their reduction.
- (3) Correct firing positions.
- (4) Shooting single shots for a group.
- (5) Placing of the group of single shots in the center of target.
- (6) Shooting short strings of 3 shots.
- (7) Long strings of 5 or 6 shots.
- (8) Clip fire.
- (9) Changing magazines.
- (10) Fire at disappearing silhouettes with both short and long strings.
- (11) Firing without looking through the sights as a preparation for "marching fire."
- (12) Marching fire.
- (13) Filling magazines.
- (14) Target designation and the preparation of range cards.

#### 7. The automatic rifle team:

The rifle team must be so trained as to get a maximum of efficiency out of the efforts of the individual members. This requires coordination of all their activities. The training should include the following:

- (1) Drill. The taking of the different formations, and the duties of the gunner and ammunition carriers.
- (2) Utilization of the ground and the disposition of the team on different terrain.
- (3) Service of the rifle by two members of the team.
- (4) Changing of magazines by No. 2 carrier. Loading of empty magazines by No. 1 while in position.
- (5) Advance of the team as a whole.
- (6) Advance of the team by rushing forward one man at a time.
- (7) Opening and ceasing of fire by signal of No. 1 carrier.

8. For the efficient service of the auto rifle, a team of three men is required—a gunner, a loader, and a scout—the gunner being team commander. In an emergency, however, the gun may be kept in action by two, or even one man, and for this reason it is essential that each man be familiar with the duties of every other member of the team. For drill, the team is formed in single rank, right to left, scout, loader, gunner, or loader, gunner, scout. The team deployed occupies the same relative positions with 5 paces as the normal interval.



### 9. The sling:

The ordinary rifle sling, with the addition of two snaps, may be used with the auto rifle.

To adjust the sling, place one snap in the loop made by the short strap, and place the other snap in the loop made by the long strap, and fasten snaps in front and rear sling swivels, respectively. Adjust the large loop to fit over the left shoulder and under the right arm. The size of this loop should remain fixed after once being adjusted; all changes for other positions being made on the short strap.

For close order, the sling should be of such a length as to allow the rifle to be carried behind the right shoulder, with the sling passing over the right shoulder only. For extended order, the rifle is always slung as for marching fire. The rifle should be so slung at any preparatory command for marching.

During the execution of the manual, the rifle is kept at the order arms.

### 10. Firing positions:

*Prone.*—In the prone firing position, the front part of the rifle is supported by the bipod, the barrel bisecting the angle between the legs, which are inclined to the rear as far as the mechanism will allow. The butt is held firmly in the hollow of the right shoulder, the right hand on pistol grip, the left hand on carrying handle, the right cheek firmly against barrel cover, in front of the rear screw collar. The body is placed as nearly as possible in prolongation of the line of sight. The right hand exerts an upward and backward pressure, the left hand a downward and backward pressure. Note: men with high cheek bones will find it necessary to incline the body to the left in order to get a correct sight.

The loader places himself on the right of and on a line with the gunner, his body parallel to the line of sight.

The scout places himself five yards to the right or left of the his gun.

### 11. Marching fire:

The rifle is supported by the sling, which passes over the gunner's left shoulder and under his right arm (for adjustment of sling see paragraph 9).

The gunner grasps the carrying handle with his left hand and the pistol grip with his right hand, and exerts a downward and outward pressure. The butt is held against the front of the right hip. The body is bent well forward from the waist.



The loader marches to the right rear of the gunner, his left hand on the gunner's right shoulder.

The scout marches five paces to the right or left of the rifle.

## 12. Duties of members of the rifle team in prone fire:

*The gunner.*—(1) To direct his fire on the target.

(2) In loading, to pull the operating handle back and cock the rifle, at the same time turning the barrel slightly to the left without lowering it from his shoulder.

(3) In changing magazines, same as sub-head two, and in addition, to press forward on the magazine catch with his left thumb, releasing empty magazine.

(4) When firing alone, to pull back operating handle and cock the rifle, drop the butt to the ground turning the barrel to the left, at the same time pressing the magazine catch forward with the left thumb, removing the magazine with the right hand; to insert a new magazine with the right hand, exerting slight pressure on the magazine catch with the left thumb, until the magazine is firmly seated.

*The loader.*—(1) To watch for signals to commence or cease firing and to transmit same to gunner by two taps on the shoulder.

(2) To watch the ejection opening for stoppages during firing and to aid in reducing same.

(3) To watch the magazine for stoppages, and, when same is empty, to notify the gunner by calling "magazine," withdrawing the empty magazine with the left hand.

(4) To remove empty magazine with the left hand and insert the new magazine by grasping it in his right hand, placing the magazine spring stop between the side plates, behind the bipod transom and shoving magazine home with a sharp upward motion, care being taken not to damage the magazine. Throughout this operation he steadies the rifle by placing his left hand on the housing, behind the rear sight.

(5) When his own magazine bag is empty, to exchange with the Scout and Corporal successively. (The gunner's ammunition is kept as a reserve.)

(6) To carry the hand extractor available for immediate use during fire.

*The scout.*—(1) To exchange magazine bag with the loader.

(2) To fill empty magazines.



- (3) To spot shots for the gunner.
- (4) To act as scout and protect the rifle team when the rifle is out of action.

The duties of the members of the rifle team are the same in marching fire as when firing prone. The loader is responsible for keeping the gunner on the line and preserving the interval.

13. The following drill should be given to insure the gunners cocking the rifle at each loading operation and may be used in any class of fire:

- (1) Load.
- (2) Fire.
- (3) Magazine.

At the first command the gunner cocks the rifle. The loader inserts an empty magazine. The gunner then lays on the target. At the second command the gunner pulls the trigger. At the third command, the gunner cocks the rifle, releases the magazine and turns the barrel to the left, keeping it at his shoulder. The loader removes the magazine and inserts another. The last two commands are repeated as long as the instructor desires.

**14. Being deployed, to commence firing:**

- (1) Range, two hundred (three hundred, etc.).
- (2) Target, skirmish line, at one o'clock.
- (3) Short strings (long strings, or clip fire, etc.).
- (4) Commence firing.
- (5) Cease firing, or suspend firing.

At the first command the team assumes the prone firing position as explained in par. 10, and the gunner sets the sights. At the second command the gunner lays on the target. During the firing the team performs the duties as explained in par. 12. At "Cease Firing" the magazine is removed, the gunner pulls the trigger, and turns the barrel to the left, dropping the butt to the ground. In other respects the team maintains the prone position. At the command "Suspend Firing," firing stops; rifles are held, loaded and locked, in a position of readiness for an instant resumption of firing, rear sights unchanged.

**15. Being deployed, to lie down. Lie down:**

*The gunner:* (1) Advances the left (right) foot and drops on the



right (left) knee, swinging the "bipod legs" well to the front and dropping them to the ground.

(2) Drops butt to the ground, and shoots both legs to the rear, supporting himself on his right (left) elbow and by his grip on the handles.

(3) Turns barrel to the right and disengages front snap. (Whenever sling is adjusted for marching fire.)

(4) Assumes prone firing position, cocking rifle.

*The loader:* (1) Jumps immediately to the side of the gunner and drops to the ground, swinging ammunition bag well to the front.

*The scout:* (1) Closes at once to five yards from the gun and drops to the ground, swinging ammunition bag well to the front.

#### 16. Being deployed, to commence marching fire:

(1) Marching Fire.

(2) Commence firing.

(3) Cease firing.

At the first command, the gunner brings his rifle to the marching fire position and cocks it. The loader jumps to the side of the gunner and inserts a loaded magazine. The scout closes to five yards. At the second command, team steps off (if halted), and commences firing. The loader keeps his left hand on the gunner's right shoulder to steady him, to prevent his halting and to preserve the alignment. At the command "Cease firing," the magazine is withdrawn from the rifle and the loader and scout assume their normal intervals.

#### 17. The squad:

The squad drills in close and extended order as prescribed in the I. D. R., except as herein stated.

#### 18. Duties of the corporal:

(1) To watch for signals from section or platoon leader, and repeat same back:

(2) To assign rifle positions, sectors of fire, and to designate targets.

(3) To exercise general supervision over rifle teams.

#### 19. Being in line, to deploy:

(1) As skirmishers.

(2) March.



The corporal places himself in front of his squad, if not already there. Moving at a run, the front rank men place themselves abreast of, and on the right of the corporal at 5 paces intervals, the rear rank men place themselves abreast of and on the left of the corporal at 5 paces intervals.

**20. Being deployed, to advance by rushes:**

**(1) By team (one man) rush:**

The squad leader gives the signal "advance by rushes" as prescribed in the I. D. R., and, in addition, holds up one finger if the advance is to be made one man at a time, and three fingers spread if it is to be by team. If the advance is by team, the whole team rushes forward at once, maintaining their normal intervals. If the rush is by one man, the scout is the first to go forward. He advances to the position he wishes to occupy, taking advantage of all cover afforded by the terrain or by intervening shell-holes. In general, this advance should not be more than fifty yards. With his intrenching tool he prepares a position for the gun and then signals to the gunner "Ready." The gunner then advances in the same manner and opens fire as soon as his gun is in position, the scout serving the rifle until the loader arrives. The loader after picking up all magazines, advances. If the advance is made from a trench or a shell hole each man should leave from a different point, as a sniper might train his sights upon any fixed point of departure, shooting each member as he appears, successively.

**21. Being in skirmish line:**

**(1) Squad columns.**

**(2) March.**

Each squad leader moves to the front, followed in succession by the front and rear ranks in single file.

**22. Continuous fire:**

**(1) Continuous fire.**

**(2) Commence firing.**

**(3) Cease (suspend) firing.**

At the second command, the gunner on the corporal's right opens fire. Just before his magazine is exhausted, the loader gives the signal "Commence Firing" to the other team, the rifles thus alternating fire.



23. When firing from shell holes, no fixed regulations can be prescribed, the members of the team conforming as nearly as possible to the positions laid down in par. 9.

In case of two rifles advancing singly, the advance of one is covered by the fire of the other.

#### 24. The section:

The section executes the movements and firings as explained for the Team and Squad. The section leader normally takes post in rear of the center of his section, but he may go wherever his presence is needed.

25. Except in "marching fire," the section will seldom act as a unit, but rather as two squads whose action will be supervised by the sergeant of the section. The duties of the sergeant will thus usually be those pertaining to fire direction rather than fire control. The sergeant, under the orders of the platoon leader, will be responsible for the training of the section.

#### 26. Being in skirmish line: |

- (1) Section column of two.
- (2) March.

The section leader moves forward through the center of the section. The squad to the right of the section leader marches to the left and follows him in file, the squad to the left marches in like manner to the right. Each section leader then conducts the march of his section in double column of files.

#### 27. Being in skirmish line:

- (1) Section column of files.
- (2) March.

The section leader moves forward through the center of the section; the squad to the right of the section leader marches to the left and follows him in file; the squad to the left marches to the right and follows the right squad in file.



PART III  
COMBAT PRINCIPLES

CHAPTER I.

28. Characteristics of automatic rifles:

A clear understanding of the characteristics of automatic rifles is absolutely necessary to their correct tactical use. A confusion of ideas as to their powers and limitations will lead to a failure to utilize them to the fullest extent, or to positive disaster by expecting from them functions which they are not capable of performing. The confusion of the words *machine gun* and *automatic rifle* has been responsible for a great amount of erroneous teaching.

An *Automatic Rifle* is a rifle which fires infantry ammunition on the automatic principle, but its recoil is supported by the body of the firer.

A *Machine Gun* is a gun that fires infantry ammunition on the automatic principle, but its recoil is supported by some sort of a fixed mount, and the direction of the fire is capable of being clamped.

The automatic rifle is carried with the infantry in the assault. It is placed in the first line of trenches. It is used under all circumstances with the infantry, as well as in any other situation where an intense infantry fire of short duration, or limited bursts of infantry fire, may be required.

29. Types of automatic rifle:

From the point of view of the method of operation, there are two general classes of automatic rifles:

(1) Those operated by the direct recoil.

The Chauchat and light Maxim are examples of this type.

(2) Those operated by a small portion of the gas passing through a port and acting on a piston or actuator.

The Lewis, light Hotchkiss and Benet-Mercier are examples of this type.

Considered from the point of view of the method of cooling there are two classes:

(1) Air Cooled.



(b) Casualties in the auto-rifle squads rapidly reduce the power of ammunition supply.

(c) Its fire can be directed on only a limited area at a time, whereas infantry fire can be either concentrated or distributed to suit the wishes of the commander.

(d) The equipment of the auto-rifle squad is very heavy. The Chauchat can be carried on the march only with difficulty.

34. The most important characteristics to be remembered are that the auto-rifle must accompany the infantry platoon, and it must be so organized as to have sufficient mobility; that it is not suitable for overhead fire and must not be used for such; that it is not suitable for indirect fire and that such use should not be attempted.

## CHAPTER II.

### 35. Automatic rifles on the defensive:

*Principles of the defense.*—The underlying principles of the defense is to hold the line securely with the greatest economy of men. It is necessary to bring an effective fire upon all the ground immediately in front of the line across which the enemy can attack. Since machine guns and automatic rifles are able to paralyze the enemy's attack by large losses in a minimum of time, by sudden and overwhelming fire, they are the ideal weapons for covering the ground in front.

Since the beginning of the present war they have been used more and more to replace infantry fire for two reasons:

(a) The ability of the nations engaged to turn out a great number of automatic weapons, since they are all essentially manufacturing countries.

(b) The great destructive power of modern artillery and the great amount of it in use.

Where troops face each other for some time they are enabled by photo-topography to know the exact disposition of each other's forces, and on account of the accuracy of their artillery, practically to obliterate the first lines. To avoid great losses, it is advisable then to hold those front line trenches with auto-rifles and thus have great fire power with a minimum of men.

Thus using small groups with very extended intervals, there is great latitude in the exact location of the groups. This fact in itself gives a great factor of safety, as there are always points in



any line that are relatively much safer than others, and only these will be occupied.

The following diagram illustrates the method of placing auto-rifles in the most protected places and yet covering the entire front with fire.

Suppose A and B are small knolls in a line of defense. The fire trench for riflemen runs as shown by the dotted line X-Y. However, if mutually supporting machine guns or auto-rifles are placed behind each knoll, the whole front is covered by fire. The rifles

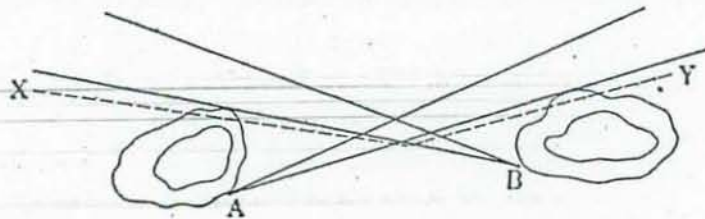

are hidden from the enemy, and have practically an enfilade fire, which is the most effective kind. This is an example of the best method of placing auto-rifles. However, it requires more knowledge of the terrain than frontal fire, as there is danger of leaving defiladed areas where the enemy can safely advance.

### 36. Scope of machine guns and automatic rifles:

Keeping in mind the definition and characteristics of the machine gun and auto-rifle, enables one to reach a correct solution as to the roles of the two. The machine gun with its stable mount and ability to give continuous fire should form the back bone of the main defense. Its fire should be confined largely to indirect and enfilade fire. The auto-rifle should relieve the machine gun of short range direct fire, and should occupy places difficult of access where its mobility comes into play.

### 37. Trench warfare:

Trench warfare involves a double system of trenches, deliberately designed for defense, with the probability of the opposing forces facing each other for a considerable period.

### 38. The front line:

It is generally conceded that either side, if willing to pay the price, can take a front line at any desired point. The front line should therefore not be the main line of resistance, where it can be avoided. The purpose of the front line is, generally speaking:

(a) To observe the enemy and give warning of an attack.



(b) To prevent the enemy from reconnoitering the line of resistance, and to prevent his patrols and raids from entering our line.

(c) In case of a general attack, to check the first move and allow time for the main line and the artillery to be warned; to inflict losses on the attackers, and if some do penetrate the line, to fire upon their rear from points of resistance; to assist the counter-attack of our troops by preventing enemy reinforcements from coming up.

For these purposes of the front line, no other weapon is as useful as the automatic rifle. They interfere much less with the fire of the machine guns than would an infantry line, as the machine guns can be sighted between them. While it may be essential to have a few machine guns in the front line trenches at important points, this use is exceptional. During the day there are very few riflemen in the trench, and the front line can be said to be held by auto-rifles. At night, more riflemen are required in front line trenches.

Auto-rifles should be placed in pairs, with a traverse between them if practicable so they cannot both be destroyed by the same shell. They should be so placed as to give oblique fire. They should be found in all salients.

### 39. Combat groups and strong points:

While the chief function of the auto-rifle is the defense of the first line, this can often be best accomplished by placing them outside the trenches, which are too plainly visible.

The best position for a combat group is an old shell hole connected with a dugout through a tunnel. There is usually a steel observatory, and the auto-rifle is set up only when the alarm is given. Firing should never be done from these holes until the moment of the enemy's assault. Ordinarily no form of cover is used.

These shell holes must be carefully masked, so that their real nature may not be discovered by aerial reconnaissance. The absolute necessity of hiding the firing positions requires the construction of saps and galleries.

To use combat groups most successfully there should be about 150 yards between the front line and the main line, with the combat groups between the two lines. There should be no communicating trench for 50 yards on either side of the combat groups.



In the larger combat groups and strong points, machine guns are usually used in conjunction with auto-rifles.

Strong points on a reverse slope are very effective.

#### 40. The main line:

The basis of the main line is a series of machine gun emplacements. Each machine gun fires obliquely to its front, and the whole forms a continuous belt of fire across the entire front.

If the ground were perfectly level; if there were no obstructions to their fire; and if they could be so placed in this level country that they would not be destroyed by artillery fire, they would constitute a complete defense, but this condition never exists. There will always be dead space over which the machine gun fire will pass harmlessly. This space may be a stream, ravine, sunken road, etc. The number and area of these dead spaces are increased by the fact that machine guns are usually sited low so as to decrease their vulnerability to artillery fire. These are the areas that must be covered by the fire of auto-rifles. They can be fired over the parapet or be pushed forward to places that are inaccessible for machine guns. The top of a flat ridge offers another favorable opportunity for auto-rifles, as machine guns would often be conspicuous and therefore would be destroyed by artillery fire.

*The role of the auto-rifle in the main line then is to supplement the fire of machine guns. They cannot replace them.*

The following sketch shows the location of machine guns and auto-rifles, each covering the ground suited to it and doing the work properly in its sphere:

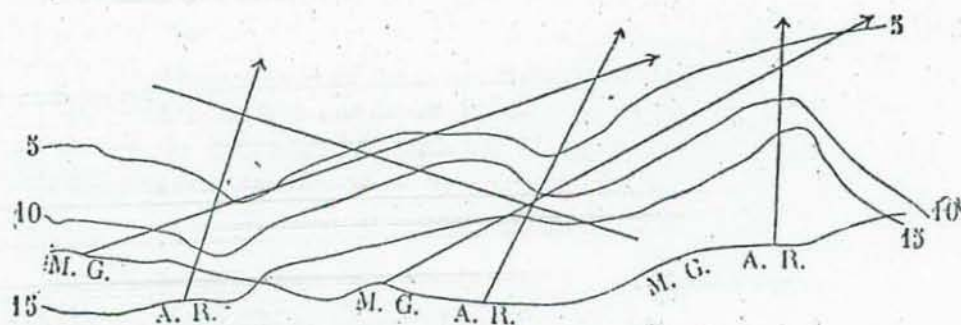

#### 41. Lines of fire:

The auto-rifle in the front line should be allotted definite areas to watch, each rifle firing obliquely to the front. The limits



of the area should be definitely located by objects readily seen by the firer. A range card giving the information should be placed at the position of each rifle.

Only under special circumstances should the gunner be permitted to fire outside his sector. If a neighboring sector is raided and everything is quiet in his own, the rifle may fire in the neighboring sector, but one man must constantly watch the original sector. At the least sign of activity in its own sector, the auto-rifle must transfer its fire to that area.

#### 42. Obstacles:

Wire should be placed so as to hold the enemy under enfilade fire. A careful location of the entanglement will often make it possible to get the enemy where a cross fire can be brought on him by two auto-rifles. The arrangement should not be too obvious or the enemy will avoid the trap. The following diagram shows an arrangement of wire in which each line of wire is enfiladed by one auto-rifle and the intersection of the two lines is brought under a cross fire.

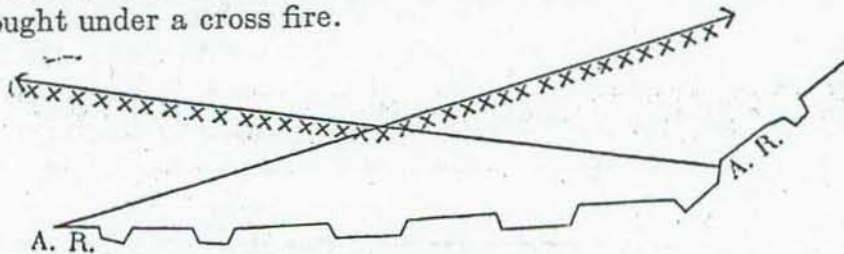

#### 43. Selection of targets:

The auto-rifle should fire only when targets are offered that warrant the expenditure of ammunition or the disclosure of position which is involved in the firing. The sniper is the man to deal with individuals of the enemy. With his special equipment of telescopic sights and periscope he will be much more successful than will the auto-rifleman. This is specially true of the Chauchat, as it has not the accuracy of the Springfield rifle. If the auto-rifle is in a position which exposes it to attack by grenadiers, ordinary riflemen or grenadiers should protect it.

#### 44. Emplacements:

Elaborate emplacements must not be used, as they render the auto-rifles conspicuous. The auto-rifle can be fired from any trench suitable for rifle firing, but definite firing places must be assigned. These places may be loopholed, but, in the more



recently constructed lines, the usual firing place is a depression running obliquely across the parapet. This type gives the correct line of fire, is less visible from the front, and gives to the firer a certain amount of protection. If the auto-rifles are placed close to a high traverse considerable protection from shrapnel is obtained.

Each auto-rifle should have several firing positions, as this materially lessens the chance of detection. Firing places in the main line of resistance that are intended for use at the moment of the enemy's assault should never be used at any other times, as they are likely to be discovered by the enemy and destroyed before the actual assault.

#### 45. Shelters:

Auto-rifles should be kept under cover in the day time or during a bombardment. There will almost always be warning enough to get the auto-rifle into position, as it can be handled about as readily as an ordinary rifle. One member of the auto-rifle team in observation near the firing place will be sufficient. The remainder of the team can remain in their dugouts. At night, it will be necessary to have more men at hand.

#### 46. Ammunition:

Recesses for auto-rifle ammunition should be distributed all along the trench, so there will be no considerable length of trench without its ammunition supply. The recesses should not contain more than 20 magazines, so that the loss from a single shell would not be great. The exact location of these stores of ammunition should be known to every auto-rifleman, and certain men should be assigned to keeping the magazines and ammunition in perfect condition.

#### 47. Patrols:

While auto-rifles will seldom be of use with patrols in trench warfare, they can render great assistance to the patrols if pushed forward from the first line to shell holes where they can protect the flanks of the patrol and cover its retreat if it becomes necessary.

#### 48. In the main line of resistance:

A clear field of fire at short ranges is far more important than at long ranges. The auto-rifle has not the stability which gives great accuracy at long range as has the machine gun. Its endurance is such that if it is brought into action while the enemy is at



long range, it will probably be out of action in the critical stages of the assault.

**49. With outposts:**

Auto-rifles can be of great value in covering roads, bridges, stream crossings, and covering avenues of approach generally. They should be assigned to the line of resistance and to the larger bodies on the line of observation as pickets.

50. The use of auto-rifles in the consolidation of captured ground is dealt with under the attack.

### CHAPTER III.

**51. Automatic rifles in the attack, trench warfare:**

*Trench to trench attack.*—The use of the auto-rifle in trench to trench attack should be considered under four heads:

- (1) The preparation.
- (2) The assault.
- (3) The reduction of strong points and centers of resistance.
- (4) The consolidation of the ground and the exploitation of the success.

52. The preparation usually extends over a considerable period of time and provides for a multiplicity of details that hitherto have been considered not only impracticable but impossible. Trench warfare has become so complex that a satisfactory solution of any situation is possible only where all contingencies have been thought of and provided for in advance.

(a) *The reconnaissance.*—Plans cannot be made until certain information as to the enemy's dispositions is available. A great part of this information is provided by aerial reconnaissance in the form of photographs. They report the positions of trenches, guns, etc., as well as the billets of the troops in rear of the line and the probable avenues of approach if it should become necessary for them to reinforce.

The infantry reconnaissance consists largely in patrols and raids. The purpose of these is:

- (1) To discover the strength of the front line and any arrangements for assault, openings made in the wire, etc.
- (2) To capture prisoners from whom the enemy's intentions may be learned.
- (3) To destroy materiel.
- (4) To determine the exact line of the enemy's barrage.



In both patrols and raids the chief function of the auto-rifle is to protect the flanks of the raiding party. At the beginning, it will seldom be possible for them to be useful in any other way. After the patrol or raid has accomplished its purpose or if it has been driven back and is returning to its own lines, the auto-rifles are of great value in covering its return. Whatever the outcome of the raid, the raiding party probably will be fired upon by machine guns before it is safely within its own lines. Auto-rifles pushed well to the front and flanks can do much to neutralize and render ineffective the fire of these guns.

(b) Provision for the supply of magazines and ammunition during the assault must be made, and carrying parties from the dumps forward must be provided for. The load of the auto-rifleman is normally near the maximum limit, and he cannot be further loaded down if he is to do his part in the fight. Neither can the ammunition he carries be expected to last him during the assault and the consolidation.

(c) *The rehearsal.*—A replica of the trenches to be attacked is staked out and the troops to make the assault are practiced over this course. The positions to be occupied by the auto-rifles in the consolidation can be roughly assigned. In this way, the load that each team will have to carry can be determined. Squads going only a short distance can carry more ammunition. With squads assigned to the flanks this is especially important, as upon their holding their ground often depends the success or failure of the assault. Units going to the farthest objective should carry less ammunition, as they should be able to keep up with the artillery barrage, and at the finish should be fresh enough to quickly consolidate the captured ground. Extra ammunition for them will have to be provided for by extra carriers.

(d) *Keeping open the gaps in the wire.*—For days before the assault, the artillery barrage attempts to destroy the wire entanglements and all obstacles. Once gaps are made in the wire, it becomes the duty of the auto-rifles to keep them open. This will be especially difficult at night, as every effort will be made by the enemy to repair these gaps.

53. *The assault* has its time regulated by the artillery and machine gun barrage. If the assault is to succeed, it must follow so closely behind the barrage that there will be no opportunity for the enemy to get up out of his dugouts and man his trenches and machine gun emplacements.



The place for auto-rifles of the Chauchat type, using marching fire, is usually in the front wave of the first line.

In order that the enemy may have no definite information as to the moment of beginning the assault, part of the auto-rifles should continue firing from the jumping off trench until the marching fire has begun. It will seldom be profitable to mass more than 8 auto-rifles for this fire, as a greater number becomes a conspicuous target for the artillery.

Marching fire has advantages and disadvantages, but the advantages seem to outweigh the disadvantages. The advantages are:

(1) That it needs very little preliminary arrangement. The gunners using marching fire simply go forward with the first wave.

(2) If the gunner is not hit and keeps up, the fire is continued throughout the assault, and on arriving at the enemy's trench the auto-rifle can be fired into it.

(3) If any of the enemy try to escape, the gunner can pursue them with fire while he actually pursues them on foot.

The disadvantages are:

(1) That the fire of the auto-rifle is much less accurate and therefore has less effect. Any trained gunner firing from the bipod on the ground ought to be able to get effect on personnel at once, at close range; firing from the hip, his aim is much less accurate and the effect is more moral than material.

(2) When strong opposition is encountered and the assaulting troops have many casualties, the conspicuous gunners will be the first to fall. Thus in the event of an initial failure, when all the rifles have been placed in the first line, no auto-rifles will be so placed that they can cover the reorganization, or the withdrawal of the unsuccessful troops, as is the case when they occupy concealed positions in the front. The gunners are most likely to fall in some zone of fire where it would be very difficult for other members of the team to detach their auto-rifles and slings from them. Every auto-rifle gunner should be taught when advancing on the flanks to watch half right or left, to guard against flank attacks from machine guns, as they will prove very disastrous to our troops if neglected, because in the advance every one's attention is centered on the immediate objective in front.

An auto-rifle is best suited to repel such an attack, as it can change front instantly, while it would take some time and cause no small loss to wheel enough riflemen to the flank to repel such an attack.



#### 54. Combat Groups, strong points, and supporting points:

The above names are applied to the "islands" of resistance of a defensive position, according to the strength of the body of troops occupying them. Those held by a platoon or less are called "Combat Groups." Those made up of more than one "Combat Group" and held by more than one platoon and not exceeding a company are called "Strong Points." Those centers of resistance made up of several "Combat Groups" and "Strong Points" and held by more than one company are known as "Supporting Points."

In every case the general line of action involved in their reduction is the same, the platoon sends out squads, the company sends platoons, and the battalion sends companies to get around the enemy's flank and cut off his retreat and reinforcements.

The usual small combat group used by the Germans is the machine gun emplacement, armed with a single gun and situated to gain surprise flank fire. These combat groups are sited in the most unexpected places and are so skillfully concealed that they are impossible to locate from the ground or from the air. It is therefore essential that the officer commanding be constantly on the lookout for such surprises, and that he act quickly and decisively when the crisis comes.

A valuable point to note about the heavy sledge on which the German machine gun is most often mounted is that it permits of a traverse of only 30 degrees. This means that it can traverse only half the width of the range at which it is firing; i. e., if it opens fire at a body of troops at 300 yards range, a force sent off to outflank it will be perfectly safe if it starts its enveloping movement 150 yards to a flank, and will probably be safe at 100 yards to a flank.

Thus a German machine gun, on a sledge mounting, which had opened fire on a line of men, would have to have its mounting moved to enable it to fire at the outflanking party, and this would permit of the advance of the party at which it first fired.

Even if the machine guns were mounted on some mount the same principle holds good, for a machine gunner cannot watch several sides at once. Moreover, a machine gun with an all-round traverse must be less under cover than one firing from a loop hole. It cannot have a covered emplacement, nor be defladed from any direction, so all flanking parties have a good chance of silencing it. If the ground allows it, the simultaneous attack from both flanks, while the gun is kept occupied to the front, is to be recommended.

The role of the auto-rifle in such an attack is either to open



fire at once at the machine gun while other sections work around, or it can be sent around with one of the flanking parties.

The first is the natural course when an enemy machine gun opens fire unexpectedly or when a platoon finds itself in an unfavorable position, for in such cases it is important for the auto-rifle to get into action at once to cover the movement of the remainder. It is generally found that the auto-rifle monopolizes the attention of the machine gun, and the remainder of the platoon can maneuver with little loss; also, if the machine gun is firing through a loop hole, the auto-rifle can put it out of action only from the direction in which it is firing.

The second method, to send the auto-rifle around a flank, is often advisable when the position of the strong point has been ascertained before the advancing platoon comes under fire. It is particularly to be recommended when the strong point takes the form of a trench line which can be enfiladed. The enemy is sure to be disconcerted when heavy fire is brought upon him from an unexpected quarter, and the auto-rifle can often be sited in a position from which it can cut off his retreat.

In all attacks on combat groups, the covering fire of auto-rifles is of the utmost importance, as usually no artillery is present, and it is necessary to supplant artillery fire effect as much as possible by the fire effect of small arms.

Covering fire may be gained in two ways:

- (1) By pushing the auto-rifle well ahead of the line of concealed positions, or from commanding positions in the rear.
- (2) By using marching fire.

#### 55. Reduction of strong points and supporting points:

The most difficult part of the assault is the reduction of centers of resistance formed by machine guns, auto-rifles, and grenadiers in shell holes. These centers may come in the way of a surprise or may not, depending on whether or not the aerial photographs have revealed them. If they have been revealed, detailed preparation is made beforehand. If they come as a surprise, the battalion commander must act promptly, as the attack will be absolutely held up until the center of resistance is destroyed.

The troops detailed to attack a strong point would ordinarily be rifle grenadiers, machine guns, hand bombers, riflemen, and auto-rifles.

The French have worked out the attack of strong points in great detail. Their scheme is given below, not as a normal method



but as an illustration of how a strong point might be reduced, under certain circumstances. The method to be used in any particular case must be fitted to the particular circumstances of that case.

The troops detailed for this particular operation are 32 rifle grenadiers, a machine gun company, 24 automatic rifles, and a platoon of riflemen and hand bombers.

The attack consists of 3 distinct phases:

- (1) Fire preparation.
- (2) Advancing with marching fire.
- (3) The cleaning up of the trenches.

*First Phase.—Fire Preparation.*—(a) Systematic fire of the machine guns and auto-rifles and riflemen to cover the rifle grenadiers while they are getting into position and carrying on the bombardment.

(b) Systematic bombardment of the center of resistance by rifle grenades.

The rifle grenadiers should be distributed in groups of 4 to 8, in an enveloping formation, so as to be able to bring converging fire. A couple of Stokes mortars would add greatly to the strength of this bombardment (see sketch).

*Second Phase.—The Assault.*—When the bombardment has reached its greatest intensity, the assault is made by the auto-rifles, firing while marching. There must be no interval between the fire of the grenades in the bombardment and the marching fire, as the most important thing is to leave the enemy in his dugout in ignorance concerning the beginning of the assault.

The machine guns should be so placed as to fire as long as possible (see sketch).

*Third Phase.—The Cleaning Up of the Trenches.*—Under cover of the marching fire, the platoon of bombers advance in groups of squads. As soon as the trenches have been reached, the bombers begin cleaning up systematically. The bombers work in the trenches and the 6 auto-rifles on the surface. If the communicating trenches have sectors of much length, the auto-rifles may do great execution. They may also prove of great value in covering trench crossings and preventing the reinforcement of the enemy's bombers or resupplying of grenades.

As soon as the cleaning up has reached a satisfactory stage, the advance of the battalion continues.



REDUCTION OF A STRONG POINT. — First phase : Fire preparation.

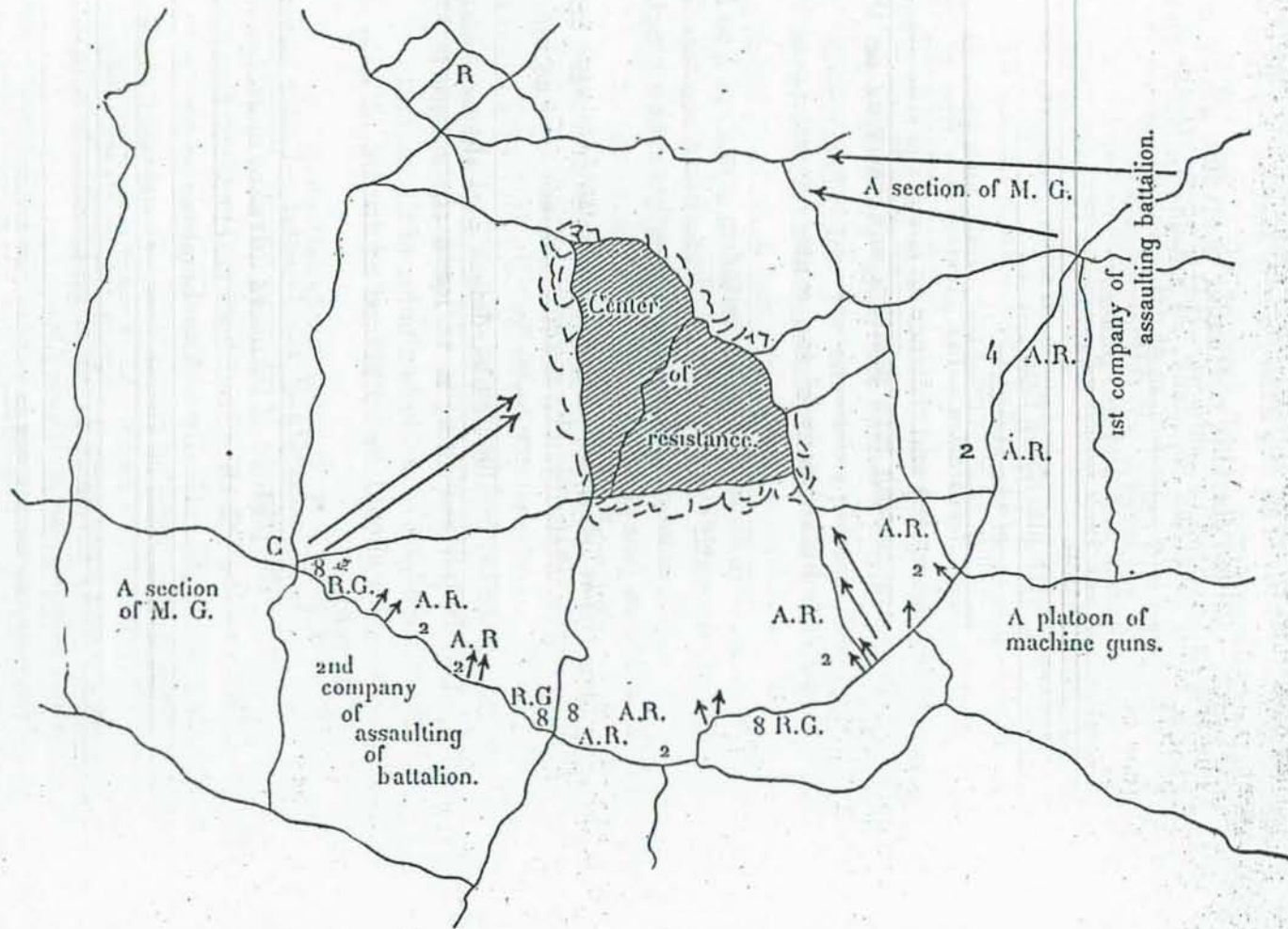



REDUCTION OF A STRONG POINT — Second phase : The marching fire. Advance of the platoon of grenadiers.

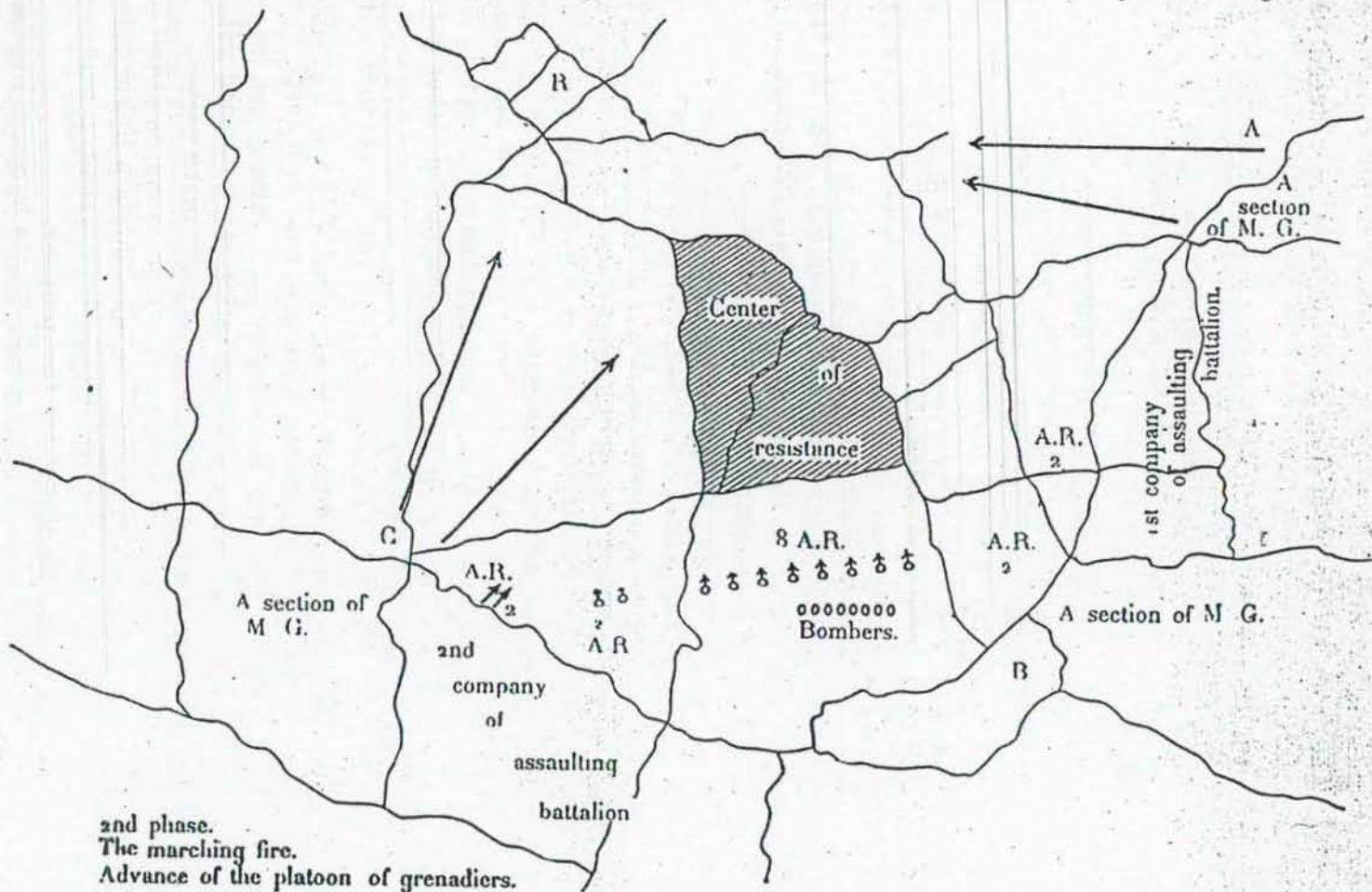



For the successful attack of a center of resistance the following details must be arranged:

- (1) The front of the attacking company must be reduced in order to facilitate operations.
- (2) Distribution of the rifle grenadiers and auto-rifles.
- (3) Assignment of selected men for the marching fire.
- (4) Place and formation of the platoon of riflemen and hand bombers.
- (5) Sectors of fire assigned the machine guns.

Only the most careful and detailed preparation will make the assault a success.

#### 56. Woods:

Woods of small and medium sizes are especially likely positions in which to find strong points located, and there is really only one good way of attacking such a point.

If the wood has been subjected to artillery fire, the task is made more difficult, as the fallen trees merely give more cover to the enemy and make passage almost impossible.

Most organized woods are cut by belts of fire that cross each other at right angles and divide the woods into sectors.

In attacking such a place, the first move should be to flank it and enfilade the belts of fire; in this way the enemy's communication can be greatly interfered with and his movements from one sector to another, either to reinforce or retreat, may be stopped.

After the woods have once been entered, no aid from the artillery can be expected, as it is impossible for observers either on the ground or in the air to tell the positions of either our own troops or those of the enemy.

After the wood has been taken, it should be vacated and the line consolidated in front, as enemy artillery is sure to have the exact range and will commence shelling as soon as it receives word that its own troops have been driven out. Also if our line is in front of the woods, where communication can be gained with the aeroplanes, the task of our artillery is made much easier.

In the case of a very large wood, which cannot be taken in one operation, it becomes necessary to consolidate a line within the wood itself. Some prominent line such as a road, a belt of fire, or a ridge should be chosen for this purpose.

The rear side of each cleared belt should be made impassable by making obstacles of barbed wire, boughs, etc., so that if the enemy tries to rush across, he will be caught and held under the fire of a machine gun or auto-rifle. All passage by our own troops



from front to rear should be along fixed trails, as the gunners are required to fire at anyone who tries to cross at any point other than those trails.

A good method of making these trails easy to follow in the dark, is to stretch a wire along the side about waist high, so that a man can follow the wire with his hands.

The front of each belt of fire should be well camouflaged, so that the enemy will be unable to locate them.

#### 57. Villages:

The method of attack used in woods is equally applicable to villages, using the streets in the same way that the belts of fire were used in the woods. The auto-rifle is especially valuable in such a place, as it can fire from windows, towers, roofs, walls, etc., where it would be impossible to get enough riflemen to gain an equal volume of fire. The village is taken, block by block, as the wood is taken sector by sector.

As in the case of woods, and for the same reason, the village should be left as soon as taken, and a line established in front of it.

58. Neutralizing the fire of machine guns that have survived the barrage is one of the most important duties of the auto-rifle in the assault. No matter how thorough the preparation is, there will always be a few isolated machine guns that have lived through it, and they must be given prompt attention and their fire rendered ineffective.

59. If gaps in the assaulting line have to be filled, the quickest and most effective method of doing it is to order up auto-rifles from a reserve company.

60. After the assault, the auto-rifle really comes into its own. It becomes temporarily the most important arm of the assaulting troops. It is the time that requires the greatest daring and initiative on the part of the auto-rifle squads. No delay nor hesitation is permissible. For this reason, assignments should be made prior to the assault for the following duties:

- (a) Consolidation of the ground won.
- (b) Establishment of outposts.
- (c) Sending out of contact patrols.

#### 61. Consolidation of the ground:

The general position on which the troops are to consolidate is usually selected before the assault. When this position is reached, the auto-rifles must take immediate measures for holding the



ground. Experience has shown that it is impossible for the machine guns to keep up with the assaulting troops. The auto-rifle must establish belts of fire all along the front until this duty can be taken over by the machine guns. This enables the machine guns to make proper reconnaissance, so they will not go into positions which later will prove to be untenable. With the auto-rifle, the important consideration is to get into some position at once, from which an effective fire can be delivered. If it later develops that the position is unsuitable, the auto-riflemen can easily move.

The line of consolidation should not be the enemy's old line, as this position will be accurately located on the maps, and artillery fire can be brought to bear on it with much less delay. This line should preferably be established a short distance beyond the enemy's line. The flanks of units should be well covered by auto-rifles until the positions of neighboring units are determined.

The first few minutes after the new line is reached are among the most critical of the whole assault, as it is at this time that the enemy will make his counter attack. It is at this time that the auto-rifle has its greatest usefulness.

#### 62. Outposts:

As soon as the consolidation begins, outposts are established. These usually consist of about a squad of riflemen, with an auto-rifle. Such groups should be pushed out about every 150 or 200 yards along the front. They take cover in shell holes, altering them only as much as is absolutely necessary for protection. It is important not to attempt to link them up and make a continuous trench at this time, as it gives information to the enemy as to the position. This will be found out later, but a few minutes delay at this stage may be of extreme importance.

#### 63. Contact patrols:

The battalions must not be content with the capture of the assigned objective. It is possible that the enemy has been so demoralized that he has abandoned further ground or can be driven from it with practically no resistance. If he is given time to recover, he may reoccupy this ground, and make the operation of taking it very expensive. Contact patrols must be sent out at once, to determine the exact status of the ground in front and to take possession of any unoccupied ground. The French call these



patrols "Antennae" and have prescribed a normal operation for them.

Each company sends out one or two contact patrols, which are constituted as follows:

One Bombing squad.

Two auto-rifle squads.

One rifle grenadier squad.

The whole to be commanded by a platoon leader.

Rifle squads may follow as a support if desired.

#### 64. The formation of the patrol:

The terrain is cut up, and usually the communicating trenches obliterated, but the shell holes afford cover. The patrol must attempt to advance without being seen especially it must never offer a favorable target to the enemy.

The hand bombers form a line with extended intervals. The platoon leader follows at about 20 paces, and is in turn followed by the rifle grenadiers at about 10 paces. The auto-rifles are distributed on each flank. The rifle squad follows in rear as a support.

#### 65. The advance of the patrol:

*The bombers* advance, one man at a time, by rushing from one shell hole to another. They keep in touch with the squad in rear by signals, and attack in order to push the reconnaissance.

*The rifle grenadiers* establish a semicircular barrage extending from 80 to 150 yards to the front, to clear possible cover.

*The auto-rifles*, two on each flank, have one of these two directly supporting the hand bombers by sweeping the open places, and the other covering the flank. The auto-rifles, which cover the flanks, co-operate with the neighboring patrols and prevent the enemy from counter attacking through the intervals between patrols.

#### 66. Overcoming resistance:

Two kinds of obstacles to the advance are encountered, hostile grenadier groups or nests, and machine guns established in shell holes.

As soon as a nest of hand bombers is encountered, it is attacked by our hand bombers. The hand bombers establish a smoke barrage, by means of grenades, to cover their movements. The rifle grenadiers establish a barrage in rear of the nest to isolate the



group and prevent reinforcements. The auto-rifles protect the front and flank of the hand bombers.

If machine guns are encountered, the automatic rifles open fire and attempt to drive the machine gunner to cover. Covered by this fire, the rifle grenadiers close in to within range and open a systematic bombardment. As soon as the machine gun has been rendered ineffective, the grenadiers advance. In this attack, it is desirable to separate the rifle grenadiers into two groups so that they can bring a converging fire.

67. The British attack a machine gun in a slightly different manner. They open fire with Lewis rifles to cover the advance of the rifle grenadiers. When within range, the rifle grenadiers open fire on the machine gun with incendiary and smoke grenades. Under cover of the smoke, the bayonet men go forward and attempt to gain the flank of the machine gun, when they rush it and put it out of action.

#### 68. Organization of the terrain:

When the contact patrol has reached the assigned objective, a position is taken up in shell holes. The grenadiers occupy the advanced points, while the auto-rifles take up a flanking position, slightly to the rear. This marks the line which must be quickly consolidated for the counter attack. It will be necessary to reinforce these patrols by riflemen.

### CHAPTER IV.

#### 69. Automatic rifles in open warfare:

The tactical use of all weapons, being determined by their innate characteristics, powers, and limitations, the general principles of the use of automatic rifles in open warfare remain the same as in trench warfare, the only necessity being to adapt these general principles to the changed conditions which are presented.

The automatic rifle has been developed on the western front during the present war, where trench warfare has so far been the rule. It has not as yet proved its value in open warfare.

Generally speaking, its value results from its greater mobility, as compared to the heavier machine gun, and its greater volume and flexibility of controlled fire, as compared to the ordinary rifle. It being an intermediate weapon between the ordinary rifle and the machine gun, having some of the characteristics of each, it



partakes of some of the functions of each. For example: In cases where machine gun fire would be desirable, and either the machine guns are not available or are not sufficiently mobile for the particular situation; in cases where not a sufficient number of riflemen are available or there is not sufficient room in which to deploy the number necessary to give the requisite volume of fire.

It is a special weapon and its correct uses are confined to special circumstances—the reliable, all around weapon of the infantryman being the rifle and bayonet.

It is particularly adapted to defensive use, where ample supply of ammunition is easy and where the rifle and ammunition for it does not have to be carried continuously nor for great distances.

It is particularly adapted to outpost work where the main object is to hold the line with as few men as possible, giving troops in rear time to prepare for action.

### ATTACK.

In the attack, when the zone of effective hostile machine gun fire is reached, the automatic rifles should usually be in rear of the front line, ready to move to the flank or to support any threatened portion of the front line.

In the advance during the infantry fire fight, up to the assaulting position, the automatic rifles assist in covering the advance from the flanks or by overhead fire from commanding positions in rear. This does not mean that the automatic rifle should be used for *indirect* fire, nor for overhead fire except from high ground in rear.

In the assault, the automatic rifles may be used for marching fire in the first wave or may cover the advance from the flanks or from commanding positions in rear as above.

After the assault, in case the pursuit is not immediately taken up, the automatic rifles are pushed forward to hold the captured position against a counter attack and utilized in outposting the position.

In case of a retirement being ordered, the automatic rifles assist in covering the retirement, using enfilade flanking fire whenever possible.

#### 70. Defense:

In open warfare, as in trench warfare, the defense will normally be intrenched, the only differences being that the intrenchments will be less elaborate, there will be fewer lines of trenches in the



direction of depth, and, instead of one continuous line from Switzerland to the sea, the defensive positions will have flanks. The defensive uses of automatic rifles, as stated for trench warfare, are equally applicable to open warfare.

In the selection of positions for automatic rifles, it should be borne in mind that, except at very favorable targets, the automatic rifle should never be used at ranges greater than 600 yards. (Owing to the inaccuracy of the Chauchat at the longer ranges, it should not be used beyond 400 yards).

The positions selected should be so located as to enable the automatic rifle:

- (1) To defend flanks.
- (2) To defend intervals between trenches.
- (3) To enfilade ground depressions.
- (4) To cover defiles.
- (5) To compensate by volume for short field of fire.
- (6) To occupy locations that do not admit of deployment of sufficient riflemen to develop the necessary volume of fire.



# PART IV MECHANISM

## CHAPTER I.

### DESCRIPTION AND NOMENCLATURE OF THE RIFLE.

#### 71. Characteristics:

The automatic rifle, 1915 Model, is an automatic rifle utilizing the force of recoil. It is classed among the rifles of this category in which the barrel recoils the full length of the stroke.

It fires the French regulation cartridge 86 D (with modified priming). The feeding is done by magazines containing twenty cartridges. This rifle can be fired semi-automatically (single shots) or automatically (continuous fire).

#### 72. Description and nomenclature:

The rifle is divided into two principal parts:

- (A) A non-recoiling part.
- (B) A movable part.

#### 73. (A) Non-recoiling part:

The non-recoiling part includes:

- (1) The housing.
- (2) The receiver.
- (3) The firing mechanism.
- (4) The fittings.

#### 74. The Housing:

Is made out of steel tube. It is used to protect the barrel and to guide its movements. It is formed of two tubes, fixed together by the front assembling collar, and carries as its fore part the flash screen, screwed and riveted on, and the front sight, which by its truncated shape decreases the internal diameter of the housing, constituting a recoil intensifier.

The housing is drilled in front with eighteen holes, allowing the circulation of the air around the radiator.

On the right the ejection opening; below the feed piece opening, in which the feed piece is fixed to the bolt slides. The groove is hollowed out at its rear end to allow the mounting and dismounting of the feed piece; at its forward end, to allow the movement of the cartridge guide.

The back part of the housing ends in the rear assembling collar, in which is screwed the plug carrying the recoil springs.

The plug includes: The plug itself; the threading and the spring guide tube.



The front and rear assembling collars carry, respectively, an assembling clasp and a perforated stud, allowing the securing of the housing on the receiver by means of the assembling bolts.

The front assembling collar has internally a recoil shoulder against which the barrel sleeve bushing strikes when the parts are at the firing position.

On the middle part of the housing the rear sight is fixed.

#### 75. The receiver:

The receiver is formed of two side plates joined by blocks and fastened at the back to the stock.

On the right side plate are to be seen:

The axis holes of the sling swivel, of the front assembling bolt, of the cartridge guide rod guide; the holes for the passing of the screws of the handle block; the axis holes of the trigger, of the safety lock, of the sear lever, of the rear sling swivel and of the rear assembling bolt.

The right side plate possesses a hollowed out part for the sliding motion of the operating handle.

On the left side plate are to be seen:

The same axis holes as on the right plate and the holes of the fixing screws of the barrel catch block and of the cartridge guide rod guide.

Holding together the two side plates, there are:

The *bipod block*, whose forward part is either threaded or tapped for the screwing on of the bipod head. It holds also the front assembling bolt.

The *barrel catch block*, which carries:

(a) The barrel catch, whose nose, lodging itself in a circular notch of the barrel sleeve, holds the latter at its firing position. This lever includes: The nose, the body and the toe; a spring, resting on one side on the block (immovable point) and on the other side on the toe (movable point), forces the nose upwards.

(b) The magazine stop spring, to force off the magazine when the catch is released.

(c) The cartridge guide, pivoting around two trunnions lodged in the side plates, secures the correct introduction of the cartridge in the barrel. This guide includes a ramp, on which the point of the bullet slides, pushed in the direction of the barrel by the feed piece. The guide which, while the rifle is working, has an up and down motion, is operated by the cartridge guide rod through a roller.

The barrel catch block is fixed to the side plates by two screws which also fasten the cartridge guide rod guide to the right side plate.



The *handle block*, at the center part of which are to be seen:

(a) The handle, fixed to the block by a rod and nut.

(b) The magazine catch, operated by its handle, forced forward by its spring (immovable pointblock; movable point-catch). The handle block is fixed to the side plates by two screws.

The stock, which has a steel plate sunk in the wood, and the recess of the plug catch.

#### 76. Firing mechanism:

The firing mechanism of the 1915 model automatic rifle, is fitted on a receiver, formed by two side plates and a bottom plate. On the side plates, there are: The axis holes of the trigger, of the safety lock, and of the sear lever.

On the bottom plate there are: The trigger bar spring stud and the hollowed out part for the passage of the trigger tail and of the bar bow.

The receiver is ended at its lower part by the pistol grip, covered with wooden plates fixed by two bolts.

Fixing together the bottom plate and the grip, is the trigger guard.

Between the two side plates, we have:

(a) The *trigger bar spring* (immovable point—the stud; movable point—the bar).

This spring draws the bar and the trigger forward.

(b) The *trigger bar*, on which are: The eyehole, the rounded part, the body, the inclined plane, the toe.

(c) The *trigger*, with its axle bearing and its tail. The trigger is fixed with the trigger bar by the trigger bar pin.

(d) The *sear*, with its axle bearing, its head and the supports of the sear spring. The sear is fixed to the trigger by a bushing.

(e) The *sear spring* (immovable point—bottom plate; movable point—support surface of the sear) forces the head of the sear upward.

(f) The *sear lever*, on which are to be seen: The fore part (axle bearing shaped), the hole for the sear lever bushing, the tail. On the fore part of the lever is fixed the hand sear by means of the hand sear pin.

(g) The *hand sear*, which includes: The head and its rounded part, the lower arm.

(h) The *hand sear spring* (immovable point—sear lever; movable point—hand sear lower arm) forces the hand sear lower arm forward.

(i) The *safety lock*, passes across the side plates perpendicularly and includes: The arm with its knob and its stop, the lock with the lifter.



**77. The fittings:**

The fittings include:

- (a) The *bipod*, composed of a head and two legs ended by points. The legs are fixed to the head by means of screws.  
 (b) The *sling swivels*, including the swivel rings and the bolts for fastening.

**78. (B) Movable part:**

The movable part includes:

- (1) The barrel, the breech casing and the barrel recoil spring.  
 (2) The bolt and the bolt recoil spring.  
 (3) The feeding mechanism.

**79. Barrel, breech casing and barrel recoil spring:**

(a) *Barrel*.—42 centimeters long. At its front end the threading, allowing the fixing of the barrel nut on which the gas acts to intensify the recoil.

The barrel is covered at its fore part and on three-quarters of its length by an aluminum radiator. This radiator is kept in place on one end, by the barrel nut; on the other side, by a sleeve screwed on the barrel and the barrel sleeve bushing. This sleeve has a circular notch, in which sticks the nose of the barrel catch.

The barrel is extended at its back part by the breech casing screwed on it.

(b) *Breech casing*.—The breech casing contains and guides the bolt mechanism.

There is to be seen, on the right, the ejection opening, at the back part of which is the inclined plane for the bolt head stop.

At the lower part, the guiding groove, ended at its back part by the slope which acts on the hand sear when the barrel is at its firing position, and the flat surface.

Inside the breech casing and at its fore part are locking lock shoulders, against which the rear surface of the bolt head locking lugs bears, when the bolt is locked.

The recoil spring bushing fits into the rear end of the breech casing.

(c) The *barrel recoil spring* (immovable point—plug; movable point—bushing), is a spiral spring surrounding a tube fixed on the plug. (Energy compressed, 26 to 20 lbs.)

**80. Bolt and the bolt recoil spring:**

The bolt is composed of the bolt head and the bolt body.

(a) *The bolt head*.—To be seen:

| At its fore part, the hollow face in which protrudes the ejector with its spring; the locking lugs; the bed of the extractor with its

spring  
of the  
In  
bolt  
slide  
and  
Ph  
right  
T  
the  
"lug  
A  
bolt  
T  
(mov  
thread  
acts t  
point  
fixed  
8  
sleeve  
T  
ridge  
catch  
casing  
feed  
hand  
C  
shar  
at the  
ing  
D  
back part  
at its  
g lock  
locking  
S  
breech  
auto  
of  
movable  
tioned on  
chan  
bolt  
by  
bar  
wh  
ejector  
with its



spring. At its back part, the working lugs, the notch for the point of the bolt head stop.

Internally, the seat of the firing pin.

(b) *The bolt body*.—On which are fixed the firing pin and the bolt stem. To be seen, the working helicoidal grooves, in which slide the working lugs of the bolt head; the bed of the feed piece and of its stud.

Placed in the side of the cocking bolt, and protruding on the right side, is the bolt head stop.

This stop is ended at its lower part by a point which drops into the movable bolt head notch, when the head is in the position "lugs vertical."

At the forepart of the bolt body, is the passage for the movable bolt head working lugs.

The stem of the bolt body possesses at its rear part a collar (movable support of the bolt recoil spring).

(c) *The bolt recoil spring*.—(Immovable point—plug; movable point—bolt stem collar). It is a spiral spring lodged in the tube fixed on the plug.

### 81. The feeding mechanism:

The feeding mechanism includes, the feed piece and the cartridge guide rod.

(a) *The feed piece*.—Including the arm; the guide ribs of the feed piece on the breech casing; the sear notch and the operating handle.

(b) *The cartridge guide rod*.—On which are to be seen the S shaped groove of the roller and the hole for the stem of the operating handle, which holds the latter and the feed piece together.

NOTE.—The feeding mechanism is completed by the magazine.

## CHAPTER II.

### OPERATION OF THE RIFLE.

#### 82. Barrel and bolt motions:

*Generalities*.—In any automatic rifle, it is necessary to secure automatically, at a given time, the separation of the barrel and of the bolt, in order to allow the execution of the different operations (extraction, ejection, introduction of a new cartridge in the chamber) indispensable to the working of the gun.

In the automatic rifle, 1915 model, the movable whole (barrel, bolt) is sent backward by the recoil energy, after which the barrel is brought back to its firing position by its recoil spring, while the bolt, held backwards, cannot come back to its first



position until the barrel is at its forward position. The separation of the barrel and of the bolt is then completed.

### 83. Working:

To fire, one must cock the bolt mechanism, then hook the magazine under the rifle, placing the fore extremity between the bipod block and the radiator housing, and the back extremity on the magazine catch.

In the barrel and bolt motion of the automatic rifle, 1915 model, three phases must be considered:

*First phase:* Recoil of the barrel and the bolt (the two pieces joined).

*Second phase:* Return of the barrel to its firing position.

*Third phase:* Return of the bolt forward.

### 84. First phase:

*Recoil of the barrel and bolt* (the two pieces joined).

*Motive power:* The explosion.

*One operation:* Cocking.

The first shot occurs, the gas acting on the bolt sends it backwards. As the bolt is bolted to the barrel, this is sent backwards too. The recoil springs are compressed. The movable breech (and accordingly the firing pin) being at its extreme backward position, the breech recoil spring (acting in this case as main spring) being compressed, the cocking is effected.

*Maintenance of the cocking.*—The maintenance of the cocking is secured by the hooking of the breech hook on the sear head.

### 85. Second phase:

*Return of the barrel to its firing position.*

*Motive power:* Barrel recoil spring.

*Four operations:*

(1) Withdrawal of the firing pin.

(2) Unlocking.

(3) Extraction.

(4) Ejection.

As soon as the action of the recoil disappears, the barrel recoil spring sends the barrel forward.

The barrel going forward, forces the bolt head, to which it is locked, to accompany it.

### 86. Withdrawal of the firing pin:

The bolt body being held at its backward position by the hooking of the feed piece on the sear head, only the bolt head can go forward.



The progress of the bolt head (8 mm. long), the length of the rectilinear part of the working helicoidal grooves, causes the withdrawal of the firing pin from the hollow face.

The unlocking is not yet finished, since the working lugs move in the rectilinear part of the helicoidal grooves.

#### 87. Unlocking:

In consequence of the tension caused on the bolt head by the barrel, whose recoil spring is only incompletely relaxed, working lugs passing in the helicoidal parts of the bolt body, leave their bed against the locking shoulders of the breech casing, hence unlocking.

#### 88. Extraction:

The barrel going on with its run, quits the bolt head. The cartridge case which was in the barrel being, on the other hand, detained by the extractor claw, is pulled out of the chamber, hence extraction.

#### 89. Ejection:

When the distance between the bolt head and the interior edge of the ejection opening is sufficient, the cartridge case, pushed by the ejector, pivots around the extractor and is projected to the right, passing through the ejection opening, hence ejection.

#### 90. Third phase:

*Return of the bolt forward.*

*Motive power:* Bolt recoil spring.

*Three operations:*

- (1) Introduction of a cartridge into the barrel and closing of the chamber.
- (2) Locking.
- (3) Firing.

#### 91. Introduction of a cartridge into the barrel and closing of the chamber:

The barrel being brought back to its firing position, the breech casing, acting on the firing mechanism, sets free the bolt. Through the action of the bolt recoil spring, compressed at the time of the bolt recoil, the latter is sent forward. In this motion, the forward part of the feed piece arm, meeting a cartridge raised up by the magazine, pushes it forward and upward in the direction of the chamber.

The bolt head lower locking lug, acting then on the cartridge, introduces it into the chamber, hence introduction of a cartridge; after which the bolt closes the entrance of the chamber.



**92. Locking:**

At the end of this first operation, the bolt recoil spring is not completely relaxed. In consequence, it forces the bolt body forward.

As the bolt head is stopped by the cartridge, only the bolt body can go forward. The bolt body going forward and being able only to make a rectilinear movement, forces the bolt head to turn, owing to the action of the helicoidal grooves on the working lugs of the bolt head. The locking lugs get in their beds against the locking shoulders of the breech casing, hence locking.

**93. Firing:**

The bolt body, going further forward through the action of the spring, still incompletely relaxed, the working lugs move in the rectilinear part of the grooves, and the firing pin protrudes in the hollow case, hence firing.

## REMARKS.

**94. Action of the recoil intensifier:**

The front sight is built in such a way as to play the part of recoil intensifier. For that purpose, it presents internally a truncated chamber in which the gas expands, when the bullet is shot out of the barrel.

The gas acting backward on the fore part of the barrel nut, increases the recoil action it had already caused on the bolt at the discharge of the first shot.

**95. Action of the barrel catch:**

When the barrel gets to its firing position, a slight recoil movement on the barrel is to be expected on account of the shock of the barrel sleeve bushing against the front assembling collar.

The barrel catch stops this motion. Protruding above the barrel catch block, the nose of the catch, disappearing to allow the barrel's passing, pops up again as soon as the latter is at its firing position, and enters a notch on the barrel sleeve.

Any movement of the barrel is then impossible.

But, as it is necessary that the barrel should be able to recoil, the action of the catch must disappear before the discharge of the shot.

For that purpose, when going forward, the feed piece strikes the body of the catch, forcing the nose down. The barrel is then free.

**96. Action of the bolt head stop:**

The bolt head stop's function is to keep the bolt head in the position "lugs vertical," when the bolt is sent forward, [For that

purpo  
notch  
positi  
impos  
canno  
Bu  
it is  
to all  
The s  
the b  
Fo  
action  
latter  
for w  
in the  
bree  
97  
T  
two p  
(ma  
(pul  
T  
posit  
rel  
bo  
P  
A  
T  
m  
to  
rear  
to th  
hand  
upw  
incl  
J  
stri  
piv  
con  
war  
tr.  
bre  
exer  
in  
t



purpose, the stop has at its lower part a point, which gets into a notch at the rear part of the bolt head, while the latter is in the position "lugs vertical." Any rotation of the bolt head is then impossible, as the stop, striking the inside of the breech casing, cannot rise and disengage the bolt head.

But, when the bolt head is practically in touch with the barrel, it is necessary that the action of the stop should disappear, so as to allow the freeing of the bolt head which has to turn to lock. The stop point must at that instant leave its bed in the notch of the bolt head.

For that purpose, when the bolt head is forced to turn, the action of the notch's inclined edges, on the stop point, raises the latter out of its bed in the bolt head. This raising up is possible, for when the locking occurs, the high part of the stop protrudes in the ejection opening and is no longer striking the inside of the breech casing.

#### 97. Firing mechanism:

The automatic rifle, 1915 model, firing mechanism permits two kinds of firing:

- (1) Automatic firing.
- (2) Semi-automatic or intermittent firing.

The execution of these two kinds of firing is controlled by the position given to the safety lock lifter.

#### 98. Automatic firing:

Position of the lifter—horizontal (safety lock at M).

A shot has been fired:

The barrel and bolt recoil together. The bolt is held to the rear by the sear. As the result of the gunner holding the trigger to the rear, the trigger bar engaging with the lower end of the hand sear forces the upper portion of the hand sear forward and upward. This places the top of the hand sear in the path of the inclined plane of the breech casing.

Just as the barrel reaches the firing position the inclined plane strikes the top of the hand sear forcing it down. As the latter is pivoted to the sear lever, it also forces the sear lever down and consequently the sear. This releases the bolt which goes forward and fires another shot.

As the barrel again recoils the hand sear is released by the breech casing. This allows the sear lever to rise due to the force exerted by the sear spring.

#### 99. Semi-automatic firing:

Position of the lifter—vertical with the eccentric portion



facing down. This brings the lifter in contact with the rear part of the inclined plane on the trigger bar.

Assume that the gun is in a cocked position with the trigger released:

Pulling the trigger draws the trigger bar to the rear. This tends to throw the upper part of the hand sear forward, at the same time raising it. As it cannot rise on account of being in contact with the breech casing, it forces the sear lever and consequently the sear down, which releases the bolt.

While this action is taking place the trigger bar is forced down by its inclined plane riding on the lifter until finally the forked portion at its rear end is forced below the lower arm of the hand sear and the hand sear returns to its normal position out of the path of the breech casing.

Before the bolt can again be released it is necessary to release the trigger so that the fork of the trigger bar can again engage the lower arm of the hand sear.

#### 100. Safe:

Position of lifter—vertical with the eccentric portion turned upward.

Safety lock at S:

In this position the lifter is in contact with the lower part of the sear lever so that the latter cannot be lowered. Therefore, the sear cannot be depressed and the rifle cannot be fired.

#### 101. Feeding mechanism:

The gun being cocked, insert a full magazine.

The first cartridge, held by the ears of the magazine, is in the path of the feed piece.

When the trigger is pulled the feed piece striking the upper portion of the base of the cartridge forces it forward out of the magazine. The point of the bullet strikes the ramp of the cartridge guide and is directed toward the chamber into which the cartridge is finally forced by the bolt head.

The second cartridge is forced up by the magazine spring against the bottom of the feed piece and rises to the feeding position against the ears of the magazine, when the mechanism is recoiled to the rear as the result of the explosion of the first cartridge.

NOTE.—In order to provide a clear path for the feed piece the cartridge guide is lowered by its roller traveling in the groove of the cartridge guide rod as soon as the cartridge guide has performed its function of directing the bullet end of the cartridge towards the chamber.



This part  
 trigger  
 at the  
 ing in  
 d con-  
 down  
 forked  
 hand  
 of the  
 release  
 ge the  
 turned  
 part of  
 before,  
 is in  
 upper  
 of the  
 bridge  
 the car-  
 spring  
 feeding  
 mechanism  
 a first  
 ce the  
 ove of  
 s per-  
 bridge

BARREL AND BREACH SLEEVE

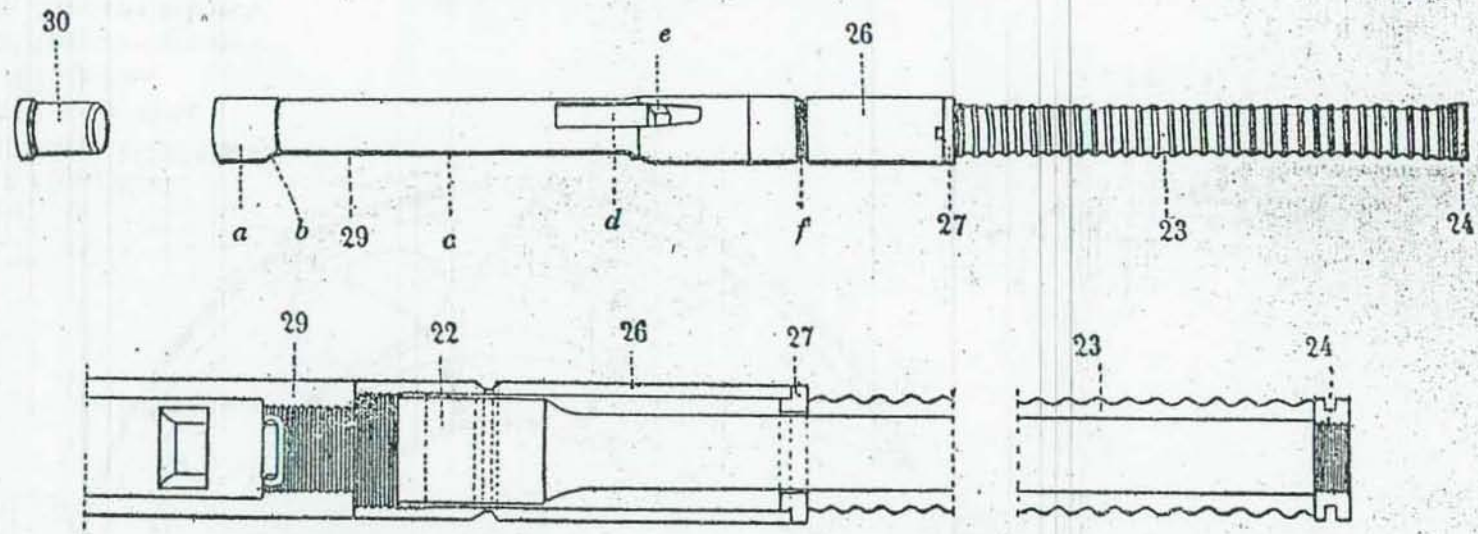

- 30 Recoil spring bushing.
- a Flat.
- b Slope.
- c Guiding groove.
- d Ejection opening.
- e Locking shoulders.

- 26 Barrel sleeve.
- f Circular notch.
- 27 Barrel sleeve bushing.
- 23 Radiator.
- 24 Barrel nut.
- 22 Barrel.

29. Breech sleeve.



ASSEMBLY OF THE FEEDING MECHANISM

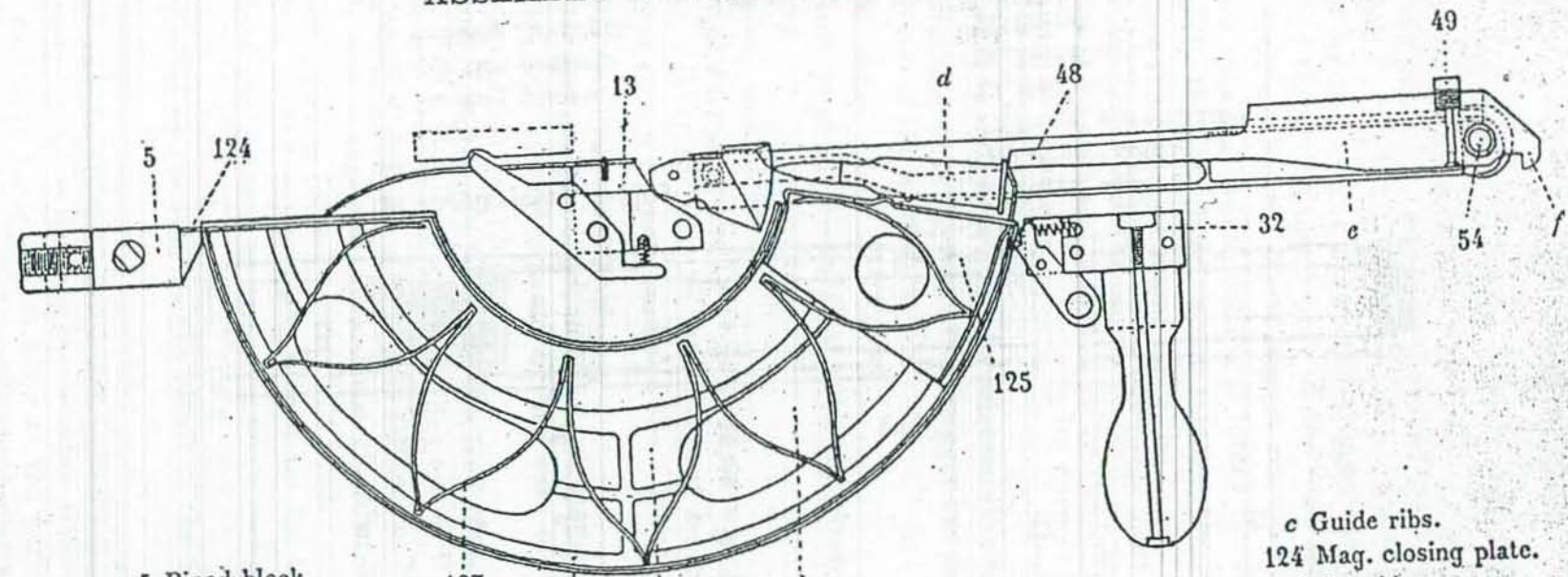

- 5 Bipod block
- 13 Barrel catch block.
- 32 Handle block.
- a Magazine.
- 127 Magazine spring.
- 125 Magazine follower.
- b Hollowed-out part.

- c Guide ribs.
- 124 Mag. closing plate.
- d Cartridge.
- e Feeding mechanism.
- f Feed piece.
- 47 Brech hook.
- 49 Assembling stud.
- 54 Operating handle.



### FEEDING MECHANISM

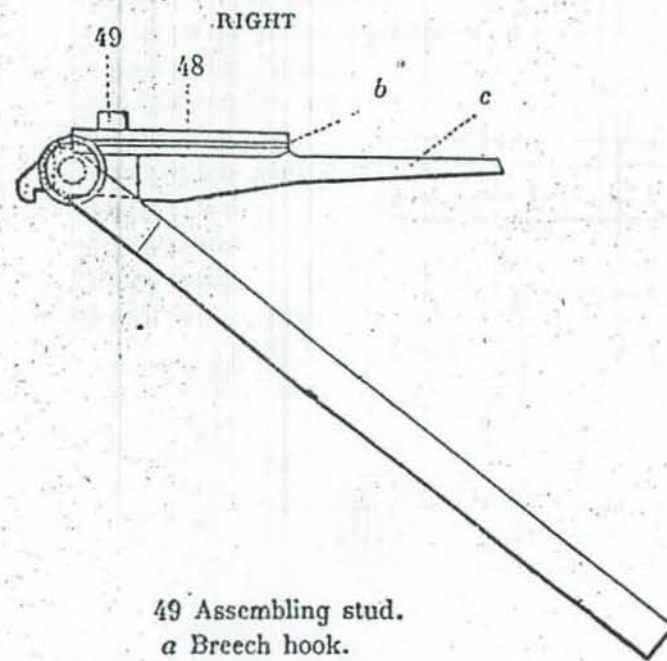

- 49 Assembling stud.
- a Breech hook.
- 21 Cartridge guide rod.
- 48 Feed piece.

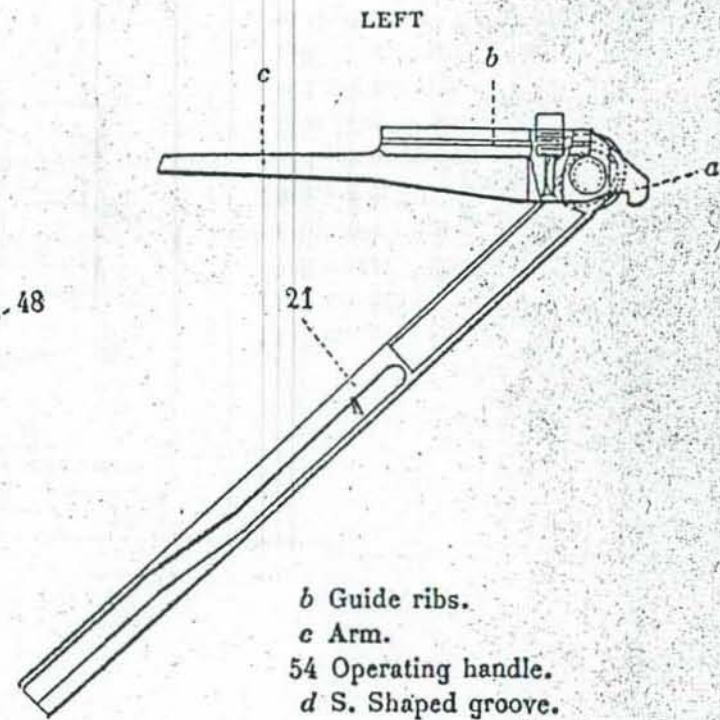
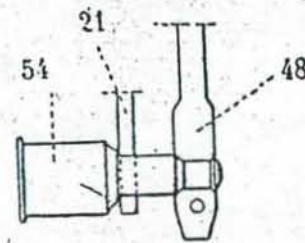

- b Guide ribs.
- c Arm.
- 54 Operating handle.
- d S. Shaped groove.



## BOLT HEAD AND BOLT BODY

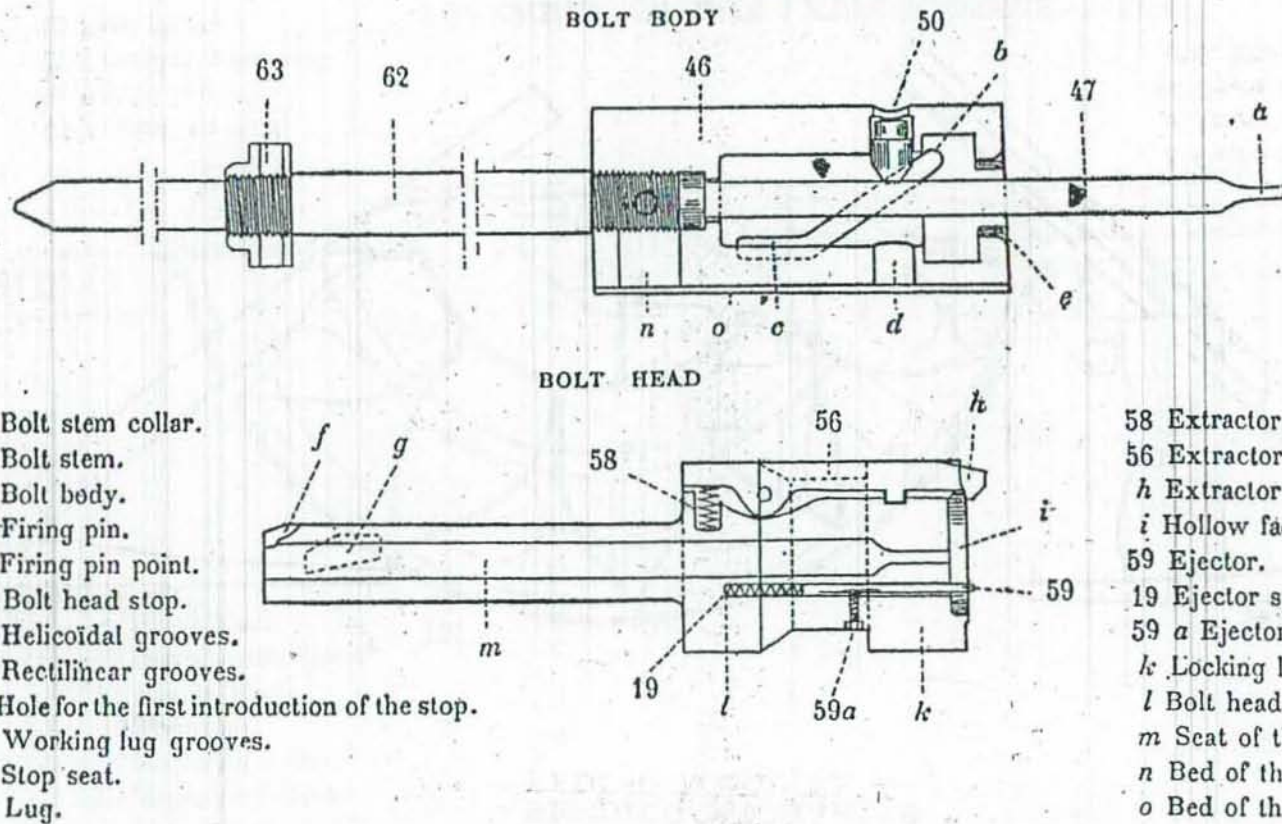

63 Bolt stem collar.

62 Bolt stem.

46 Bolt body.

47 Firing pin.

a Firing pin point.

50 Bolt head stop.

b Helicoidal grooves.

c Rectilinear grooves.

d Hole for the first introduction of the stop.

e Working lug grooves.

f Stop seat.

g Lug.

58 Extractor spring.

56 Extractor.

h Extractor claw.

i Hollow face.

59 Ejector.

19 Ejector spring.

59 a Ejector screw.

k Locking lugs.

l Bolt head reinforcer.

m Seat of the firing pin.

n Bed of the carrier assembling stud.

o Bed of the carrier.



FIRING MECHANISM

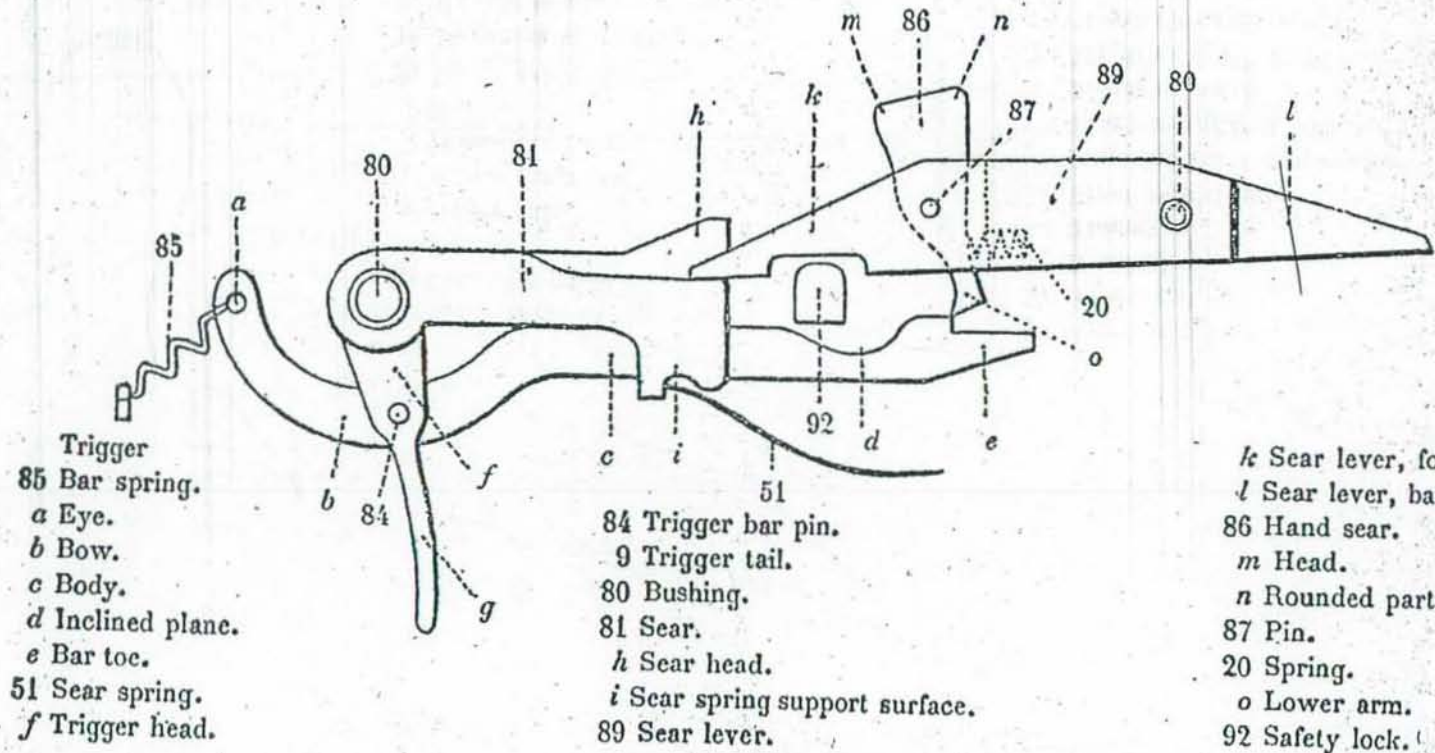

- Trigger
- 85 Bar spring.
- a Eye.
- b Bow.
- c Body.
- d Inclined plane.
- e Bar toe.
- 51 Sear spring.
- f Trigger head.

- 84 Trigger bar pin.
- 9 Trigger tail.
- 80 Bushing.
- 81 Sear.
- h Sear head.
- i Sear spring support surface.
- 89 Sear lever.

- k Sear lever, fore part.
- l Sear lever, back part.
- 86 Hand sear.
- m Head.
- n Rounded part.
- 87 Pin.
- 20 Spring.
- o Lower arm.
- 92 Safety lock.



## BLOCKS

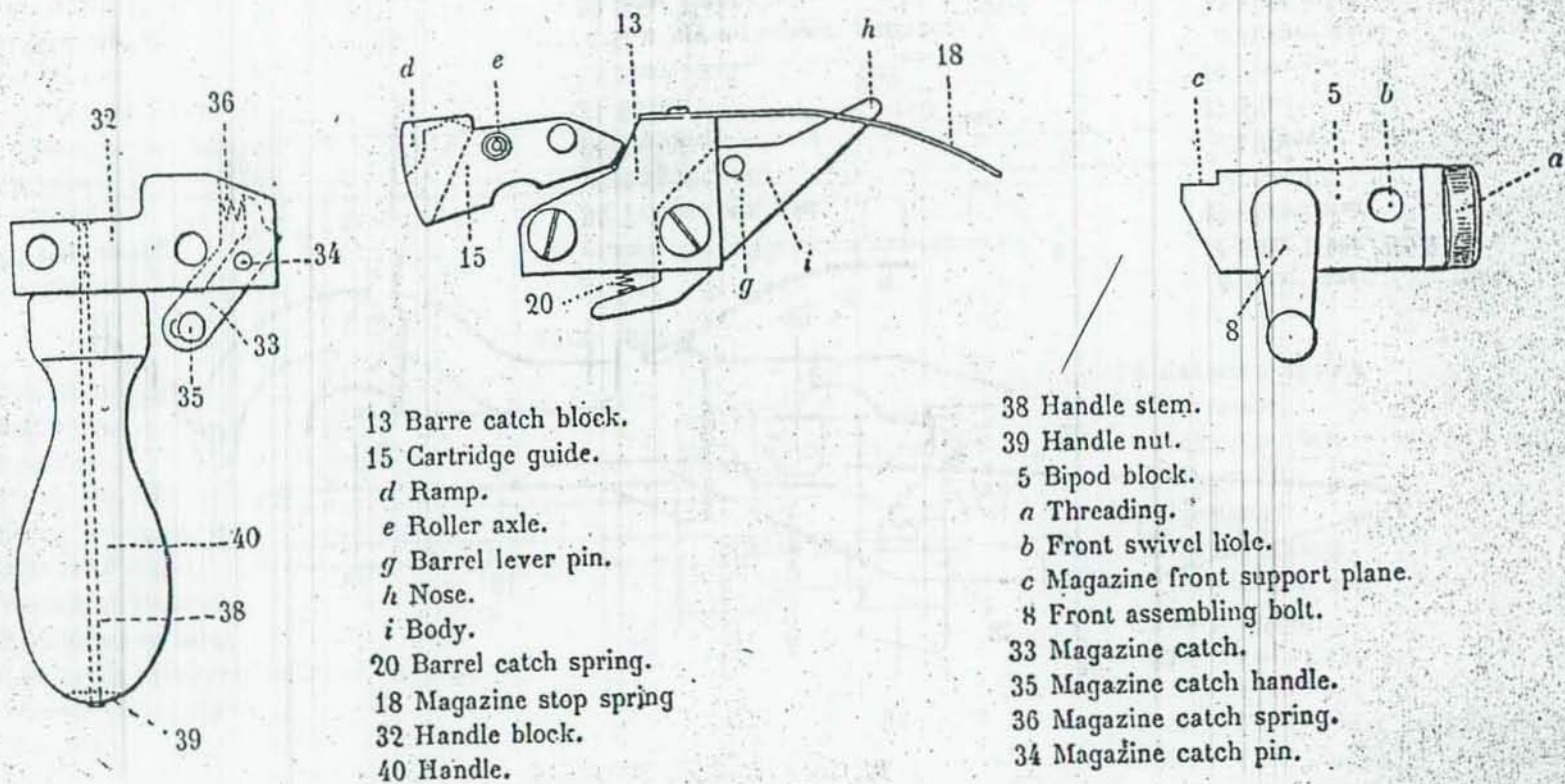

- 13 Barre catch block.
- 15 Cartridge guide.
- d* Ramp.
- e* Roller axle.
- g* Barrel lever pin.
- h* Nose.
- i* Body.
- 20 Barrel catch spring.
- 18 Magazine stop spring
- 32 Handle block.
- 40 Handle.

- 38 Handle stem.
- 39 Handle nut.
- 5 Bipod block.
- a* Threading.
- b* Front swivel hole.
- c* Magazine front support plane.
- 8 Front assembling bolt.
- 33 Magazine catch.
- 35 Magazine catch handle.
- 36 Magazine catch spring.
- 34 Magazine catch pin.



### RECEIVER SIDEPLATES

RIGHT

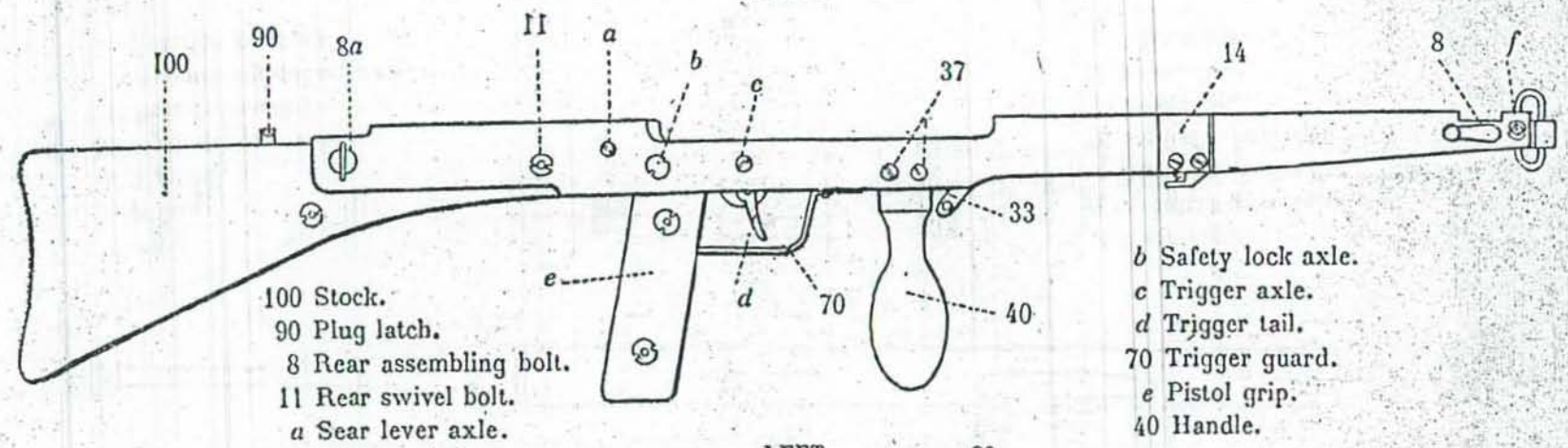

LEFT

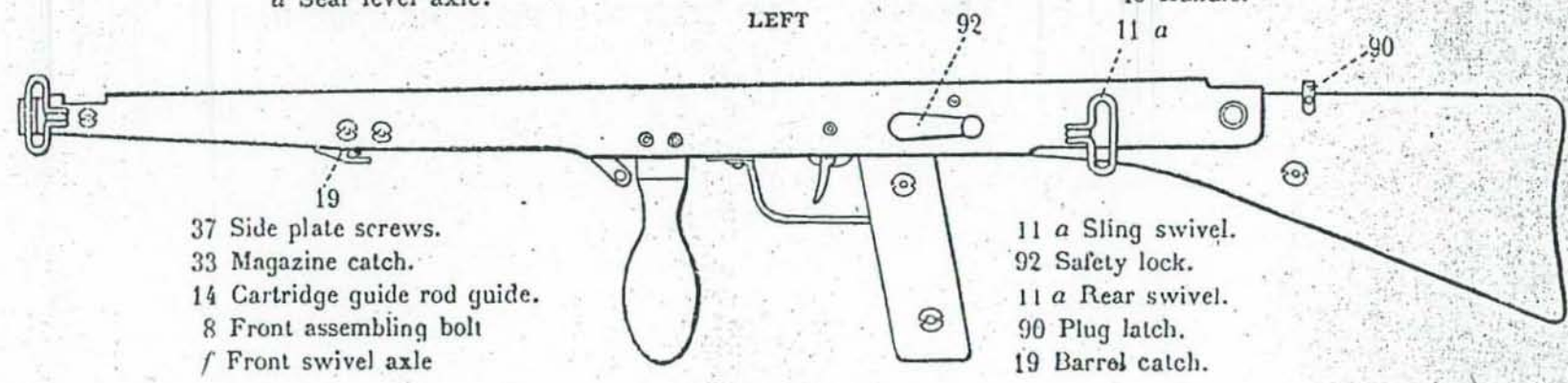



## HOUSING

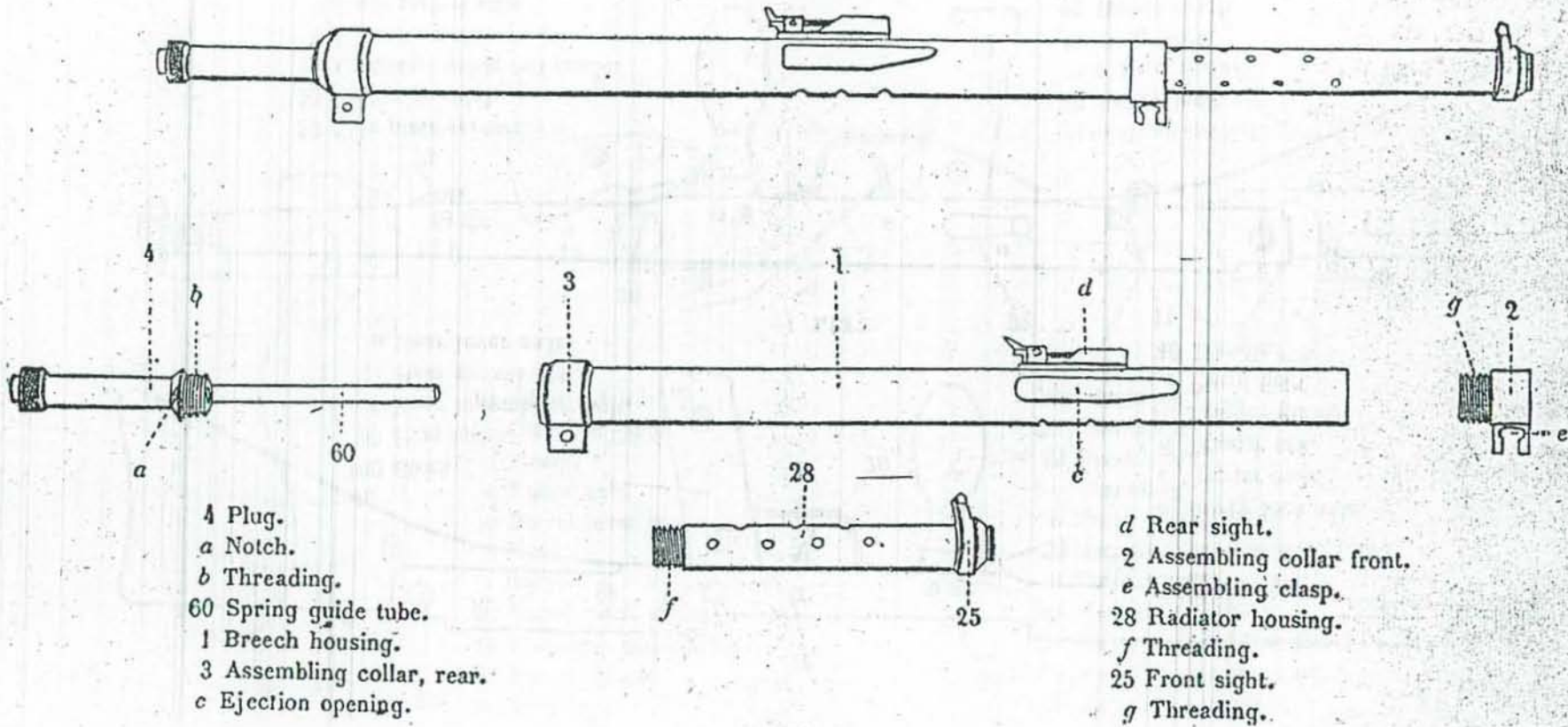

- 4 Plug.  
 a Notch.  
 b Threading.  
 60 Spring guide tube.  
 1 Breech housing.  
 3 Assembling collar, rear.  
 c Ejection opening.

- d Rear sight.  
 2 Assembling collar front.  
 e Assembling clasp.  
 28 Radiator housing.  
 f Threading.  
 25 Front sight.  
 g Threading.



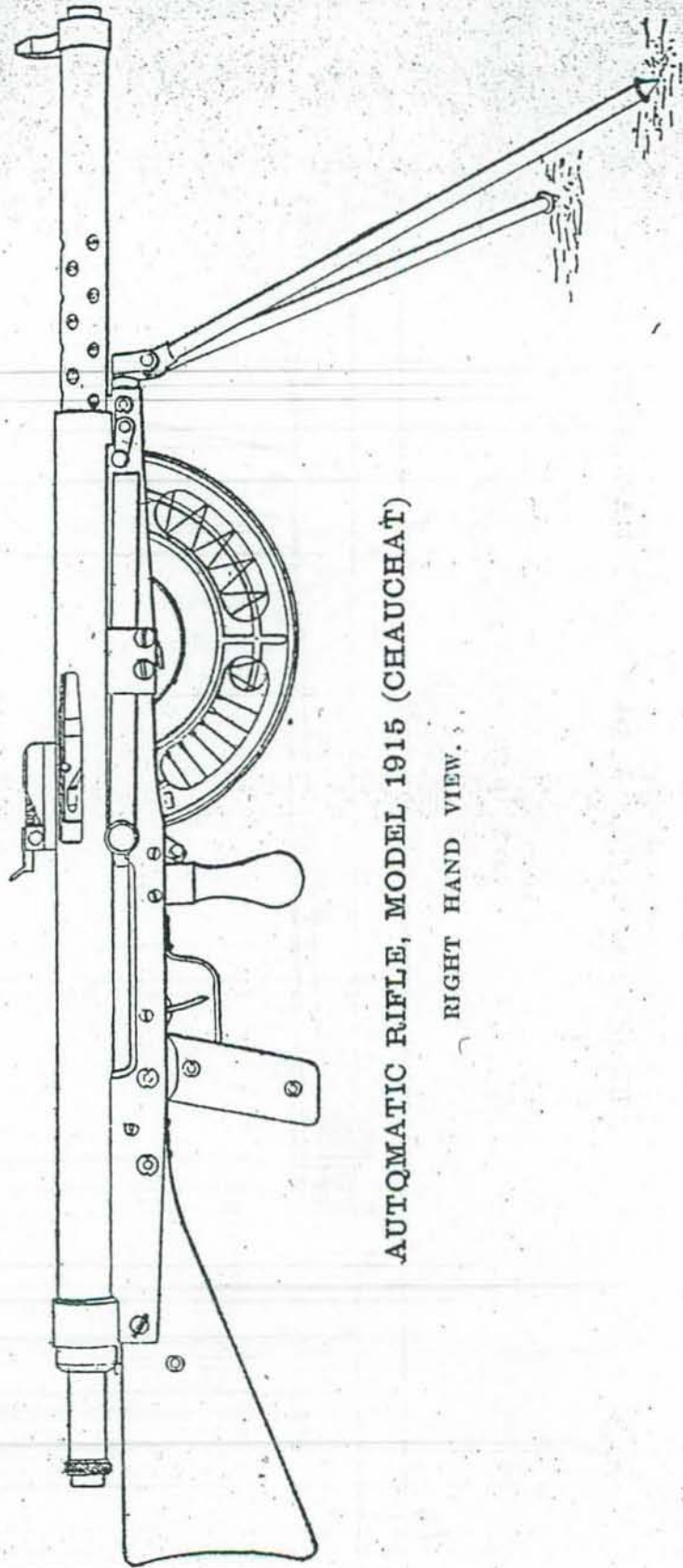

AUTOMATIC RIFLE, MODEL 1915 (CHAUCHAT)

RIGHT HAND VIEW.



AUTOMATIC RIFLE, MODEL 1915 (CHAUCHAT)

LEFT HAND VIEW.

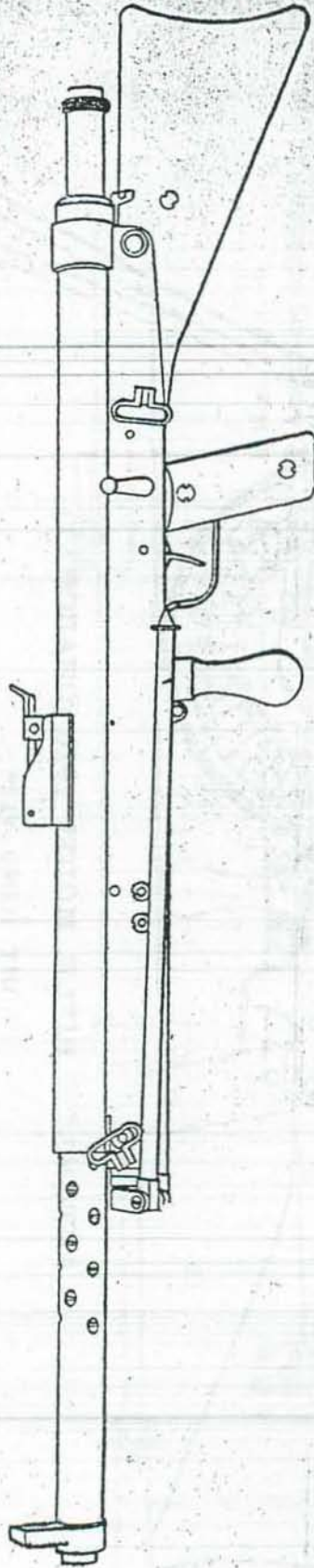



FITTINGS

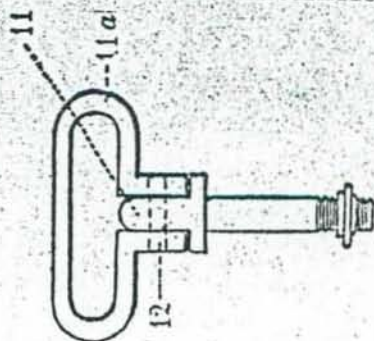

- 11 Sling swivel bolt.
- 11 a Sling swivel bolt.
- 12 Sling swivel pin.
- a Threading.

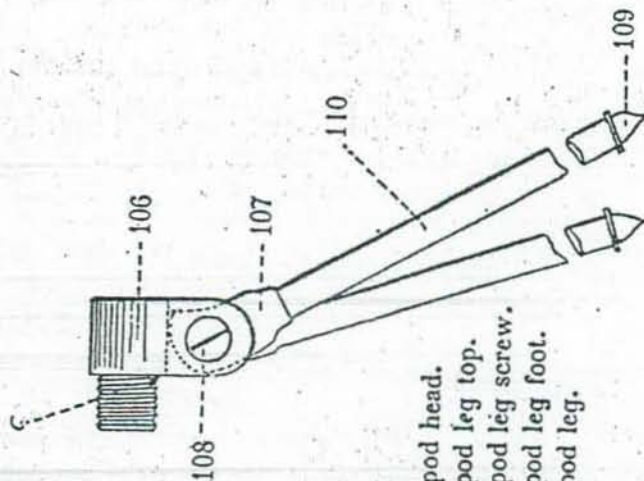
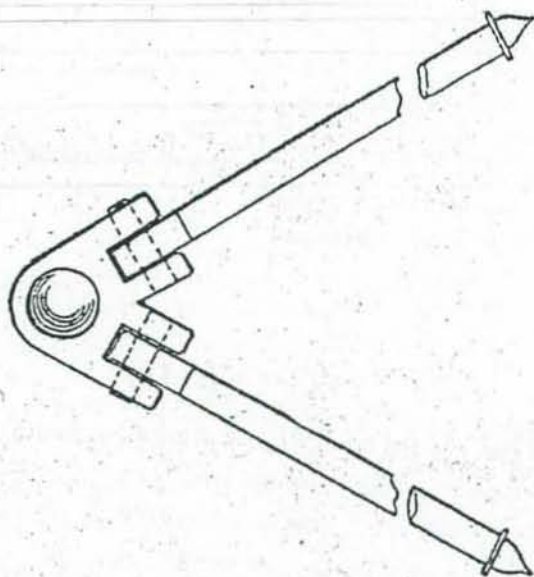

- 106 Bipod head.
- 107 Bipod leg top.
- 108 Bipod leg screw.
- 109 Bipod leg foot.
- 110 Bipod leg.



### SAFETY LOCK POSITION OF THE LIFTER

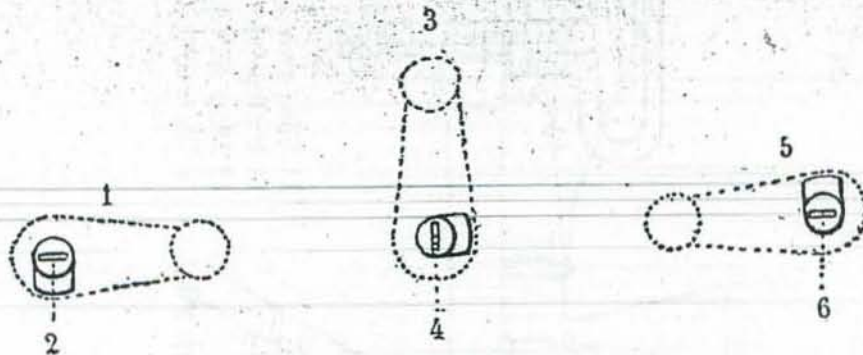

- 1 Round by round firing.
- 2 Lifter vertical and turned downwards
- 3 Automatic firing.
- 4 Lifter horizontal.
- 5 Safety.
- 6 Lifter vertical and turned upwards.

## CHAPTER III.

### 102. Stoppages of the Chauchat automatic rifle:

The word stoppage is used as being more comprehensive than jam, which has been used quite generally in our service to designate not only jams, properly speaking, but also cessations of fire due to any mal-functioning of the rifle, to broken parts or to defective ammunition.

Experience has proved that a strict observance of the correct firing position diminishes considerably the number of stoppages. Automatic firing is obtained by means of fixed and mobile points. The stability must be absolute. The stability ceases to exist when the firer does not hold his weapon firmly. The expansion of the gas and the recoil springs do not bear the same relation, and the result is a stoppage.

Some stoppages which occurred with the first models have been corrected since modifications have been made in certain parts and the steel tempered differently. The following were causes of these stoppages:

- (1) Broken bolt head stop.
- (2) Broken toe of barrel catch.
- (3) Broken ejector.
- (4) Play between the housing and side plates.

103.  
Chauchat

During  
operati  
the ba

During  
the ba  
tion)

During  
the bo

In the

104

(a) Fr

br

(b) In

qu

(c) Ga

ba

ca

Ej

St

the m

and



103. The following are the stoppages which happen with the Chauchat now in service:

*Stoppages.*

- |   |   |  |
|---|---|--|
| During the first phase of the operation of the gun (recoil of the barrel and bolt)..... | } | 1. Failure to engage the sear notch with the sear.   |
|   |   | 2. Exaggerated elevation of the barrel catch.  |
| During the 2nd phase (return of the barrel to its firing position).....                 |   | 3. Non return of the barrel.   |
|   |   | 4. Failure to extract.   |
| During the 3rd phase (return of the bolt forward).....                                  |   | 5. Failure to eject.   |
|   |   | 6. Failure to feed.  |
|   |   | 7. Bad presentation of a cartridge.  |
|   |   | 8. Misfire.  |
|   |   | 9. The safety lock being set for single shots the rifle fires automatically.                                       |
|   |   | 10. The safety lock being set at safe, the rifle fires.  |
| In the firing mechanism.....  |   | 11. Safety lock being set for single shots, the rifle will not fire at all. Fires automatically, functioning well. |
|   |   | 12. The rifle will not fire when safety lock is set either for single shots or automatically.                      |

104. Failure of sear notch to engage sear:

- | <i>Cause:</i>   | <i>Remedy:</i>                         |
|---|--|
| (a) Friction in the barrel and breech casing or fouled gun.     | Work on by mechanic.<br>Clean the gun. |
| (b) Insufficient quantity or poor quality of the powder.        | New ammunition.                        |
| (c) Gas escapes between the barrel nut and the radiator casing. | Change barrel nut—mechanic.            |

*Effects:* Insufficient recoil of the barrel and the bolt.

*Situation:* The sear notch not engaging the head of the sear, the movable whole returns, the empty cartridge case is not ejected and there is a stoppage.



To continue firing, cock the gun.

The friction is very often due to the friction of the cartridge guide against the breech casing. It is due to a bad position of the cartridge guide rod in the cartridge guide rod guide; the roller being still in the curve of the groove of the cartridge guide rod, when the cartridge guide comes in contact with the breech casing, resulting in a strong pressure when the roller has to pass in the elevated part of the groove.

#### 105. Exaggerated elevation of the nose of the barrel catch:

##### *Causes:*

The wearing out or bending of the pin of the barrel catch by striking against the barrel catch block.

##### *Remedy:*

Exchange or straighten the pin.

*Effect:* The barrel catch, under the action of its spring, is elevated too high.

*Situation:* The nose of the catch presses against the radiator, which chips out the aluminum and fouls the breech housing and guide. This may cause a failure of the sear notch to engage with the sear or non-return of the barrel.

#### 106. Non-return of the barrel:

##### *Causes:*

- (a) Difficult extraction.  
Defective cartridge.
- (b) Difficult unbolting.  
Fouling.
- (c) Weakness of barrel recoil spring.
- (d) Friction of the barrel and breech casing in the housing, or against the cartridge guide.  
Fouling.

##### *Remedy:*

Cleaning.

New spring.

Work of mechanic—see the regulating of the cartridge guide rod guide under 1.

Cleaning.

*Effect:* Non-return of the barrel and a stoppage occurs.

*Situation:* In the first two cases the barrel is retained in its rear position by the sear notch engaged with the sear; in the other two cases the barrel does not completely return to its forward position. The cartridge case remains in the barrel. Work the operating handle to cause the barrel to go to its forward position. If that is not sufficient, knock the butt of the gun against the ground, first putting the safety lock at safe.



**107. Failure to extract:***Causes:**Remedy:*

- |  |                   |
|--|-------------------|
| (a) Fouling of the chamber.                        | Cleaning.         |
| (b) Defective ammunition, head of shell too thick. |                   |
| (c) Broken extractor claw.                         | Change extractor. |

*Effect:* The head of the cartridge has not been engaged by the extractor.

*Situation:* The barrel has returned to its firing position with an empty shell in the chamber. To extract that shell use the hand extractor, or rod which is in the cleaning kit.

**108. Failure to eject:***Causes:**Remedy:*

- |                             |                                 |
|-----------------------------|---------------------------------|
| (a) Ejector spring is weak. | New spring.                     |
| (b) Extractor spring weak.  | New spring.                     |
| (c) Extractor claw worn.    | New extractor—work of mechanic. |

*Effect:* The shell instead of being projected through the ejection opening, falls back in the breech casing.

*Situation:* When the bolt goes forward it is stopped by this empty shell.

**109. Failure to feed:***Cause:**Remedy:*

- |                               |  |
|-------------------------------|--|
| (a) Dirty magazine.           | Exchange the magazine without losing time. |
| (b) Weak magazine spring.     |  |
| (c) Magazine plates deformed. |  |

*Effect:* The follower does not rise; the feed piece does not find a cartridge in its path.

*Situation:* Stoppage with bolt closed, no cartridge in the chamber.

**110. Bad presentation of the shell in the direction of the chamber:***Causes:**Remedy:*

- |  |   |
|--|---|
| (a) Defective magazine (ears too wide).            | Change magazine.                        |
| (b) Insufficient elevation of follower.            | Change magazine.                        |
| (c) Insufficient elevation of the cartridge guide. | Regulate the cartridge guide rod guide. |



*Effect:* The cartridge, pushed by the feed piece arm, strikes against the high part of the breech casing in the first case; in the second case, under the sloping part of the cartridge guide; in the third case, between the breech casing and the cartridge guide.

*Situation:* Stoppage. The bolt, which is not completely locked, stopped in the first case by the pushing of the lower part of the bolt head against the body of the cartridge case; in the other cases by the pushing of the feed piece arm against the head of the shell.

111. The safety lock set for single shots, the rifle fires automatically:

*Cause:*

(1) Worn lifter or worn inclined plane of the trigger bar.

*Effect:* The lifter does not push the bar down sufficiently.

(2) Play in the safety lock axle (see par. 113).

*Effect:* The lifter, instead of acting on the bar, is elevated by the bar.

*Situation:* In both cases, the toe of the bar remains in contact with the arm of the hand sear, and therefore prevents the pivoting of the hand sear, whose head comes in contact with the ramp of the breech casing.

*Remedy:* Exchange the worn part.

(Defective ammunition, insufficient quantity or poor quality of powder are able to produce automatic fire when the safety lock is set for single shots. In this case the sear notch does not engage the sear but the feed piece arm may have passed over the head of the cartridge which is in the magazine and pushed it forward when the bolt returns forward. The resistance of the head of the cartridge at this moment is sufficient to produce a separation of the barrel and bolt and to permit, therefore, the ejection of the shell and the introduction of new shell and the discharge.)

112. The safety lock set at safe, the rifle fires:

*Cause:*

*Remedy:*

Too much play in the safety lock axle.      New safety lock.

*Effect:* The lifter, instead of stopping the depression of the sear lever, is itself pushed down by this lever.

*Situation:* The sear lever, not being blocked, pushes on the sear and disengages the sear notch.



113. The safety lock set for single shots, the rifle does not fire. Set for automatic fire, fires well:

*Cause:*

Inclined plane of trigger bar too thick.

*Remedy:*

File the inclined plane of the bar or the lifter slightly.

*Effect:* Premature lowering of the trigger bar.

*Situation:* In firing single shots, the toe of the bar does not maintain contact long enough with the arm of the hand sear, and therefore does not act on the mechanism. In the automatic firing, the inclined plane not acting at all, the gun functions well.

114. The rifle will fire neither by single shots nor automatically:

*Cause:*

Play in the axle of the trigger, of the sear and of the sear lever in their tubes.

*Remedy:*

Exchange the worn parts.

*Effect:* The two fixed points of the firing mechanism are out of place.

*Situation:* The axle head of the sear and the body of the sear lever receive in part the pressure which should be at the point or contact of lever and sear. For this reason the sear head is not lowered sufficiently to allow the freeing of the sear notch.

115. Breaking of parts:

The following are the causes of broken parts:

- (a) Excessive gas pressure.
- (b) Premature firing.

The break always occurs at the weak part of the piece and is often due to defects in the steel.

116. Excessive gas pressure:

- (1) Broken recoil spring bushing.
- (2) Broken operating handle.
- (3) Broken feed piece.
- (4) Broken assembling stud.

The barrel and breech casing are projected backward too violently. The operating handle strikes the rear part of the opening in the side plate. This shock which is increased by the weight of the cartridge guide rod is the cause of the broken parts given above.



The breaking of the bushing is due to its striking the handle of the plug.

It is necessary in case of a broken operating handle to be very careful in handling the weapon, as the following cases may be presented:

(a) When the bolt goes forward, the cartridge guide rod is freed from the axle of the operating handle, but its forward end is always engaged in the cartridge guide rod guide, consequently the cartridge guide is held in an elevated position and the introduction of a cartridge is possible.

The feed piece arm moving forward presses on the cartridge which is in the magazine; the lower lug of the bolt head pushes the cartridge, but the introduction has not been completed, because the mechanism of the bolt has been stopped by the feed piece arm encountering the cartridge guide in an elevated position.

There is a jam, and half of the cartridge is visible. If in any way the cartridge guide rod is freed from the guide, the least shock permits the bolt to go forward, under the action of the barrel recoil spring, forcing the cartridge guide to lower. The arm thus plays the role of the cartridge guide rod.

The bolt mechanism, being connected with the feeding mechanism, the bolting is produced and the cartridge fired.

(b) The operating handle may not be completely broken by the shock mentioned above and may still follow the feed piece and cartridge guide rod when the bolt, under the action of the bolt recoil spring, goes forward. During that movement, a cartridge under the pressure of the feed piece arm is pushed in the direction of the chamber.

If at this moment it is still in contact with the cartridge guide, the operating handle, after its last strain, is then broken, the cartridge guide rod is immobilized. The part of the axle, which remains on the feed piece, jams the feed piece against the cartridge guide rod; the bolt is stopped; the introduction of the cartridge into the chamber is not completed, and the cartridge is visible through the ejection opening. Under these conditions a very slight shock will cause the bolt to go forward and a shot will be fired.

#### 117. Premature firing (Defective ammunition):

- (1) Broken breech casing.
- (2) Broken extractor.

If the primer projects beyond the cartridge head, the discharge takes place at the moment of the introduction of the cartridge



by the shock of the force of the bolt head. The head of the extractor is frequently broken, and the breech casing, after expanding, is broken.

Note: This breaking of the breech casing might happen on account of play of the locking lugs between the locking grooves and the locking shoulders. The locking shoulders sustain a great blow at the moment of discharge, and repeated shocks cause the break which takes place between the forward end of the ejection opening and the groove in front of the right locking shoulder. In this case, replace the bolt head or the same trouble will occur again.

#### 118. Care of the Chauchat and of the magazine:

The stoppages due to the rifle itself are few. The weapon can not be blamed if the ammunition is defective, if the rifle is not cared for, or the gunner is inexperienced. Weapons are of value only when in the hands of well instructed and disciplined men. Experienced gun crews are unanimous in the praise of the service given by this weapon. The troops that have reported unfavorably upon the weapon are those whose gun crews were without sufficient training and discipline at the time of combat.

### CHAPTER IV.

#### DISMOUNTING AND ASSEMBLING OF THE RIFLE.

##### 119. To strip the Chauchat automatic rifle:

- (1) Unscrew plug; remove recoil springs and bushing.
- (2) Take weight off bipod and turn front assembling bolt down; disengage rear assembling bolt from stud.
- (3) Remove the housing from the receiver.
- (4) Remove feed piece.
- (5) Withdraw bolt and remove bolt head from the bolt body.
- (6) Withdraw the barrel and breech casing from the housing.

##### 120. To assemble the Chauchat automatic rifle:

- (1) Insert barrel and breech casing in the housing.
- (2) Assemble the complete bolt and insert in the breech casing.
- (3) Place feed piece on bolt body.
- (4) Push rear assembling bolt to the right.
- (5) Place housing on the receiver.
- (6) Draw cartridge guide rod to the rear.
- (7) Seat front assembling clasp and turn up front assembling bolt.



(8) Elevate cartridge guide; insert cartridge guide rod in its guide and push the rod forward.

(9) Seat the rear assembling stud and secure rear assembling bolt.

(10) Place recoil springs and bushing on the spring tube; screw in the plug.

NOTE.—Never dismount the pieces composing the receiver or fixed on it (blocks, trigger mechanism). These pieces, difficult to get together, are fixed to the brackets by screw bolts so that a repeated unscrewing would wear them out and their loss would so be facilitated.

The cleaning does not necessitate the dismounting of these pieces.

## CHAPTER V.

### CARE OF THE RIFLE AND OF THE MAGAZINE.

#### 121. Rifle:

The rifle must be kept in the best state of preservation. After each firing it must be cleaned and oiled, using for that purpose good lubricating oil, if possible, sperm oil.

The use of kerosene helps considerably in the cleaning of the very fouled parts, but it is necessary to wipe carefully after using it and before greasing, otherwise all the parts put in kerosene would easily oxidize.

In the automatic rifle, 1915 model, the part that gets dirty, generally, is the barrel nut, especially after a long firing. It will be necessary thoroughly to clean this part of the rifle.

The rifle being dismounted, wipe all the pieces thoroughly with a dry rag. Sponge the housing carefully, taking care to clean perfectly the interior of the front sight. Pass the rag inside of barrel and oil abundantly.

Be sure of the cleanliness of the breech casing, especially at its fore part and at the rear edge of the barrel; the support shoulders of the bolt head lugs must be in a perfect state of preservation. Use a soft wooden scraper.

The cleaning of the barrel nut must be done in the following manner: soak the nut in kerosene, scrape lightly, taking care not to whiten the metal.

It must be remembered that any dismounting of the blocks and of the fitting system is forbidden. For cleaning, use the rag and the scraper.



In case of attack by gas, oil entirely and abundantly with sperm oil. It gives a six hours preservation.

#### 122. Magazines:

(a) The magazine is part of the feeding mechanism. Consequently, it must be kept in a perfect state of preservation. After each firing, the magazines must be completely and properly oiled.

(b) The gunners must take care of the state of the spring of each magazine.

To be good, the spring must, when it is taken out of the magazine, have the shape of an incompletely closed crown.

The interruption between the two ends of the spring must not exceed four fingers.

In case of greater spacing, increase the spring's strength by opening with the hand, the angles having the vertex on the internal circumference of the crown.

If in spite of this operation, the spring remains weak, it must be replaced.

#### 123. Outfit:

The outfit of the automatic rifle, 1915 model, is placed in a small cleaning kit which is carried inside the musette.

The outfit carried in this kit is:

- One three pieced cleaning rod.
- One barrel brush.
- One patch section.
- One housing and breech casing sponge.
- One defective cartridge extractor.
- One hand extractor.
- One oil can.
- One kerosene can.

### CHAPTER VI.

#### 124. Cartridges:

The automatic rifle, 1915 model, uses the cartridge 1886 D. model (with modified priming) placed eighteen in a magazine.

#### 125. Magazines:

The magazine is made out of sheet steel. Its shape is that of a segment of a circle. It is composed of two side plates and two bottom plates forming a box. One of the side plates is solid, the other is bored through allowing a view of the internal part of the magazine.



Ribs secure the stiffness of the magazines and the guiding of the cartridges.

One of the ends is closed with a plate (used as a support for the spring). The nose of the plate protruding externally from the magazine is used to fasten the magazine on the receiver. The other end is open to permit the passing of the cartridges.

Two ears extending from the side plates make it impossible for the cartridges to come out from the magazine unless they are forced to do so by pressure on the cartridge base.

Inside of the magazine, there is a follower whose part is to push the cartridges continuously toward the hole.

This follower is moved by a double bow spring having its immovable support on the magazine closing plate.

#### 126. Loading of the magazine:

To load the magazine: lower the follower with the hand, a distance equal to the thickness of the cartridge.

Engage a cartridge, the base first, let it lie down on the follower; lower this one anew and go on with the loading, lowering progressively the follower, so as to permit the passing of the cartridge to be engaged. The magazine is filled when it contains twenty cartridges (18 gives the best result).

To empty a magazine: push gradually on the base of the cartridges in the same manner the feed piece arm would do in the operation of the rifle.

NOTE.—It will be found advantageous not to keep the magazines filled without necessity, so as not to strain the spring.

#### 127. Seating of the magazine on the rifle:

To seat the magazine on the rifle: cock the rifle, seize the magazine with the right hand, and curve downward, the follower backward.

Place the closing plate, the nose directed upward, between the bipod block and the barrel catch block. Then force the magazine home until it engages the magazine catch.

To disengage the magazine, bring the operating handle to extreme backward position, to secure the hooking of the bolt. Press forward the handle of the magazine, catch, and take off the magazine with the hand. The magazine would, without this precaution, fall down by itself, under the action of the magazines stop spring.



