

# **Selection of Suspension Arrangement of Traction Motors : A Right Approach**

**R.N.Lal ,Senior Executive Director Standards  
Ganesh , Director Standards  
Electrical Directorate  
Research Design and Standards Organisation , Lucknow**

## ***Abstract***

*Motor suspension arrangement is of paramount importance for the reliability of traction motors. Another vital input for the selection of traction motor for given motor suspension arrangement is its rotational speed. Non-availability of any compiled information on the relationship of rotational speed of traction motors and their mounting arrangement makes the jobs of Rolling Stock Engineers difficult. After study of various relevant literatures, various systems followed worldwide and interaction with leading locomotive manufacturers , an effort has been made through this paper to compile various technical issues related with traction motor mounting arrangement and its rotational speed which can be used as a ready reckoner by Rolling Stock Engineers in selecting appropriate system for Indian Railways*

## **1. Introduction**

Even almost after half a century of AC traction on Indian Railways, endless debate starts on type of mounting arrangement and rotational speed of traction motors whenever a decision on new type of rolling stock is to be taken. There is neither compiled information on these issues nor it is taught in universities. Even training institutes on IR have not been able to provide with comprehensive information on the traction motor mounting arrangement and its rotational speed. In the absence of any compiled information on the subject, it becomes difficult for Rolling Stock Engineers to take appropriate decisions, at times.

Mechanical design of traction motors is unique and the design of various types of mounting arrangement of traction motors has got so many significant differences that every locomotive manufacturer have got specialist on power transmission mechanism. We normally come across the terminologies, such as nose suspended traction motor, nose suspended drive, etc which all sound similar to each other, but these two arrangements are entirely different.

Apart from the mounting arrangement of traction motors, their rotational speed is another area where we tend to get carried away by our knowledge of basic electrical machines ,i.e. higher the motor rpm ,lesser the weight of locomotives ( $D^2LN$  for a given rating is constant ,where D is diameter, L is length and N is the rpm).There is nothing wrong in this formula, but when it comes to traction application, there is a definite correlation between rotational speed of motors and their mounting arrangements in bogies. Each type of mounting arrangement of traction motor has got its own advantages and disadvantages, but adopting higher rpm traction motors in axle hung and nose suspended traction motor application has serious repercussion on reliability.

Study of various literatures available on traction motor design and its mounting arrangement has been carried out to understand the subject. Information on these subjects available in technical literatures of various locomotive manufacturers have also been deliberated with experts from ALSTOM, BOMBARDIER, SIEMENS, TOSHIBA, TRAKTION SYSTEME, MITSUBISHI, KAWASHAKI, etc. Various systems followed worldwide on the subject has also been studied.

In this paper, an attempt has been made to explain various types of traction motor mounting arrangement and the effect of motor speed on its performance. It is an endeavor to compile various technical issues related with traction motor mounting arrangement and its rotational speed in this paper which can be used as a ready reckoner by Rolling Stock Engineers in selecting appropriate system for Indian Railways.

## 2. Traction Motor Mounting Arrangement

Traditionally, the biggest challenge for traction motor designers is to design an appropriate mounting arrangement of the motor in the bogie frame. The correct geometric arrangement between rotor shaft and the axle of the wheel set is maintained to ensure that the efficiency and smooth functioning of the transmission between the two (motor shaft and wheel set axle) are fully maintained under all operating conditions.

The traction motor output torque is required to be transmitted to the vehicle axle through reduction gears. The complete power transmission from traction motor through pinion set of gears, etc is called drive arrangement and traction motor can be treated as driver. Based on the fact how traction motor and drive arrangement is mounted in a bogie, following two types of traction motor mounting arrangement in bogies are generally considered worldwide:

- Axle hung nose suspended Traction Motor
- Nose Suspended Drive

However, there are other types of traction motor mounting arrangements such as **undreframe mounted TM**, where TM is mounted in vehicle underframe, driving one or more axles through a flexible drive **and gearless drive** where axle of the wheel set is used as shaft of the rotor, while stator is rigidly mounted to the vehicle body. These arrangements are not very popular and hence discussion in this paper is limited to only axle hung and nose suspended TM and nose suspended drive arrangement.

### 2.1. Nose suspended Traction Motor

This is the most common way of mounting a traction motor in a bogie, is also popularly known as axle hung nose suspended traction motor system. In this arrangement, traction motor is mounted in the bogie frame with its armature shaft parallel to the axle, one side of the motor frame supported on a pair of suspension bearings encapsulated in motor suspension unit in which the axle rotates whereas the other side of the motor is provided with a "nose" which rests on a bracket fixed to the transom of the bogie. A typical arrangement of "nose suspended motor" is shown in Fig. 1 and is still common around the world.

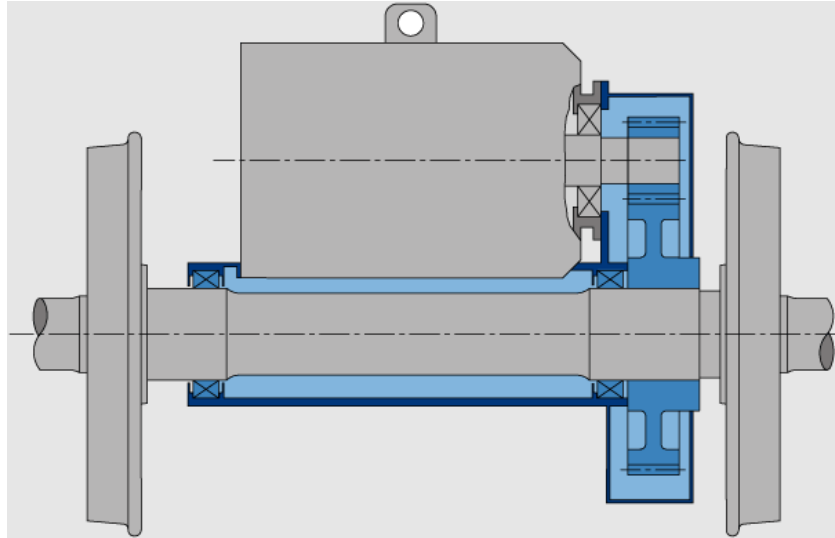

**Fig. 1 : Axle hung and nose suspender traction motor arrangement**

This type of traction motor mounting arrangement provides less shock resistance as almost half of the weight of the motor is rigidly ( without any springing action) mounted on the axle. But, at the same time, this arrangement allows sufficient movement of motor frame relative to the bogie frame to accommodate movement of axle in its axle box guides. Since traction motor axis is always parallel to the axle (subject to diametrical clearances), simplest and most robust form of transmission, i.e. single reduction spur gears are used. This enables accommodating the traction in the least possible space, allowing minimum possible gear-center distance (distance between the axle and the motor shaft). The bogie design in such arrangement has to be suitable to take care of suspended weight of TM on the almost middle of the transom. In our existing fleet, most of bogies on IR (except those of WAP5) are designed for this application. Gear-center distance is a vital design feature which affects following important design parameters:

- Maximum permissible gear ratio
- Minimum possible wheel diameter
- Maximum axle journal diameter at suspension bearing.

Nose suspended traction motor system has got following advantages:

- Because of minimum gear center distance, optimum utilization of the space is possible in bogie which enables maximum size of traction motor in given space envelope.
- Relatively simple and robust and so most economical
- Drive system geometry is independent of bogie primary suspension arrangement.

Major shortcomings and limitations of this arrangement are listed below:

- Due to limited degree of resilience in the traction motor support, motors are directly exposed to high level of shocks generated at wheel treads due to track irregularities. The motor suspension unit and the motor frame must be so designed to accommodate the reaction forces from traction motor gears. Similarly, design of traction motor bearings and motor suspension bearings becomes more critical for the satisfactory performance the traction motor.
- Alignment of the straight spur gear is influenced by the distance between the armature shaft and the axle and the clearances in the two sets of bearings. There is a possibility of tooth end loading and in order to relieve the tooth end loading, pinion teeth shape require special attention, such as taper on tooth ends.
- Because of overhung pinion, the armature shaft deflection causes misalignment of the drive end bearing. This makes the drive end pinion inner racer design complicated. In order to take care of the misalignment, the inner racer of driven end bearing is drowned.
- Because of higher unsprung mass of the traction motor, wheel sets generate shock load to the track ,leading to expensive track maintenance.

#### **2.1.1.Measurement of Level of Shocks and Vibration in nose suspended traction motor arrangement**

IEC 60034-14 recommends testing of axle mounted equipment to be tested for 30g of vibration in vertical direction. But, vibration and shock recorded by various locomotive/EMU manufacturers much higher than what actually recommended by IEC.

Rotor bars are getting crack in traction motors supplied along with electric and diesel locomotives supplied, both, by Bombardier Transportation (BT) and SIEMENS, respectively within few years of service and this severity is more due to wheel slipping action on line during service. In all these applications, traction motors are axle hung and nose suspended. Excessive shock and vibration, much higher than the designed level, directly transmitted from track to traction motors coupled with slipping action on line, are attributed to the main cause of failure of these traction motors. Crack in cages of DE bearing has also been reported after few months in Mumbai suburban area where motors of 3320 rpm in axle hung nose suspended application have been used.

While investigating into cause of rotor bar failure, BT carried out Shock and Vibration Trials on WAG9 Locomotives in Sept'2002 to measure the max. shocks to which traction motors are exposed. This trial was conducted with new as well as worn out gear and pinions. Apart from measurement of shock and vibration, BT carried out the trial to compare the performance of various designs of rotors . Main highlights of their observations after the trial are as under:

- Shock and Vibration recorded in rotors with new gear is 30 g
- Worn out gears show very high accelerations for all speeds ( extremely high factor 6-10 ) Shock and Vibration due to worn out gear was recorded as high as 300 g.
- Starting at critical gradients in bad adhesive conditions however is still critical.

Fig. 2 shows shocks to traction motors recorded on rotors with new and worn out gears respectively.

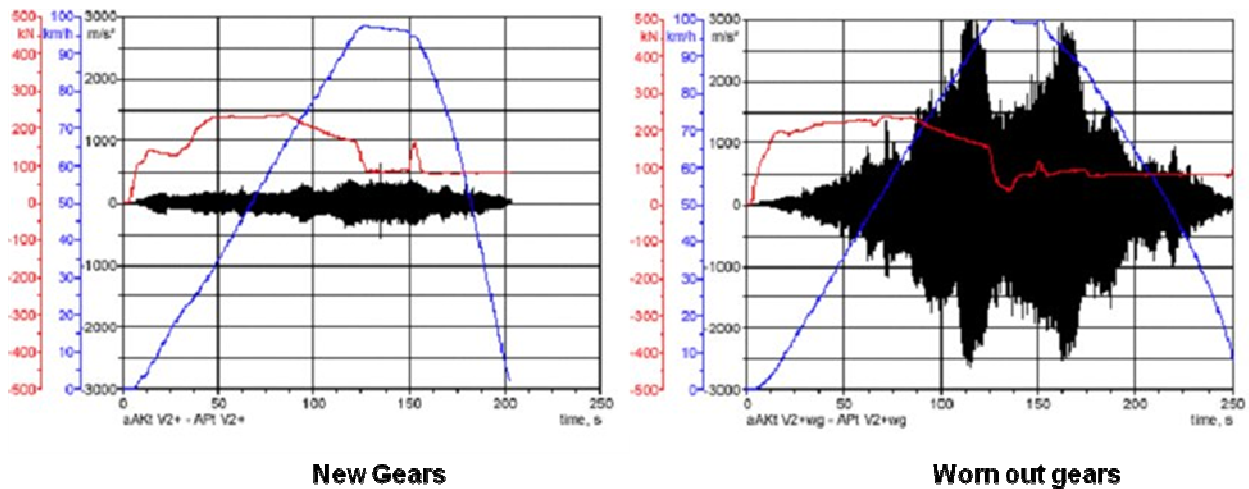

**Fig 2: Shocks recorded during an instrumented trial in WAG9 Locomotive**

While studying the cause of rotor bar cracks in three phase traction motors of GM locomotives ,SIEMENS has carried out Shock and Vibration Trials for GM Diesel Locomotives to ascertain the shocks to which traction motors are subjected . In a similar measurement on diesel-electric locomotives max. shock and vibration recorded was 130g . Pulsating torque and high degree of torsional vibration during starting and at different speeds & braking were also recorded.

SIEMENS has carried out similar trials for MRVC projects in Mumbai sub-urban area before designing the propulsion system. **Max. value : 32 g**

Since motors are directly exposed to shocks and vibration due to track irregularities and wheel spinning or stalling, breakage of rotor bars or bearing seizure due to crack in cage are prominent in axle hung and nose suspended traction motors. Shocks transmitted to the rotors get manifolds with worn out gears.

## 2.2. Nose Suspended Drive

Fundamental disadvantage of nose suspended traction motor i.e, axle hung nose suspension traction motor system is that majority (roughly 60%) of the weight of traction motor and transmission system is unsprung . This arrangement is not suitable at speed above 160 kmph due to higher unsprung mass and so higher forces on tracks.

For high speed application as well as to take advantage of high speed motor for Metro application , normally all locomotive/EMU manufacturers are using fully suspended traction motors in bogie frame with a flexible drive between motor shaft and the axle to allow the

relative movement of bogie frame within the range of the movement of primary suspension .This system is known as nose suspended drive because the transmission mechanism or

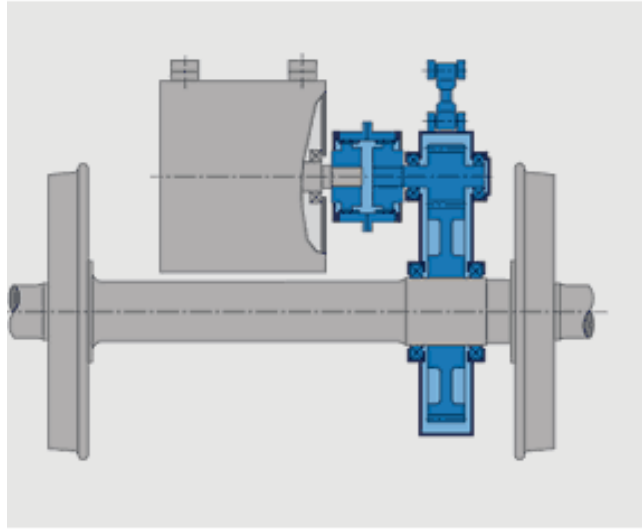

**Fig.3 : Nose suspended drive where Traction Motor is fully suspended in bogie frame.**

the drive comprising of gears , flexible coupling etc. are suspended to bogie. This type of arrangement is also known as frame mounted motor or fully suspended motor arrangement. In this arrangement, complete motor weight is supported in the bogie frame which in turn is supported by the primary suspension of the bogie, as described in Fig.3. Thus, this arrangement reduces the shock loads on the track. Because of flexible coupling between the axle and the motor shaft and motor supported on primary suspension of bogie, reflection of shock and vibration due to track irregularities and arduous operating conditions (wheel spinning) is far less in comparison with nose mounted traction motor arrangement. It requires specially designed bogie for axle hung nose suspended drive application.

In the arrangement of fully suspended traction motor, where traction motor is hung either from bogie or locomotive underframe , instead of directly mounted on axle. Here, traction motor pinion is coupled with gear wheel through an intermediate gear which is flexible in nature. This helps in far less reflection of track irregularities to traction motor in comparison with axle hung nose suspended arrangement. With fully suspended mounting arrangement of traction motors, some locomotives are hauling trains at a speed of 130/150 kmph on IR and have no case of rotor bar breakage in last twelve years. Thus, mounting arrangement is one of the factors affecting rotor life. This has been found true in all other railways, worldwide.

A large number of varieties of such nose suspended drives have been in operation over several decades with certain definite advantages ,of course associated with same shortcomings.

### 3. Practice of Traction Motors Mounting Arrangement followed Worldwide

While approving the design of traction motors for AC-DC EMU for Mumbai sub-urban area, the effect of higher rotational speed on the performance of axle hung nose suspended TMs was discussed in detail. Initially, manufacturer of the electrics offered traction motors with rotational speed more than 4041 rpm. They were asked to share their experience with IR on the performance of traction motors with more than 3000 rpm in axle hung nose suspended TM arrangement. SIEMENS provided following list of TMs along with their application in various Railways:

Project	Country	Qty	Motor type	Gear ratio	Max. motor speed (rpm)	Max. vehicle speed (rpm)	Working since
GP-194/MRVC	India	900	1TB2022	5.71	3452	110	2007
AMTRAK F 69	USA	10	1TB2626	3.59	3590	177	1988
MABI-RENFE	Spain	210	1TB2329	6.31	2950	90	1989-91
SD60-MAC	USA	2308	1TB2630	5.30	3210	113	Since1990
CP-SINTRA	Portugal	400	1TB2222	5.54	3970	120	1991-95
UTLIBERG-BAHN	Switzerland	36	1TB1921	7.40	4000	70	1991
SPOORNET	South Africa	40	1TB2820	6.31	3900	100	1993
SC80/90-MAC	USA	126	1TB2830	5.19	3435	128	1993
EMU 500	Taiwan	692	1TB2021	4.36	3250	110	1994-97
SD70-MAC	USA	2580	1TB2630	5.30	3210	113	Since 1994
NSB-DI8	Norway	90	1TB2325	4.94	3380	120	1995-99
BR152	Germany	680	1TB2822	6.30	4000	140	1996-2001
GT46-MAC	India	361	1TB2622	5.30	3320	120	1997-99
DSB-LOK	Denmark	85	1TB2822	6.29	4000	140	1999-2000
GT46-PAC	India	42	1TB2622	5.30	3784	160	2000
FEVE-LOK	Spain	80	1TB2018	7.10	3300	80	2001-04
BR189/DESPO	Germany	500	1TB2822	6.30	4000	140	2001-05
KOREA	Korea	180	1TB2823	5.89	4000	150	Since 2003

However, efforts have been made to collect information on the mounting arrangements from various sources for some of these traction motors with rotational speed more than 3000 rpm



and their details are discussed here briefly. In the above table , mounting arrangement of traction motors of GT46-MAC and GT46-PAC is axle hung and nose suspended motor system, where as in case of BR152 and DSB-LOK ,it is nose suspended drive. Motor suspension arrangement in other rolling stocks couldn't be ascertained. Listing out rolling stocks with nose suspended drive systems along with those fitted with axle hung and nose suspended motor system in a table giving the performance of the later system(axle hung and nose suspended motor) is misleading.

**Freight Locomotives type BR152** of Deutsche Bahn AG use axle hung drive, designed by SIEMENS and manufactured by VOITH, Germany . Maximum rotational speed in of these traction motors is 3840 rpm for a maximum speed of 140 kmph . These locomotives are in service since 1997.

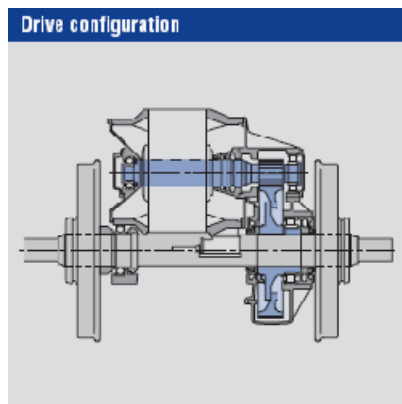

It can be seen above that all these traction motors are having nose suspended drive. These motors are coupled with wheel with flexible coupling.

**DSB-LOK:** Danish State Railways (DSB) placed an order with Siemens AG Germany for thirteen 6-axle Class EG3100 high-performance locomotives for cross-border heavy freight duty. Rotational speed for Traction motor is 4000 rpm for a maximum speed of 140 kmph. Nose-suspended drive unit has been used for motor suspension arrangement. Design of this fleet is based on the Class 152 freight locomotive for German Rail (DB AG) as explained above.

**GT46-PAC for Indian Railways :** At times we get carried away by the maximum rotational speed of the traction motors in various types of suspension system. For example, TMs of passenger version of Diesel locomotives (GT46-PAC) on IR are having maximum rotational speed on 3784 rpm( max designed speed 160 kmph) ,but the locomotive works at a maximum speed of 110 kpmh. Considering 110 kmph as maximum speed of operation, these TMs are operating at a speed less than 2602 rpm.

**GT46-MAC for Indian Railways :** Similarly, TMs of its freight version of these locomotives are designed for 3320 rpm for a max speed of 120 kmph , however at actual operating speed of 75 kmph , max rotational speed is 2075 rpm.



It can be inferred from above that though traction motors in some cases have been designed for more than 3000 rpm for axle hung nose suspended TM mounting arrangement, but in reality their operating rotational speed is always far less than 3000 rpm, as explained above.

All leading manufacturers of locomotives were interacted, e.g. ALSTOM, TOSHIBA, MITSUBISHI, BOMARDIER, etc on rotational speed and suspension arrangement of Traction motors and a summary is given below :

<b>Traction Motor Application</b>	<b>Rotational Speed in rpm</b>	<b>TM Suspension Arrangement</b>
BT for TRAXX Locomotives	2870	Axle hung nose suspended TM
ALSTOM for PRIMA	2800	Axle hung nose suspended TM
TOSHIBA for Chinese Railways	3010	Axle hung nose suspended TM
TGV 24000	4000	Nose suspended drive : Output shaft of the motor is connected to the axle gearbox by a tripod transmission, using sliding cardon (universal-joint) shafts
ALSTOM PENDOLINO Passenger	3600 rpm	Underframe mounted TMs
ALSTOM TGV	3800 rpm	TM fully suspended in bogie.
Shinkansen Double Deck EMU E1 Series	6000 rpm	Parallel cardon drive with gear coupling
Shinkansen Double Deck EMU E4 Series	6000 rpm	Parallel cardon drive with flexible gear coupling
ICE3/Velaro French ,German and Swiss Railway	6000 rpm	Nose suspended drive
US Long Island Railroad EMU by Bombardier	6500 rpm	flexible coupling (is a double, internal and external, self-aligning type of coupling) between gearbox and TM shaft
Nippon-Sharyo built Northern Indiana Transportation District (NICTD)	6000 rpm	single reduction gear unit with flexible coupling between the gearbox and TM shaft.
DMRC Phase II by BOMBARDIER	4746 rpm	Nose suspended drive with an intermediate flexible coupling.

ALSTHOM uses following guidelines while deciding the rotational speed and mounting arrangement of traction motors:

- For freight operation, where the max. speed doesn't exceed 140 kmph , axle hung nose suspended traction motors arrangement is used.
- For max speed over 140 kmph , fully suspended TMs in bogie are used. For very high speed, the traction motor is mounted underframe.
- ALSTHOM has got freight locomotives with maximum rpm of 3290 in axle hung and nose suspended TM arrangement.
- Passenger locomotives having TMs suspended in bogie frame with max rotational speed of 3800 rpm and in another case in Pendolino EMUs , underframe mounted TM with max. rotational speed of 3600 rpm, but most of the time ,service speed of motor is generally less than 3000 rpm.

Guidelines followed by a consortium of three companies TOSHIBA, Mitsubishi and Kawasaki are reproduced below :

- For axle hung nose suspended TM arrangement, max rotational speed is 3187 whereas for nose suspended drive is 6000 rpm . Nose suspended drives are used in high speed trains and commuter trains to emphasize ride quality because of shock and vibration.
- This Japanese consortium has supplied 2914 locomotives with axle hung and nose suspended TM arrangement from 1991 to 2009 to various countries like Japan, China, South Africa and Malaysia and rotational speed of TMs varies from 2036 to around 3000 rpm.

Bombardier has developed locomotive bogie family Class185 for fast freight and passenger services. The maximum speed of the bogie with axle-hung and nose-suspended drive is 140 km/h. The maximum speed is up to 200 km/h for the frame mounted drive system with hollow shaft. Over 700 bogies of this type are currently in service.

Examples are the locomotives type BR145, BR146 and BR185 in Germany and the Re481, Re482, Re484 and Re485 in Switzerland. A typical nose suspended drive used by Bombardier is given below:

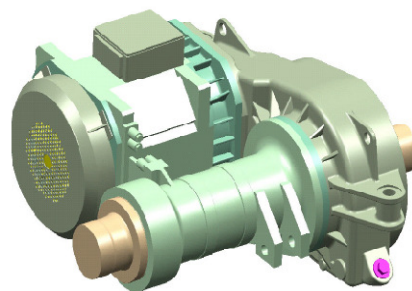

From the discussion above, guidelines followed by leading manufacturers of locomotives can be concluded as under :

- i. For high speed operations, typically above 140-160 kmph , traction motors are either fully suspended or underframe mounted . Rotational speeds of traction motors used here are normally above 3000 rpm in order to get the advantage of reduced weight of TM and less track forces at high speed train operation.
- ii. For low speed operations upto 140 kmph , manufacturers prefer to use axle hung and nose suspended traction motor arrangement and designed rotational speed of these TMs is less than 3000 rpm , but in actual working conditions , they operate at rotational speeds far less than 3000 rpm. For high speed freight train operations, in order to reduce track forces , nose suspended drives are preferred.
- iii. For Metro and EMU application also, high speed motors are being adopted using axle hung nose suspended drive to get the advantage of the light weight. The bogie is specially designed to cater for the need of axle hung nose suspended drive.

#### **4. Rotational speed of traction motors and its mounting arrangement.**

Let us recapitulate the basic relationship between motor RPM and its outer dimensions. Power output of a motor is directly proportional to  $D^2LN$  where D stands for diameter and L for the length of motor whereas N is the rotational speed. For a given power rating of traction motor, higher the rotational speed, smaller is the motor dimensions and vice versa. Smaller motor has got advantages over bigger size motors for a given power rating such as lower losses because of less copper , smaller motor suspension arrangement ,less unsprung mass,etc. Because of smaller motor ,its size of traction motor bearings also reduces. Normally for traction motor applications, only customized bearings are used and their design is governed by specific operating conditions. With smaller bearings , cage dimensions also reduces ,size of rollers and racers are also smaller.

If a traction motor with higher rpm say more than 3000 rpm is used in nose suspended traction motor arrangement, high level of shock and vibration are transmitted to traction motor and bearing components. Weakest part in any bearing is its cage which becomes the first causality of excessive shock and vibration .Fatigue fracture in cages have been experienced in cages of bearings with higher rpm.

IR has got experience of failure of DE bearings in traction motors with rotational speed more than 3000 rpm. Maximum level of shock and vibration recorded in traction motors of EMUs in Mumbai suburban area is 35g. Rotational speed of traction motors used here is 3452 rpm with worn out wheel at 110 kmph. Within six months of the service, there had been series of seizure of DE bearings. Manufacturer of the propulsion system of these EMU rake has carried out detail investigation along with bearing manufacturer. Reason of bearing failure is premature development of crack in bearing cage and excessive clearance between cage and the roller ( 1.4 mm against 0.7 mm). Bearing selected for this application was NU2228 , a rivetless bearing. All the parameters of bearing such as dynamic loading, static loading , limiting speed, etc well within the calculated parameters for bearing design. Bearing manufacturer has customized the standard catalogue bearing for high level of shock and vibration .They removed one roller and strengthened the cage legs, but the clearance between cage and roller was kept as 1.4 mm. Because of direct transmission of shocks due to track irregularities to traction motors , cages developed crack. As a remedial measures, the bearing manufacturer has reduced the cage to roller clearance to 0.7 mm thereby further strengthening the cage .Results of Finite Element Analysis shows reduction in stress in cage with above modification and Haigh's Diagram validates the same. No standard is available to validate the results of FEA by carrying out an

accelerated aging test. IR will have to wait for some time to gain confidence in modified bearing arrangement.

On the other hand, the level of shock and vibration transmitted to the motor component in fully suspended traction motor arrangement is almost negligible because of its mounting arrangement explained above. Here, bearings and its components will have far less magnitude of mechanical shocks.

## 5. Lubrication of Traction Motor Baring

Bearing manufacturer normally use following criteria for selection of lubrication, i.e. grease or oil for a bearing:

For grease lubrication:

$$\min D_m N \leq 60 \times 10^4$$

where  $D_m$  is the mean of outer and inner diameters of bearing and  $N$  is the rotational speed in rpm.

Inner diameter of the bearing is based on the shaft diameter which in turn is decided by the power and torque transmitted by the motor. Higher the power requirement, higher the shaft diameter in order to meet above criterion, rotational speed of the bearing is bound to be less for grease lubricated bearing.

Oil lubricated traction motor bearings use the same gear case oil for lubrication. With the help of main gear wheel, oil is lifted in motion, bearings get the splash of the oil for lubrication. Oil after lubricating trickles down back to the gear case. Oil can be lifted only when oil level is maintained at certain minimum level. Any leakage or damage to gear case leads to the depletion of oil and the moment oil level falls below the minimum level, gear wheel is not able to lift the oil for bearing lubrication which leads to the seizure of bearing. Moreover, during service, because of any reason, if oil level falls below min value, bearings starve for lubrication and damage starts, even if the oil is topped up later. There were number of bearing failures in Western Railway in AC/DC EMU rakes on account of lack of lubrication. Because of stray materials, damage to gear cases is frequent which leads to depletion/leakage and so bearing seizure is inevitable. It is IR's experience that minimum 8 to 10 gear cases are being procured annually by CR and WR respectively for replacement of damaged gear cases and in such cases bearing seizure with oil lubrication is inevitable.

Beside this leakage, wear of gears at higher operating temperature, generates ferrous particles in the oil. Magnetic drain plugs, provided in gear case to attract the ferrous, has never been effective. These ferrous materials work as abrasive materials and when it comes in contact with cage (made of brass) of the bearing along with oil, rub away the brass from the cage. Large number of oil samples from WR and CR have been investigated at Indian Oil R & D Center at Faridabad and reports highlight the fact that higher the ferrous content in the oil, higher is the copper content. This phenomenon is unavoidable which will reduce the life of bearing adversely.

For proper working of gears, viscosity index for gear case oil shall be low, i.e. reasonable level of viscosity of gear case oil is required in order to avoid metal to metal contacts at all the operating temperatures. Once, DE bearing is also lubricated with gear case oil, high viscous oil can't be used in gear case for splash lubrication. This is third major limitations of using oil lubricated bearings.

IR had similar experience with WAG9 locomotives also where DE motor suspension unit (MSU) bearing are lubricated with gear case oil. In order to avoid bearing failure, finally , a decision was taken to segregate the lubrication of DE MSU bearing and gear case oil.

Japanese Railways use grease lubrication for TM bearings even at 6000 rpm of rotational speed.

## **6. Conclusion**

- 6.1. Normally, for passenger applications where high speed train operation is required, in order to reduce track forces, it is desirable to use fully suspended traction motors. For fully suspended motors (nose suspended drive) light weight of traction motor is desirable and so motors with higher rpm are preferred. Because of fully suspended TM, forces from track irregularities or wheel spinning etc. reflected to traction motor components are minimum. That's why even with components with smaller dimensions are working satisfactorily in all high speed applications. In addition to this, in fully suspended TM arrangement, because of intermediate flexible coupling between motor and axle, the space available for the motor is limited and so use of TM with smaller dimensions becomes very useful.
- 6.2. In axle hung nose suspended traction motor arrangement, TM are directly exposed to shocks & vibrations due to track irregularities, wheel spinning and worn out gears. In order to have satisfactory performance of traction motors, their components are bound to be robust which is only possible with larger dimension motors. Because of direct coupling between motor and axle, there is larger envelope available for traction motor in comparison with fully suspended arrangement. Traction motor manufacturers normally take the advantage of available larger envelope in the bogie for traction motors, design motors with lower rpm so that motor components will be of larger dimensions, making them more robust. Only robust motors with adequate dimensions can take the higher shocks and vibrations, as explained above. Hence, traction motors with lower rotational speeds are more appropriate for axle hung and nose suspended arrangement.
- 6.3. As it is evident from above discussion that TM with higher rotational speed needs suitable design of bogies with fully suspended or nose suspended drive arrangement in order to reap advantages like less weight, smaller dimension, etc. for the same power rating. On ,IR except in WAP5 locomotives , all the bogies of other locomotives and EMUs/MEMUs are designed for axle hung and nose suspended TM mounting arrangement .Our compulsion has been to use existing bogies for retrofitment with AC traction motors in order to use the residual life of the fleet. With the existing design of bogies, it is not possible to use fully suspended TM or nose suspended drive arrangement and so the only choice is axle hung and nose suspended TM arrangement. With axle hung nose suspended TM arrangement, motors with lower rotational speed ( 3000 rpm) are the most appropriate for IR type arduous operating conditions .
- 6.4. Because of the problem of leakage and faster wear of gears materials giving rise to higher ferrous contents in oil, it is always recommended to use grease lubricated bearing. Majority of the manufacturers except one or two use separate lubrication of gear case and DE bearings. This leaves the designers more options while selecting gear case oil, best suited to operating conditions.