

Development of Malaccamax Very Large Crude-oil Carriers in Accordance with the Common Structural Rules



TAKASHI FUKAI*1

YASUMITSU KUMA*2

MAKOTO TABIRA*2

Crude oil tankers have been built larger in response to increasing transportation demands and improvements in transportation efficiency after the Second World War (WW II). However, when a large tanker collides or hits bottom, the cargo hold gets damaged, causing an oil spill that has a great impact on the marine environment. To deal with these accidents, rules for tankers have been substantially modified many times. As the degree of these modifications has been relatively large compared with those for other types of vessels, new hull forms and technologies have been developed and applied after each modification. Malaccamax very large crude oil carriers (VLCCs; crude oil tankers with a deadweight of over 200,000 metric tons) are required to comply with a new set of Common Structural Rules (CSRs). They must also have the maximum cargo tank capacity and deadweight, while meeting the principal dimensions restrictions required to sail through the Strait of Malacca, including overall length, breadth, draught, and gross tonnage.

1. Introduction

The first tanker, Mitsubishi Heavy Industries, Ltd. (MHI) constructed after WW II, was the Stanvac Japan, which was handed over in March 1953 and had a capacity of 26,509 metric tons deadweight (DWT). At that time, it was one of the largest tankers in the world. The era of mass crude oil transport using VLCCs started in the late 1960s.

As tankers have been built larger, the amount of spilled crude oil due to accidents relating to groundings and collisions has increased enormously. When the Torrey Canyon went aground in southwest England in 1967, 120,000 tons of crude oil was spilled into the sea.

In this article, the design features of modern VLCCs will be described, and the history of modifications to the rules concerning the structures of large tankers will be outlined. The background of the establishment of the Common Structural Rules (CSRs) and things to keep in mind when applying the CSRs will be discussed.

2. Changes to Large Tankers

2.1 History of VLCCs

The size of tankers has increased at an astonishing pace. After the delivery in 1953 of MHI's first tanker since WW II, MHI delivered the Veedol with 45,834 DWT, to Tide Water Tankers Co. in San Francisco in December 1955. This indicates that the size of tankers had increased almost 1.7 times in only 3 years. The era of supertankers, meaning tankers with capacities of 30,000 to 40,000 DWT, lasted until around 1951. The Naess Sovereign was delivered to Anglo American Shipping Co., Ltd., in January 1951 had a capacity of 88,494 DWT, approximately twice as large as the supertankers. In September 1965, a dock with a capacity of 300,000 metric tons was built in Nagasaki Shipyard & Machinery Works of MHI. The Bergehus was delivered to Sig Bergesen D.Y. & Co. in October 1967, had a capacity of 202,557 DWT, which marked the beginning of the VLCC era. In about 15 years, from March 1953 to October 1967, the size of tankers grew from around 30,000 DWT to approximately 200,000 DWT, an increase of almost a factor of seven. In the next 10 years, VLCCs were continuously constructed (**Figure 1**).

*1 Engineering Manager, Ship & Ocean Engineering Department, Shipbuilding & Ocean Development Headquarters

*2 Ship & Ocean Engineering Department, Shipbuilding & Ocean Development Headquarters

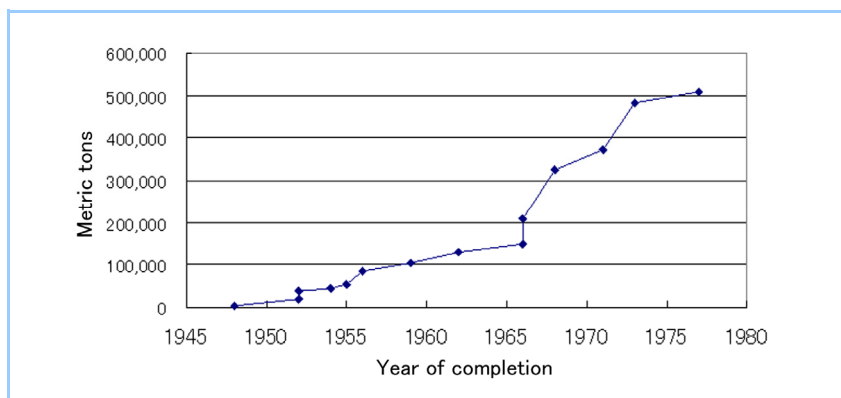

Figure 1 The size of tankers over the last 60 years

From 1976 to 1977, oil tankers with 400,000 DWT were constructed based on orders received before the oil crisis. After the oil crisis in 1975, a period of winter-like hardship for large tankers started, and it took almost 10 years until the construction of VLCCs resumed.

Since the large oil tanker *Tagawa Maru* (239,781 metric tons) was delivered to NYK Line in October 1985, MHI has continuously constructed two types of VLCCs for Japanese ship owners: 240,000 metric ton-class ships and 258,000 metric ton-class ships. Due to tighter regulations that came about to prevent oil spills, double-hull construction was adopted, and size have become slightly larger. These tankers became the new models called Malaccamax VLCCs, described below.

2.2 Outline of Malaccamax VLCC

When transporting crude oil from the Persian Gulf, the world's largest supplier of oil resources, to the Far East region, including Japan, tankers sail about 6,500 miles (approximately 12,000 km) across the Arabian Sea and the Indian Ocean, through the Strait of Malacca to the East China Sea. The hardest part of the route is the Strait of Malacca, located between the Malay Peninsula and the island of Sumatra. The Strait of Malacca is about 900 km long and 70–250 km wide, and the average water depth is about 25 m. As it is very reefy and has a number of places with shallow water, some parts of the watercourse are narrow and shallow and only a few kilometers wide; these are difficult for large ships to pass through.

Malaccamax VLCC is a relatively new name assigned to the largest tanker that can still safely sail through the Strait of Malacca. This largest tanker has increased over time due to improvements in the accuracy of water depth measurement. VLCCs in the past were limited to 250,000 metric tons; however, the latest VLCCs are almost 300,000 metric tons. The main characteristics of MHI's latest Malaccamax VLCC, which conforms to the CSRs, and other existing VLCCs are indicated below in **Table 1** and **Figure 2**.

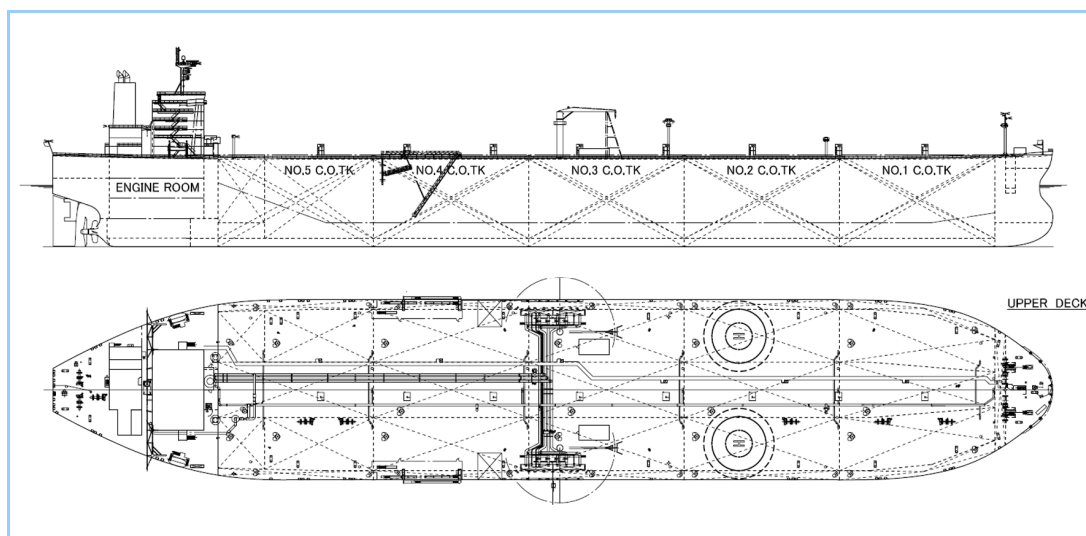

Figure 2 General arrangement plan

Table 1 Comparison of the main characteristics of MHI's VLCCs

	First generation (before the oil crisis)	Second generation		Third generation		
	237 type	240 type	258 type	260 type	300 type (Malaccamax)	CSR applied type 300 (Malaccamax)
Construction period	1971-1976	1985-1992	1986-1995	1999-2000	2004-2006	2011-
Hull structure	Single	Single	Single	Double	Double	Double
Overall length (m)	Approx. 321.8	Approx. 315.5	Approx. 322.0	Approx. 330.0	Approx. 333.0	Approx. 333.0
Length between perpendiculars (m)	304.0	302.0	310.0	319.0	324.0	324.0
Breadth (m)	52.4	58.0	58.0	60.0	60.0	60.0
Depth (m)	25.7	28.3	29.5	28.8	29.1	29.1
Draught (m)	19.85	18.75	19.50	19.22	20.50	20.50
Deadweight tonnage (t)	Approx. 237,000	Approx. 240,200	Approx. 258,000	Approx. 259,999	Approx. 300,000	Approx. 298,500
Cargo tank capacity (m ³)	Approx. 289,100	Approx. 296,000	Approx. 318,000	Approx. 325,000	Approx. 35,000	Approx. 355,000
Gross tonnage (t)	Approx. 118,000	Approx. 137,000	Approx. 147,000	Approx. 152,000	Approx. 160,500	Approx. 160,300
Main engine	Mitsubishi turbine MS-6	Mitsubishi UE 7UEC75LS II	Mitsubishi UE 6UEC85LS II etc.	Mitsubishi UE 7UEC85LS II	Mitsubishi UE 7UEC85LS II	Mitsubishi UE 7UEC85LS II
Main engine output (kW)	25,000	17,000	21,900	27,020	27,020	27,020
Speed (kt)	Approx. 15.8	Approx. 14.5	Approx. 15.5	Approx. 16.2	Approx. 15.5	Approx. 15.5

3. Changing International Conventions

Tankers sailing in the ocean are constructed and operated in accordance with international conventions. The International Convention for the Prevention of Pollution from Ships (MARPOL) has a particularly large influence on the designs of tankers. The changes to MARPOL regulations and the arrangement of tank blocks based on them are described below.

3.1 Changes to MARPOL Regulations

The current MARPOL regulations are based on the International Convention for the Prevention of Pollution of the Sea by Oil (OILPOL), adopted in London in 1954. OILPOL came in effect on July 26, 1958. OILPOL mainly regulates marine pollution caused by routine tanker operations and the discharge of bilge water containing oil from tankers' engine spaces. Amendments were made in 1962 and 1969 to protect the marine environment from oil contamination caused by tank cleaning and the discharge of ballast water. (Ballast water contained oil as it was carried in the tank for the cargo oil at that time.) The 1969 amendments were made in response to the grounding accident of the oil tanker Torrey Canyon in March 1967; the ship spilled her entire cargo of 120,000 tons of crude oil into the English Channel. The 1969 amendments included extending prohibited zones to entire oceans around the world where the discharge of oil is forbidden and imposing tougher standards on tankers in terms of oil discharges. These amendments were adopted at the Inter-government Maritime Consultative Organization (IMCO), the predecessor to the International Maritime Organization (IMO), Convention held in October 1973.

OILPOL was designed to prevent marine pollution caused by routine tanker operations, including tank cleaning and discharges of oily ballast water. However, major spills of cargo oil resulting from grounding accidents were beyond its scope. Meanwhile, tankers have been built larger, and the transportation needs of harmful substances other than oil have increased. In addition, interest in protecting the marine environment has grown in coastal countries. Therefore, the need for an effective international convention covering a broader range of regulations was recognized.

Under these circumstances, the IMCO started working on fundamental reviews of international conventions in 1969, and the International Convention for the Prevention of Pollution from Ships was adopted on November 2, 1973. This convention includes not only heavy oil, which was covered by OILPOL, but also all other kinds of oil, harmful liquid substances, and sewage water, so as to prevent marine pollution in a wider sense. Although the 1973 Convention was never in force, as some of the rules left unresolved issues, after some minor modifications and additions,



it was finally adopted in February 1978 as the original form of the current MARPOL.

Following this, the Marine Environment Protection Committee of the International Maritime Organization (IMO) adopted a law in March 1992 that included a double-hull requirement for new tankers; this law came into force in July 1993. For existing vessels, the Committee also adopted a law that requires gradual elimination (phasing out) of single-hull tankers.

3.2 Changes in tank-arrangement plans adopted to comply with the new conventions

The 2D plans shown below are simple overviews of the tank arrangements of an oil tanker and depict the changes adopted to meet the MARPOL regulations described in Section 3.1 (Table 2). Here, ■ indicates a dedicated ballast tank. These plans are designed to limit the area of the crude oil tank located near the hull by using ballast tanks so that the risk of oil spills caused by ship collisions to the sides of the tanker is reduced.

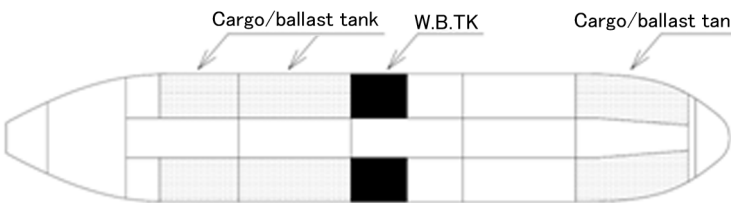
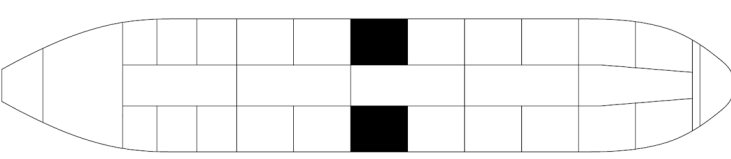
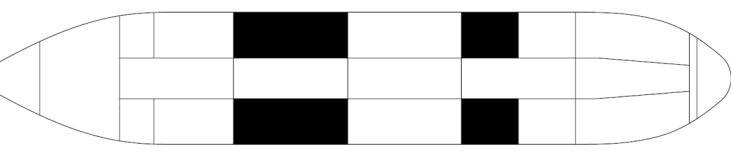
Table 2 Changes in tank arrangements

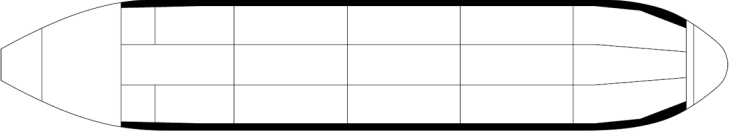
		Tank arrangement
Cargo / ballast tank	Before convention	
	Tank size limitation – 1971	
Segregated ballast tank (SBT)	Rule 13: SBT – 1973	
	Rule 13 E: Protective Location (PL) – 1978	
Segregated ballast tank (guarding the cargo tanks)	Rule 19: Double hull – 1993	

Later, when the double-hull requirement was applied in 1992, the oil tank was surrounded by ballast water tanks both near the hull and along the ship bottom, further reducing the risk of oil spills caused by collisions (Figure 3).

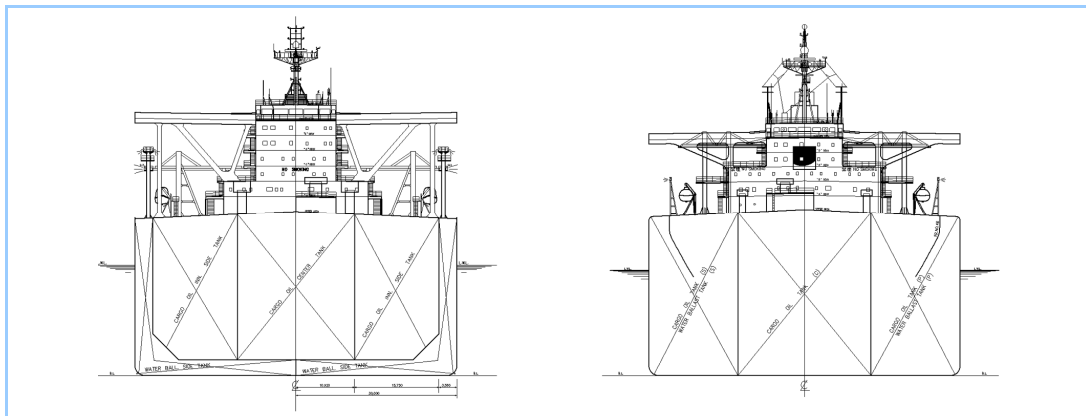

Figure 3 Tank cross-sectional view

4. Establishment and Application of the CSRs

4.1 History of CSR establishment

The CSRs were adopted at the council of the International Association of Classification Societies (IACS), held in December 2005, and came into force on April 1, 2006. The CSRs apply to bulk carriers and double-hull oil tankers.

Ship structural rules include international conventions, codes, and guidelines determined by governments at the IMO, rules made in individual countries, and rules adopted by classification societies.

The classification rules include those set independently by individual classification societies and IACS unified requirements concerning strength of ships.

Despite the tougher rules resulting from the series of international conventions described in Section 3, application of the double-hull requirement, and assessments and inspections after construction and before going into service in accordance with the rules made by the classification societies, a series of major oil spills caused by groundings and other accidents due to structural damage resulting from the lack of fatigue strength have occurred. These accidents include the grounding of the Braer in northern England in 1993, spilling 84,000 tons of crude oil, and the grounding of the Sea Empress in southwest England in 1996, spilling 72,000 tons of crude oil.

To prevent these accidents, the IMO, IACS, and individual classification societies have reviewed rules concerning damage prevention, corrosion-control methods, and periodical surveys of the hull structure during service. Nevertheless, major accidents have still occurred, such as the accident of the Prestige, which sank off the Spanish coast in November 2002, resulting in heightened calls for further improving the structural safety of ships.

Under these circumstances, the IMO set a goal-based safety standard for the hull structure, and the IACS formulated the CSRs for bulk carriers and double-hull oil tankers.

4.2 Application of the CSRs to VLCCs

Currently, designs for VLCCs are in accordance with the CSRs. The CSRs are formulated by unifying and enhancing individual classification rules and have the following characteristics.

- The net thickness approach, which clearly indicates the necessary thickness for strength, corrosion addition and renewal thickness
- Assessments of the hull-girder ultimate bending moment capacity in a sagging condition, which is representative collapse mode of double hull oil tankers
- A large-scale finite-element model analysis, including a detailed structural stress analysis of the toe end of the primary supporting member as well as other parts
- Fatigue strength assessments, focusing on longitudinal stiffeners, such as the side and bottom longitudinals

Other than the application of the CSRs, latest Malaccamax VLCC has the following characteristics:

- Permanent means of access (PMA)

Latest Malaccamax VLCCs have a permanent means of access (PMA) to safely conduct hull structure inspections and thickness measurements in cargo areas. The PMA is designed reasonably by arranging structural members appropriately.

- Structural reliability

Latest Malaccamax VLCCs not only conform to the CSRs, but they also utilize MHI's technical expertise to ensure structural reliability. The spectrum fatigue-strength analysis method (MHI-DILAM: direct loading analysis method) is conducted to analyze the fatigue strength. An advanced fatigue-strength assessment by MHI-DILAM is also conducted. The results are reflected in the actual ship design in addition to meeting the CSR requirements (Figure 4).

Vibration is also considered. In addition to vibration assessment in accommodation areas, assessments based on FEM analyses for primary support members in the cargo tanks are conducted to ensure the structural reliability of the ship.

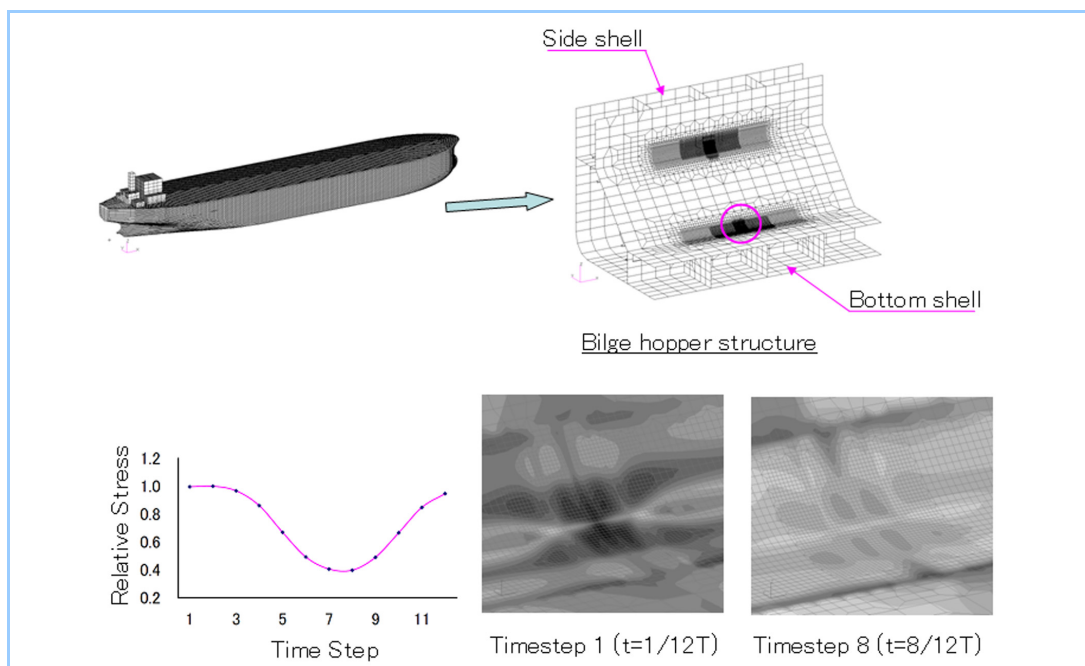

Figure 4 Ensuring structural reliability using advanced testing

5. Conclusion

MHI has provided VLCCs that met needs of the times, such as the demand for larger tankers and environmental concerns, based on a great deal of experience in the construction of large tankers. The latest model of Malaccamax VLCC, which conforms to the CSRs, is currently under construction. By scrutinizing the application of the CSRs to the hull structure, this model fulfils the CSR requirements, ensures sufficient reliability, and deals with the impacts of the CSRs on the weight and capability of the ship in a rational way. Moreover, the new model adopts an energy-saving hull form and a propulsion plant while meeting the restrictions on the principal dimensions required to sail through the Strait of Malacca and to comply with the capacity of terminals where goods are loaded and unloaded. This allows the vessel to efficiently attain a large cargo-carrying capacity and to contribute to both economical transportation and a decrease in environmental burdens, which will satisfy our customers' expectations.

The requirement to provide economical transport while simultaneously achieving a high level of transport safety and decreasing environmental burdens has been increasing. MHI will continue to develop products in the future based on its accumulated technologies to improve safety, reliability, economic efficiency, and environmental friendliness.

References

1. Ohira, H. et al., Changes in Design Concepts of VLCC (in Japanese), Mitsubishi Juko Giho Vol. 25 No.6 (1988-11) pp. 524-528
2. Rules and Guidance for the Survey and Construction of Steel Ships (Part A General Rules) by Nippon Kaiji Kyokai (ClassNK) http://www.classnk.or.jp/hp/down_file/csr/pdf/JCSR-005.pdf
3. 150 Years' History of Mitsubishi Heavy Industries Nagasaki Dockyard and Machinery Works (in Japanese), pp. 398-407