

International Docking System Standard (IDSS)

Interface Definition Document (IDD)

Revision D

April 30, 2015

This page intentionally left blank.

REVISION AND HISTORY

REV.	DESCRIPTION	PUB. DATE
-	Initial Release	09-21-10
A	Revised, rearranged, and added text to nearly all sections of document. Revised & renumbered figures. Added requirements on mechanical soft capture, soft capture sensors, HCS seals, hook stiffness, separation system, electrical bonding, environments, and materials. Added Docking Performance section, and Appendix A.	05-13-11
B	Document Hard Capture System parameter values, figure updates, separation system force addition, editorial correction and updates.	11-15-12
C	Document the narrow ring Soft Capture System (SCS) geometric parameters and update applicable figures. Added Appendix B on Magnetic Soft Capture.	11-20-13
D	Revision D is the first version of the document under NASA configuration control and released by NASA ERU. Revision D includes the following DCNs: DCN 001 DCN 002 DCN 003 DCN 004C DCN 005 DCN 006 DCN 007 DCN 008A DCN 009B DCN 010 DCN 011 DCN 012 DCN 013	08-04-15

This page intentionally left blank.

PREFACE

**INTERNATIONAL DOCKING SYSTEM STANDARD (IDSS)
INTERFACE DEFINITION DOCUMENT (IDD)**

This International Docking System Standard (IDSS) Interface Definition Document (IDD) establishes a standard docking interface to enable on-orbit crew rescue operations and joint collaborative endeavors utilizing different spacecraft.

Configuration control of this document is the responsibility of the International Space Station (ISS) Multilateral Control Board (MCB), which is comprised of the international partner members of the ISS. The National Aeronautics and Space Administration (NASA) will maintain the IDSS IDD under ISS Configuration Management. Any revisions to this document will be approved by the ISS MCB.

CONCURRENCE

<u>/s/ William H. Gerstenmaier</u> William H. Gerstenmaier Associate Administrator Human Exploration and Operations NASA	<u>29 June 2015</u> Date
<u>/s/ Denis Lyskov</u> Denis Lyskov Deputy Head Russian Federal Space Agency	<u>24 July 2015</u> Date
<u>/s/ Thomas Reiter</u> Thomas Reiter Director of Human Spaceflight and Operations European Space Agency	<u>26. June 2015</u> Date
<u>/s/ G Leclerc</u> Gilles Leclerc Director General, Space Exploration Canadian Space Agency	<u>2015 07 06</u> Date
<u>/s/ A. Mori</u> Akinori Mori Deputy Director General Research and Development Bureau Ministry of Education, Culture, Sports, Science, and Technology	<u>8 July 2015</u> Date

This page intentionally left blank.

TABLE OF CONTENTS

PARAGRAPH		PAGE
1.0	INTRODUCTION	1-1
1.1	PURPOSE AND SCOPE	1-1
1.2	RESPONSIBILITY AND CHANGE AUTHORITY.....	1-2
2.0	DOCUMENTS	2-1
2.1	APPLICABLE DOCUMENTS.....	2-1
2.2	REFERENCE DOCUMENTS	2-1
3.0	INTERNATIONAL DOCKING SYSTEM STANDARD.....	3-1
3.1	GENERAL	3-1
3.1.1	SYSTEM DESCRIPTION	3-1
3.1.1.1	DOCKING.....	3-1
3.1.1.2	BERTHING	3-2
3.1.2	ENGINEERING UNITS OF MEASURE	3-2
3.2	MATING INTERFACE DEFINITION	3-2
3.2.1	TRANSFER PASSAGEWAY	3-6
3.2.2	SOFT CAPTURE SYSTEM	3-6
3.2.2.1	GUIDE PETAL SYSTEM	3-9
3.2.2.2	SOFT CAPTURE RING	3-12
3.2.2.3	(DELETED).....	3-13
3.2.2.4	MECHANICAL CAPTURE LATCH SYSTEM.....	3-13
3.2.2.5	SOFT CAPTURE SENSOR ACTUATION	3-16
3.2.2.6	SOFT CAPTURE SENSOR STRIKERS.....	3-16
3.2.3	HARD-CAPTURE SYSTEM	3-17
3.2.3.1	TUNNEL	3-20
3.2.3.2	SEAL	3-20
3.2.3.3	GUIDE PINS AND RECEPTACLES	3-20
3.2.3.4	HARD CAPTURE HOOKS	3-23
3.2.3.5	HARD CAPTURE STRIKER AREAS.....	3-29
3.2.3.6	SEPARATION SYSTEM - GENERAL	3-29
3.2.3.6.1	SEPARATION SYSTEM – FORCE LIMITS.....	3-29
3.2.3.6.2	SEPARATION SYSTEM – ENERGY.....	3-29
3.2.3.7	HCS COMPRESSIVE FORCE RESISTANCE DURING SCS RETRACTION.....	3-30
3.2.4	ELECTRICAL BONDING.....	3-30
3.2.4.1	SOFT CAPTURE SYSTEM	3-30
3.2.4.2	HARD CAPTURE SYSTEM.....	3-30
3.2.5	ENVIRONMENTS.....	3-30
3.2.6	MATERIALS AND SURFACE FINISHES	3-30
3.3	DOCKING PERFORMANCE	3-31
3.3.1	SOFT CAPTURE SYSTEM	3-31
3.3.1.1	INITIAL CONTACT CONDITIONS AND COORDINATE SYSTEMS	3-31
3.3.1.2	VEHICLE MASS PROPERTIES	3-35
3.3.1.3	VEHICLE MOTION LIMITS	3-35

IDSS IDD Revision D
April 30, 2015

3.3.1.4	LOADS	3-35
3.3.2	HARD CAPTURE SYSTEM.....	3-36
3.3.2.1	MATED LOADS.....	3-36
3.4	RESOURCE TRANSFER UMBILICALS.....	3-38
3.4.1	POWER AND DATA TRANSFER UMBILICAL.....	3-39
3.4.1.1	FRAM CONNECTOR PART NUMBER	3-39
3.4.1.2	PDTU CONNECTOR OPERATION.....	3-40
3.4.1.3	CONNECTOR LOCAL COORDINATE SYSTEM	3-41
3.4.1.4	LOCATING REQUIREMENTS	3-42
3.4.1.4.1	LATERAL MOUNTING REQUIREMENTS	3-42
3.4.1.4.2	ROTATIONAL MOUNTING REQUIREMENTS	3-43
3.4.1.4.3	CENTERLINE ANGULAR MOUNTING REQUIREMENTS	3-43
3.4.1.4.4	RETRACTION AND EXTENSION MECHANISM	3-44
3.4.1.4.4.1	RETRACTED POSITION	3-44
3.4.1.4.4.2	EXTENDED POSITION	3-45
3.4.1.5	COMPENSATION OF MISALIGNMENT	3-46
3.4.1.5.1	PLANAR MISALIGNMENT COMPLIANCE	3-46
3.4.1.5.1.1	LATERAL MISALIGNMENT COMPLIANCE.....	3-46
3.4.1.5.1.2	ROTATIONAL MISALIGNMENT COMPLIANCE.....	3-47
3.4.1.5.1.3	RE-CENTERING CAPABILITY.....	3-48
3.4.1.5.1.3.1	RE-CENTERING LATERAL POSITION	3-48
3.4.1.5.1.3.2	RE-CENTERING ROTATIONAL POSITION	3-48
3.4.1.5.1.3.3	RE-CENTERING FORCE.....	3-48
3.4.1.5.2	AXIAL MISALIGNMENT COMPLIANCE	3-48
3.4.1.5.2.1	AXIAL COMPLIANCE.....	3-48
3.4.1.5.2.2	MINIMUM RESISTIVE FORCE	3-48
3.4.1.5.2.3	MAXIMUM CONNECTOR INSERTION FORCE	3-49
3.4.1.5.2.4	ANGULAR COMPLIANCE.....	3-49
3.4.1.5.3	MISALIGNMENT KEEP OUT ZONE	3-50
3.4.1.6	STRUCTURAL LOAD REQUIREMENT	3-50
3.4.1.7	DATA BUS SWITCH STRIKER.....	3-51
3.4.1.7.1	PLANAR MOUNTING REQUIREMENTS.....	3-51
3.4.1.7.2	AXIAL MOUNTING REQUIREMENTS	3-51
3.4.1.7.3	AXIAL LOAD CAPABILITY	3-51
3.4.1.8	PDTU CONNECTOR SHELL CONFIGURATION	3-51
3.4.1.8.1	PDTU RECEPTACLE SHELL DIMENSIONS.....	3-52
3.4.1.8.2	PDTU PLUG SHELL DIMENSIONS	3-52
3.4.1.9	PDTU PIN CONFIGURATION.....	3-55
3.4.1.9.1	POWER TRANSFER PINS	3-59
3.4.1.9.2	DATA TRANSFER PINS	3-60
3.4.1.9.3	PDTU CONNECTOR MATED INDICATION.....	3-60
3.4.2	WATER TRANSFER	3-60
3.4.3	FUEL TRANSFER	3-60
3.4.4	PRESSURANT TRANSFER.....	3-60

IDSS IDD Revision D
April 30, 2015

3.4.5	OXIDIZER TRANSFER	3-60
3.5	DOCKING NAVIGATION AIDS	3-60
3.5.1	PERIMETER REFLECTOR TARGETS	3-63
3.5.1.1	PRT PLACEMENT	3-63
3.5.1.1.1	NUMBER OF PRT RETRO REFLECTORS	3-64
3.5.1.1.2	PRT HEMISPHERICAL RETRO REFLECTOR FIELD OF REGARD.....	3-64
3.5.1.1.3	PRT PLANAR RETRO REFLECTOR FIELD OF REGARD	3-65
3.5.1.1.4	PRT RETRO REFLECTOR FIELD OF REGARD ORIENTATION	3-65
3.5.1.1.5	PRT PLANAR RETRO REFLECTOR BORESIGHT ALIGNMENT	3-66
3.5.1.1.6	PRT REFLECTOR DEPTH.....	3-66
3.5.1.2	REFLECTOR CHARACTERISTICS	3-66
3.5.2	CENTERLINE DOCKING TARGET.....	3-66
3.5.2.1	CDT COORDINATE SYSTEM.....	3-67
3.5.2.2	CENTERLINE VISUAL TARGET.....	3-68
3.5.2.2.1	CVT COMPONENTS.....	3-69
3.5.2.2.2	CDT BACKPLATE LATERAL POSITION MOUNTING TOLERANCE	3-69
3.5.2.2.3	CDT BACKPLATE ANGULAR MOUNTING TOLERANCE	3-69
3.5.2.2.4	CVT STANDOFF ELEMENT HEIGHT.....	3-70
3.5.2.2.5	CVT STANDOFF CROSS LOCATION	3-70
3.5.2.2.6	CVT STANDOFF PARALLELISM.....	3-70
3.5.2.2.7	CVT STANDOFF ELEMENT ROLL ALIGNMENT	3-70
3.5.2.2.8	CDT BACKPLATE DEPTH WITHIN VESTIBULE.....	3-70
3.5.2.2.9	CVT STANDOFF CROSS VISUAL MARKINGS.....	3-70
3.5.2.2.10	CVT VISUAL MARKINGS	3-71
3.5.2.2.11	CVT VISUAL MARKINGS SURFACE	3-73
3.5.2.2.12	CVT COLORS <TBR 3-1>.....	3-73
3.5.2.2.13	SURFACE REFLECTIVITY <TBR 3-2>.....	3-73
3.5.2.3	CENTERLINE REFLECTOR TARGET.....	3-73
3.5.2.3.1	NUMBER OF CRT REFLECTIVE ELEMENTS	3-74
3.5.2.3.2	CRT PATTERN	3-74
3.5.2.3.3	CRT REFLECTOR SIZING.....	3-75
3.5.2.3.4	CRT FIELD-OF-REGARD OBSCURATION	3-76
3.5.2.3.5	CRT REFLECTIVE ELEMENT MATERIAL PEAK LUMINANCE FACTOR	3-76
3.5.2.3.6	CRT REFLECTIVE ELEMENT HALF LUMINANCE ANGLE	3-76
3.5.2.3.7	CRT REFLECTIVE ELEMENT GAIN	3-77
3.5.2.3.8	CRT REFLECTIVE ELEMENT HALF POWER ANGLE	3-77
3.5.2.3.9	CRT REFLECTOR FILTERS.....	3-77
3.5.2.3.9.1	REFLECTIVE FILTER OPERATIONAL WAVELENGTH.....	3-77
3.5.2.3.9.2	MINIMUM RATE OF TRANSMISSION – OPERATIONAL WAVELENGTH	3-77
3.5.2.3.9.3	MAXIMUM RATE OF TRANSMISSION – NON-OPERATIONAL WAVELENGTH	3-77
3.5.3	PERIPHERAL DOCKING TARGET.....	3-77
3.5.3.1	PDT COORDINATE SYSTEM FRAMES.....	3-79
3.5.3.1.1	TARGET A PDT COORDINATE SYSTEM.....	3-80
3.5.3.1.2	TARGET B PDT COORDINATE SYSTEM.....	3-80

**IDSS IDD Revision D
April 30, 2015**

3.5.3.2	PERIPHERAL VISUAL TARGET.....	3-80
3.5.3.3	PERIPHERAL INFRARED TARGET	3-81
3.5.3.4	DEFINITION OF AN INDICATING SURFACE.....	3-81
3.5.3.5	SHORT RANGE REFLECTOR TARGET	3-81
3.5.3.6	PDT STANDOFF POST POSITIONAL MOUNTING TOLERANCE.....	3-81
3.5.3.7	PVT STANDOFF POSTS	3-82
3.5.3.7.1	PVT STANDOFF CIRCLE POSITIONAL MISALIGNMENT	3-82
3.5.3.7.2	PVT STANDOFF CIRCLE ANGULAR MISALIGNMENT.....	3-82
3.5.3.8	PVT VISUAL NAVIGATION FEATURES PLACEMENT.....	3-82
3.5.3.9	PVT CIRCULAR NAVIGATION FEATURE INDICATING SURFACE OUTER DIAMETER ...	3-83
3.5.3.10	PVT CIRCULAR NAVIGATION FEATURE INDICATING SURFACE INNER DIAMETER	3-84
3.5.3.11	PVT CIRCULAR NAVIGATION FEATURE INNER DIAMETER CONCENTRICITY.....	3-84
3.5.3.12	PVT STANDOFF CIRCULAR NAVIGATION FEATURE THICKNESS.....	3-84
3.5.3.13	PVT CIRCULAR NAVIGATION FEATURE DEPTH	3-84
3.5.3.14	PVT CIRCULAR NAVIGATION FEATURE TRANSITION	3-85
3.5.3.15	PVT CIRCULAR NAVIGATION FEATURE MAXIMUM RADIUS OF THE EDGES	3-85
3.5.3.16	PVT CROSSHAIR LENGTH.....	3-85
3.5.3.17	PVT CROSSHAIR WIDTH.....	3-85
3.5.3.18	PVT CROSSHAIR PLACEMENT	3-85
3.5.3.19	PVT CROSSHAIR ALIGNMENT	3-86
3.5.3.20	INDICATING SURFACE CONTINUITY	3-86
3.5.3.21	SHORT RANGE REFLECTOR TARGET REQUIREMENTS	3-86
3.5.3.21.1	NUMBER OF SRRT REFLECTIVE ELEMENTS	3-86
3.5.3.21.2	SRRT REFLECTIVE ELEMENT MATERIAL PEAK LUMINANCE FACTOR.....	3-87
3.5.3.21.3	SRRT REFLECTIVE ELEMENT HALF LUMINANCE ANGLE.....	3-87
3.5.3.21.4	SRRT REFLECTIVE ELEMENT GAIN	3-87
3.5.3.21.5	SRRT REFLECTIVE ELEMENT HALF POWER ANGLE	3-87
3.5.3.21.6	SRRT REFLECTIVE ELEMENT LOCATION.....	3-87
3.5.3.21.7	SRRT FIELD-OF-REGARD OBSCURATION.....	3-87
3.5.3.21.8	SRRT REFLECTOR FILTERS	3-88
3.5.3.21.8.1	REFLECTIVE FILTER OPERATIONAL WAVELENGTH.....	3-88
3.5.3.21.8.2	MINIMUM RATE OF TRANSMISSION – OPERATIONAL WAVELENGTH	3-88
3.5.3.21.8.3	MAXIMUM RATE OF TRANSMISSION – NON-OPERATIONAL WAVELENGTH	3-88
3.5.3.21.9	SRRT REFLECTOR FILTERS MISALIGNMENT	3-89
3.5.3.21.10	SRRT OUT-OF-PLANE REFLECTIVE ELEMENT	3-89
3.5.3.22	PERIPHERAL INFRARED TARGET REQUIREMENTS	3-89
3.5.3.23	PDT STANDOFF ELEMENT HEIGHT.....	3-89
3.5.3.24	PIT/PVT SURFACE CHARACTERISTICS <TBR 3-4>.....	3-89
3.5.3.25	SURFACE GLOSSINESS <TBR 3-5>.....	3-89

APPENDIX

A	ACRONYMS AND ABBREVIATIONS	A-1
B	GLOSSARY <RESERVED>	B-1
C	OPEN WORK	C-1

IDSS IDD Revision D
April 30, 2015

D	HARD CAPTURE SYSTEM HERITAGE STRIKER ZONES.....	D-1
E	MAGNETIC CAPTURE LATCH SYSTEM.....	E-1
F	SYMBOLS DEFINITION.....	F-1

TABLE

3.3.1.1-1	COORDINATE SYSTEMS USED FOR DOCKING MOTION DESCRIPTION.....	3-32
3.3.1.1-2	INITIAL CONTACT CONDITIONS.....	3-34
3.3.1.2-1	VEHICLE MASS PROPERTIES.....	3-35
3.3.1.3-1	VEHICLE MOTION LIMITS.....	3-35
3.3.1.4-1	SCS MAXIMUM INTERFACE LOADS.....	3-36
3.3.1.4-2	SCS MAXIMUM COMPONENT LOADS.....	3-36
3.3.2.1-1	HCS MAXIMUM MATED LOADS.....	3-37
3.3.2.1-2	HCS MATED LOAD SETS.....	3-37
3.4.1.1-1	FRAM CONNECTOR PART NUMBER.....	3-40
3.4.1.9-1	IDSS PDTU CONNECTOR PINOUTS (2 PAGES).....	3-55
3.4.1.9-2	IDSS PDTU CONNECTOR PINOUTS DEFINITIONS (2 PAGES).....	3-56
3.4.1.9-3	UNASSIGNED IDSS PDTU CONNECTOR PINOUTS.....	3-57
3.5.2.3.2-1	CRT REFLECTIVE ELEMENTS LOCATION IN CDT COORDINATE SYSTEM.....	3-75
C-1	TO BE DETERMINED ITEMS.....	C-1
C-2	TO BE RESOLVED ISSUES.....	C-2

FIGURE

3.1.1.1-1	ANDROGYNOUS DOCKING INTERFACE – AXIAL VIEW.....	3-4
3.1.1.1-2	SECTION A-A (CROSS-SECTION THROUGH MID-PLANE OF TWO PETALS).....	3-5
3.1.1.1-3	DETAILED SECTION OF PETAL.....	3-5
3.2-1	NAMING CONVENTION FOR HOOKS, GUIDE PINS, PETALS, LATCHES AND LATCH STRIKERS.....	3-6
3.2.2-1	CAPTURE SYSTEM OVERVIEW.....	3-7
3.2.2-2	STRIKER ZONE DETAIL.....	3-8
3.2.2.1-1	SCS INTERFACE – GUIDE PETAL SYSTEM OVERVIEW.....	3-9
3.2.2.1-2	PETAL DETAIL.....	3-10
3.2.2.1-3	PETAL PROFILE DETAIL.....	3-10
3.2.2.1-4	SECTION E-E - GUIDE PETAL OUTLINE.....	3-11
3.2.2.1-5	SCS INTERFACE – CAPTURE RING PROFILE.....	3-12
3.2.2.3-1	(DELETED).....	3-13
3.2.2.4-1	CROSS SECTIONAL VIEW THROUGH CENTERLINE OF MECHANICAL LATCH STRIKER.....	3-13
3.2.2.4-2	RADIAL VIEW.....	3-14
3.2.2.4-3	TOP VIEW.....	3-15
3.2.2.4-4	ACTIVE MECHANICAL SOFT CAPTURE LATCH INTERFACE.....	3-16
3.2.3-1	HCS INTERFACE - AXIAL VIEW.....	3-18
3.2.3-2	HCS INTERFACE - SENSOR STRIKER ZONE.....	3-19
3.2.3.3-1	GUIDE PIN.....	3-21
3.2.3.3-2	SECTION C-C.....	3-21
3.2.3.3-3	GUIDE PIN RECEPTACLE.....	3-22

IDSS IDD Revision D
April 30, 2015

3.2.3.3-4	SECTION D-D	3-22
3.2.3.4-1	READY TO DOCK CONFIGURATION	3-23
3.2.3.4-2	READY TO HOOK CONFIGURATION.....	3-24
3.2.3.4-3	FULLY MATED CONFIGURATION.....	3-24
3.2.3.4-4	HCS ACTIVE HOOK	3-25
3.2.3.4-5	PASSIVE HOOK.....	3-26
3.2.3.4-6	PASSIVE HOOK DETAIL VIEW	3-27
3.2.3.4-7	HCS ACTIVE HOOK MOTION ENVELOPE	3-27
3.2.3.4-8	LOAD RESPONSE OF ACTIVE HOOK MECHANISM.....	3-28
3.2.3.4-9	LOAD RESPONSE OF PASSIVE HOOK MECHANISM (INCLUDING SPRING WASHER STACK)	3-29
3.3.1.1-1	COORDINATE SYSTEMS OF DOCKING SYSTEM	3-33
3.3.1.1-2	COORDINATE SYSTEM OF DOCKING OBJECTS (ACTIVE AND PASSIVE).....	3-34
3.4-1	UMBILICAL CONNECTOR KEEP-OUT ZONES	3-39
3.4.1.2-1	PDTU ELECTRO-MECHANICAL ACTUATOR CONCEPT OF OPERATION	3-41
3.4.1.3-1	PDTU CONNECTOR LOCAL COORDINATE SYSTEM DEFINITION	3-42
3.4.1.4.1-1	STANDARD POWER/DATA TRANSFER UMBILICAL CONNECTORS	3-43
3.4.1.4.3-1	CENTERLINE ANGULAR MOUNTING REQUIREMENTS	3-44
3.4.1.4.4.1-1	PDTU RETRACTED POSITION.....	3-45
3.4.1.4.4.2-1	PDTU EXTENDED POSITION	3-46
3.4.1.5.1.1-1	PLUG LATERAL COMPLIANCE IN X DIRECTION.....	3-47
3.4.1.5.1.1-2	PLUG LATERAL COMPLIANCE IN Y DIRECTION.....	3-47
3.4.1.5.1.2-1	PLUG ROTATIONAL COMPLIANCE ABOUT THE Z AXIS	3-48
3.4.1.5.2.4-1	RECEPTACLE ANGULAR COMPLIANCE ABOUT X AND Y-AXES	3-50
3.4.1.7.1-1	DATA BUS SWITCH STRIKER GEOMETRY.....	3-51
3.4.1.8.1-1	PDTU RECEPTACLE DIMENSIONS	3-53
3.4.1.8.2-1	PDTU PLUG DIMENSIONS	3-54
3.4.1.9-1	RECEPTACLE (SOCKETS) - FRONT FACE	3-58
3.4.1.9-2	PLUG (PINS) - FRONT FACE.....	3-59
3.5-1	IDSS TARGET SYSTEMS.....	3-61
3.5-2	AVAILABILITY OF DOCKING NAVIGATION AIDS	3-61
3.5-3	REFLECTOR FIELDS OF REGARD	3-62
3.5.1.1-1	PRT LOCATIONS.....	3-64
3.5.1.1.2-1	PERIMETER HEMISPHERICAL REFLECTOR TARGET ASSEMBLY BORESIGHT	3-65
3.5.1.1.3-1	PERIMETER PLANAR REFLECTOR TARGET ASSEMBLY BORESIGHT	3-65
3.5.1.1.4-1	PERIMETER REFLECTOR TARGET ORIENTATION	3-66
3.5.2-1	CENTERLINE DOCKING TARGET.....	3-67
3.5.2.1-1	CDT COORDINATE SYSTEM.....	3-68
3.5.2.2.2-1	CVT ALIGNMENT	3-69
3.5.2.2.9-1	STANDOFF CROSS VISUAL MARKINGS DIMENSIONS	3-71
3.5.2.2.10-1	CDT BACKPLATE VISUAL ALIGNMENT MARKINGS	3-72
3.5.2.2.10-2	CDT BACKPLATE POLYGON MARKINGS	3-73
3.5.2.3.2-1	LOCATIONS OF CRT REFLECTIVE ELEMENTS	3-75
3.5.2.3.4-1	CRT UNOBSCURED FIELD-OF-REGARD DEFINITION.....	3-76
3.5.3-1	PERIPHERAL DOCKING TARGET.....	3-78

IDSS IDD Revision D
April 30, 2015

3.5.3-2	PERIPHERAL DOCKING TARGET COMPONENTS AND FUNCTIONS.....	3-79
3.5.3.1-1	PDT COORDINATE SYSTEM FRAMES.....	3-80
3.5.3.6-1	LOCATION OF THE PDT STANDOFF POSTS WITH RESPECT TO THE PASSIVE SCS RING COORDINATE SYSTEM.....	3-82
3.5.3.8-1	CIRCULAR NAVIGATION FEATURE LOCATIONS.....	3-83
3.5.3.9-1	CIRCULAR NAVIGATION FEATURE DETAILS.....	3-84
3.5.3.16-1	PDT CROSSHAIR DETAILS	3-85
3.5.3.18-1	PVT CROSSHAIR LOCATIONS.....	3-86
3.5.3.21.7-1	SRRT UNOBSCURED FIELD-OF-REGARD DEFINITION	3-88
D-1	HCS COMPONENT STRIKER ZONE REFERENCE NUMBERS	D-2
D-2	APAS FEATURES WITHIN STRIKER ZONES	D-3
D-3	NDS FEATURES WITHIN STRIKER ZONES	D-4
E-1	CROSS SECTIONAL VIEW THROUGH CENTERLINE OF MAGNETIC LATCH STRIKER.	E-2
E-2	RADIAL VIEW	E-3

1.0 INTRODUCTION

This International Docking System Standard (IDSS) Interface Definition Document (IDD) is the result of a collaboration by the International Space Station membership to establish a standard docking interface to enable on-orbit crew rescue operations and joint collaborative endeavors utilizing different spacecraft.

This IDSS IDD details the physical geometric mating interface and design loads requirements. The physical geometric interface requirements must be strictly followed to ensure physical spacecraft mating compatibility. This includes both defined components and areas that are void of components. The IDD also identifies common design parameters as identified in section 3.0, e.g., docking initial conditions and vehicle mass properties. This information represents a recommended set of design values enveloping a broad set of design reference missions and conditions, which if accommodated in the docking system design, increases the probability of successful docking between different spacecraft.

This IDD does not address operational procedures or off-nominal situations, nor does it dictate implementation or design features behind the mating interface. It is the responsibility of the spacecraft developer to perform all hardware verification and validation, and to perform final docking analyses to ensure the needed docking performance and to develop the final certification loads for their application.

While there are many other critical requirements needed in the development of a docking system such as fault tolerance, reliability, and environments (e.g. vibration, etc.), it is not the intent of the IDSS IDD to mandate all of these requirements; these requirements must be addressed as part of the specific developer's unique program, spacecraft and mission needs. This approach allows designers the flexibility to design and build docking mechanisms to their unique program needs and requirements.

1.1 PURPOSE AND SCOPE

The purpose of the IDSS IDD is to provide basic common design parameters to allow developers to independently design compatible docking systems. The IDSS is intended for uses ranging from crewed to autonomous space vehicles, and from Low Earth Orbit (LEO) to deep-space exploration missions.

This document defines docking system interface definitions supporting the following missions:

- A. International Space Station (ISS) visitation
- B. Exploration missions beyond LEO
- C. Crew rescue
- D. International cooperative missions

Vehicles using this interface may include light vehicles in the range of 5-8 tonnes, and medium vehicles in the range of 8-25 tonnes. These vehicles will dock to each other, to large space complexes in the range of 100-375 tonnes, and to large earth departure stages in the range of 33-170 tonnes. The figures and tables in this document depict the

IDSS IDD Revision D
April 30, 2015

features of the docking interface that are standardized. Some docking features (e.g. sensors, separation systems) are not standardized and are left to the discretion of docking system designers, though they must follow the designated striker zone requirements. Resource umbilicals are not yet standardized and are not yet defined in this standard.

1.2 RESPONSIBILITY AND CHANGE AUTHORITY

Any proposed changes to the IDSS by the participating partners of this agreement shall be brought forward to the IDSS committee for review.

Configuration control of this document is the responsibility of the International Space Station (ISS) Multilateral Control Board (MCB), which is comprised of the international partner members of the ISS. The National Aeronautics and Space Administration (NASA) will maintain the IDSS IDD under ISS Configuration Management, until an appropriate International Standards Body is identified and mutually agreed.

2.0 DOCUMENTS

2.1 APPLICABLE DOCUMENTS

The following documents include specifications, models, standards, guidelines, handbooks, and other special publications. The documents listed in this paragraph are applicable to the extent specified herein.

SSQ 22680 (current issue)	Connectors, Rectangular, (ORU), Space Quality, General Specification For
------------------------------	--

2.2 REFERENCE DOCUMENTS

The following documents contain supplemental information to guide the user in the application of this document. These reference documents may or may not be specifically cited within the text of this document.

AMS 2700	Passivation of Corrosion Resistant Steels
AMS-4027	Aluminum Alloy, Sheet and Plate, 1.0Mg - 0.60Si - 0.28Cu - 0.20Cr (6061; -T6 Sheet, -T651 Plate), Solution and Precipitation Heat Treated
AMS QQ-A-200/8	Aluminum Alloy 6061, Bar, Rod, Shapes, Tube and Wire, Extruded
ASME B46.1	Surface Texture (Surface Roughness, Waviness and Lay)
ASTM A582	Standard Specification for Free-Machining Stainless Steel Bars
ASTM D523-14	Standard Test Method for Specular Gloss
ASTM E408-13	Standard Test Methods for Total Normal Emittance of Surfaces Using Inspection-Meter Techniques
ASTM E903-12	Standard Test Method for Solar Absorptance, Reflectance, and Transmittance of Materials Using Integrating Spheres
ISO 2813	Paints and Varnishes. Measurement of specular gloss of non-metallic paint films at 20°, 60° and 85°
ISO 5843-4:1990	Aerospace - List of equivalent terms - Part 4: Flight dynamics
MIL-C-26074	Electroless Nickel Coatings
MIL-DTL-5002	Surface Treatments And Inorganic Coatings For Metal Surfaces Of Weapons Systems

IDSS IDD Revision D
April 30, 2015

MIL-L-46010

Lubricant, Solid Film, Heat Cured, Corrosion Inhibiting

3.0 INTERNATIONAL DOCKING SYSTEM STANDARD

3.1 GENERAL

The following subsections describe the system interfaces for the IDSS.

3.1.1 SYSTEM DESCRIPTION

3.1.1.1 DOCKING

The IDSS IDD presumes a pre-docking rendezvous phase along with a 2-stage approach to docking. The rendezvous stage involves an active docking vehicle navigating to the passive docking vehicle to align their docking interfaces for the docking stage. The passive vehicle provides three types of targets to assist the active vehicle in performing the precise alignment needed to mesh the mechanical interfaces at the start of the docking stage. Targets are available for longer to mid-range operations, as well as for short-range operations when the active vehicle is on the docking axis of the passive vehicle. These shorter range targets are available to the active vehicle for alignment to within the capture envelope specified by the docking system's Initial Contact Condition requirements. This completes the rendezvous stage.

The first stage of docking establishes the initial capture of the docking vehicles, and is performed by the Soft Capture System (SCS). During the capture phase, the active docking mechanism's SCS aligns with and latches to the passive docking mechanism, then stabilizes the newly joined spacecraft relative to each other. The soft capture system then pulls the docking spacecraft together in order to initiate the second stage of docking, performed by the Hard Capture System (HCS). The HCS performs structural latching and sealing at the docking interface in order to transfer structural loads between the spacecraft and to create a transfer tunnel which can be pressurized for crew and cargo transfer for joint mission operations. The docking operation needs to be completed within a maximum time to ensure a safe docking operation.

The IDSS docking interface is fully androgynous about one axis, meaning the interface configuration is capable of mating to an identical configuration. During docking, one androgynous soft capture interface must be active (active mode), while the other androgynous soft capture interface remains retracted and locked in place, or passive (passive mode). The active interface controls the soft capture function and all sequences of docking through hard capture. Figure 3.1.1.1-1, Androgynous Docking Interface – Axial View and the Androgynous Docking Interface – Cross Sections [Figures 3.1.1.1-2, Section A-A (Cross-section through mid-plane of two petals) and 3.1.1.1-3, Detailed Section of Petal] depict the Androgynous IDSS interface.

The androgynous SCS interface consists of a capture ring, guide petals, mechanical latches, mechanical latch strikers, sensors and sensor strikers. The term "striker" refers to the area on the passive side of the mating interface which is intended to be a contact surface for an active component on the active side of the mating interface. During docking soft capture, the guide petals are the first element to make contact; this is

IDSS IDD Revision D
April 30, 2015

referred to as initial contact. The SCS then responds to correct the lateral and angular misalignment between the two opposing interfaces. Soft capture is complete when the two capture rings are in full contact and the active mechanical capture latches are fully engaged with the mechanical latch strikers on the opposing vehicle.

The SCS then aligns the two mating vehicles and retracts to bring the two hard capture interfaces into hard capture range. Fine alignment is accomplished by a combination of SCS retraction and HCS guide pins.

The HCS uses active hooks to engage opposing passive hooks to provide the structural connection and pressure seal compression. The HCS interface consists of a tunnel, 12 active/passive hook pairs on each side, dual concentric pressure seals, fine alignment guide pins and guide pin receptacles, sensors, sensor strikers, separation system, and resource umbilicals.

The docking operation is complete when the mechanical hooks and resource umbilicals are fully engaged.

3.1.1.2 BERTHING

Berthing spacecraft together using a mechanical robot arm has been a crucial capability for spaceflight operations. This capability has been used extensively as part of the United States Space Shuttle and ISS programs. This international docking standard interface will not preclude robotic assisted berthing by the ISS Space Station Remote Manipulator System (SSRMS) (or an equivalent system) if the total force required to enable soft capture is less than 150N. The primary method for berthing utilizes a fully functional soft capture system.

3.1.2 ENGINEERING UNITS OF MEASURE

All dimensions are in millimeters. All angular dimensions are in degrees. Unless otherwise specified, the dimensional tolerances shall be as follows:

xx implies $xx \pm 1$ mm

xx.x implies $xx.x \pm 0.5$ mm

xx° implies $xx^\circ \pm 30'$

3.2 MATING INTERFACE DEFINITION

An overview of the IDSS interface is shown in Figure 3.1.1.1-1. The IDSS docking interface shall conform to the definition as shown in Figure 3.1.1.1-2 and Figure 3.1.1.1-3. The HCS Mating Plane is defined as the seal plane between two vehicles' HCS tunnels when structurally mated.

Two reference lines are a Line of Androgyny and a Line of Symmetry as shown in Figure 3.1.1.1-1. The Docking Axis is defined as shown in Figure 3.1.1.1-2.

IDSS IDD Revision D
April 30, 2015

Figure 3.2-1, Naming Convention for Hooks, Guide Pins, Petals, Latches and Latch Strikers, defines the naming convention for the Docking system principal components.

The SCS Mating plane is defined as the plane normal to the Soft Capture Ring's axis which intersects the conic outline of the Guide Petals at a diameter of 1200 mm.

The SCS mating plane is the top surface of the capture ring for both active and passive modes.

Unless otherwise stated, the dimensions and features called out in section 3.2 and its subsections shall be implemented on IDSS-compatible systems; these are requirements which must be met to ensure docking interface compatibility. Each requirement dimension is specified only once with its required value and tolerance. For increased clarity, some requirement dimensions are repeated elsewhere without tolerance, and are marked with "REF". "REF" stands for "REFERENCE", and denotes a repeated callout of a primary requirement dimension that can be found elsewhere in this document. Some dimensions in the figures are enclosed in braces, i.e. "{ }". These dimensions are not a requirement of the standard, but are dimensions from existing proven heritage systems. Deviations from these dimensions may be possible. A complete list of drawing symbols used throughout the document is identified in Appendix F.

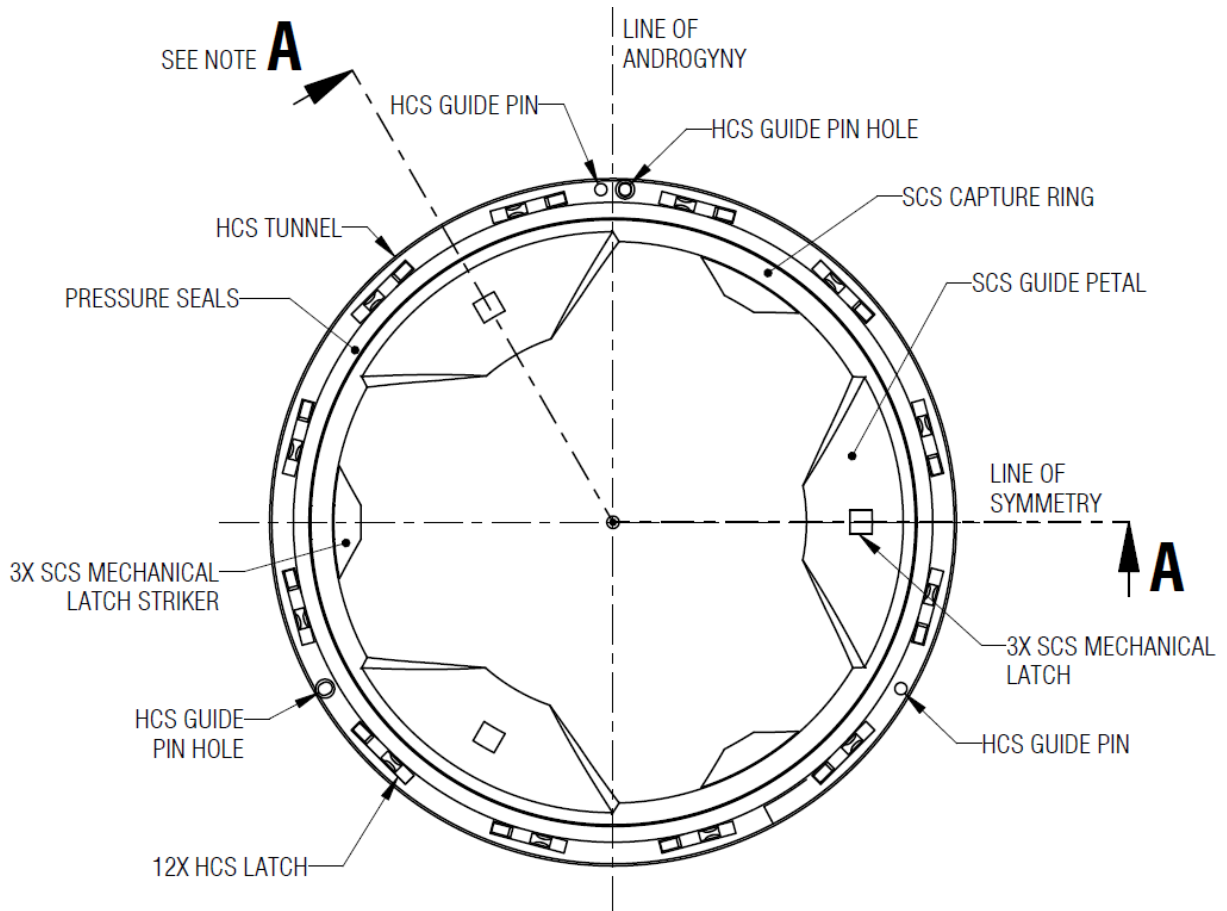

Note: Refer to Figure 3.1.1.1-2 for Section A-A.

FIGURE 3.1.1.1-1 ANDROGYNOUS DOCKING INTERFACE – AXIAL VIEW

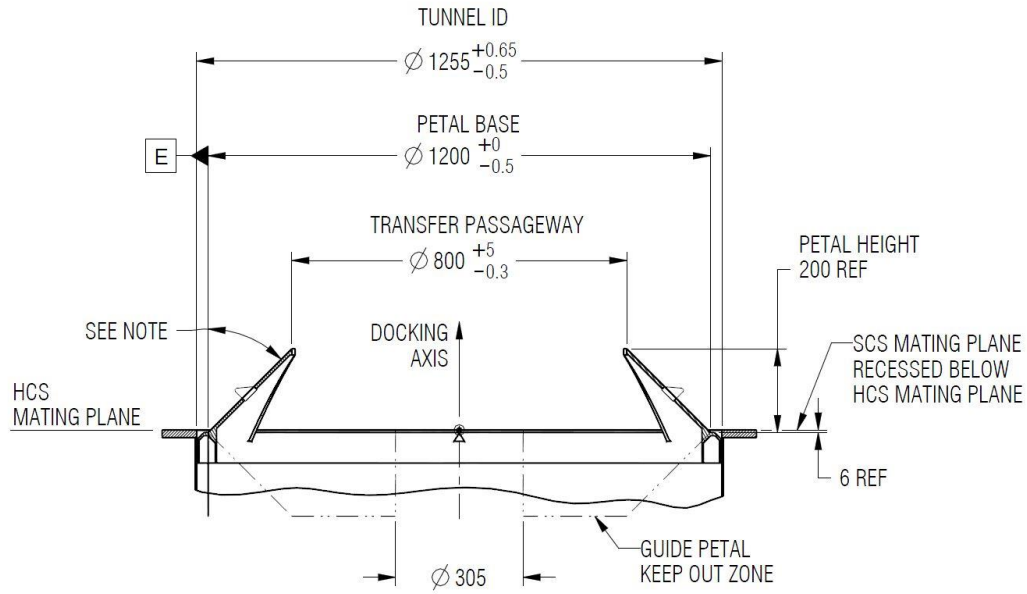

Note: Refer to Figure 3.1.1.1-3 for details

FIGURE 3.1.1.1-2 SECTION A-A (CROSS-SECTION THROUGH MID-PLANE OF TWO PETALS)

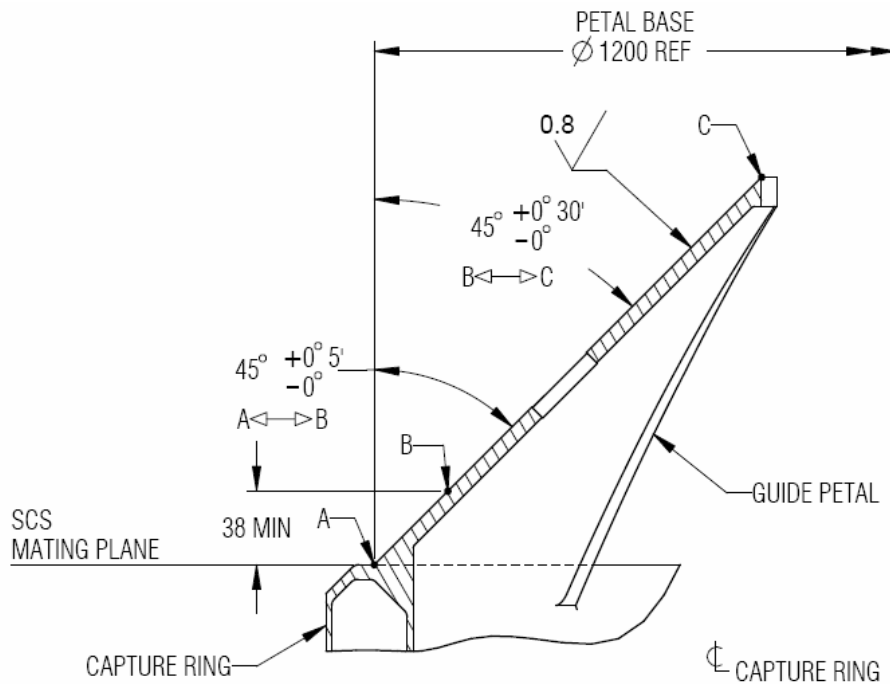
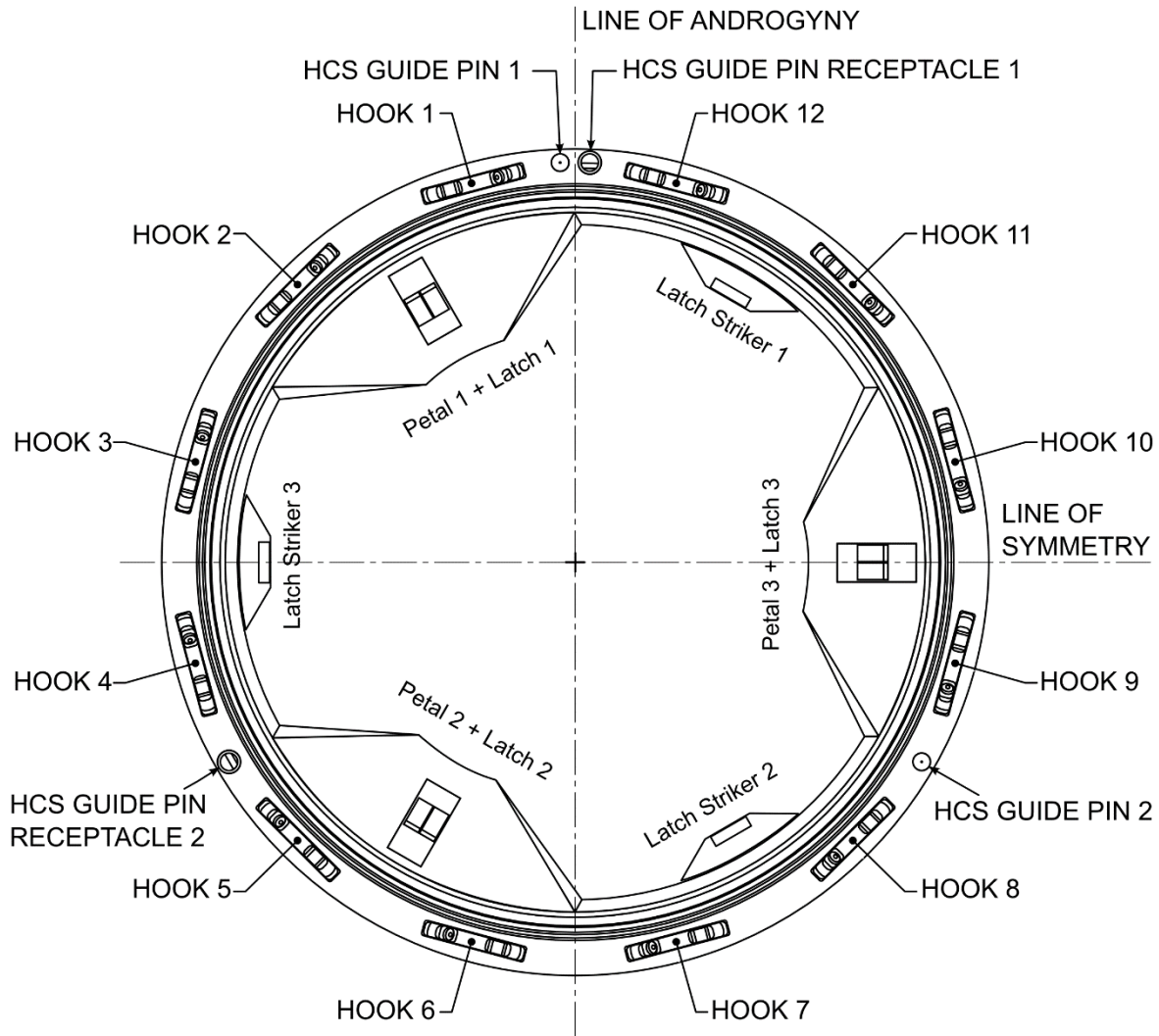

FIGURE 3.1.1.1-3 DETAILED SECTION OF PETAL



Note: The naming convention given here is to provide a common way to reference these items, and it is the designer's choice whether, or how, to place physical labels on the items themselves.

FIGURE 3.2-1 NAMING CONVENTION FOR HOOKS, GUIDE PINS, PETALS, LATCHES AND LATCH STRIKERS

3.2.1 TRANSFER PASSAGEWAY

The docking system shall maintain the minimum transfer passageway diameter as shown in Figure 3.1.1.1-2.

3.2.2 SOFT CAPTURE SYSTEM

The SCS performs soft capture using mechanical capture latches with mechanical strikers. The capture system shall conform to the definition as shown in the SCS

IDSS IDD Revision D
April 30, 2015

Interface - Capture System [Figure 3.2.2-1, Capture System Overview, and Figure 3.2.2-2, Striker Zone Detail]. Soft capture is the initial mechanical mating between the docking systems. It is the first stage of attachment in the docking sequence for the purpose of soft capture system docking interface alignment, capture, arrest and stabilization of dynamic motion between the spacecraft, and finally, interface alignment prior to hard capture system engagement.

An alternative concept for a capture system based on magnetic capture - which would be compatible with mechanical latches - is described in Appendix E.

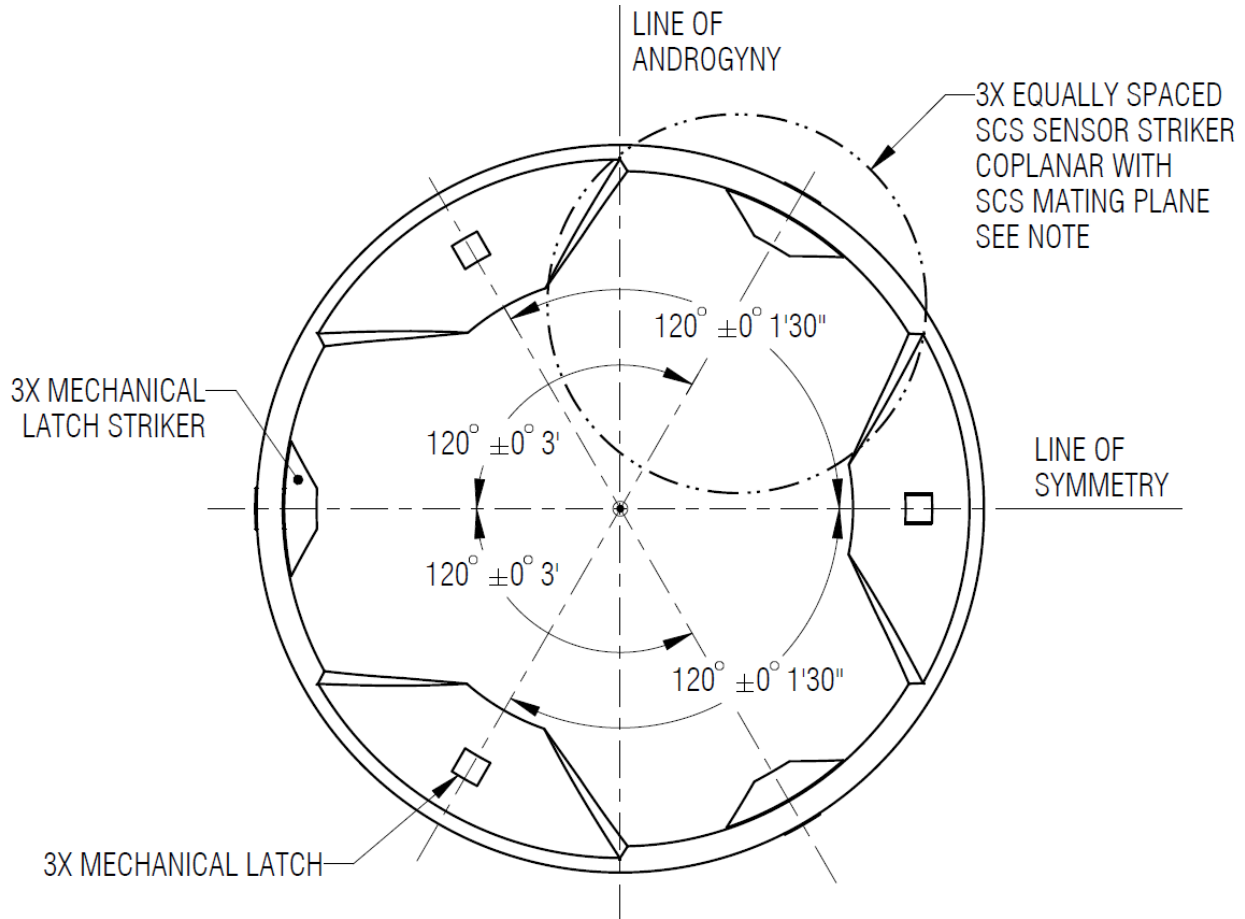

Note: Refer to Figure 3.2.2-2 for Striker Zone details

FIGURE 3.2.2-1 CAPTURE SYSTEM OVERVIEW

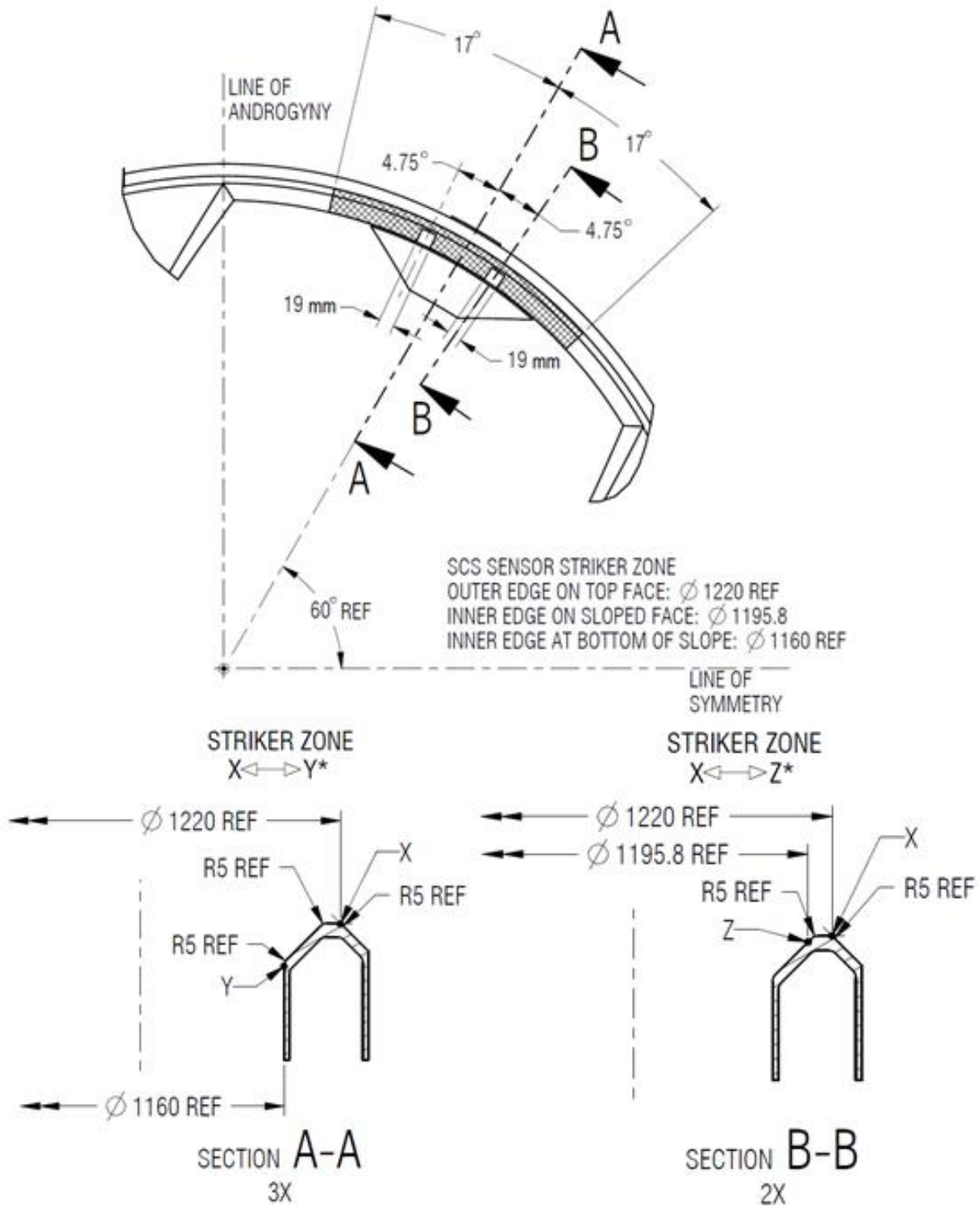

* SCS sensor striker zone is the actual contour of the capture ring surfaces as shown.

FIGURE 3.2.2-2 STRIKER ZONE DETAIL

3.2.2.1 GUIDE PETAL SYSTEM

IDSS compliant systems shall implement three inward pointing guide petals integrated on the soft capture ring. The petals shall be equally spaced around the circumference of the soft capture docking ring as shown in Figure 3.2.2.1-1, SCS Interface – Guide Petal System Overview. Additional SCS interface details that shall be implemented are shown in the SCS Interface – Guide Petal System Details [Figures 3.2.2.1-2, Petal Detail, 3.2.2.1-3, Petal Profile Detail, and 3.2.2.1-4, Section E-E – Guide Petal Outline] and Figure 3.2.2.1-5, SCS Interface – Capture Ring Profile.

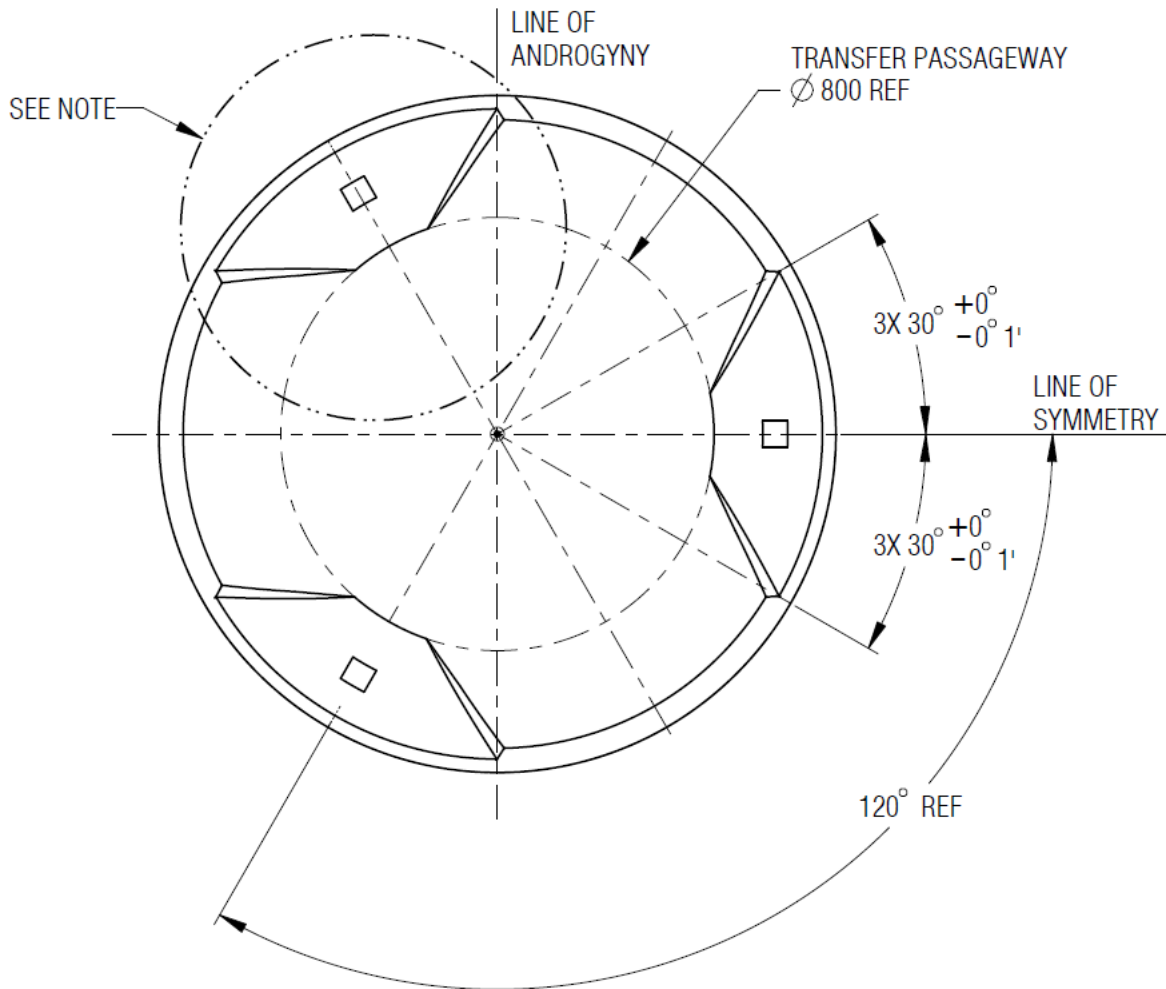

Note: Refer to Figure 3.2.2.1-2 and Figure 3.2.2.1-3 for Petal details.

FIGURE 3.2.2.1-1 SCS INTERFACE – GUIDE PETAL SYSTEM OVERVIEW

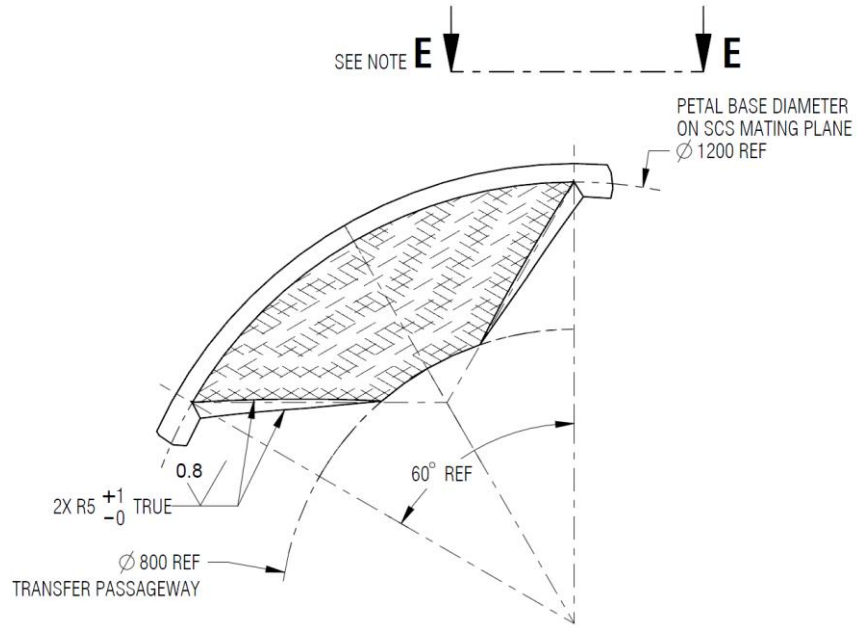

Note: Refer to Figure 3.2.2.1-4 for View E-E

FIGURE 3.2.2.1-2 PETAL DETAIL

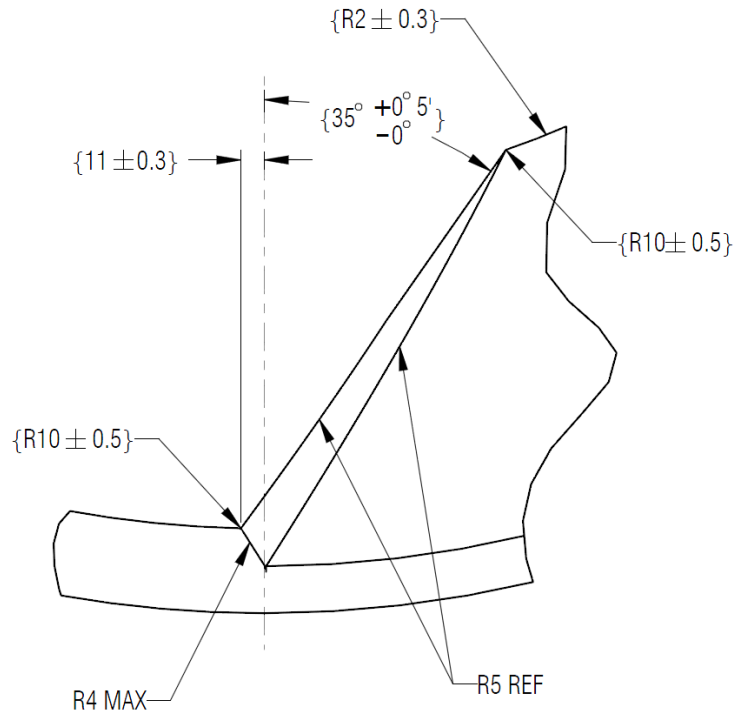
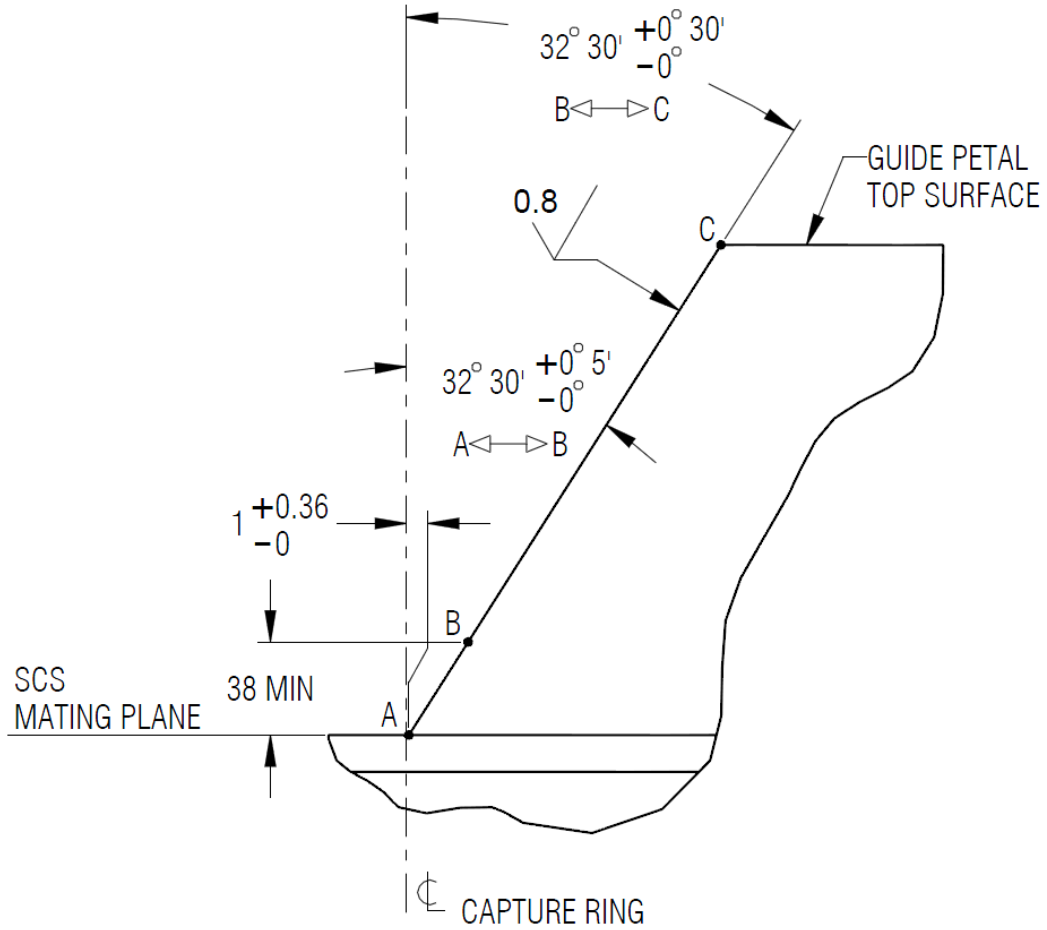

FIGURE 3.2.2.1-3 PETAL PROFILE DETAIL



Notes: In Petal Detail view, dimensions projected on the SCS mating plane are shown.

Petal outline shown is on the external conic surface of the petal system.

FIGURE 3.2.2.1-4 SECTION E-E - GUIDE PETAL OUTLINE

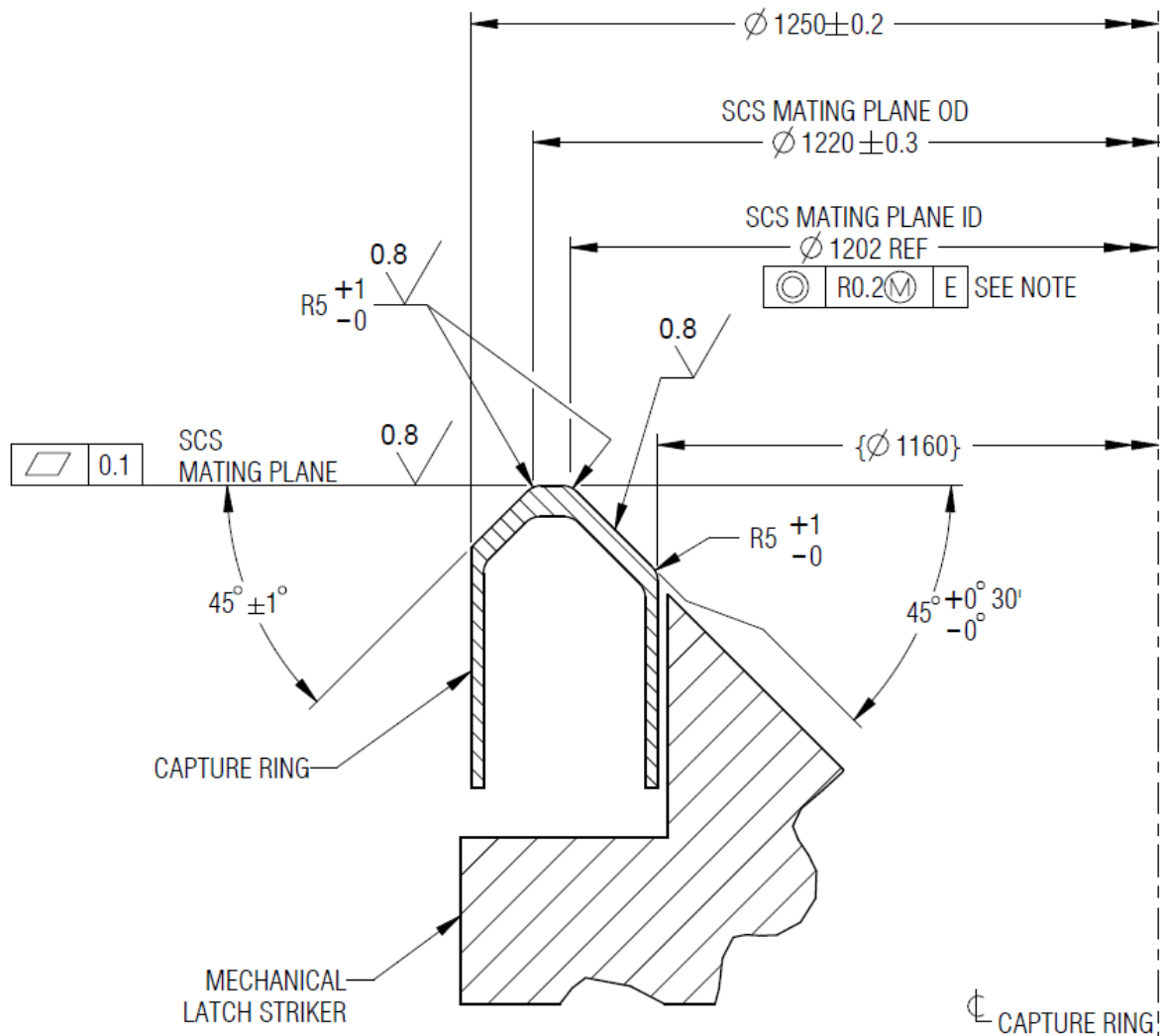

Note: Datum E is defined in Figure 3.1.1.1-2.

Cross Section View of Capture Ring in Passive Mode through the Striker

FIGURE 3.2.2.1-5 SCS INTERFACE – CAPTURE RING PROFILE

3.2.2.2 SOFT CAPTURE RING

The SCS Ring is retracted and held firmly in place below the HCS mating plane when in passive mode. In active mode, the SCS Ring is actuated above the HCS mating plane to perform soft capture.

3.2.2.3 (DELETED)

FIGURE 3.2.2.3-1 (DELETED)

3.2.2.4 MECHANICAL CAPTURE LATCH SYSTEM

The IDSS SCS interface includes three mechanical latch strikers to accommodate mechanical latching systems as shown in Figures 3.2.2-1 and 3.2.2-2. The mechanical latches and strikers shall conform to the definition of the Latch Striker for Mechanical Systems shown in Figures 3.2.2.4-1, Cross Sectional View through Centerline of Mechanical Latch Striker; 3.2.2.4-2, Radial View; and 3.2.2.4-3, Top View; and Figure 3.2.2.4-4, Active Mechanical Soft Capture Latch Interface.

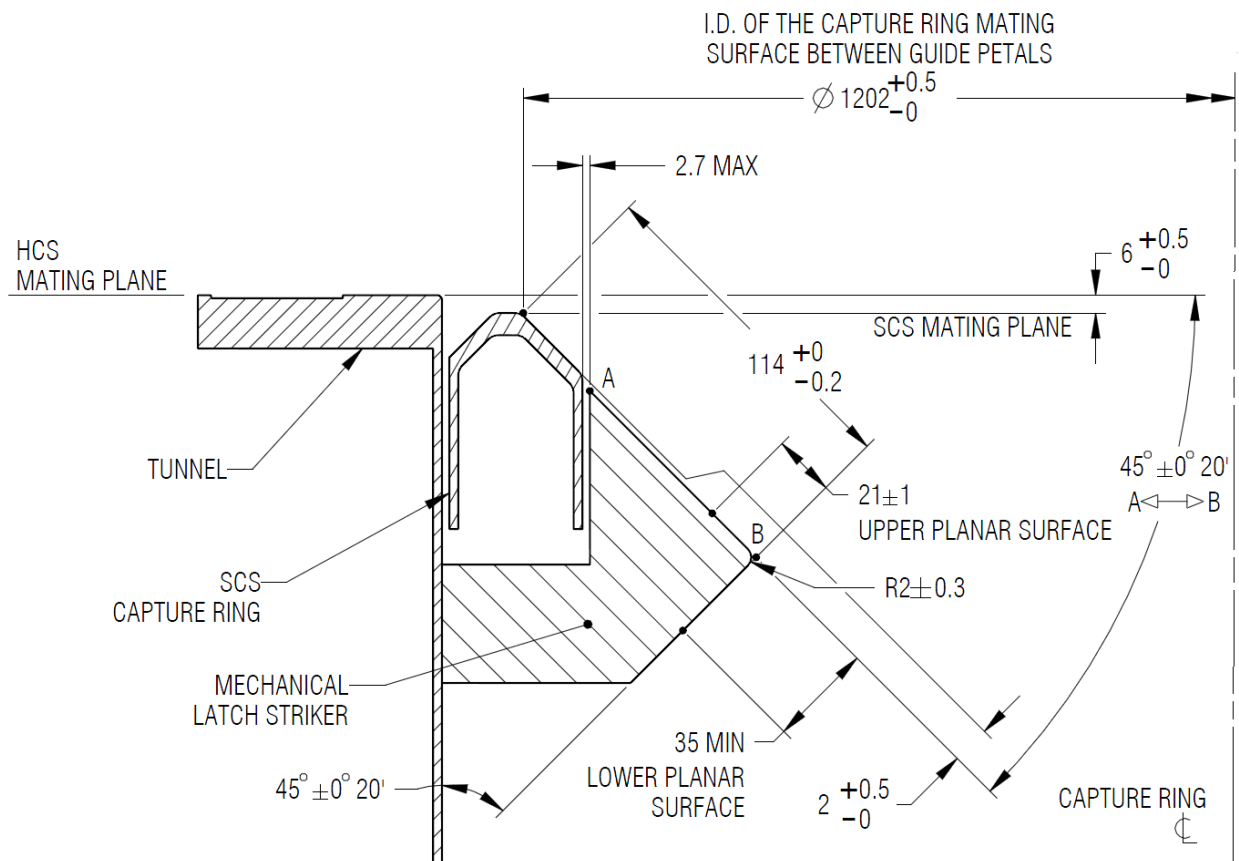
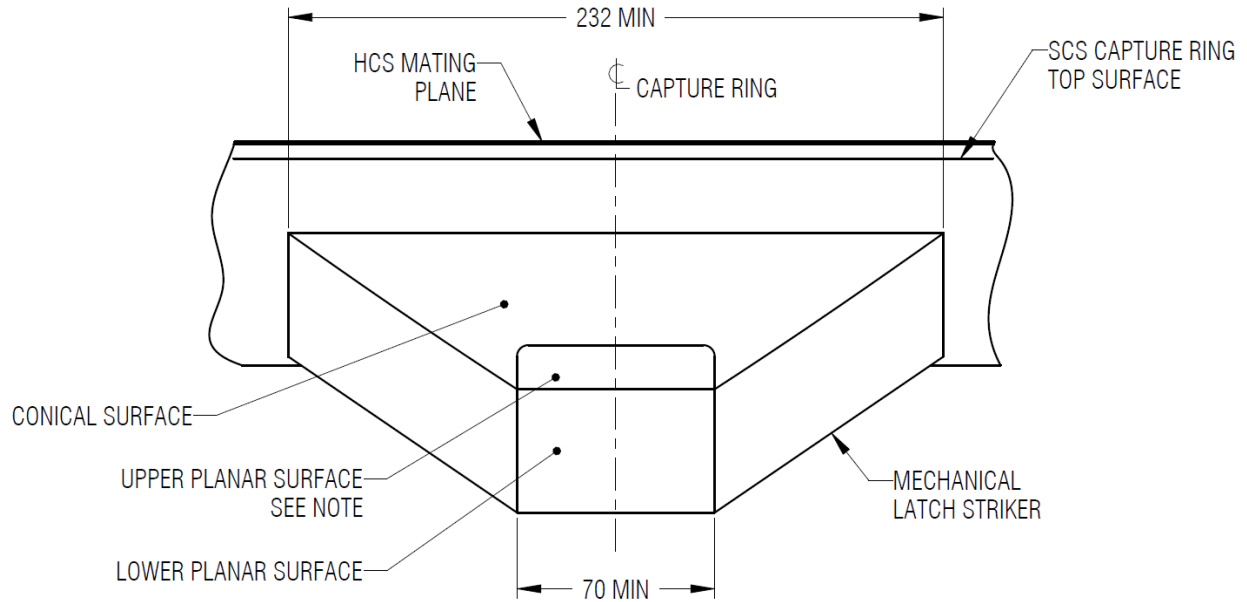

FIGURE 3.2.2.4-1 CROSS SECTIONAL VIEW THROUGH CENTERLINE OF MECHANICAL LATCH STRIKER



Notes:

1. All dimensions are linear dimensions.
2. Two orthogonal planar surfaces are required to form a straight edge at nose. The upper planar surface transitions into the Striker conical surface as required in such a way that the upper planar surface is either flush or slightly recessed below the conical surface. This will ensure there is no obstruction on the striker during SCS capture.

FIGURE 3.2.2.4-2 RADIAL VIEW

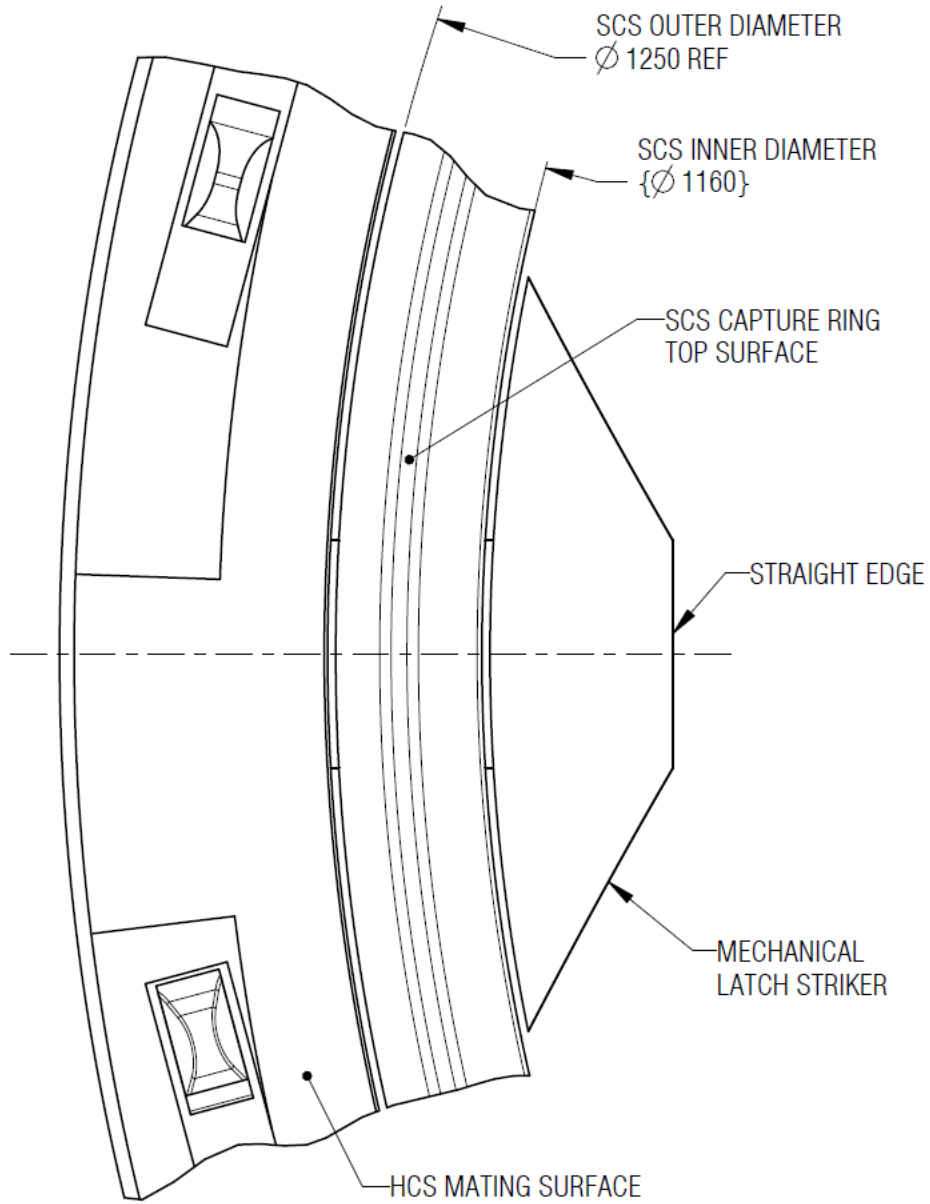
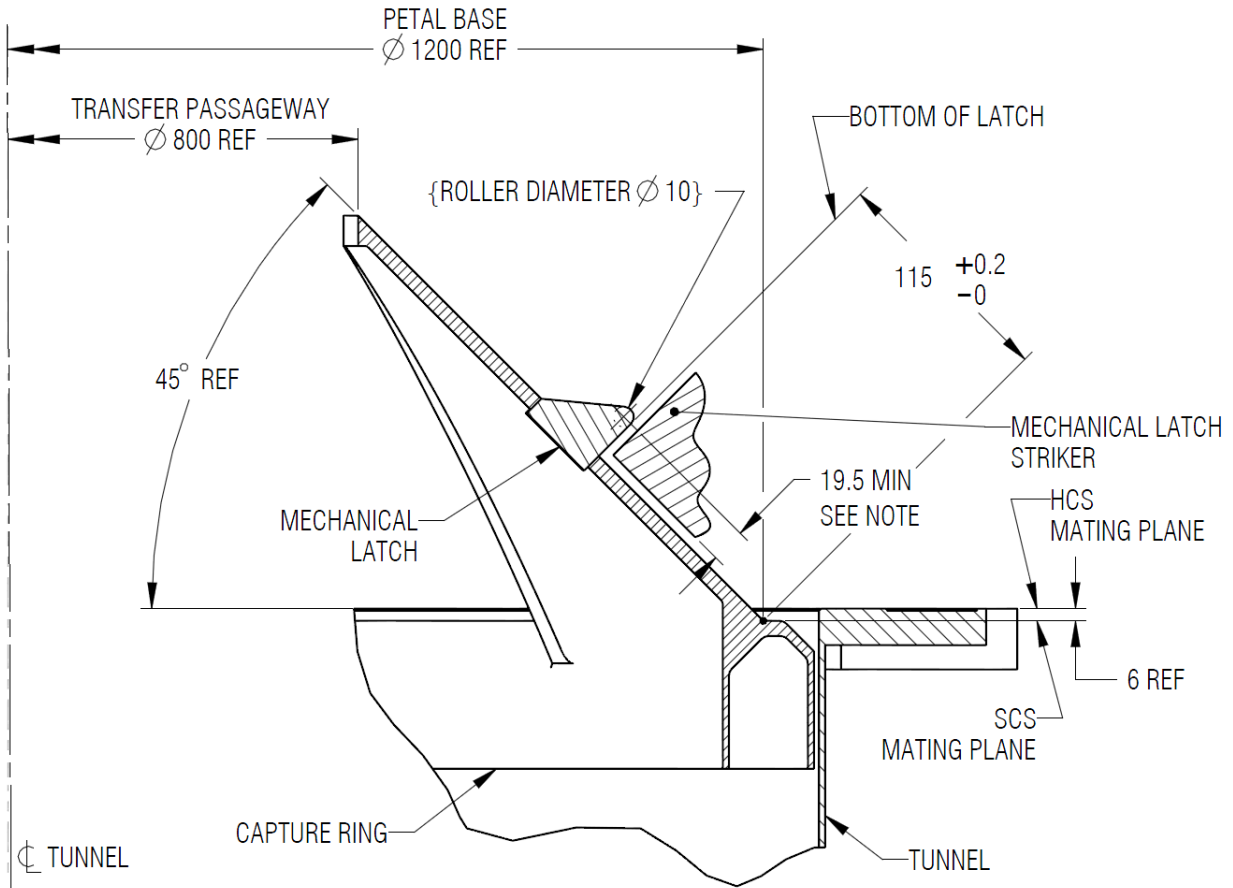

FIGURE 3.2.2.4-3 TOP VIEW



Note: Nominal minimum latch engagement.

FIGURE 3.2.2.4-4 ACTIVE MECHANICAL SOFT CAPTURE LATCH INTERFACE

3.2.2.5 SOFT CAPTURE SENSOR ACTUATION

To ensure successful soft capture performed by various active docking systems that may utilize different technologies, a limit on the total resistance force produced by a passive SCS, including force to simultaneously actuate all SCS sensors (Example: Capture sensors), is to be defined as follows:

The total actuation force due to all SCS sensors shall be $\leq 50\text{N}$.

3.2.2.6 SOFT CAPTURE SENSOR STRIKERS

Designated areas for striker zones used by all SCS sensors from the opposing docking system are defined as shown in Figures 3.2.2-1 and 3.2.2-2. Active system shall place their sensors such that they will strike the passive IDSS interface within these zones. Passive system shall provide a smooth striking surface within these zones to accommodate active system sensors.

3.2.3 HARD-CAPTURE SYSTEM

The Hard Capture System (HCS) performs the final structural mating between the two vehicles, establishing a connection capable of withstanding atmospheric pressure combined with the loads from planned mated operations of the two spacecraft.

The HCS interface shall conform to the definition as shown in Figure 3.2.3-1, HCS Interface – Axial View, and Figure 3.2.3-2, HCS Interface – Sensor Striker Zone. HCS components that are not critical for transferring mated loads or maintaining pressurization are intentionally omitted from these figures for clarity. Designated striker regions are identified for participants to configure peripheral hardware (e.g. separation system and sensors).

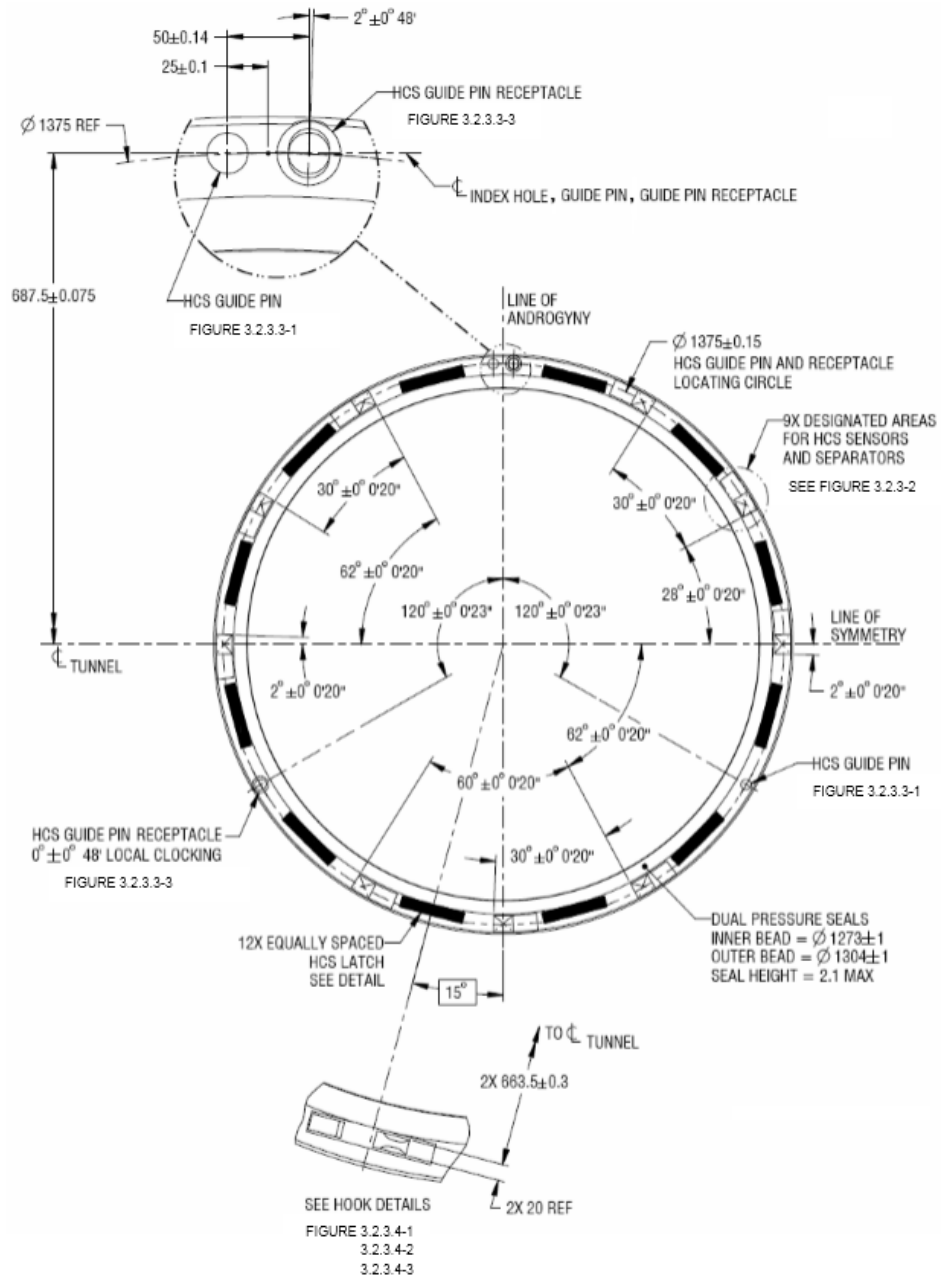

Notes:

1. Boxed angular dimensions are shown as Basic Dimensions that illustrate the theoretical construction lines.
 No dimensional tolerances are to be applied to the Basic Dimensions.
2. Separation systems shall be retracted below the HCS mating plane prior to closure of HCS interface.

FIGURE 3.2.3-1 HCS INTERFACE - AXIAL VIEW

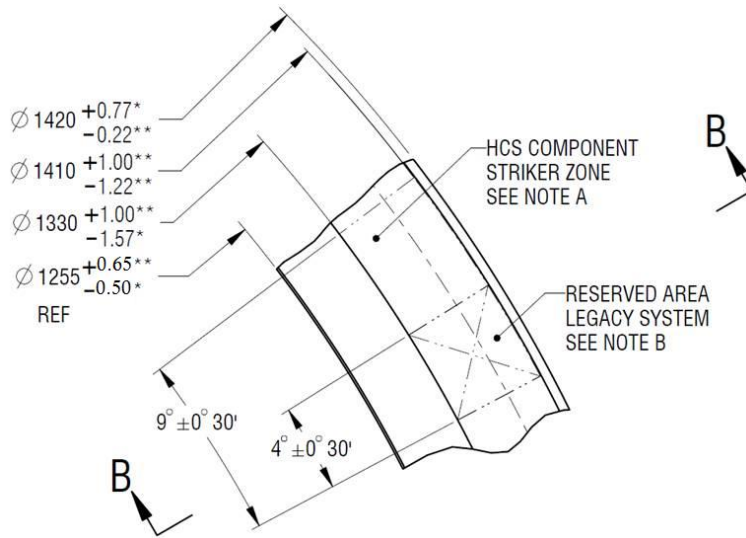

Sensor Striker Zone

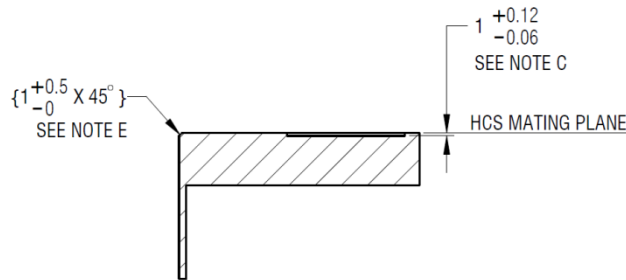

Section B-B

Notes:

* To accommodate NDS legacy

** To accommodate APAS legacy

- “HCS Component Striker Zone” is to depict the area for any international partner’s components to strike. This zone provides the area for HCS sensors and separation mechanisms to contact.
- “Reserved Area” is the area inside the “HCS Component Striker Zone” for legacy HCS components and strikers. Refer to Appendix D for details.
- “HCS Component Striker Zone” and “Reserved Area” are recessed from HCS mating plane as shown in Section B-B.
- HCS Component Striker Zone may contain features that require accommodation. See Appendix D for details.
- A chamfer is shown as a required minimum clearance cutout all around the circumference. The cutout may have a different form and size as long as it meets the above minimum material removal requirement.

FIGURE 3.2.3-2 HCS INTERFACE - SENSOR STRIKER ZONE

3.2.3.1 TUNNEL

The tunnel is the main housing of the docking system that includes the interface flange for structural mating.

3.2.3.2 SEAL

The HCS shall implement two concentric pressure seals that accommodate seal-on-seal mating. For seal diametral dimensions, refer to Figure 3.2.3-1. The pressure seals are located internally with respect to the tangential hook location. Seal parameters shall be as defined below. Also see Table 3.3.2.1-1, Maximum Mated Loads, for seal closure (compression) force.

Total seal adhesion force for both concentric seals ≤ 900 N

Seal protrusion height in a free state above the HCS mating plane ≤ 2.1 mm

“Seal adhesion force” is defined as the force that is required to pull the docking pressure seals apart after they have been pressed together.

3.2.3.3 GUIDE PINS AND RECEPTACLES

The HCS shall implement two guide pins and two guide pin receptacles, as shown in the Guide Pin Details [Figures 3.2.3.3-1, Guide Pin, and 3.2.3.3-2, Section C-C] and the Guide Pin Receptacle Details [Figures 3.2.3.3-3, Guide Pin Receptacle, and 3.2.3.3-4, Section D-D] for final alignment features of the hard-mate interface. The dimensions shown are for the final interface contour surfaces of the docking system assembly, disregarding any specific design of the insert.

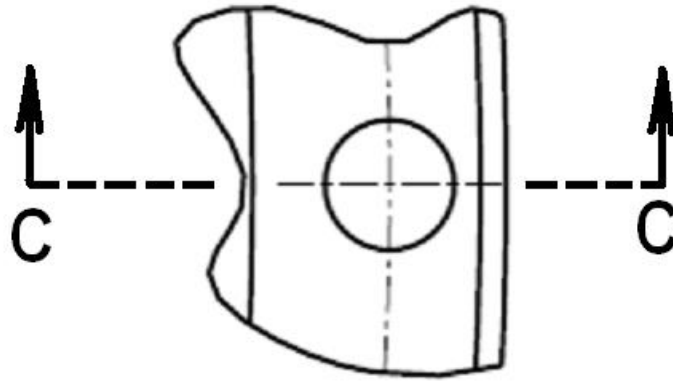

FIGURE 3.2.3.3-1 GUIDE PIN

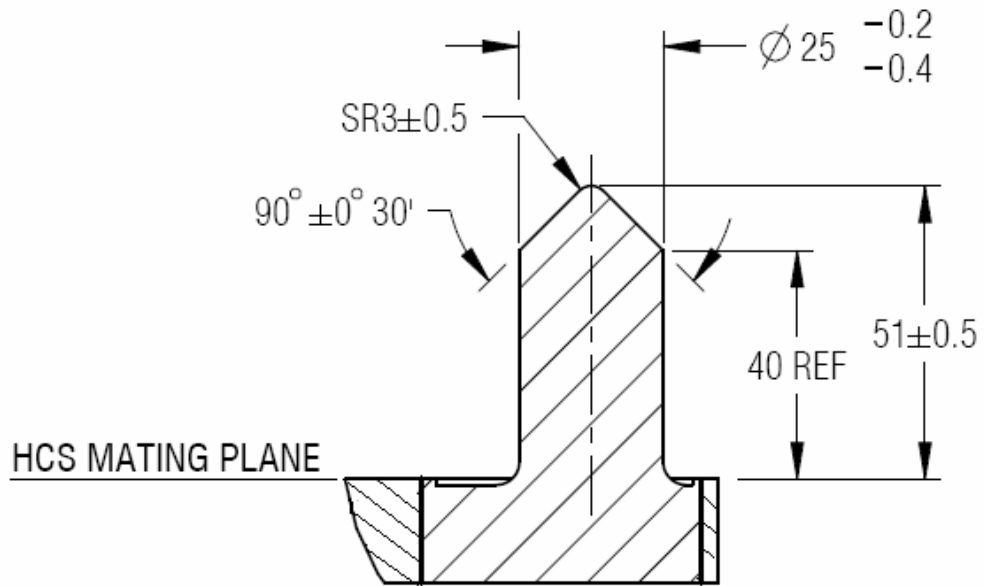

FIGURE 3.2.3.3-2 SECTION C-C

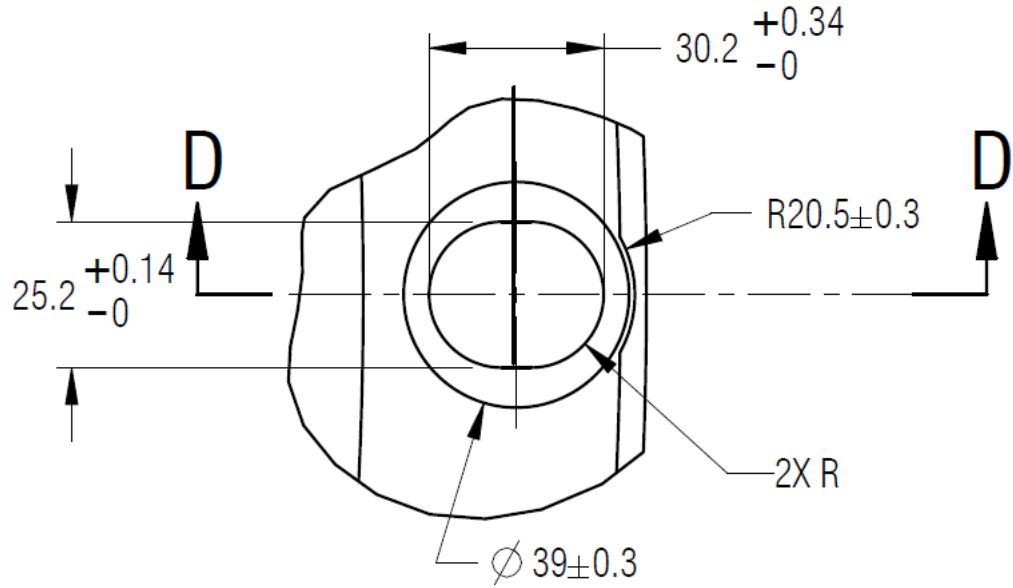
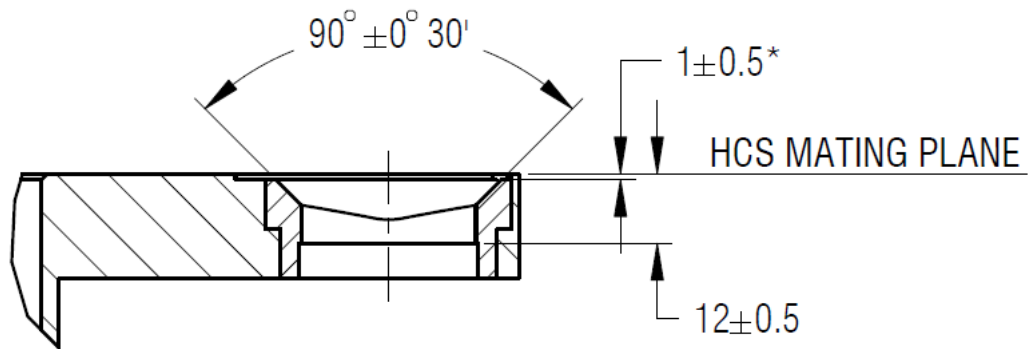

FIGURE 3.2.3.3-3 GUIDE PIN RECEPTACLE



***Note:** As the Guide Pin Receptacle is located in a recessed area, this dimension depicts the distance from the HCS Mating Plane to the start of the hole chamfer.

FIGURE 3.2.3.3-4 SECTION D-D

3.2.3.4 HARD CAPTURE HOOKS

The HCS shall incorporate 12 pairs of active and passive hooks, located as shown in Figure 3.2.3-1. To carry nominal loads, 12 active hooks on one docking system shall engage 12 passive hooks on an opposing docking system interface. On a fully androgynous system, the 12 active hooks on each side of the interface may be engaged with the 12 passive hooks on the opposing interface for a total of 24 active hook engagements. Although engaging 24 hooks is not a requirement, this capability can be used to carry additional mated interface loads. The HCS implements a passively compliant passive hook. The hooks shall conform to the definition as shown in the HCS Hooks – Side Views [Figures 3.2.3.4-1, Ready to Dock Configuration, 3.2.3.4-2, Ready to Hook Configuration, and 3.2.3.4-3, Fully Mated Configuration], Figure 3.2.3.4-4, HCS Active Hook, and the HCS Passive Hook [Figures 3.2.3.4-5, Passive Hook, and 3.2.3.4-6, Passive Hook Detail View]. The motion of the active hook shall be bounded by the envelope shown in Figure 3.2.3.4-7, HCS Active Hook Motion Envelope.

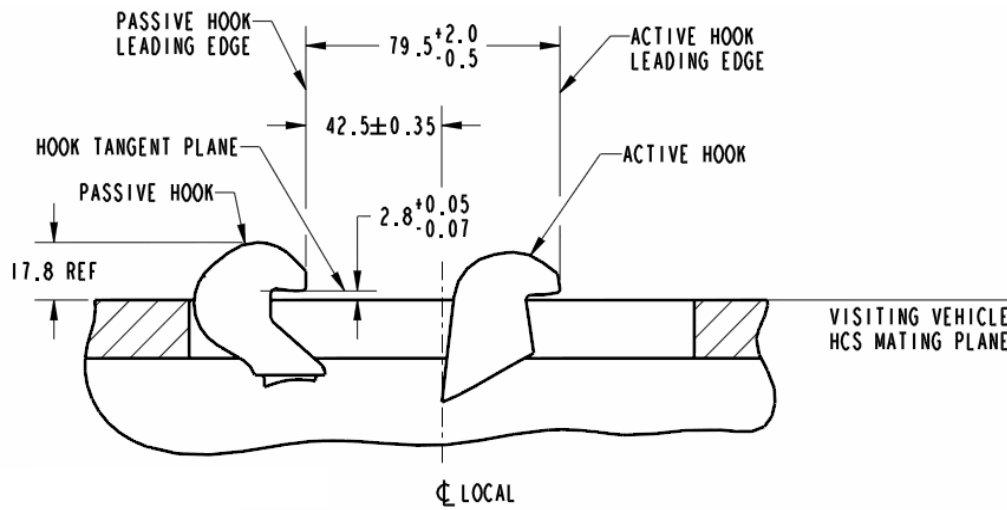

FIGURE 3.2.3.4-1 READY TO DOCK CONFIGURATION

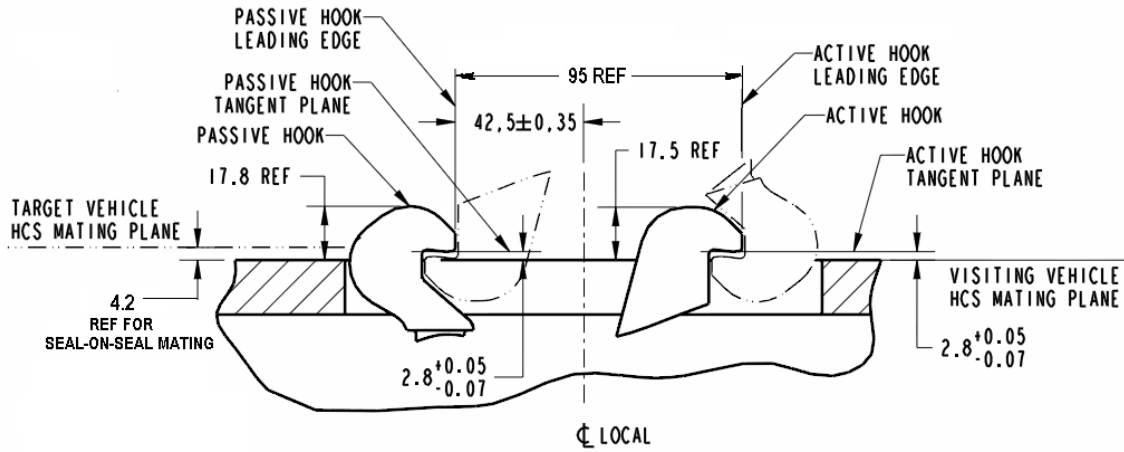

FIGURE 3.2.3.4-2 READY TO HOOK CONFIGURATION

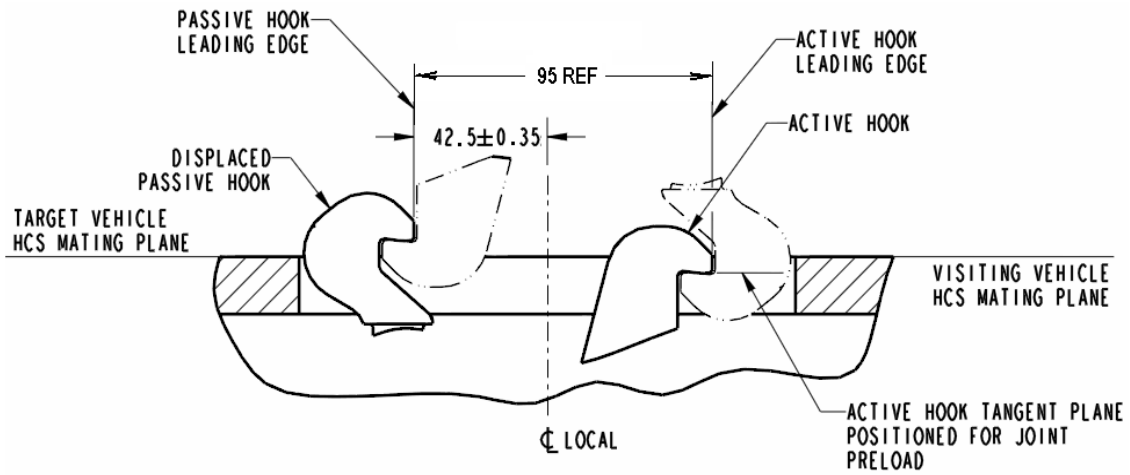

FIGURE 3.2.3.4-3 FULLY MATED CONFIGURATION

IDSS IDD Revision D
April 30, 2015

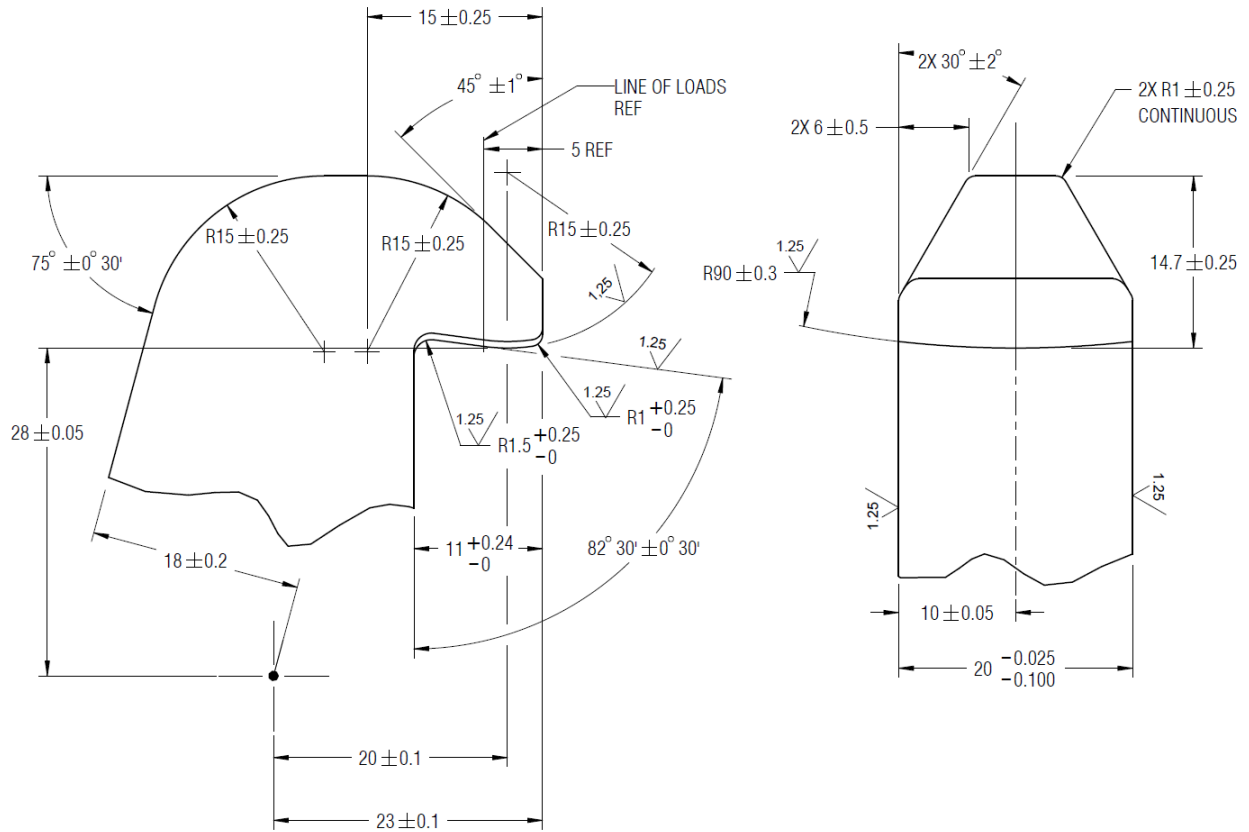

FIGURE 3.2.3.4-4 HCS ACTIVE HOOK

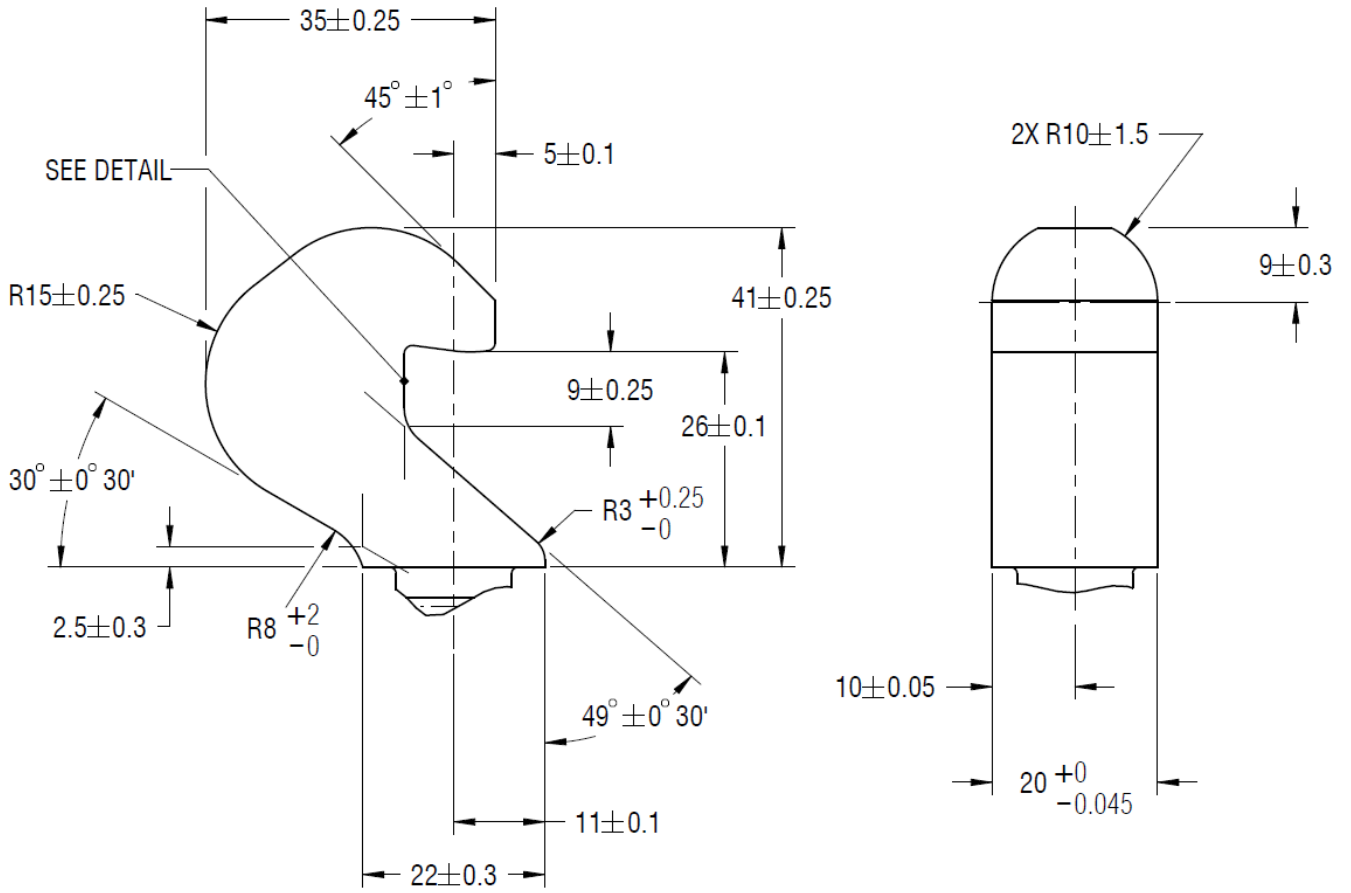

FIGURE 3.2.3.4-5 PASSIVE HOOK

IDSS IDD Revision D
April 30, 2015

The Hook System is defined as the serial combination of the Active Hook Mechanism, Passive Hook Mechanism and the structural elements that are in compression.

A. The Preload of the Hook System after locking shall be between the following values:

Minimum Preload of Hook System after locking = 31 300 N

Maximum Preload of Hook System after locking = 44 340 N

B. The Design Limit Capability of the Active and Passive Hook element shall be = 50 000 N

C. The load response (stiffness) of the Active Hard Capture Hook Mechanism shall be between the upper and lower curves as defined Figure 3.2.3.4-8, Load Response of Active Hook Mechanism.

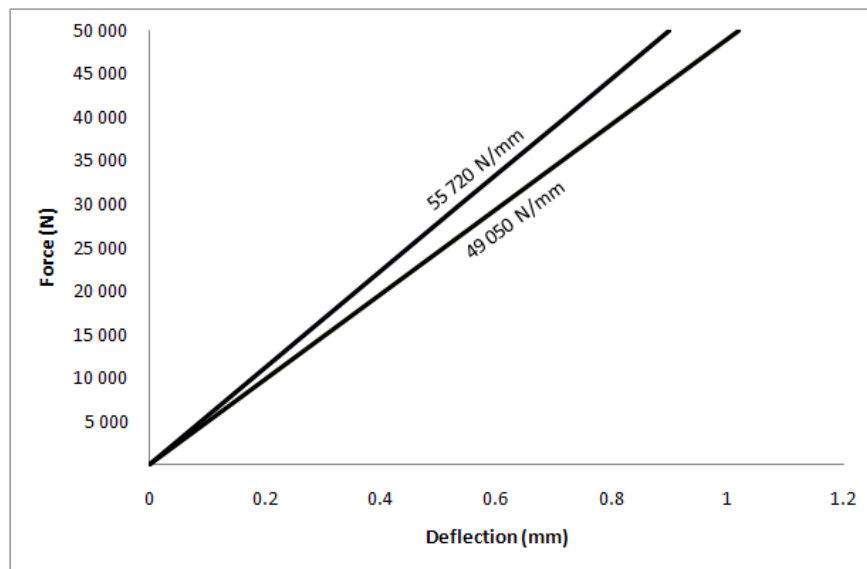

FIGURE 3.2.3.4-8 LOAD RESPONSE OF ACTIVE HOOK MECHANISM

D. The load response (stiffness) of the Passive Hard Capture Hook Mechanism shall be between the upper and lower curves as defined in Figure 3.2.3.4-9, Load Response of Passive Hook Mechanism (including Spring Washer Stack).

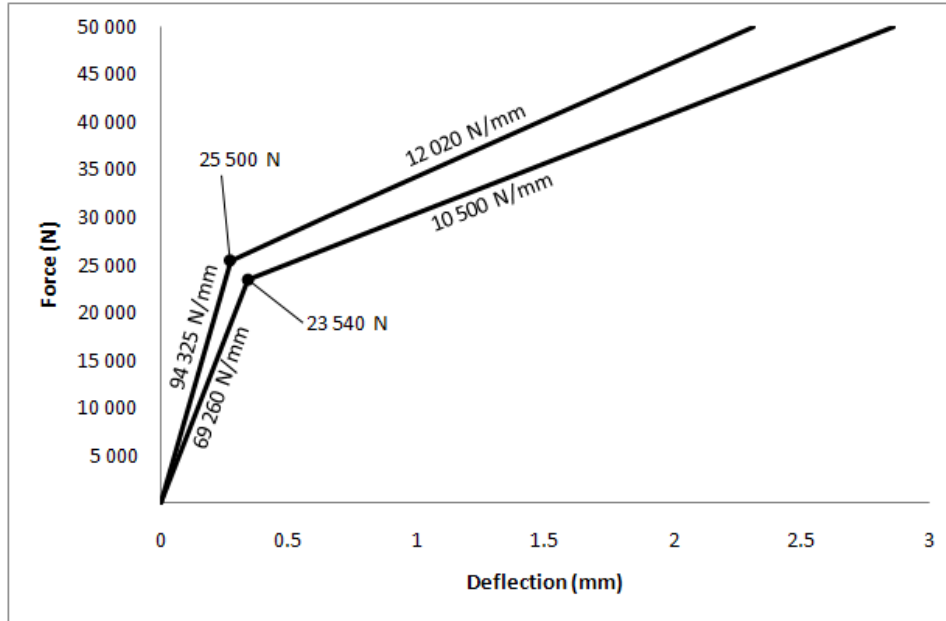

FIGURE 3.2.3.4-9 LOAD RESPONSE OF PASSIVE HOOK MECHANISM (INCLUDING SPRING WASHER STACK)

3.2.3.5 HARD CAPTURE STRIKER AREAS

The HCS has designated areas for striker zones used by the opposing docking system. These striker areas can be used for various HCS sensory components or other subsystems such as separation system push-off devices. IDSS compliant systems shall abide by the designated striker zones defined in Figure 3.2.3-1 and Figure 3.2.3-2.

3.2.3.6 SEPARATION SYSTEM - GENERAL

IDSS compliant systems shall implement a retractable separation system that can be remotely commanded to fully retract below the interface plane without application of external forces. The separation system shall provide a symmetric undocking separation force. The number of separators is a choice left to the docking system designer, provided that they comply with the Hard Capture Striker designated areas (see 3.2.3.5).

3.2.3.6.1 SEPARATION SYSTEM – FORCE LIMITS

- A. Total separation force shall be < 2670 N when the HCS interface is fully mated.
- B. Total separation force shall be ≥ 1778 N at 4.2 mm above the HCS Mating Plane.

3.2.3.6.2 SEPARATION SYSTEM – ENERGY

Total energy available from the separation system shall be between 39.2 N-m and 47.5 N-m when the HCS interface is fully mated.

3.2.3.7 HCS COMPRESSIVE FORCE RESISTANCE DURING SCS RETRACTION

During the SCS retraction for hard mate, sensors on the mating HCS mechanisms, such as “Ready-to-Hook” or “Undocking-Complete” indicators, will be compressed. A limit on the total resistance force produced by all sensors on the passive HCS system during SCS retraction is to be defined as follows:

The total resistance force contributed by all HCS sensors on the passive side shall be ≤ 85 N at a separation of ≥ 4.2 mm between the HCS Mating Planes.

3.2.4 ELECTRICAL BONDING

3.2.4.1 SOFT CAPTURE SYSTEM

IDSS compliant systems shall establish bond paths to mitigate electrical hazards on the integrated subsystem interfaces.

IDSS compliant mechanisms protect against electrostatic discharge through the soft capture system. The bond path may be through any metal to metal contact provisions for this purpose. The requirement is from initial contact to hard capture during the docking operation.

Bonding resistance for the SCS after soft capture shall be 1 ohm or less TBC.

<TBC 3-1>

3.2.4.2 HARD CAPTURE SYSTEM

IDSS compliant mechanisms are to be protected against RF emissions. The bond path is through metal to metal contact on the seal interface between two IDSS compliant HCS mechanisms.

Bonding resistance for the HCS after latching shall be 2.5 milliohms or less.

3.2.5 ENVIRONMENTS

Materials used in the construction of the docking interface shall allow proper mating while experiencing the following conditions:

- A. Temperature difference between the two mating interfaces of up to 55°C
- B. External pressure environment $< 1.0 \times 10^{-4}$ Pa

3.2.6 MATERIALS AND SURFACE FINISHES

In general, the interface features defined herein, except for the pressure seals, should have stiffness and hardness comparable to that of metal alloys commonly used in aerospace vehicle primary structures, and which do not significantly impede relative motion. Interface surfaces which slide against each other to assist in docking interface alignment should incorporate a surface coating or finish that has low friction characteristics. The resultant coefficient of friction between two mating systems is an integrated performance characteristic which affects soft capture success.

Specific material selection for the pressure seals will be at the designer's discretion.

3.3 DOCKING PERFORMANCE

In addition to the physical geometric interface requirements, a set of common design parameters enveloping the reference missions and conditions is provided. For the SCS, this set includes interface loads, vehicle mass properties, and initial contact conditions. For the HCS, this set includes mated loads. Of these common design parameters, only the loads have been defined as requirements. The other common design parameters, if accommodated in the docking system design, increase the probability of successful docking between different spacecraft.

3.3.1 SOFT CAPTURE SYSTEM

The SCS docking performance is defined by the mechanism's ability to capture and attenuate. During the capture phase, the mechanism is contending with the spacecraft misalignment to achieve capture. During the attenuation phase, the mechanism is limiting the relative motion and limiting the loads.

3.3.1.1 INITIAL CONTACT CONDITIONS AND COORDINATE SYSTEMS

Initial contact conditions are instantaneous relative states of the active docking interface with respect to the passive docking interface at docking interface first contact (first physical touch). They are used to define the lateral and angular misalignment, and translational and angular velocity errors when compared to perfect alignment and zero relative velocity at the docking interfaces.

The coordinate systems of docking units and docking objects are used to define the motion during docking and Initial Contact Conditions. An overview and description of coordinate systems is provided in Table 3.3.1.1-1, Coordinate Systems Used for Docking Motion Description. Figures 3.3.1.1-1 and 3.3.1.1-2 define the coordinate systems of the Docking system and the Docking objects.

The axes of the motion coordinate systems of active and passive objects correspond to ISO 5843-4: 1990 Definition, i.e.

- A. Pitch – pitch angle θ_Y is defined positive about +Y-axis, using right-handed rule;
- B. Yaw – yaw angle Ψ_Z is defined positive about +Z-axis, using right-handed rule;
- C. Roll – roll angle ϕ_X is defined positive about +X-axis, using right-handed rule;

To increase the probability of successful docking between different spacecraft, it is recommended that IDSS-compliant mechanisms capture and attenuate vehicles within initial contact conditions shown in Table 3.3.1.1-2, Initial Contact Conditions.

The set of limiting initial contact conditions provided in Table 3.3.1.1-2 represents the values used in the derivation of the loads defined in Table 3.3.1.4-1, SCS Maximum Interface Loads, and Table 3.3.1.4-2, SCS Maximum Component Loads, and

represents the achievable capture envelope provided by IDSS-compatible mechanism's passive interface.

TABLE 3.3.1.1-1 COORDINATE SYSTEMS USED FOR DOCKING MOTION DESCRIPTION

#	Name	Symbol	Position	Orientation	Purpose
1. Coordinate systems of docking system interfaces					
1.1	Active SCS ring coordinate system	$X_{AR}Y_{AR}Z_{AR}$	Active ring center	+ X_{AR} : closing direction, + Y_{AR} : line of symmetry, through petal number 3 + Z_{AR} : make right coordinate system, (see Figure 3.3.1.1-2)	<ul style="list-style-type: none"> • Docking mechanism motion description • Description of ring contact interaction
1.2	Passive SCS ring coordinate system	$X_{PR}Y_{PR}Z_{PR}$	Passive ring center	$X_{PR}Y_{PR}Z_{PR}$ – according to $X_{AR}Y_{AR}Z_{AR}$	<ul style="list-style-type: none"> • Description of ring contact interaction
1.3	Coordinate system of initial position of active docking mechanism	$X_{AI}Y_{AI}Z_{AI}$	Active ring center before first contact	+ X_{AI} : closing direction, + Y_{AI} : line of symmetry, through petal number 3 + Z_{AI} : make right coordinate system, (see Figure 3.3.1.1-1)	<ul style="list-style-type: none"> • Description of initial position for docking
1.4	Coordinate system of active docking mechanism base	$X_{AB}Y_{AB}Z_{AB}$	Center of active docking mechanism base	$X_{AB}Y_{AB}Z_{AB}$ – according to $X_{AD}Y_{AD}Z_{AD}$, (see Figure 3.3.1.1-1)	<ul style="list-style-type: none"> • Docking mechanism motion description
1.5	Coordinate system of active docking/HCS mating plane	$X_{AD}Y_{AD}Z_{AD}$	Center of active docking plane	+ X_{AD} : closing direction, + Y_{AD} : line of symmetry, through petal number 3 + Z_{AD} : make right coordinate system, (see Figure 3.3.1.1-1)	<ul style="list-style-type: none"> • Docking mechanism movement description relative to active docking/HCS mating plane • Contact interaction analysis of HCS elements
1.6	Coordinate system of passive docking/HCS mating plane	$X_{PD}Y_{PD}Z_{PD}$	Center of passive docking plane	$X_{PD}Y_{PD}Z_{PD}$ – according to $X_{AD}Y_{AD}Z_{AD}$	
2. Coordinate systems of docking objects					
2.1	Motion coordinate system of active object (1)	$X_1Y_1Z_1$	At the active object CG	+ X_1 : closing direction, + Y_1 : according to + Y_{AD} + Z_1 : make right coordinate system, (see Figure 3.3.1.1-1 and Figure 3.3.1.1-2)	<ul style="list-style-type: none"> • Objects motion description relative to inertial coordinate system • Active object motion description relative to passive object
2.2	Motion coordinate system of passive object (2)	$X_2Y_2Z_2$	At the passive object CG	$X_2Y_2Z_2$ – according $X_1Y_1Z_1$ by zero mis-alignments	

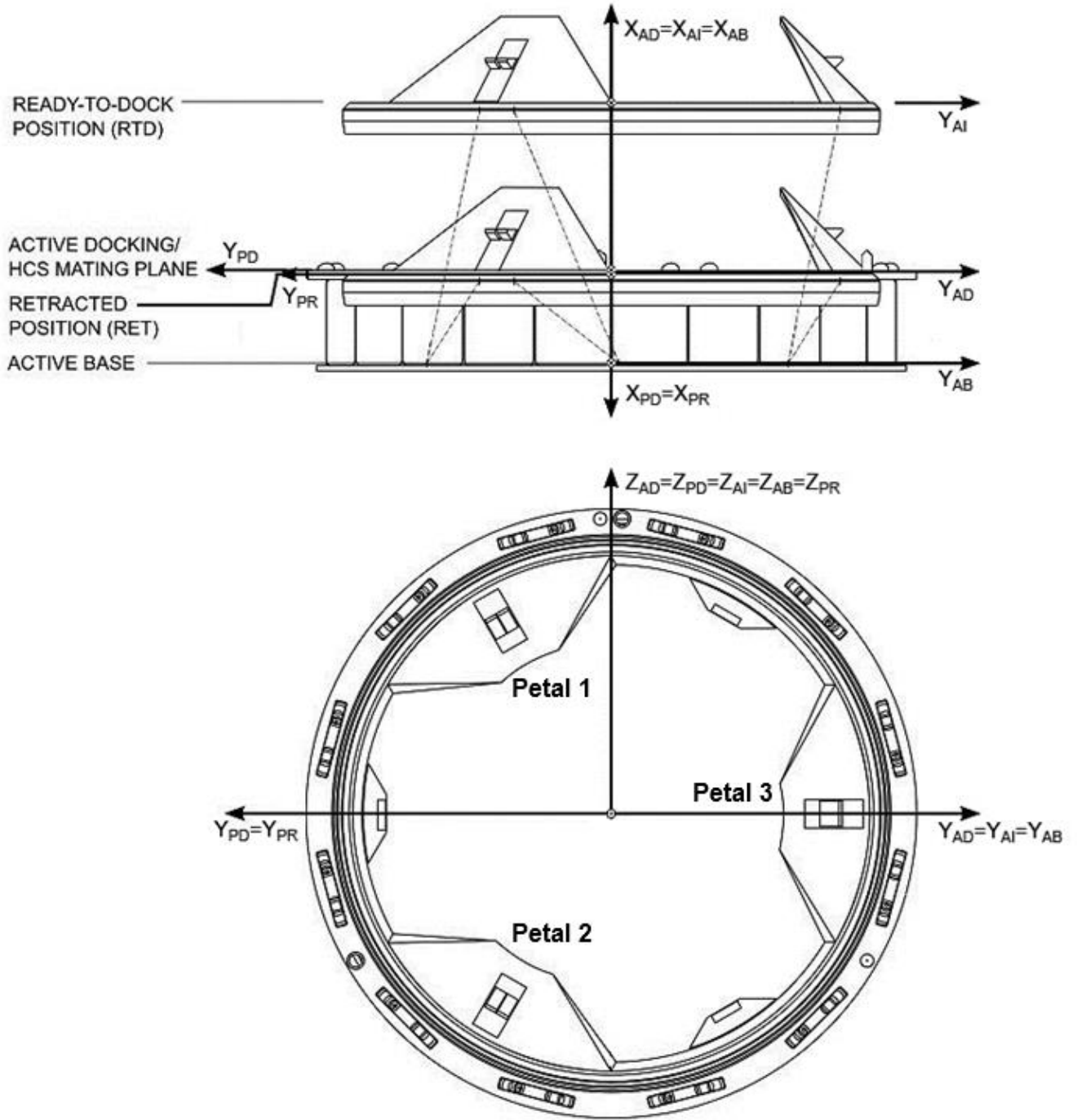

FIGURE 3.3.1.1-1 COORDINATE SYSTEMS OF DOCKING SYSTEM

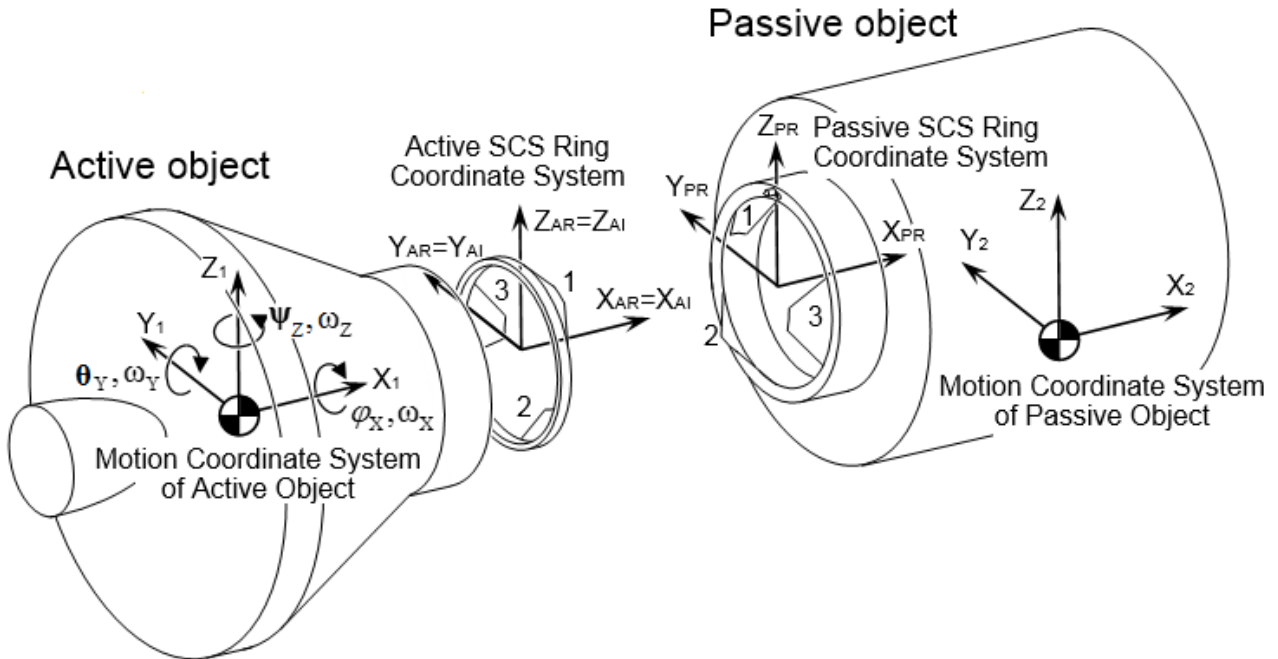

FIGURE 3.3.1.1-2 COORDINATE SYSTEM OF DOCKING OBJECTS (ACTIVE AND PASSIVE)

TABLE 3.3.1.1-2 INITIAL CONTACT CONDITIONS

Initial Condition	Limiting Value
Closing (axial) rate	0.05 to 0.10 m/sec
Lateral (radial) rate	0.04 m/sec
Pitch/Yaw rate	0.20 deg/sec (vector sum of pitch/yaw rate)
Roll rate	0.20 deg/sec
Lateral (radial) misalignment	0.10 m
Pitch/Yaw misalignment	4.0 deg (vector sum of pitch/yaw)
Roll Misalignment	4.0 deg

Notes:

1. Initial contact conditions are independent and are to be applied simultaneously, with the exception that the lateral rate at the vehicle cg resulting from the combination of lateral (radial) rate and the pitch/yaw angular rate should not exceed the lateral (radial) rate limit.
2. Mean closing (axial) rate may be adjusted depending on vehicle mass combinations. Refer to Table 3.3.1.2-1.
3. Post contact thrust may be used to achieve necessary capture performance.
4. Lateral (radial) misalignment is defined as the minimum distance between the center of the active soft capture ring and the longitudinal axis of the passive soft capture ring at the moment of first contact between the guide petals.

3.3.1.2 VEHICLE MASS PROPERTIES

To increase the probability of successful docking between different spacecraft, it is recommended that IDSS-compliant mechanisms capture and attenuate vehicles with the mass properties shown in Table 3.3.1.2-1, Vehicle Mass Properties. The set of design case vehicle mass properties provided in Table 3.3.1.2-1 represents the values used in the derivation of the loads defined in Table 3.3.1.4-1 and Table 3.3.1.4-2.

TABLE 3.3.1.2-1 VEHICLE MASS PROPERTIES

Article	Mass (kg)	Moment of Inertia (kg*m ²)						Coordinates of the Hard Capture System Mating Plane Center (m)		
		I _{xx}	I _{yy}	I _{zz}	I _{xy}	I _{xz}	I _{yz}	X	Y	Z
IDSS-350T	3.50E+5	1.15E+8	6.20E+7	1.65E+8	-2.30E+6	-5.00E+5	-4.60E+5	20.0	0	2
IDSS-25T	25 000	70 000	169 000	169 000	0	0	0	5.4	0	0
IDSS-20T	20 000	55 000	135 000	135 000	0	0	0	4.3	0	0
IDSS-15T	15 000	41 000	71 000	71 000	0	0	0	4.1	0	0
IDSS-10T	10 000	17 000	42 000	42 000	0	0	0	3.5	0	0
IDSS-5T	5 000	3 400	18 000	18 000	0	0	0	2.3	0	0

Notes:

1. Moments of inertia (MOI) are about center of gravity (CG) and products of inertia (POI) are positive integral.
2. Mass properties defined in coordinate system located at CG with X-axis along vehicle longitudinal axis and positive toward the docking interface.

3.3.1.3 VEHICLE MOTION LIMITS

Reserved.

TABLE 3.3.1.3-1 VEHICLE MOTION LIMITS

Reserved.

3.3.1.4 LOADS

The active SCS of IDSS-compliant mechanisms shall meet all of its functional and performance requirements without exceeding the loads defined in Table 3.3.1.4-1 and Table 3.3.1.4-2.

TABLE 3.3.1.4-1 SCS MAXIMUM INTERFACE LOADS

Load	Limiting Value
Tension	3 900 N
Compression (Static)	3 500 N
Compression (Dynamic, up to 0.1sec)	6 500 N
Shear	3 200 N
Bending	2 800 N*m
Torsion	1 500 N*m
Notes: 1. Values are design limit loads. 2. Values are defined at the center of the SCS mating plane (Figure 3.1.1.1-1). 3. Values are 3σ maxima and are to be applied simultaneously, not to exceed the component values shown in Table 3.3.1.4-2. 4. Shear loads may be applied in any direction in the SCS mating plane. 5. Bending moment may be applied about any axis in the SCS mating plane.	

TABLE 3.3.1.4-2 SCS MAXIMUM COMPONENT LOADS

Load	Limiting Value			
Mechanical Latch Striker Tension	3 000 N			
Magnetic Latch Striker Tension	2 300 N			
Striker (Ring to Ring) Compression	3 000 N			
Petal Edge Length	0%	10%	60%	80%
Petal Contact Loads	3 500 N	2 300 N	2 300 N	1 000 N
Notes: 1. Values are design limit loads. 2. The petal contact load is to be applied to the petal edge from the root of the petal to 80% of the petal length. 3. The petal contact load is to be applied to the outer face of the petal from the root of the petal to 60% of the petal length.				

3.3.2 HARD CAPTURE SYSTEM

3.3.2.1 MATED LOADS

IDSS-compliant mechanisms shall certify to the loads shown in Table 3.3.2.1-1, HCS Maximum Mated Loads, and Table 3.3.2.1-2, HCS Mated Load Sets, for design loads,

as a minimum. These loads are applied at the center of the HCS interface, as defined in Figure 3.2.3-1.

TABLE 3.3.2.1-1 HCS MAXIMUM MATED LOADS

Load Set	Mated ISS	Trans-Lunar
Maximum Design Pressure	1 100 hPa	0 h Pa
Seal Closure Force	97 150 N	97 150 N
Compressive Axial Load	17 700 N	300 000 N
Tensile Axial Load	17 700 N	100 000 N
Shear Load	16 700 N	10 000 N
Torsion Moment	15 000 Nm	15 000 Nm
Bending Moment	68 700 Nm	40 000 Nm

TABLE 3.3.2.1-2 HCS MATED LOAD SETS

Load Set	Case 1	Case 2	Case 3	Case 4
Design Pressure	1 100 hPa	1 100 hPa	1 100 hPa	0 hPa
Seal Closure Force	97 150 N	97 150 N	97 150 N	97 150 N
Compressive Axial	5 000 N	17 700 N	13 700 N	300 000 N
Tensile Axial Load	5 000 N	17 700 N	13 700 N	100 000 N
Shear Load	5 000 N	14 800 N	16 700 N	10 000 N
Torsion Moment	15 000 Nm	15 000 Nm	15 000 Nm	15 000 Nm
Bending Moment	65 300 Nm	39 200 Nm	68 700 Nm	40 000 Nm

Notes: (for Table 3.3.2.1-1 and Table 3.3.2.1-2)

- a) Values are design limit loads.
- b) Hard capture hook preload and tunnel stiffness will be such that, when under external loading within limits, there remains metal-to-metal contact in the local vicinity of the hooks.
- c) Shear loads may be applied in any direction in the HCS mating plane.
- d) Bending moment may be applied about any axis in the HCS mating plane.
- e) The outer seal bead is to be used for all pressure calculations.
- f) Load cases are defined in Table 3.3.2.1-2 and Table 3.2.2.1-1 is a summary of the maximum loads.
- g) Case descriptions:
 Case 1 – Attitude control by Orbiter-sized vehicle, combined with crew activity.
 Case 2 – Interface loads due to ISS segment berthing.
 Case 3 – Orbiter-sized vehicle translation with payload attached to ODS.
 Case 4 – Unpressurized high axial tension load case; modified from Constellation Trans-lunar Injection loads analysis.

3.4 RESOURCE TRANSFER UMBILICALS

The IDSS umbilical connectors transfer resources between two docked vehicles. Currently, connectors are only defined to transfer power, data, and a ground safety wire. Future revisions of this IDD may add other resources such as water source and water return capability, fuel, tank pressurization, and oxidizer transfer capability. All umbilical connectors shall be mechanized such that they are recessed below the docking mating plane during docking, and then are driven to mate after docking hard capture occurs. During undocking, the connectors are nominally deactivated and driven to the unmated state prior to unlatching the hooks. Keep Out Zones (KOZ) for legacy, current, and future umbilical hardware, as shown in Figure 3.4-1, Umbilical Connector Keep-Out Zones, shall be honored.

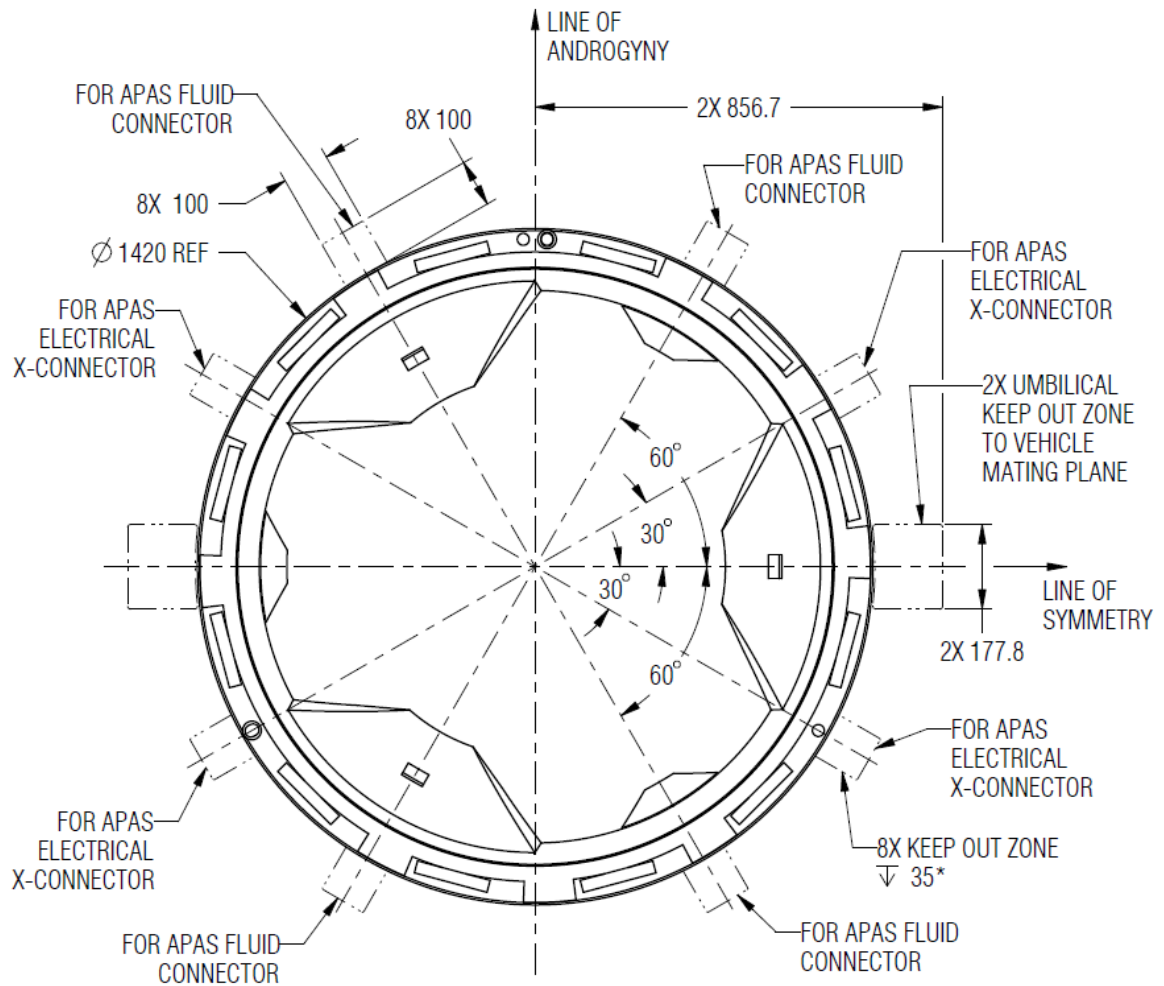

* The KOZ extends 35 mm below the HCS Mating Plane as a minimum. This depth is to accommodate the protrusion of 30mm of connectors on legacy systems.

FIGURE 3.4-1 UMBILICAL CONNECTOR KEEP-OUT ZONES

3.4.1 POWER AND DATA TRANSFER UMBILICAL

The standard Power/Data Transfer Umbilical (PDTU) transfers power and data in the same connector shell. The PDTU function is nominally accomplished using two connector systems for redundancy, and arranged to allow for androgynous operation.

3.4.1.1 FRAM CONNECTOR PART NUMBER

PDTU connectors are to be designed, manufactured, and tested to meet the ISS specification SSQ 22680, Connectors, Rectangular, (ORU), Space Quality, General Specification For, commonly called a Flight Releasable Attachment Mechanism (FRAM)

connector. The FRAM connector part numbers which correspond to this PDTU definition are shown in Table 3.4.1.1-1, FRAM Connector Part Number. IDSS compliant systems shall use connectors that are, as a minimum, compatible with the interface dimensions and interface performance of these part numbers.

TABLE 3.4.1.1-1 FRAM CONNECTOR PART NUMBER

PART NUMBER	DESCRIPTION
SSQ 22680-021	Plug (Pins), FRAM Using Insert Arrangement K
SSQ 22680-022	Receptacle (Sockets), FRAM Using Insert Arrangement K

3.4.1.2 PDTU CONNECTOR OPERATION

The Plug PDTU Connector and Receptacle PDTU Connector (across the docking interface) shall be designed to mate to and demate from the opposing Plug PDTU Connector and Receptacle PDTU Connector as represented in Figure 3.4.1.2-1, PDTU Electro-Mechanical Actuator Concept of Operation.

NOTE: During docking operations, either a Plug PDTU Electro-Mechanical Actuator (EMA) or a Receptacle PDTU EMA is driven to mate the Electrical Resource Connector and trigger the Data Bus Switches.

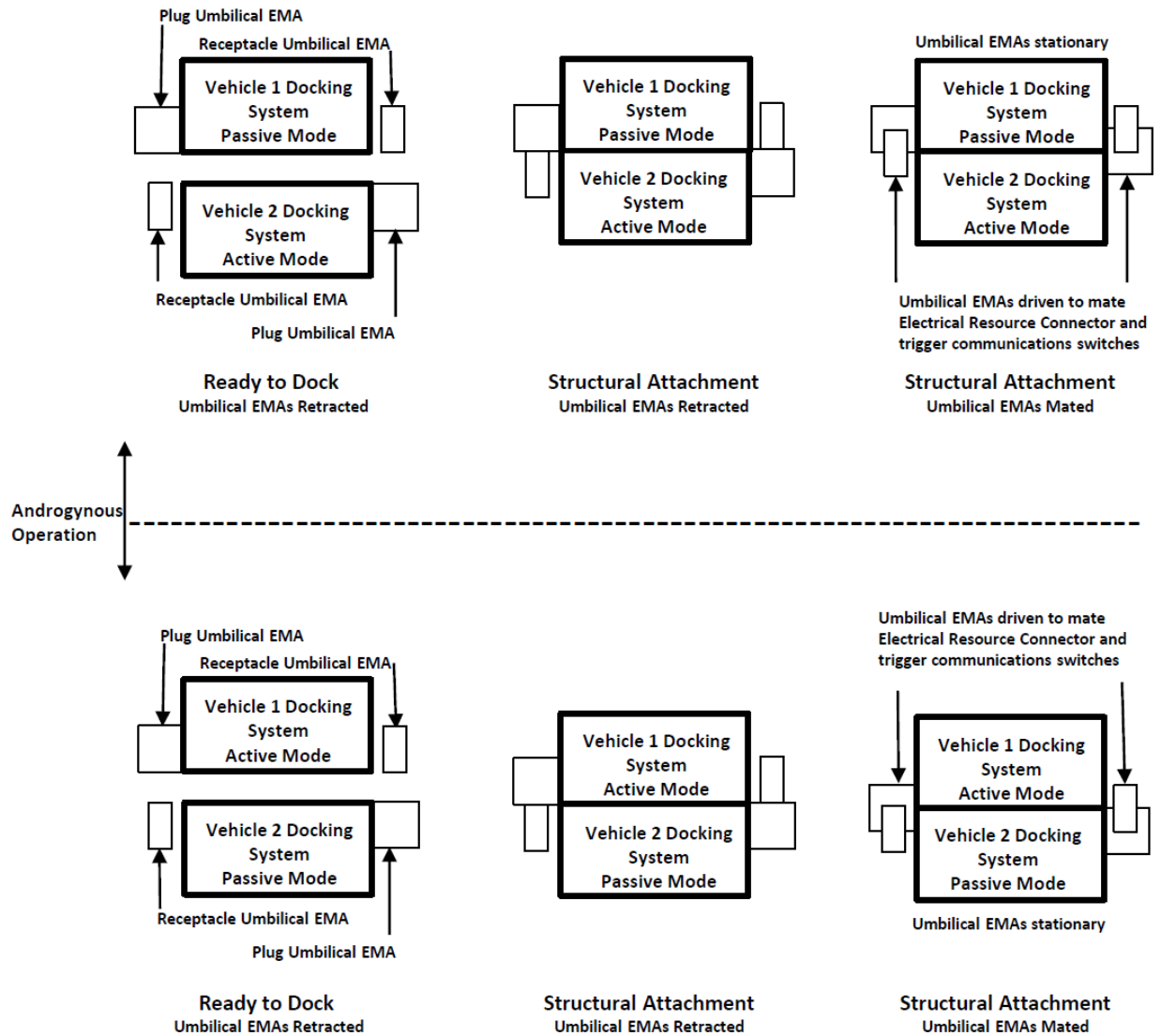

FIGURE 3.4.1.2-1 PDTU ELECTRO-MECHANICAL ACTUATOR CONCEPT OF OPERATION

3.4.1.3 CONNECTOR LOCAL COORDINATE SYSTEM

Each PDTU connector has an individual local coordinate system as represented in Figure 3.4.1.3-1, PDTU Connector Local Coordinate System Definition.

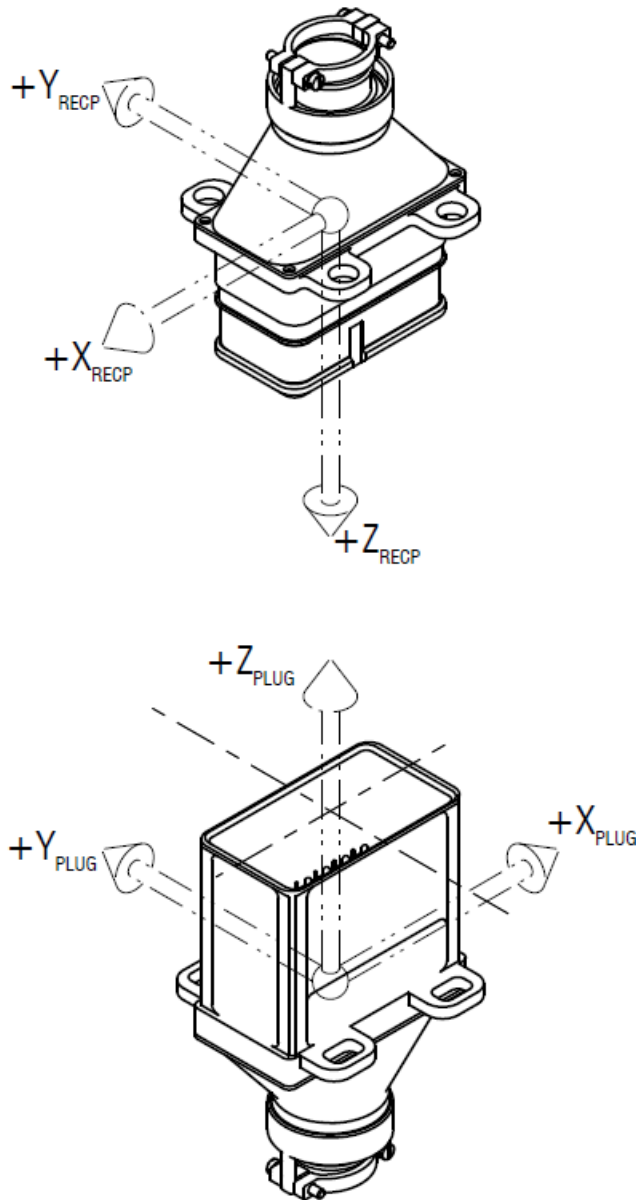
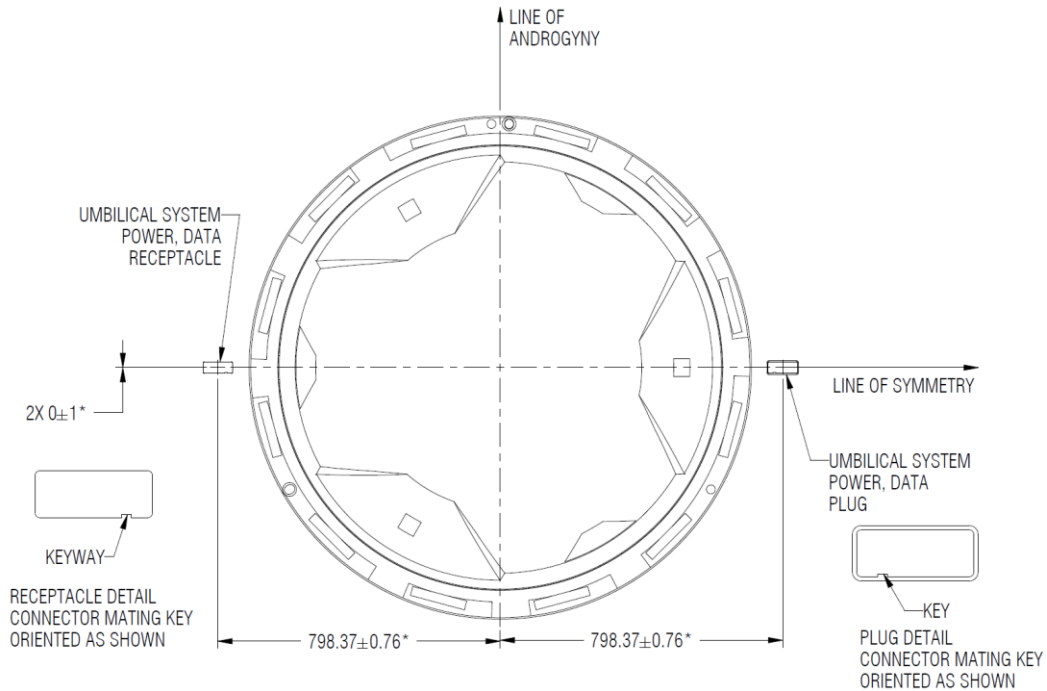

FIGURE 3.4.1.3-1 PDTU CONNECTOR LOCAL COORDINATE SYSTEM DEFINITION

3.4.1.4 LOCATING REQUIREMENTS

3.4.1.4.1 LATERAL MOUNTING REQUIREMENTS

Docking systems which implement the standard PDTU function shall locate two PDTU connectors, one receptacle and one plug, as shown in Figure 3.4.1.4.1-1, Standard Power/Data Transfer Umbilical Connectors.



* Connector positional tolerances with respect to Line of Symmetry or Line of Androgyny.

FIGURE 3.4.1.4.1-1 STANDARD POWER/DATA TRANSFER UMBILICAL CONNECTORS

3.4.1.4.2 ROTATIONAL MOUNTING REQUIREMENTS

The Plug and Receptacle Connectors shall have a planar rotational tolerance of $\pm 1^\circ$ about the Z-axis.

3.4.1.4.3 CENTERLINE ANGULAR MOUNTING REQUIREMENTS

The Plug and Receptacle Connectors shall be mounted such that the connector centerline (Z-axis) is within a conic tolerance zone. The centerline shall be within $\pm 1^\circ$ about the Z-axis with the apex of the cone being at the coordinate system origin as shown in Figure 3.4.1.4.3-1, Centerline Angular Mounting Requirements.

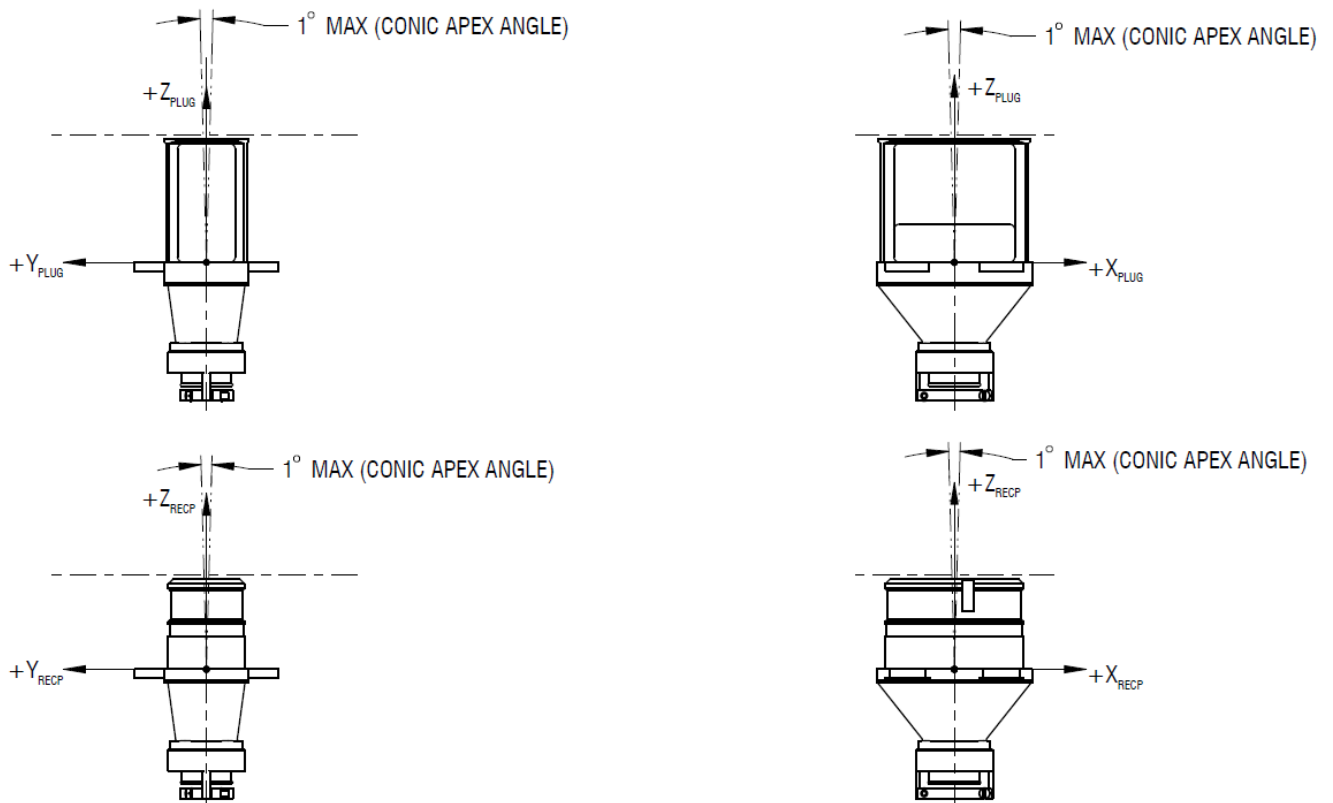

FIGURE 3.4.1.4.3-1 CENTERLINE ANGULAR MOUNTING REQUIREMENTS

3.4.1.4.4 RETRACTION AND EXTENSION MECHANISM

The connector mechanism uses a retraction and extension system to translate the connector and a data bus switch striker to engage with the opposing side.

3.4.1.4.4.1 RETRACTED POSITION

The retraction and extension mechanism shall locate the connector in the position shown in Figure 3.4.1.4.4.1-1, PDTU Retracted Position, prior to commencing docking or undocking operations.

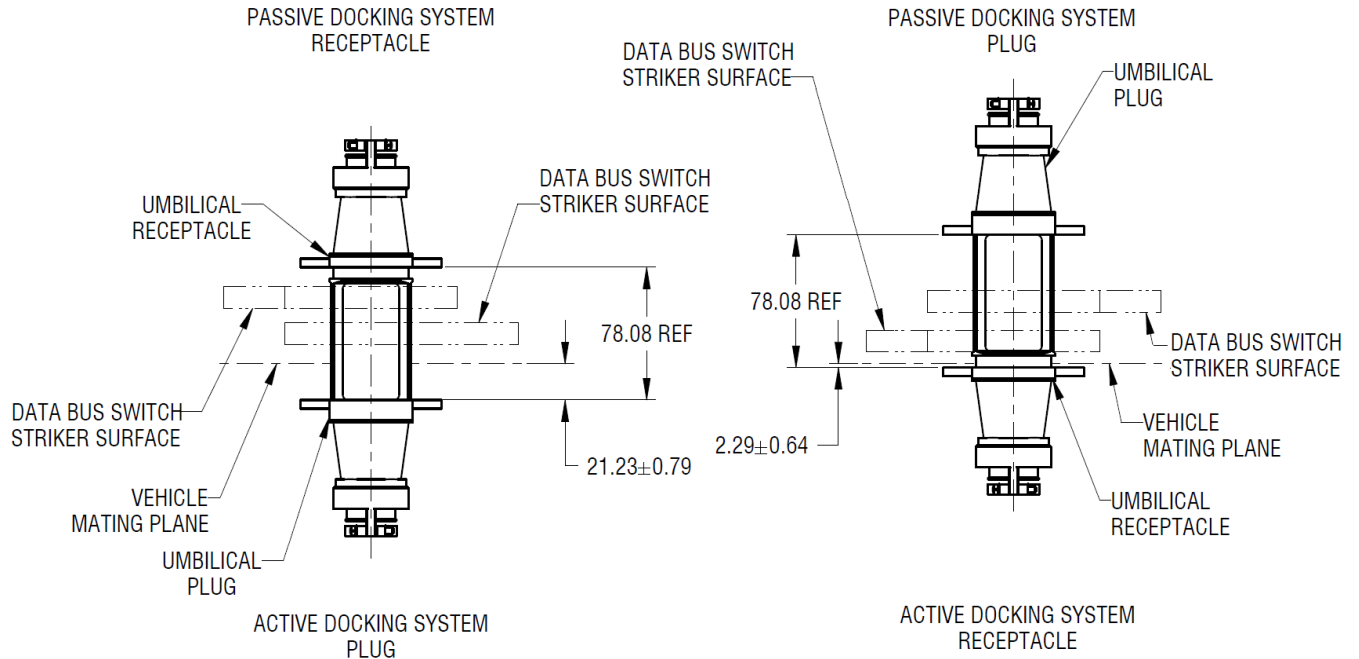

FIGURE 3.4.1.4.4.2-1 PDTU EXTENDED POSITION

3.4.1.5 COMPENSATION OF MISALIGNMENT

During mating operations of the PDTU connectors, planar, angular, and axial system level (across the docking interface) misalignments may be present. The PDTU will have misalignment mechanisms that compensate for combinations of lateral and axial misalignments via mechanical compliance, and provide re-centering of the connector when the PDTU is disconnected.

3.4.1.5.1 PLANAR MISALIGNMENT COMPLIANCE

The Plug Connector shall possess a 3 degree of freedom (3-DOF) planar misalignment mechanism to compensate for lateral and rotational misalignments.

3.4.1.5.1.1 LATERAL MISALIGNMENT COMPLIANCE

The planar misalignment mechanism shall provide a minimum lateral misalignment compliance in both the X and Y directions when subject to zero rotational misalignment. See Figure 3.4.1.5.1.1-1, Plug Lateral Compliance in X Direction, and Figure 3.4.1.5.1.1-2, Plug Lateral Compliance in Y Direction.

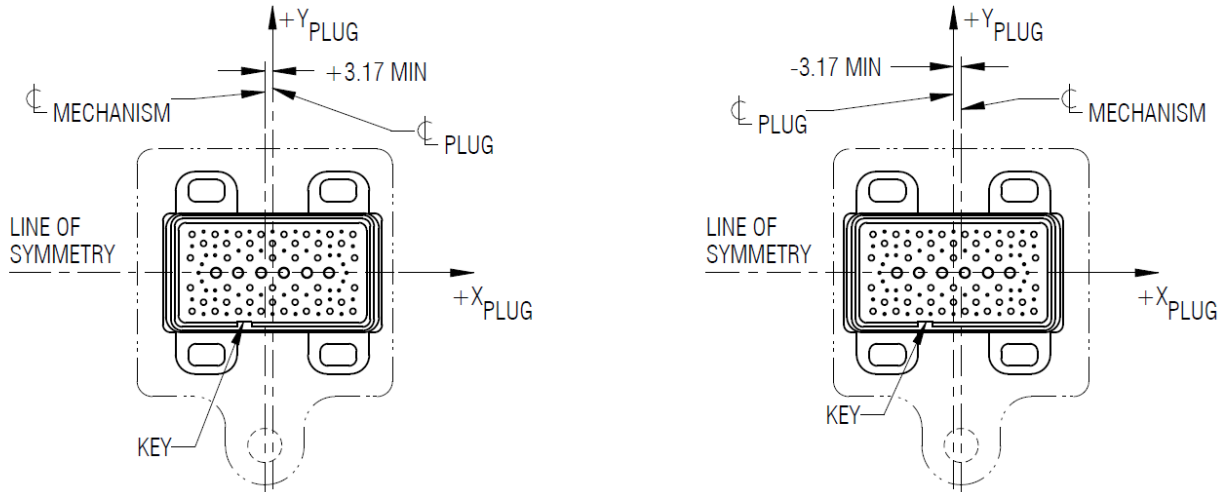

FIGURE 3.4.1.5.1.1-1 PLUG LATERAL COMPLIANCE IN X DIRECTION

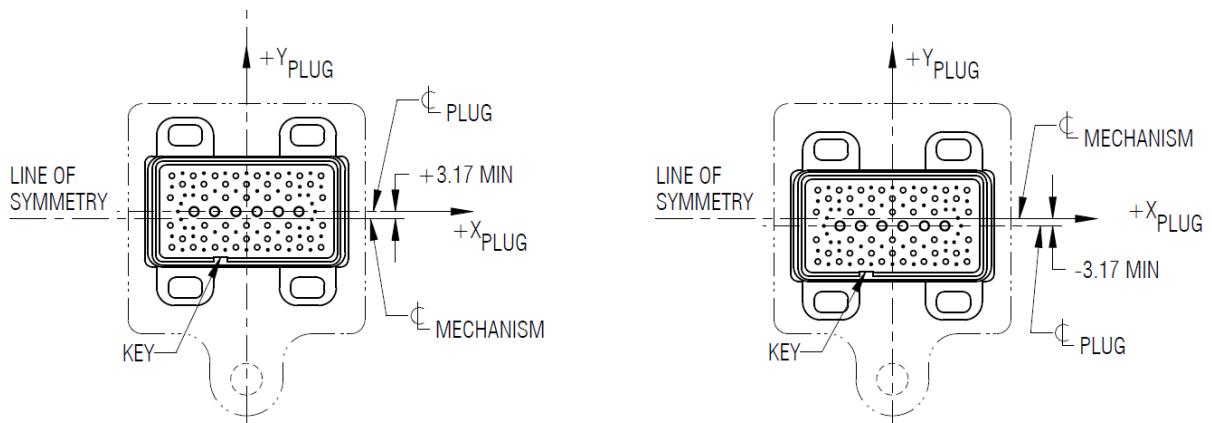

FIGURE 3.4.1.5.1.1-2 PLUG LATERAL COMPLIANCE IN Y DIRECTION

3.4.1.5.1.2 ROTATIONAL MISALIGNMENT COMPLIANCE

The planar misalignment mechanism shall provide a minimum rotational misalignment compliance when subject to zero lateral misalignment. See Figure 3.4.1.5.1.2-1, Plug Rotational Compliance about the Z axis.

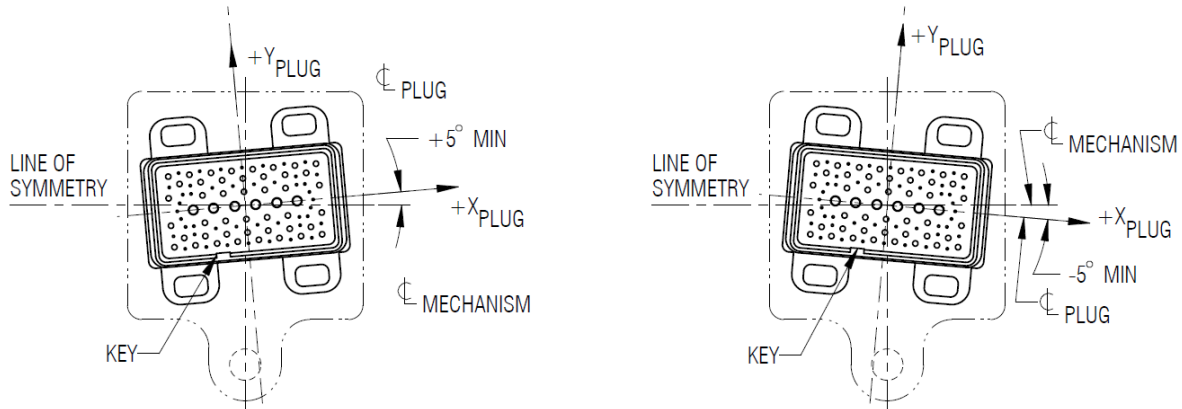

FIGURE 3.4.1.5.1.2-1 PLUG ROTATIONAL COMPLIANCE ABOUT THE Z AXIS

3.4.1.5.1.3 RE-CENTERING CAPABILITY

3.4.1.5.1.3.1 RE-CENTERING LATERAL POSITION

The planar misalignment mechanism shall return the PDTU Connector to its neutral position within the positional tolerance shown in Figure 3.4.1.4.1-1.

3.4.1.5.1.3.2 RE-CENTERING ROTATIONAL POSITION

The planar misalignment mechanism shall return the PDTU Connector to its neutral position within $\pm 1^{\circ}$ as measured from the Plug PDTU mechanism's centerline.

3.4.1.5.1.3.3 RE-CENTERING FORCE

The planar misalignment mechanism lateral re-centering force, at the maximum displacement, and while engaging with the opposing connector, shall be < 64 N.

3.4.1.5.2 AXIAL MISALIGNMENT COMPLIANCE

The Receptacle Connector shall possess a 3-DOF axial misalignment mechanism to accommodate the need for additional stroke along the insertion axis (Z-axis), and rotational misalignments about the X and Y-axes.

3.4.1.5.2.1 AXIAL COMPLIANCE

The axial misalignment mechanism shall provide axial compliance of >5 mm to ensure the proper connector engagement per SSQ 22680 Figure 2g (and shown as reference in Figure 3.4.1.4.4.2-1).

3.4.1.5.2.2 MINIMUM RESISTIVE FORCE

The axial misalignment mechanism must provide a minimum resistive force to ensure sufficient insertion force. The minimum resistive force shall be 20% greater than the maximum force required for the set of pins in the connector as determined from SSQ 22680 Table 4. For example, the minimum resistive force requirement for an IDSS IDD

compliant connector is 128 N, while the requirement for a fully populated connector is 406 N.

3.4.1.5.2.3 MAXIMUM CONNECTOR INSERTION FORCE

The axial misalignment mechanism shall limit the insertion force to 650 N at the maximum compression of the axial compliance mechanism. This requirement prevents connector overload by limiting the insertion force.

3.4.1.5.2.4 ANGULAR COMPLIANCE

The axial misalignment mechanism shall provide the capability to align the connectors for proper mating when angular misalignment exists between connector insertion axes. The maximum angular misalignment is defined as a conic tolerance zone where the centerline is within $\pm 1^\circ$ about the Z-axis with the apex being at the coordinate system origin. See Figure 3.4.1.5.2.4-1, Receptacle Angular Compliance about X and Y-axes.

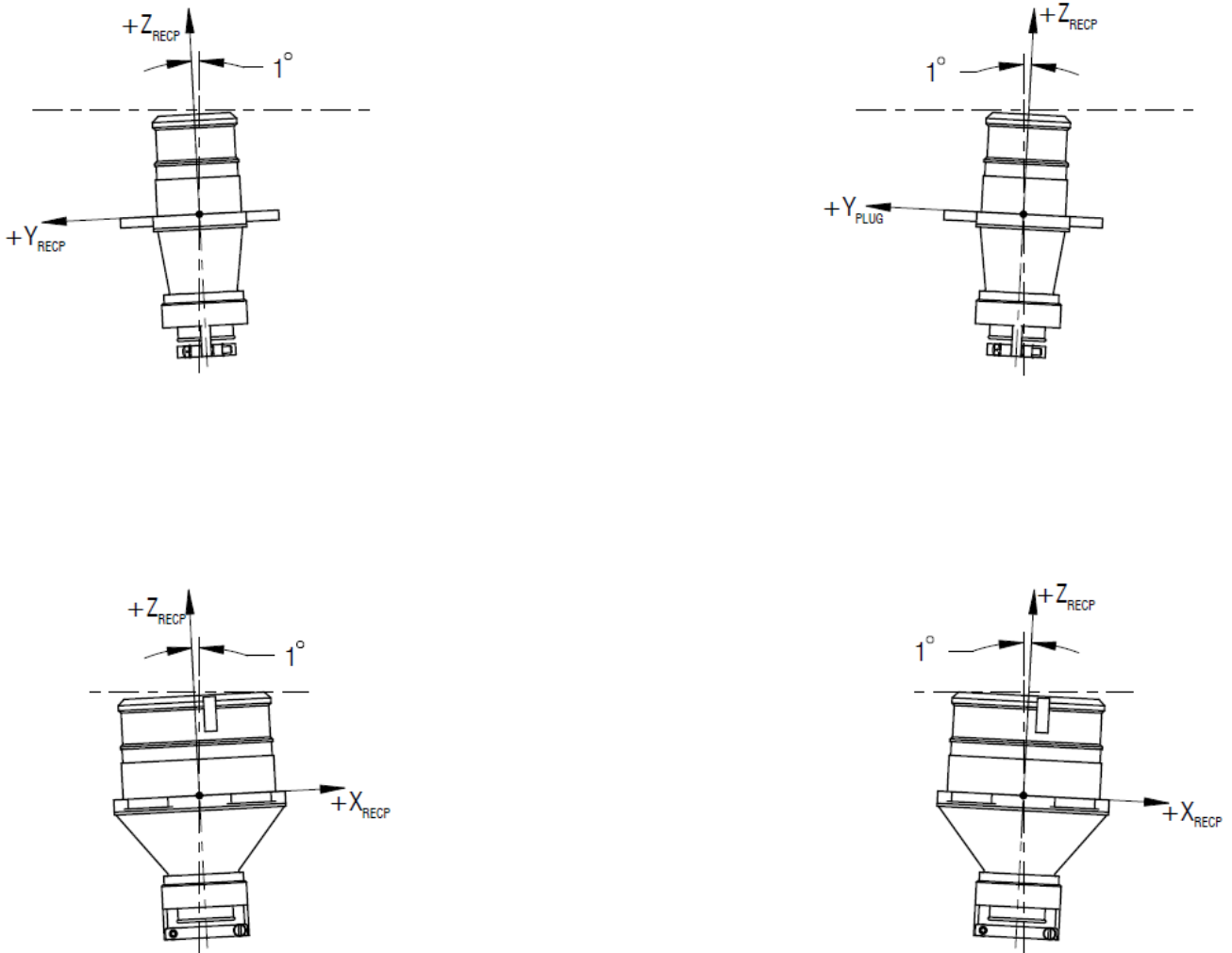

FIGURE 3.4.1.5.2.4-1 RECEPTACLE ANGULAR COMPLIANCE ABOUT X AND Y-AXES

3.4.1.5.3 MISALIGNMENT KEEP OUT ZONE

Any hardware location or mechanism behavior designed to satisfy misalignment compensation requirements shall not exceed the KOZ shown in Figure 3.4-1.

3.4.1.6 STRUCTURAL LOAD REQUIREMENT

The mechanism assembly shall have the capability to accommodate a maximum axial force of 3025 N. This is the requirement for the structural strength of the mechanism assembly when subjected to the highest compression force exerted by the mating active mechanism.

3.4.1.7 DATA BUS SWITCH STRIKER

The PDTU connector carrier shall provide a strike surface to trigger a plunger-style switch on the opposing PDTU connector carrier.

Note: The striker is mounted to the axial translation carriage, and does not move as the connector complies during insertion.

3.4.1.7.1 PLANAR MOUNTING REQUIREMENTS

The Data Bus Switch Striker shall be located laterally per Figure 3.4.1.7.1-1, Data Bus Switch Striker Geometry.



* Minimum striker diameter required at nominal location

FIGURE 3.4.1.7.1-1 DATA BUS SWITCH STRIKER GEOMETRY

3.4.1.7.2 AXIAL MOUNTING REQUIREMENTS

The Data Bus Switch Striker shall be located axially with respect to the associated connector as shown in Figure 3.4.1.4.4.1-1.

3.4.1.7.3 AXIAL LOAD CAPABILITY

The data bus striker shall accommodate a maximum force of 54 N from the data bus switch.

3.4.1.8 PDTU CONNECTOR SHELL CONFIGURATION

The FRAM connector is legacy hardware whose specification was generated and analyzed using English dimensional fits and tolerances. The connector plug, shell, and pin dimensions are given in the English system in order to retain the accuracy of these

fits, as specified in SSQ 22680. Conversion to metric dimensions and fits is up to each implementer.

3.4.1.8.1 PDTU RECEPTACLE SHELL DIMENSIONS

The PDTU receptacle docking interface dimensions are shown in Figure 3.4.1.8.1-1, PDTU Receptacle Dimensions.

3.4.1.8.2 PDTU PLUG SHELL DIMENSIONS

The PDTU plug docking interface dimensions are shown in Figure 3.4.1.8.2-1, PDTU Plug Dimensions.

IDSS IDD Revision D
April 30, 2015

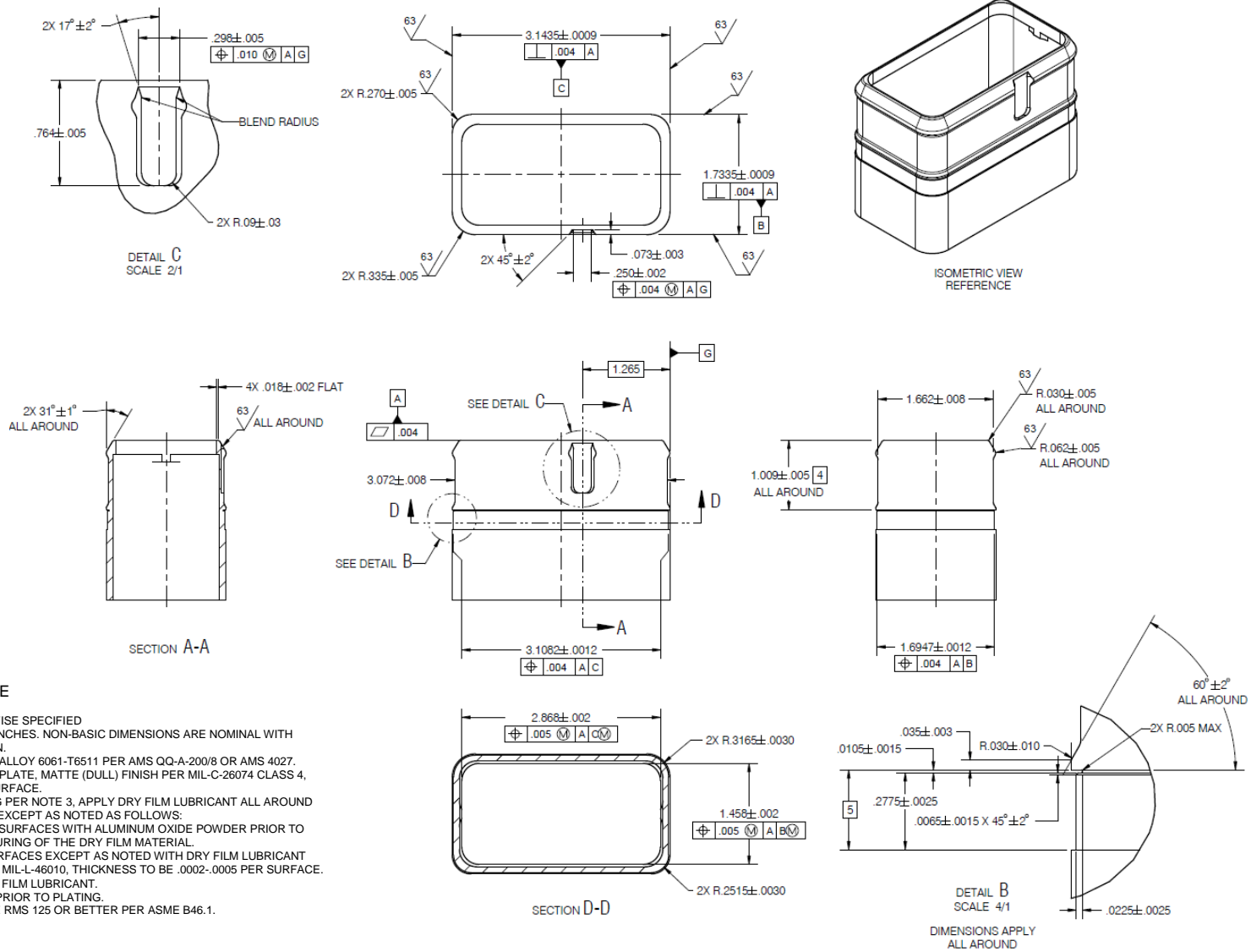

PDTU RECEPTACLE

NOTES: UNLESS OTHERWISE SPECIFIED

1. ALL DIMENSIONS ARE INCHES. NON-BASIC DIMENSIONS ARE NOMINAL WITH TOLERANCE AS SHOWN.
2. MATERIAL: ALUMINUM ALLOY 6061-T6511 PER AMS QQ-A-200/8 OR AMS 4027.
3. ELECTROLESS NICKEL PLATE, MATTE (DULL) FINISH PER MIL-C-26074 CLASS 4, .0015-.0018 THK PER SURFACE.
4. AFTER NICKEL PLATING PER NOTE 3, APPLY DRY FILM LUBRICANT ALL AROUND EXTERNAL SURFACES EXCEPT AS NOTED AS FOLLOWS:
 - A. LIGHTLY BLAST THE SURFACES WITH ALUMINUM OXIDE POWDER PRIOR TO APPLICATION AND CURING OF THE DRY FILM MATERIAL.
 - B. COAT EXTERNAL SURFACES EXCEPT AS NOTED WITH DRY FILM LUBRICANT EVERLUBE 620C PER MIL-L-46010, THICKNESS TO BE .0002-.0005 PER SURFACE.
5. MASK AREA FROM DRY FILM LUBRICANT.
6. DIMENSIONS APPLIED PRIOR TO PLATING.
7. SURFACE FINISH TO BE RMS 125 OR BETTER PER ASME B46.1.

FIGURE 3.4.1.8.1-1 PDTU RECEPTACLE DIMENSIONS

IDSS IDD Revision D
April 30, 2015

PDTU PLUG

NOTES: UNLESS OTHERWISE SPECIFIED

1. ALL DIMENSIONS ARE INCHES. NON-BASIC DIMENSIONS ARE NOMINAL WITH TOLERANCE TBD.
2. MATERIAL: ALUMINUM ALLOY 6061-T6511 PER AMS QQ-A-200/8 OR AMS 4027.
3. ELECTROLESS NICKEL PLATE, MATTE (DULL) FINISH PER MIL-C-26074 CLASS 4, .0015-.0018 THK PER SURFACE.
4. DIMENSIONS APPLIED PRIOR TO PLATING.
5. SURFACE FINISH TO BE RMS 125 OR BETTER PER ASME B46.1.
- 6 MATERIAL: STAINLESS STEEL TYPE 303 CONDITION A PER ASTM A582. CLEAN AND PASSIVATE PER MIL-DTL-5002 AND AMS 2700 TYPE 2.

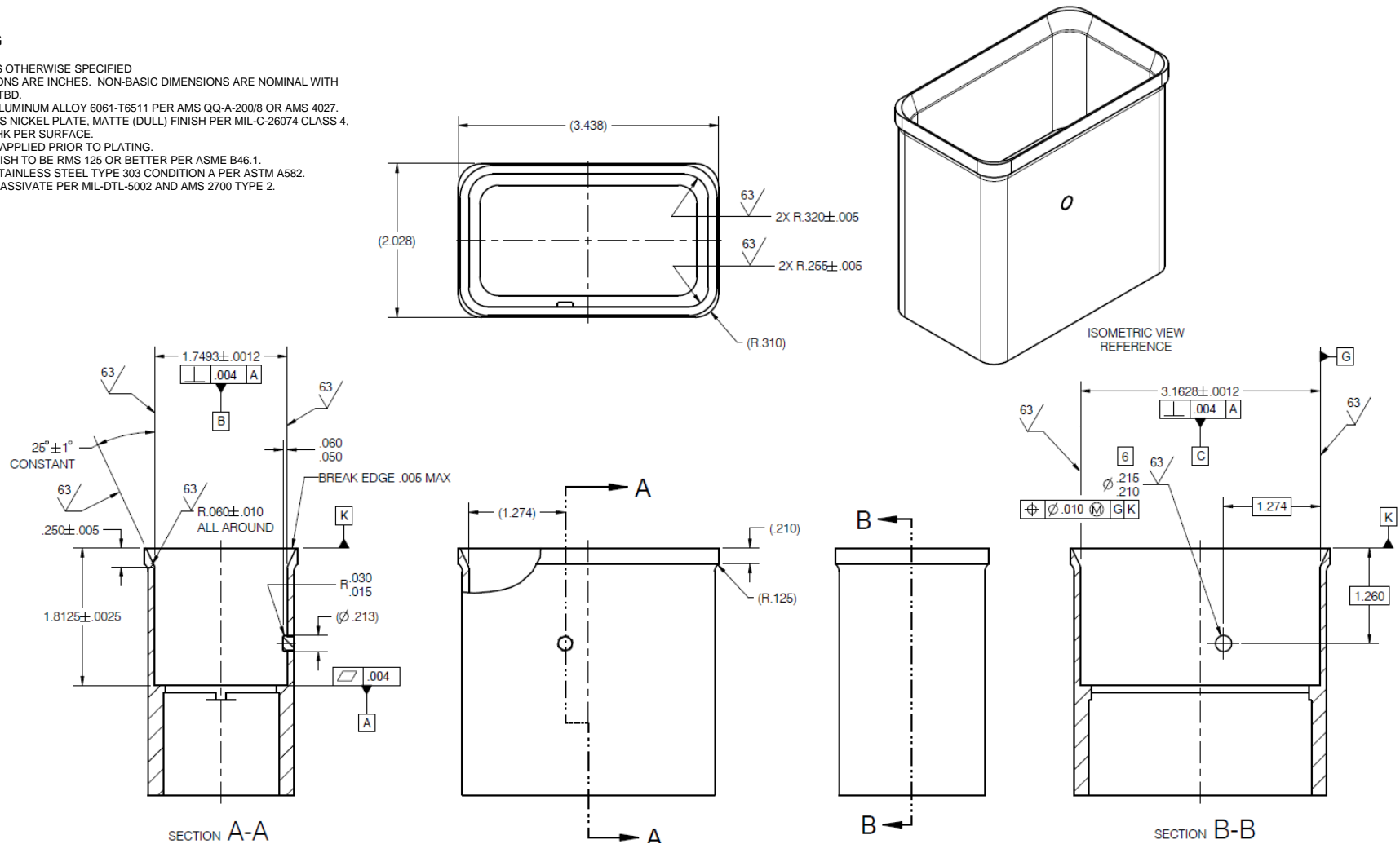

FIGURE 3.4.1.8.2-1 PDTU PLUG DIMENSIONS

3.4.1.9 PDTU PIN CONFIGURATION

The IDSS PDTU connectors shall utilize the connector pinout assignments, as designated in Table 3.4.1.9-1, IDSS PDTU Connector Pinouts, Table 3.4.1.9-2, IDSS PDTU Connector Pinouts Definitions, and in Figure 3.4.1.9-1, Receptacle (Sockets) – Front Face, and Figure 3.4.1.9-2, Plug (Pins) – Front Face. All pins and receptacles identified in Table 3.4.1.9-1 shall be installed. Designer may choose to not install individual pins and their receptacles that are not assigned. Individual pins which are not assigned may be utilized for other mission-specific purposes mutually agreed to by the docking spacecraft partners, while verifying that the signals do not cause issues (for example, electromagnetic interference, thermal, etc.) with the standard IDSS functionality, and are shown in Table 3.4.1.9-3, Unassigned IDSS PDTU Connector Pinouts.

Note that specific functions must be coordinated and documented between the two vehicles (e.g., available power and energy supplied from and to each vehicle, electrical loads, EMI suppression, which vehicle is the MIL-STD-1553 bus master, etc.).

TABLE 3.4.1.9-1 IDSS PDTU CONNECTOR PINOUTS (2 PAGES)

Plug Umbilical Power+Data			Receptacle Umbilical Power+Data		
PIN #	Size	SIGNAL	PIN #	Size	SIGNAL
42	8	120VDC_SysB	42	8	120VDC_SysA
43	8	120VDC_RTN_SysB	43	8	120VDC_RTN_SysA
44	8	User_Def_VDC_SysB	44	8	User_Def_VDC_SysA
45	8	User_Def_VDC_RTN_SysB	45	8	User_Def_VDC_RTN_SysA
46	8	Ground Safety Wire_SysB	46	8	Ground Safety Wire_SysA
16	12	28VDC_SysB	16	12	28VDC_SysA
29	12	28VDC_RTN_SysB	29	12	28VDC_RTN_SysA
28	12	28VDC_SysB	28	12	28VDC_SysA
41	12	28VDC_RTN_SysB	41	12	28VDC_RTN_SysA
40	12	28VDC_SysB	40	12	28VDC_SysA
39	12	28VDC_RTN_SysB	39	12	28VDC_RTN_SysA
48	12	28VDC_SysB	48	12	28VDC_SysA
61	12	28VDC_RTN_SysB	61	12	28VDC_RTN_SysA
60	12	28VDC_SysB	60	12	28VDC_SysA
73	12	28VDC_RTN_SysB	73	12	28VDC_RTN_SysA
13	20	SysB_100BaseT_RX_P_BI_DB_P	13	20	SysA_100BaseT_TX_P_BI_DA_P
27	20	SysB_100BaseT_RX_N_BI_DB_N	27	20	SysA_100BaseT_TX_N_BI_DA_N
86	20	SysB_100BaseT_TX_P_BI_DA_P	86	20	SysA_100BaseT_RX_P_BI_DB_P
72	20	SysB_100BaseT_TX_N_BI_DA_N	72	20	SysA_100BaseT_RX_N_BI_DB_N

TABLE 3.4.1.9-1 IDSS PDTU CONNECTOR PINOUTS (2 PAGES)

Plug Umbilical Power+Data			Receptacle Umbilical Power+Data		
PIN #	Size	SIGNAL	PIN #	Size	SIGNAL
14	20	SysB_1GEth_BI_DC_P	14	20	SysA_1GEth_BI_DD_P
15	20	SysB_1GEth_BI_DC_N	15	20	SysA_1GEth_BI_DD_N
87	20	SysB_1GEth_BI_DD_P	87	20	SysA_1GEth_BI_DC_P
88	20	SysB_1GEth_BI_DD_N	88	20	SysA_1GEth_BI_DC_N
25	20	SysB_1553_BUS1_P	25	20	SysA_1553_BUS1_P
38	20	SysB_1553_BUS1_N	38	20	SysA_1553_BUS1_N
70	20	SysB_1553_BUS2_P	70	20	SysA_1553_BUS2_P
57	20	SysB_1553_BUS2_N	57	20	SysA_1553_BUS2_N
19	20	SysB_1553_BUS3_P	19	20	SysA_1553_BUS3_P
32	20	SysB_1553_BUS3_N	32	20	SysA_1553_BUS3_N
51	20	SysB_1553_BUS4_N	51	20	SysA_1553_BUS4_N
64	20	SysB_1553_BUS4_P	64	20	SysA_1553_BUS4_P
21	20	SysB_Umb_Plug_LoopBack_P	21	20	Short_to_pin_34
34	20	SysB_Umb_Plug_LoopBack_N	34	20	Short_to_pin_21
53	20	Short_to_pin_66	53	20	SysA_Umb_Receptacle_LoopBack_P
66	20	Short_to_pin_53	66	20	SysA_Umb_Receptacle_LoopBack_N

Notes:

- 1) System A will be crossed to System B when identically configured vehicles are mated.
- 2) Cable shields are intended to be grounded to backshell.

TABLE 3.4.1.9-2 IDSS PDTU CONNECTOR PINOUTS DEFINITIONS (2 PAGES)

PIN #	DEFINITION
13	100 Base TX (IEEE 802.3u Ethernet) Receive/Transmit positive wire (also used as BI_DB_P/BI_DA_P for gigabit Ethernet)
14	Gigabit Ethernet (IEEE 802.3z) BI_DC_P/BI_DD_P wire
15	Gigabit Ethernet (IEEE 802.3z) BI_DC_N/BI_DD_N wire
16	28 Volts Direct Current from System A or B. Sinks or sources voltage between vehicles.
19	MIL-STD-1553 Bus 3 positive
21	Umbilical loopback positive is shorted with pin 34 on system A. This allows the B system to detect mating.
25	MIL-STD-1553 Bus 1 positive
27	100 Base TX (IEEE 802.3u Ethernet) Receive/Transmit negative wire (also used as BI_DB_N/BI_DA_N for gigabit Ethernet)
28	Volts Direct Current from System A or B. Sinks or sources voltage between vehicles.
29	Volts Direct Current from System A or B. Return line for 28 volt line.
32	MIL-STD-1553 Bus 3 negative
34	Umbilical loopback negative is shorted with pin 21 on system A. This allows the B system to detect mating.
38	MIL-STD-1553 Bus 1 negative

TABLE 3.4.1.9-2 IDSS PDTU CONNECTOR PINOUTS DEFINITIONS (2 PAGES)

PIN #	DEFINITION
39	28 Volts Direct Current from System A or B. Return line for 28 volt line.
40	28 Volts Direct Current from System A or B. Sinks or sources voltage between vehicles.
41	28 Volts Direct Current from System A or B. Return line for 28 volt line.
42	120 Volts Direct Current from System A or B. Sinks or source voltage between vehicles.
43	120 Volts Direct Current Return from System A or B. Return for 120 volt.
44	Direct Current (user-defined voltage) from System A or B. Sinks or sources voltage between vehicles. Also serves as mating guide for connector.
45	Direct Current (user-defined voltage) from System A or B. Return line for pin 44. Also serves as mating guide for connector.
46	Ground Safety Wire provides bonding ground connection between vehicles.
48	28 Volts Direct Current from System A or B. Sinks or sources voltage between vehicles.
51	MIL-STD-1553_Bus 4 negative
53	Umbilical loopback positive is shorted with pin 66 on system B. This allows the A system to detect mating.
57	MIL-STD-1553_Bus 2 negative
60	28 Volts Direct Current from System A or B. Sinks or sources voltage between vehicles.
61	28 Volts Direct Current from System A or B. Return line for 28 volt line.
64	MIL-STD-1553 Bus 4 positive
66	Umbilical loopback positive is shorted with pin 53 on system B. This allows the A system to detect mating.
70	MIL-STD-1553 Bus 2 positive
72	100 Base TX (IEEE 802.3u Ethernet) Transmit/Receive positive wire (also used as BI_DA_N/BI_DB_N for gigabit Ethernet)
73	28 Volts Direct Current from System A or B. Return line for 28 volt line.
86	100 Base TX (IEEE 802.3u Ethernet) Transmit/Receive positive wire (also used as BI_DA_P/BI_DB_P for gigabit Ethernet)
87	Gigabit Ethernet (IEEE 802.3z) BI_DD_P/BI_DC_P wire
88	Gigabit Ethernet (IEEE 802.3z) BI_DC_N/BI_DC_N wire

TABLE 3.4.1.9-3 UNASSIGNED IDSS PDTU CONNECTOR PINOUTS

Size	Pin Numbers
8	47
12	5, 7, 9, 11, 18, 20, 22, 24, 26, 30, 31, 33, 35, 37, 49, 50, 52, 54, 56, 58, 59, 63, 65, 67, 69, 71, 78, 80, 82, 84
20	1, 2, 3, 4, 6, 8, 12, 17, 23, 36, 55, 62, 68, 74, 75, 76, 77, 79, 81, 83, 85

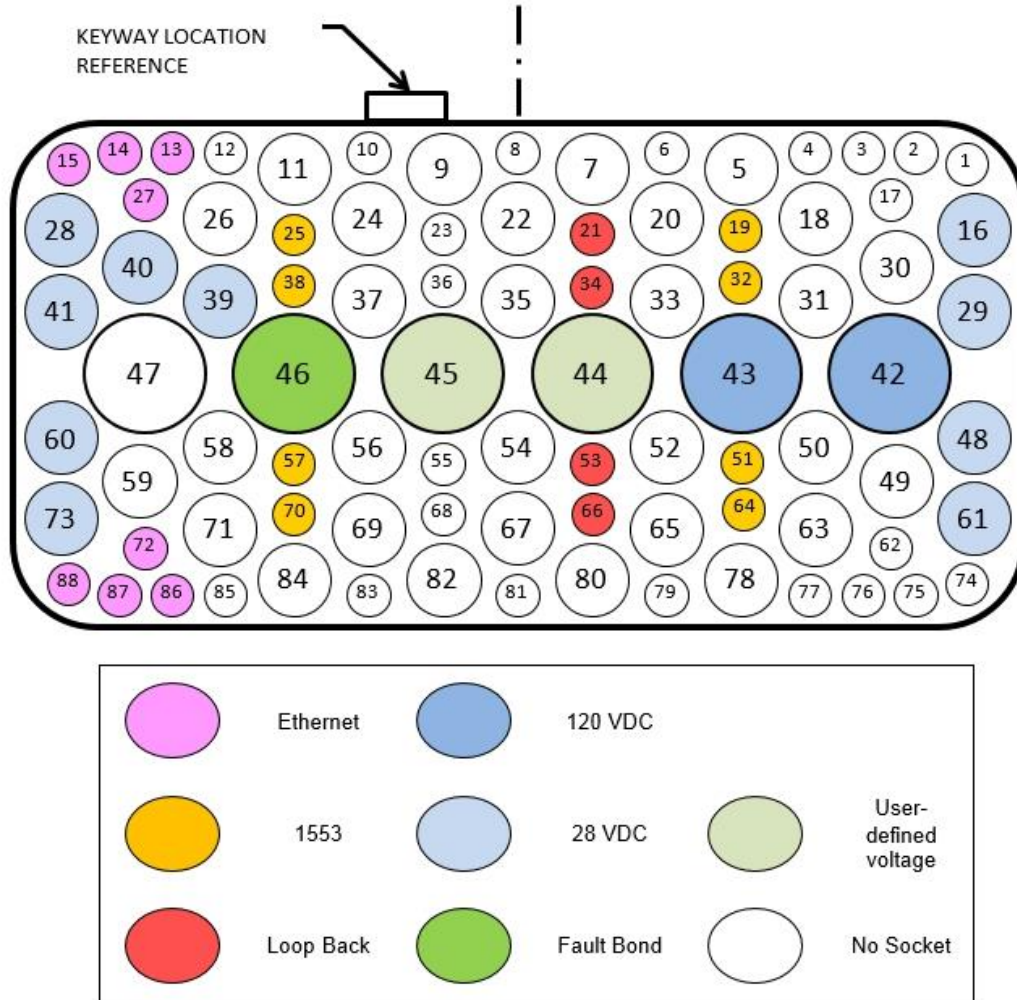

FRONT FACE OF RECEPTACLE INSERT SHOWN, PLUG OPPOSITE
FIGURE 3.4.1.9-1 RECEPTACLE (SOCKETS) - FRONT FACE

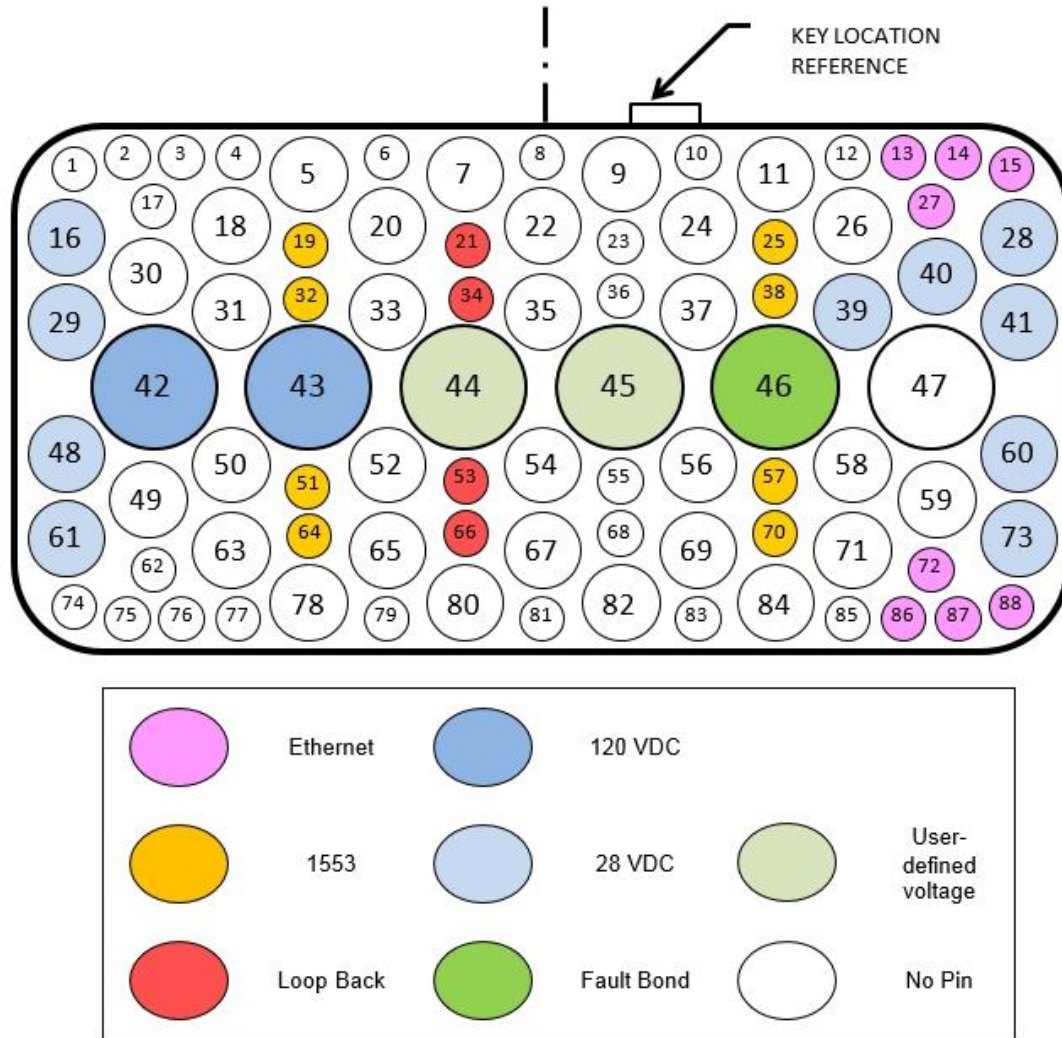

FRONT FACE OF PLUG INSERT SHOWN, RECEPTACLE OPPOSITE
FIGURE 3.4.1.9-2 PLUG (PINS) - FRONT FACE

3.4.1.9.1 POWER TRANSFER PINS

Each PDTU connector has six size 8 pins (as defined in SSQ 22680), but utilizes only five of these pins for power transfer. The pins on either side of the interface must be assigned to match the mating vehicle for the desired power transfer; this allows transfer of two independent power circuits in a single connector.

Additionally, pins 44 and 45 are required to serve as a mating guide for the connectors even if they are not otherwise used.

In addition to the size 8 pins, 5 pairs of size 12 pins are provided for additional 28VDC power transfer capability.

IDSS IDD Revision D
April 30, 2015

The actual power transfer possible depends on the ambient temperature, the source and load characteristics, and wiring factors that are not part of the PDTU interface. As specified in SSQ 22680 section 3.2.1.6, the electrical current passing through all pins on the connector must not cause the shell, the contacts, or the insert to exceed +200 °C (+392 °F) at the maximum anticipated ambient temperature. Mating vehicles must prearrange which vehicle will supply power, how much can be supplied, the voltage range, power source and load characteristics, and any electromagnetic interference-related parameters.

3.4.1.9.2 DATA TRANSFER PINS

The PDTU has separate pins for two independent U.S. MIL-STD-1553B busses (two busses, each with an A and B bus) and two IEEE 802.3u 100 Base TX Ethernet data transfer between the docked vehicles. It is permissible to use pins 13, 27, 72, and 86 for 802.3u 100 Base TX Ethernet data transfer. If Gigabit (IEEE 802.3ab 1000 Base T) Ethernet is desired, pins 13, 14, 15, 27, 72, 86, 87, and 88 are used. The two vehicles must agree on the standard, protocols, address assignment, routing, and all other network details.

If an implementing organization chooses to use a 1553 bus termination switch as part of their avionics architecture (making use of the Data Bus Switch Striker defined in section 3.4.1.7), that organization is responsible for the design and installation of the switch on the active bus side of the interface per their own standards.

3.4.1.9.3 PDTU CONNECTOR MATED INDICATION

IDSS compliant systems shall short together the two pairs of pins in the PDTU connector in accordance with Table 3.4.1.9-1. When the connectors mate, this short can be sensed by the docking vehicles using the Loop Back pins. This is an independent indication that the connectors are seated and the pins have engaged, which signifies that power and data can be exchanged.

3.4.2 WATER TRANSFER

Reserved

3.4.3 FUEL TRANSFER

Reserved

3.4.4 PRESSURANT TRANSFER

Reserved

3.4.5 OXIDIZER TRANSFER

Reserved

3.5 DOCKING NAVIGATION AIDS

The IDSS includes three different types of target systems to support docking, as shown in Figure 3.5-1, IDSS Target Systems: the Perimeter Reflector Targets (PRT), the

IDSS IDD Revision D
April 30, 2015

Peripheral Docking Target (PDT), and the Centerline Docking Target (CDT). These targets work together to support short range as well as longer-range operations and allow for different types of sensor systems or technologies that may be available on the active vehicle during proximity operations and docking, as described in Figure 3.5-2, Availability of Docking Navigation Aids.

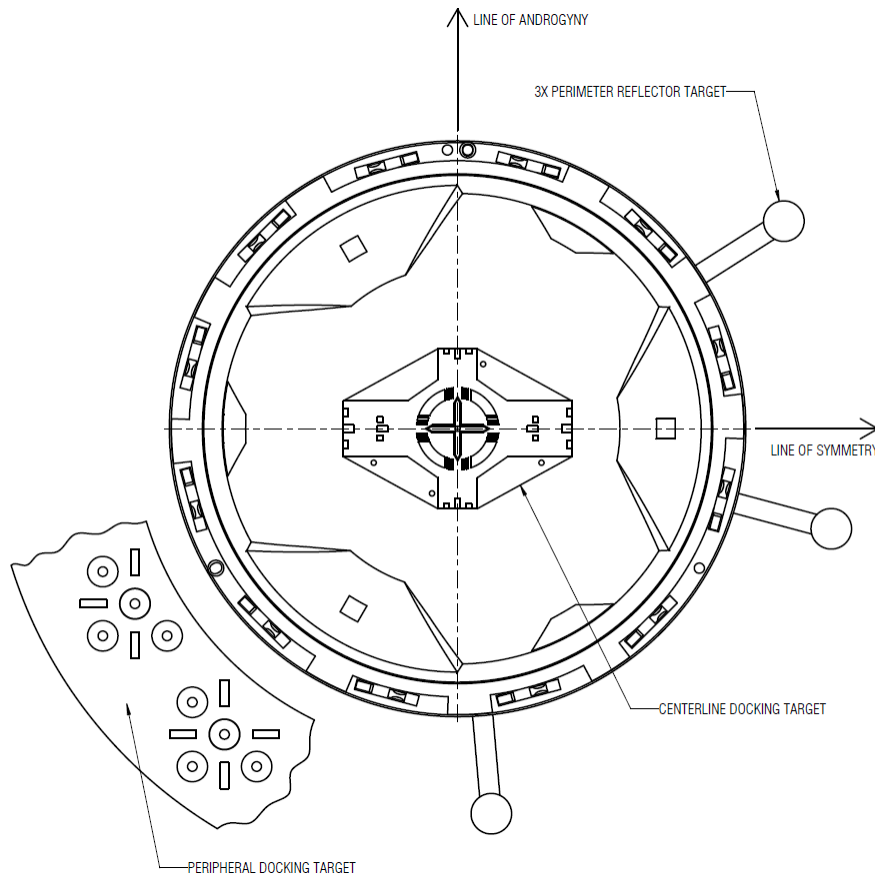

FIGURE 3.5-1 IDSS TARGET SYSTEMS

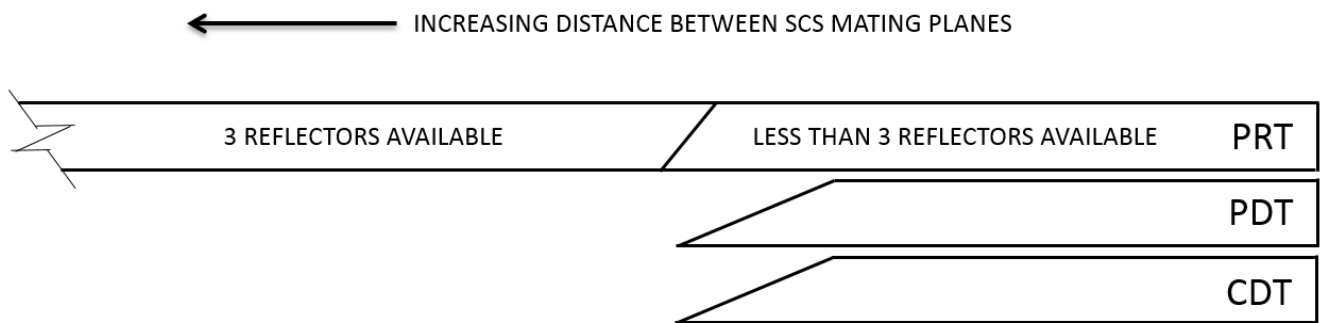

FIGURE 3.5-2 AVAILABILITY OF DOCKING NAVIGATION AIDS

The PRTs consist of three retro-reflector assemblies which have been located around the perimeter of the docking system to allow for unobstructed line-of-sight viewing from longer ranges. Two of the retro-reflectors are hemispherical (that is, they have a

hemispherical field of regard) and allow for sensor tracking coverage above and below the docking axis to provide support in docking axis acquisition. The third retro-reflector (with a ± 30 degree field of regard) provides support for maintaining the docking axis during approach. The field of regard of all the reflective elements are shown together in Figure 3.5-3, Reflector Fields of Regard. The PDT and the CDT provide references to allow the active vehicle to measure its alignment relative to the docking interface. The vehicle can use either the CDT or the PDT.

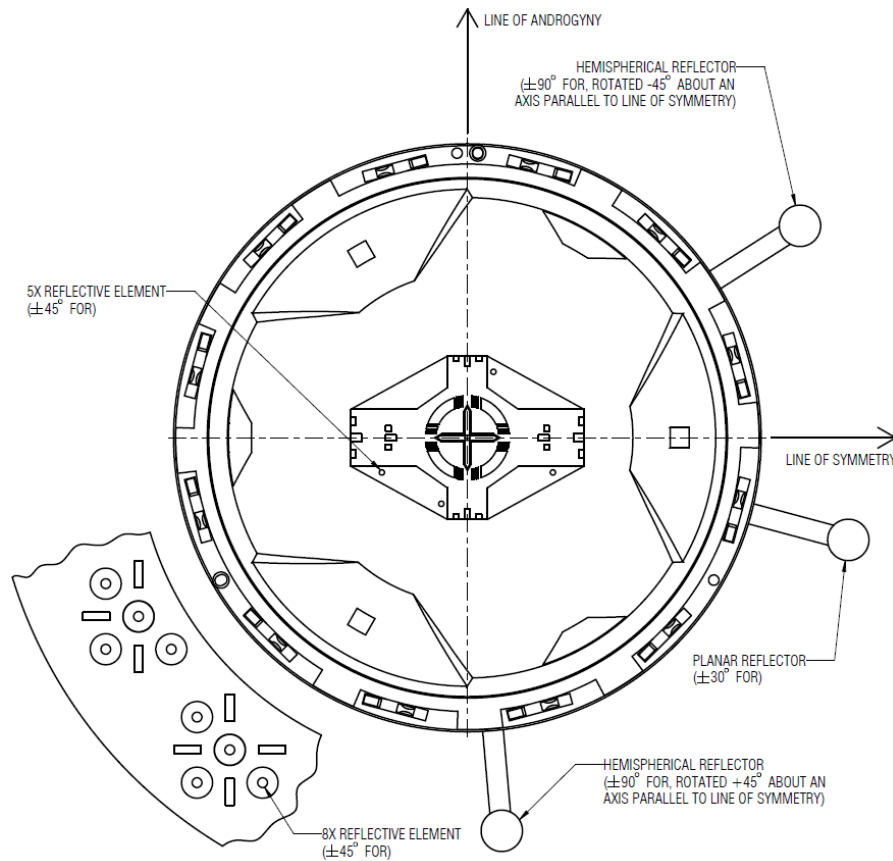

FIGURE 3.5-3 REFLECTOR FIELDS OF REGARD

The CDT is compatible for use with optical and laser sensors. The backplate is printed with markings designed to allow for reading of the lateral and angular alignment cues on the docking target. The CDT includes reflectors under filter glass that are compatible with laser sensors.

The PDT is compatible for use with visible cameras, thermal imagers, or laser sensors. The PDT includes reflectors under filter glass that are compatible with optical and laser sensors.

The combination of the PRT, PDT, and CDT provide navigation support for active vehicle operations at long, mid, and short ranges. These three target systems allow for the use of various relative sensor technologies and therefore provide flexibility in sensor selection. Multiple options exist for sensor redundancy in providing a relative navigation

estimate suitable for final approach and docking operations. Updates to target standards will be considered as new relative sensor technologies develop.

Dimensions given in section 3.5 show assembly-level design tolerances. Having accurate knowledge of the final as installed docking target feature locations is critical in achieving the Guidance Navigation & Control (GN&C) performance required for successful docking capture.

3.5.1 PERIMETER REFLECTOR TARGETS

The PRTs are a series of retro-reflector assemblies located around the perimeter of the passive docking vehicle's docking port and are shown in Figure 3.5-1. The reflectors are precision passive optical targets and do not require power. Two types of reflector assemblies are used, hemispherical (with a hemispherical field-of-regard) and planar (with a narrower field-of-regard). Both types use corner cubes.

3.5.1.1 PRT PLACEMENT

Each PRT shall be located as defined in Figure 3.5.1.1-1, PRT Locations.

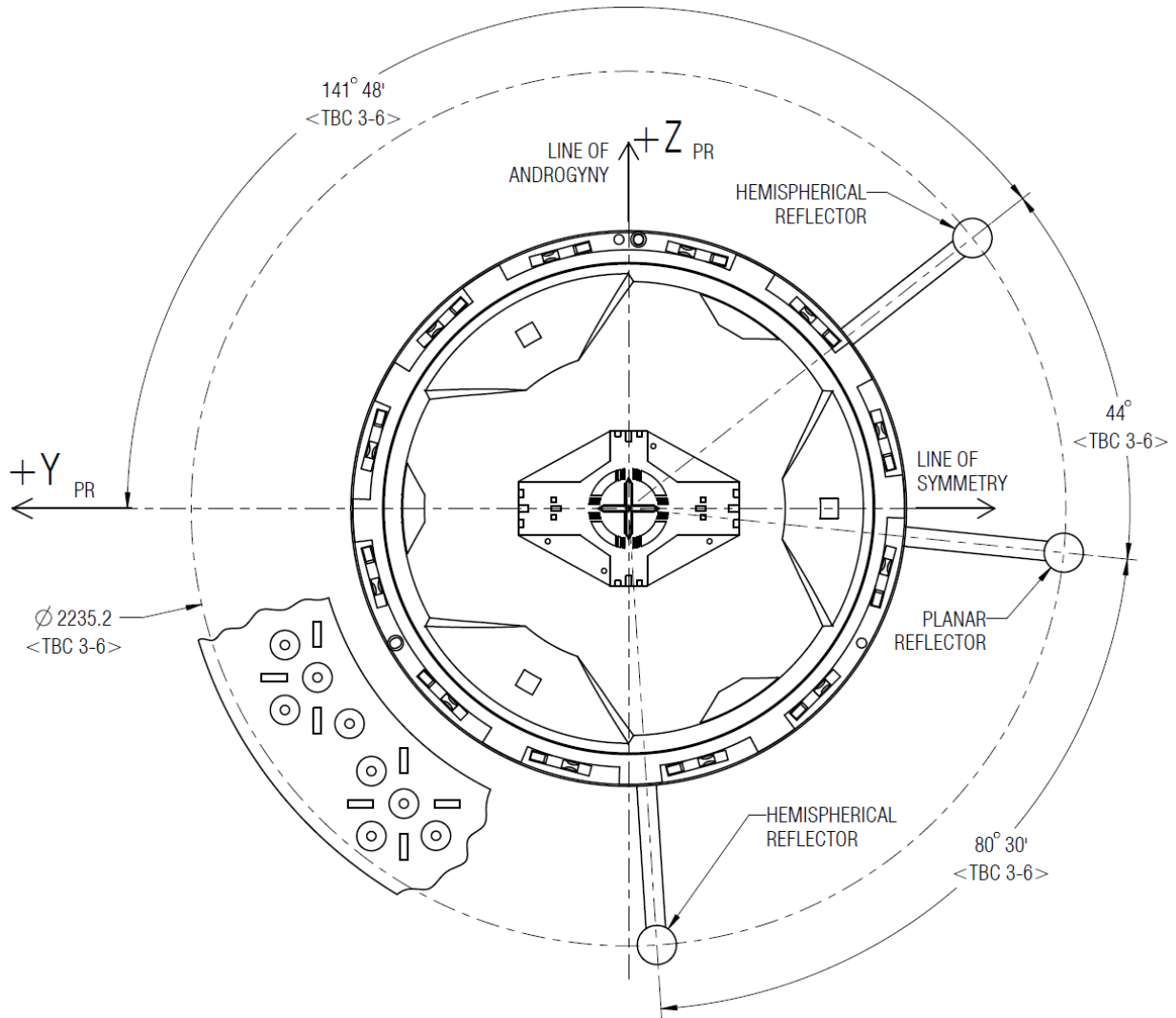

FIGURE 3.5.1.1-1 PRT LOCATIONS

3.5.1.1.1 NUMBER OF PRT RETRO REFLECTORS

The PRT shall have three (3) retro reflectors.

3.5.1.1.2 PRT HEMISPHERICAL RETRO REFLECTOR FIELD OF REGARD

The hemispherical retro reflectors shall provide a reflector field of regard as defined in Figure 3.5.1.1.2-1, Perimeter Hemispherical Reflector Target Assembly Boresight.

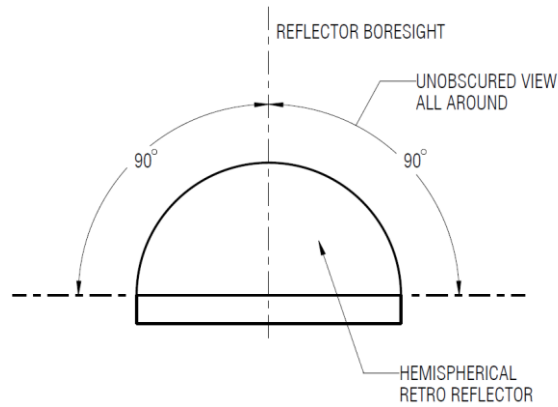

Note: Field-of-regard shown is local to the retro reflector, and does not consider surrounding vehicle structure.

FIGURE 3.5.1.1.2-1 PERIMETER HEMISPHERICAL REFLECTOR TARGET ASSEMBLY BORESIGHT

3.5.1.1.3 PRT PLANAR RETRO REFLECTOR FIELD OF REGARD

The planar retro reflector shall provide a reflector field of regard as defined in Figure 3.5.1.1.3-1, Perimeter Planar Reflector Target Assembly Boresight.

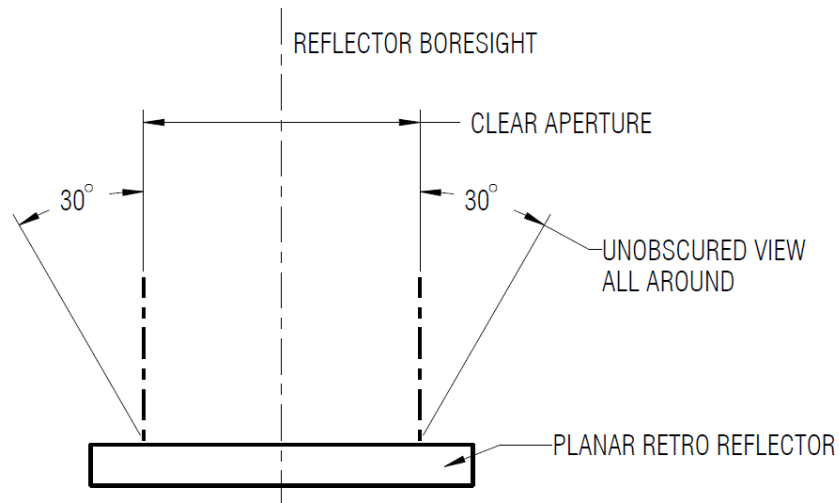

FIGURE 3.5.1.1.3-1 PERIMETER PLANAR REFLECTOR TARGET ASSEMBLY BORESIGHT

3.5.1.1.4 PRT RETRO REFLECTOR FIELD OF REGARD ORIENTATION

The PRT retro reflectors fields of regard shall be oriented with respect to the docking axis as shown in Figure 3.5.1.1.4-1, Perimeter Reflector Target Orientation.

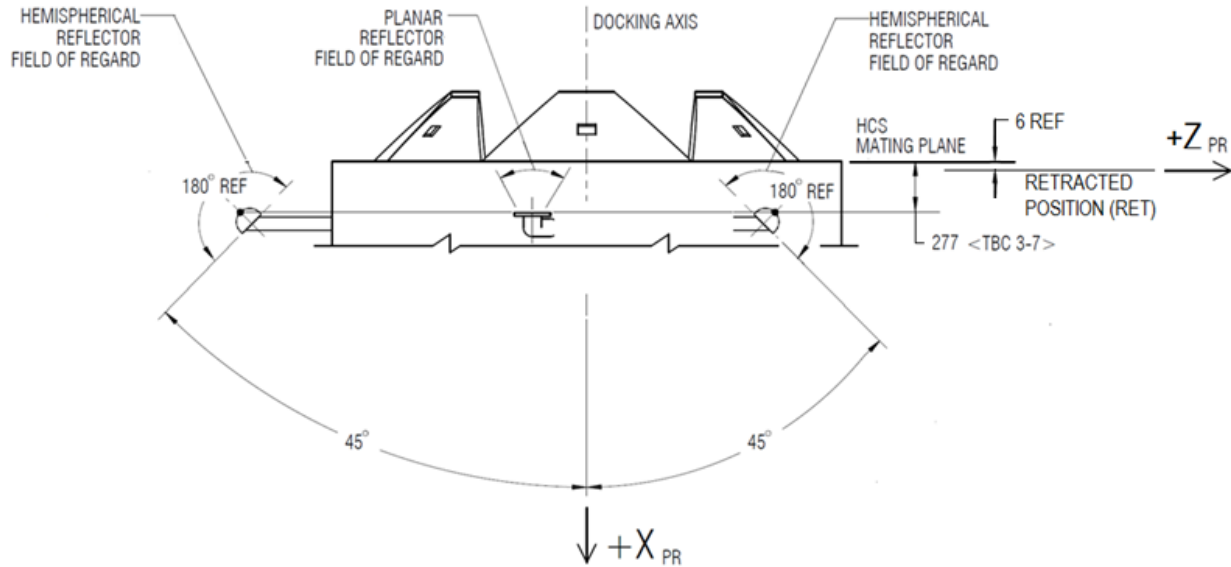

FIGURE 3.5.1.1.4-1 PERIMETER REFLECTOR TARGET ORIENTATION

3.5.1.1.5 PRT PLANAR RETRO REFLECTOR BORESIGHT ALIGNMENT

The planar retro reflector boresight shall be co-aligned with the docking axis.

3.5.1.1.6 PRT REFLECTOR DEPTH

The PRT reflectors shall be located with respect to the HCS mating plane as shown in Figure 3.5.1.1.4-1.

3.5.1.2 REFLECTOR CHARACTERISTICS

<TBS 3-1>

3.5.2 CENTERLINE DOCKING TARGET

The CDT shall consist of the Centerline Visual Target (CVT) and the Centerline Reflector Target (CRT). The major features of the CDT are shown in Figure 3.5.2-1, Centerline Docking Target.

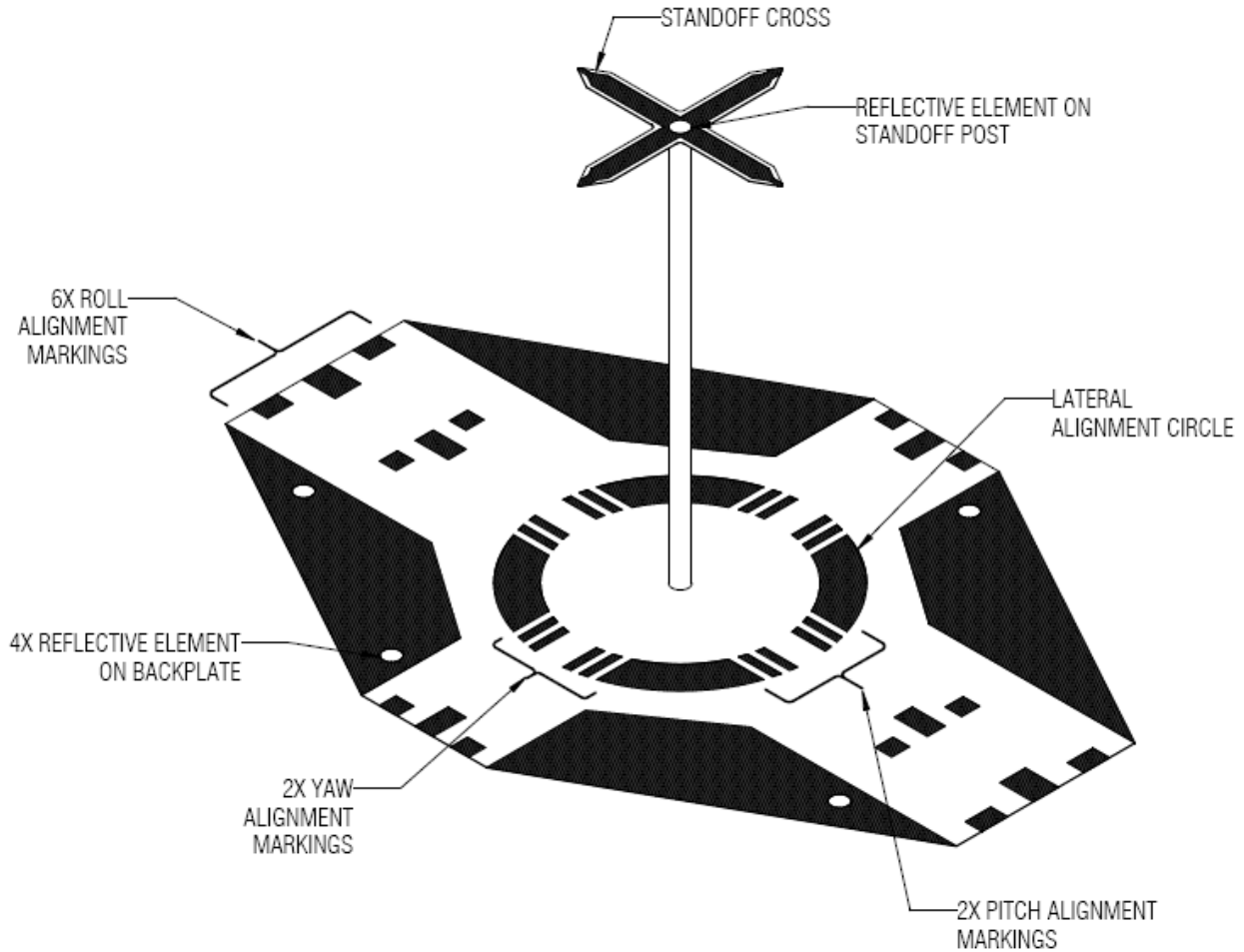
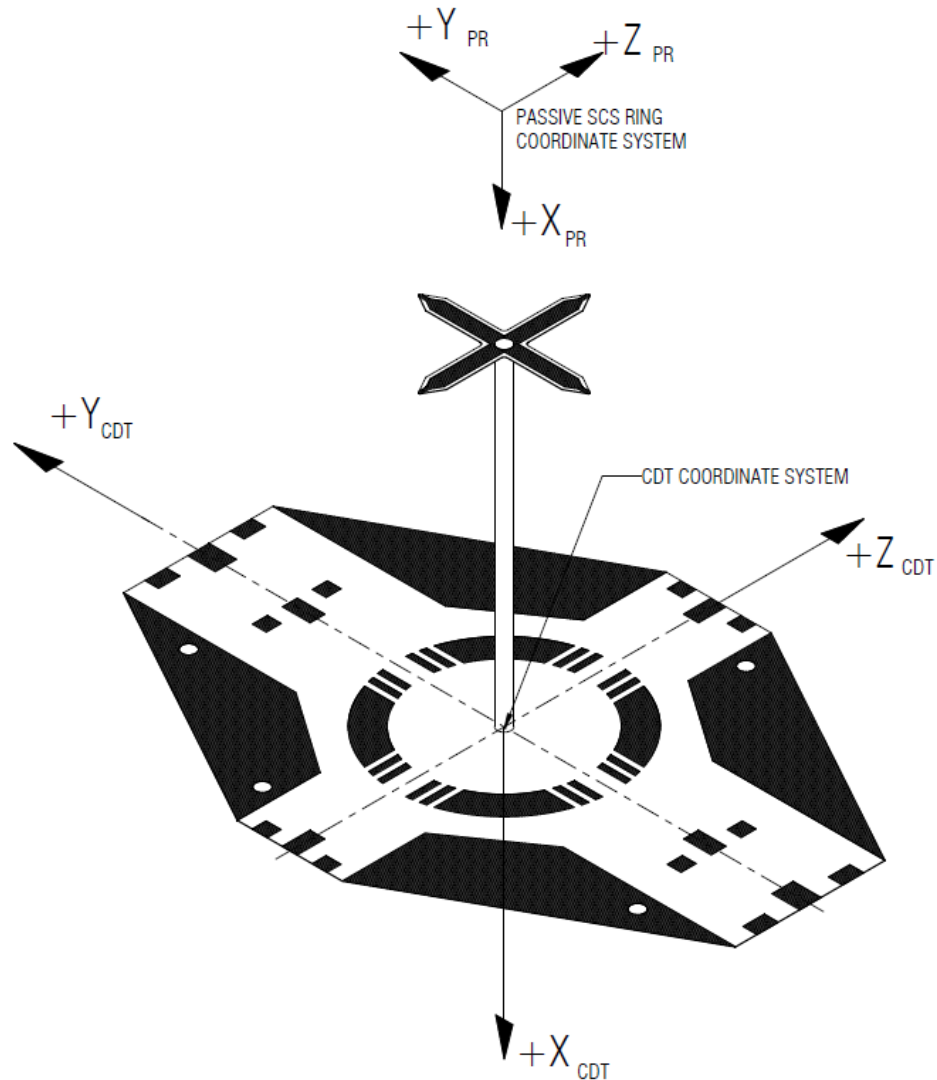

FIGURE 3.5.2-1 CENTERLINE DOCKING TARGET

3.5.2.1 CDT COORDINATE SYSTEM

The CDT Coordinate System is a right-handed Cartesian system, and is shown in Figure 3.5.2.1-1, CDT Coordinate System. Its origin is the center of the CDT Backplate on the plane of the CDT Backplate front surface. The CDT Coordinate System axes are aligned with the Passive SCS Ring Coordinate System axes.



NOTES:

1. The CDT Backplate shall be mounted so that each axis of the CDT Coordinate System is within an angular tolerance of $\pm 0^{\circ}6'$ **<TBC 3-2>** with respect to each axis of the Passive SCS Ring Coordinate System.
2. The CVT Standoff Element shall have a roll tolerance of $\pm 0^{\circ}15'$ **<TBC 3-2>** about the X-axis of the CDT Coordinate System.

FIGURE 3.5.2.1-1 CDT COORDINATE SYSTEM

3.5.2.2 CENTERLINE VISUAL TARGET

The CVT provides visual cues to estimate lateral position misalignments as well as angular misalignments in three axes. The markings on the backplate allow an estimation of the angular misalignments to within 1 degree per axis. The CVT is designed to provide alignment cues when viewing the target in the visible wavelengths.

3.5.2.2.1 CVT COMPONENTS

The CVT shall consist of a backplate and Standoff Cross Assembly. The Standoff Element, defined by the Cross Element and the attached reflector, and the Standoff Rod are components of the Standoff Cross Assembly.

3.5.2.2.2 CDT BACKPLATE LATERAL POSITION MOUNTING TOLERANCE

The center of the CDT backplate shall be mounted with a positional mounting tolerance with respect to the Passive SCS Ring X-axis as shown in Figure 3.5.2.2.2-1, CVT Alignment.

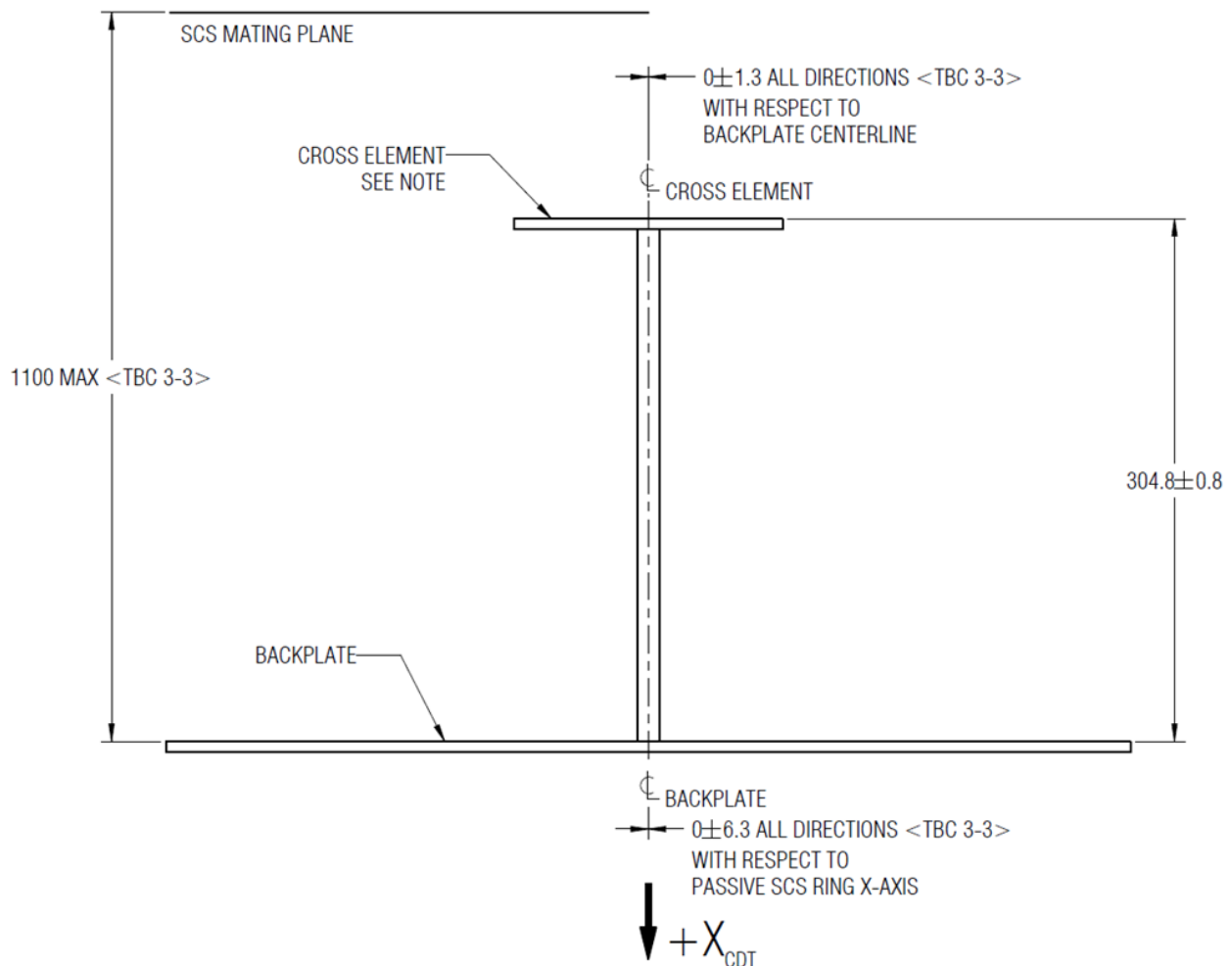

NOTE: The front face of the Standoff Cross shall be parallel to the front face of the Backplate with an angular tolerance of $\pm 0^{\circ}01'30'' <TBC 3-3>$ in any direction.

FIGURE 3.5.2.2.2-1 CVT ALIGNMENT

3.5.2.2.3 CDT BACKPLATE ANGULAR MOUNTING TOLERANCE

The CDT Backplate shall be mounted with a maximum angular mounting tolerance as described in Figure 3.5.2.1-1.

3.5.2.2.4 CVT STANDOFF ELEMENT HEIGHT

The CVT shall have a standoff element extending from the surface of the Backplate, as shown in Figure 3.5.2.2.2-1.

3.5.2.2.5 CVT STANDOFF CROSS LOCATION

The center of the cross element shall be located with a maximum positional mounting tolerance with respect to the CDT Backplate centerline as shown in Figure 3.5.2.2.2-1.

3.5.2.2.6 CVT STANDOFF PARALLELISM

The CVT Standoff Element shall be parallel to the CDT Backplate as described in Figure 3.5.2.2.2-1.

3.5.2.2.7 CVT STANDOFF ELEMENT ROLL ALIGNMENT

The CVT Standoff Element shall have a roll misalignment about the center of the Backplate as described in Figure 3.5.2.1-1.

3.5.2.2.8 CDT BACKPLATE DEPTH WITHIN VESTIBULE

- A. The CDT shall be mounted within the vestibule such that no part of the Standoff Cross Assembly, including the reflective element, extends past the SCS mating plane.
- B. The CDT shall be mounted such that the center of the front surface of the CDT backplate is no further back from the SCS mating plane than is shown in Figure 3.5.2.2.2-1.

3.5.2.2.9 CVT STANDOFF CROSS VISUAL MARKINGS

The visual markings for the standoff cross shall be as depicted in Figure 3.5.2.2.9-1, Standoff Cross Visual Markings Dimensions.

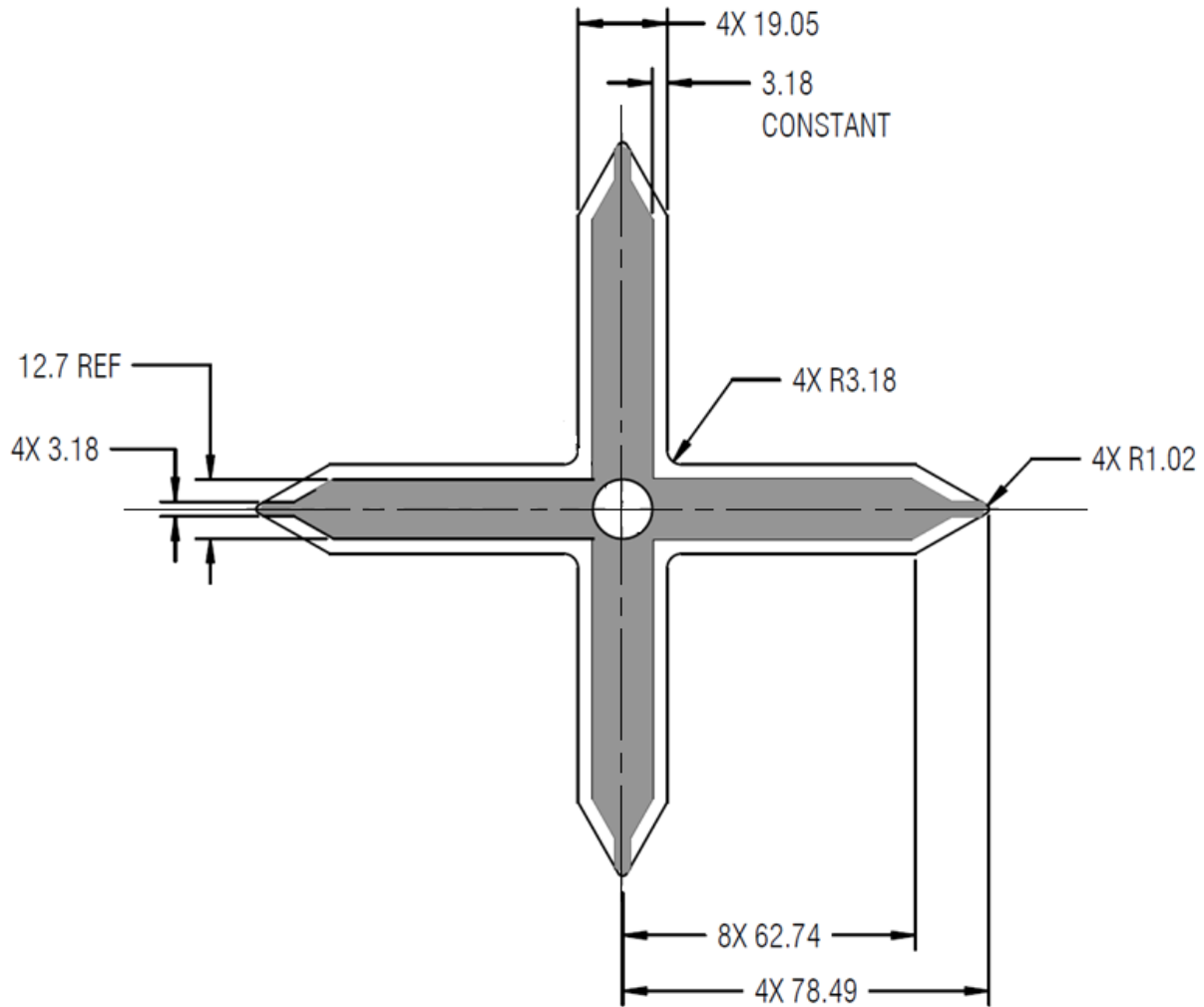

NOTES:

1. Black areas of the target are shown in this figure as gray for clarity.
2. All dimensions in drawing are <TBC 3-4>.

FIGURE 3.5.2.2.9-1 STANDOFF CROSS VISUAL MARKINGS DIMENSIONS

3.5.2.2.10 CVT VISUAL MARKINGS

- A. The visual alignment markings for the CDT backplate shall be as depicted in Figure 3.5.2.2.10-1, CDT Backplate Visual Alignment Markings.
- B. Each quadrant of the CDT backplate shall include a black trapezoidal polygon as depicted in Figure 3.5.2.2.10-2, CDT Backplate Polygon Markings.

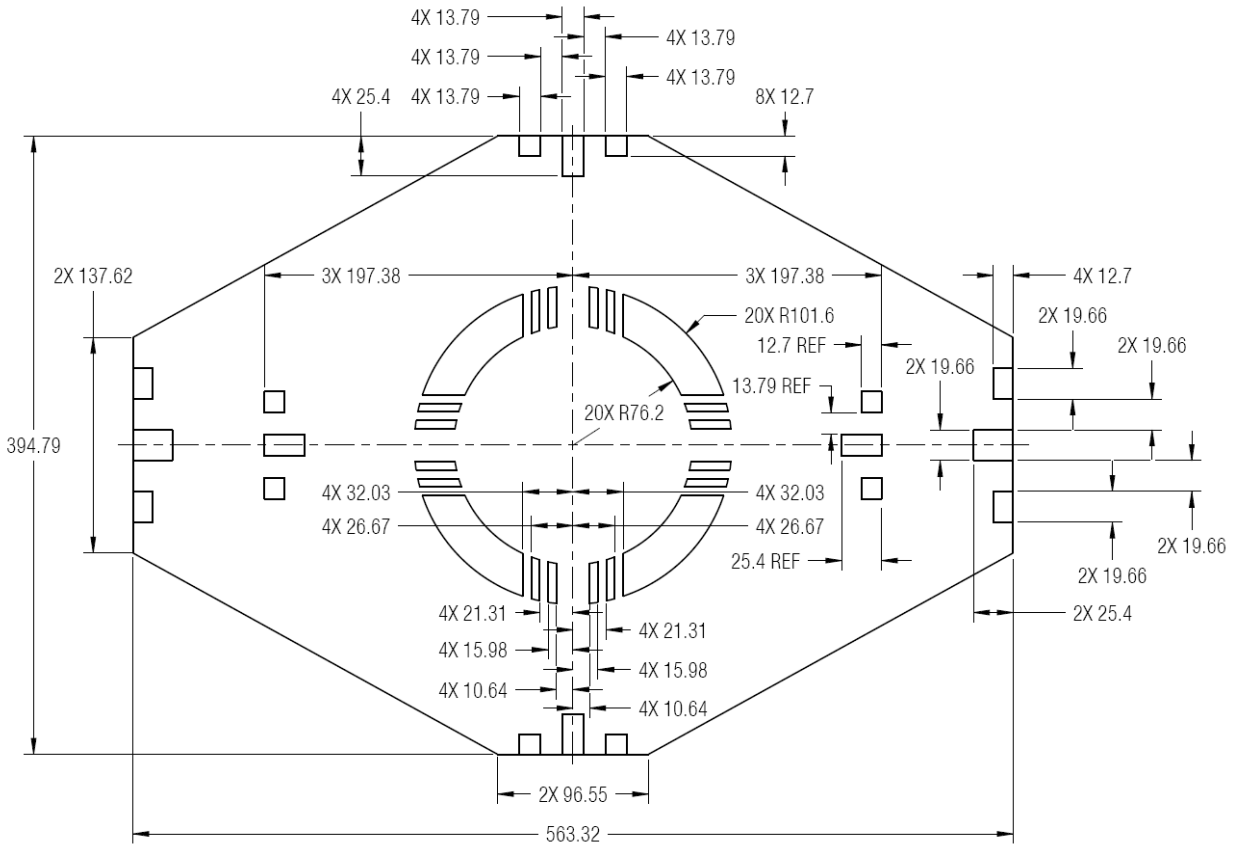

NOTES:

1. Black areas of the target are not shaded in this figure for clarity.
2. All dimensions in drawing are <TBC 3-5>.

FIGURE 3.5.2.2.10-1 CDT BACKPLATE VISUAL ALIGNMENT MARKINGS

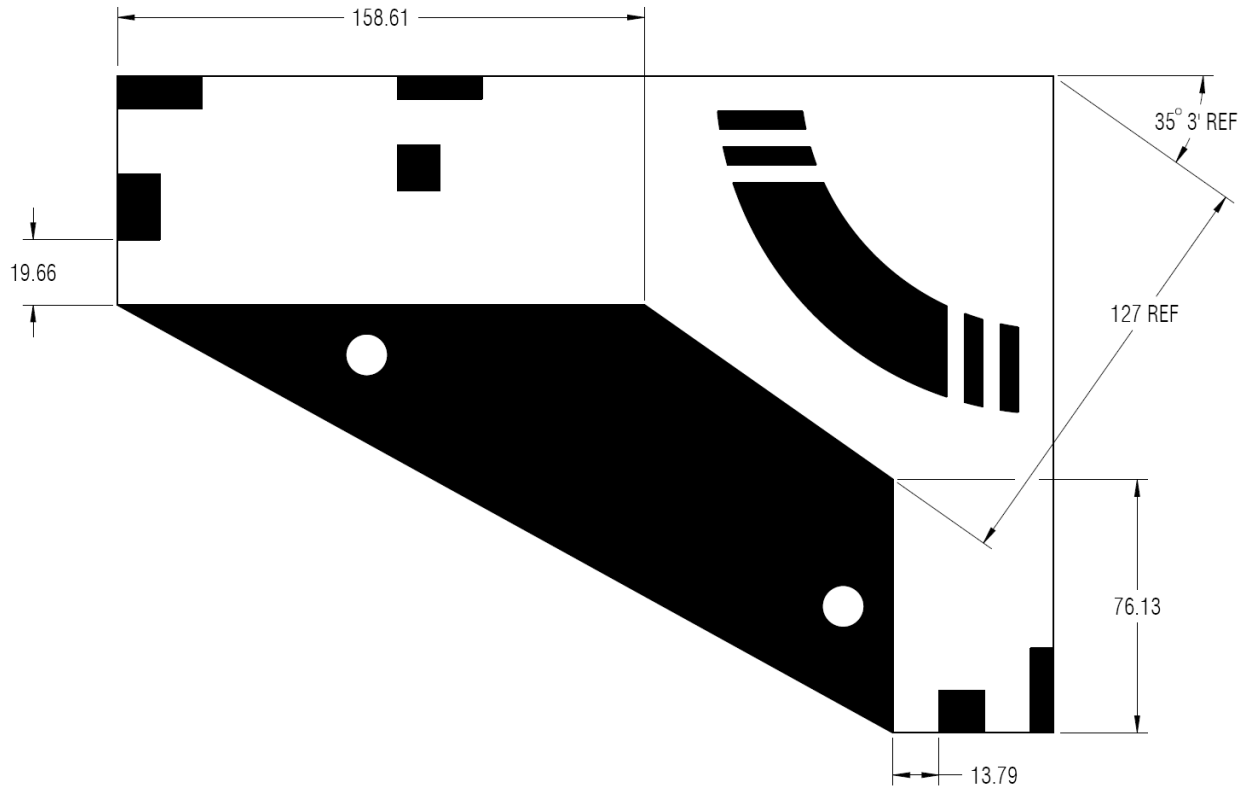

Note: All dimensions in drawing are <TBC 3-5.5>.

FIGURE 3.5.2.2.10-2 CDT BACKPLATE POLYGON MARKINGS

3.5.2.2.11 CVT VISUAL MARKINGS SURFACE

The CVT visual markings surface shall be flat with no raised surfaces/features.

3.5.2.2.12 CVT COLORS <TBR 3-1>

- A. The areas shown as black in Figure 3.5.2.2.9-1, Figure 3.5.2.2.10-1, and Figure 3.5.2.2.10-2 shall have an albedo in the visible spectrum of < 0.1 .
- B. The unshaded areas, except the reflective elements, shown in Figure 3.5.2.2.9-1, Figure 3.5.2.2.10-1, and Figure 3.5.2.2.10-2 shall have an albedo in the visible spectrum of > 0.7 .

3.5.2.2.13 SURFACE REFLECTIVITY <TBR 3-2>

The entire surface of the CDT Backplate, the CRT housings, and the surface of the CVT Standoff Cross shall have a specular reflection of ≤ 15 gloss units according to ASTM D523-14, Standard Test Method for Specular Gloss, or ISO 2813, Paints and Varnishes. Measurement of specular gloss of non-metallic paint films at 20° , 60° and 85° .

3.5.2.3 CENTERLINE REFLECTOR TARGET

The CRT consists of five reflective element and long pass filter subassemblies. Each CRT reflective element shall be comprised of a filter glass and a reflective film/material.

The filter glass material is oriented to the exterior, with the reflective material “protected” by the filter glass. There are four reflective elements attached to the backplate of the CVT, and one out-of-plane element attached to the standoff cross of the CVT.

Filter glass is used to cover the reflective material in the center of the reflective elements. It serves to filter out undesired wavelengths and protects the reflective material from the space environment.

3.5.2.3.1 NUMBER OF CRT REFLECTIVE ELEMENTS

The CRT shall have five (5) reflective elements on the docking target.

3.5.2.3.2 CRT PATTERN

The CRT reflective element pattern is depicted in Figure 3.5.2.3.2-1, Locations of CRT Reflective Elements.

- A. The CRT reflective elements shall be located with respect to the CDT Coordinate System as specified in Table 3.5.2.3.2-1, CRT Reflective Elements Location in CDT Coordinate System. The point of reference is the center of the reflective element on the top surface of the filter glass.
- B. The CRT reflective elements shall have a positional location tolerance of ± 0.3 mm in the y and z axes; and a maximum height of 10 mm above the mounting surface for all reflective elements.
- C. The x-axis location of CRT reflective elements 2, 3, 4, and 5 (as listed in Table 3.5.2.3.2-1) shall differ from each other by ≤ 0.7 mm.

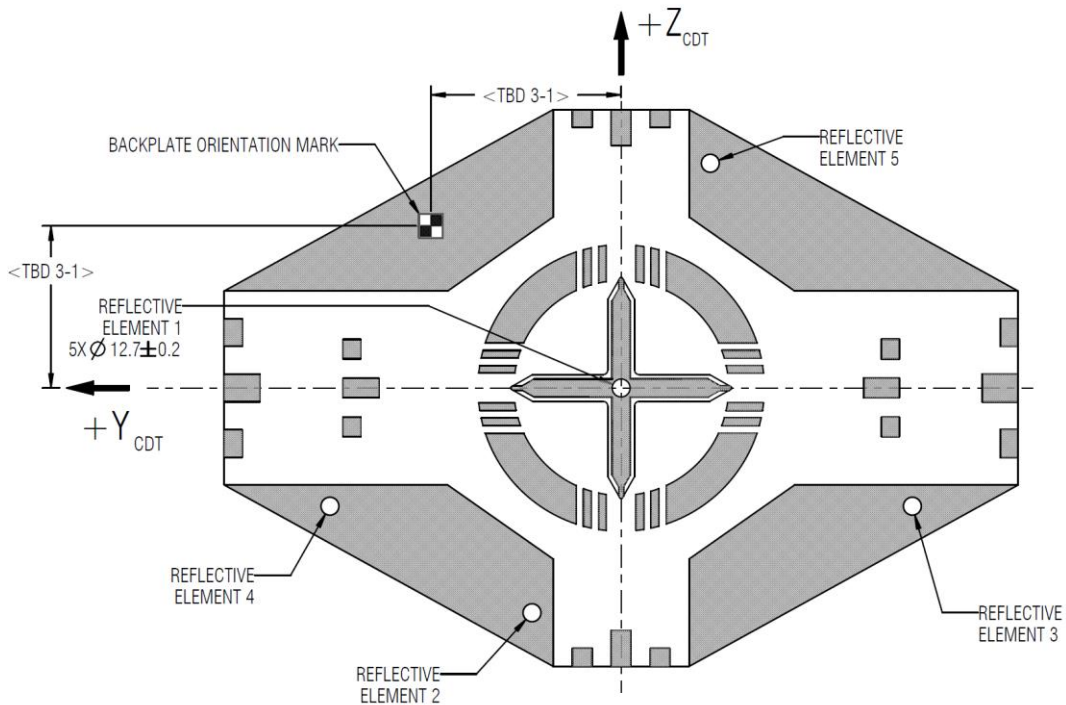

NOTE:

1. Black areas of the target are shown in this figure as gray for clarity.
2. Shape of backplate of target and/or orientation mark is <TBR 3-3>.

FIGURE 3.5.2.3.2-1 LOCATIONS OF CRT REFLECTIVE ELEMENTS

TABLE 3.5.2.3.2-1 CRT REFLECTIVE ELEMENTS LOCATION IN CDT COORDINATE SYSTEM

Reflective Element	X_{CDT}	Y_{CDT}	Z_{CDT}
	mm	mm	mm
1 (standoff)	-304.8	0	0
2	0	63.4	-169.2
3	0	-225.8	-80.0
4	0	226.4	-79.1
5	0	-64.4	168.7

3.5.2.3.3 CRT REFLECTOR SIZING

Each CRT reflective element shall have a clear aperture diameter as shown in Figure 3.5.2.3.2-1, Locations of CRT Reflective Elements.

3.5.2.3.4 CRT FIELD-OF-REGARD OBSCURATION

Each CRT reflective element shall have an unobscured field-of-regard from the top surface of the filter glass of the reflective element originating from the edge of the clear aperture defined in Section 3.5.2.3.3 and shown in Figure 3.5.2.3.4-1.

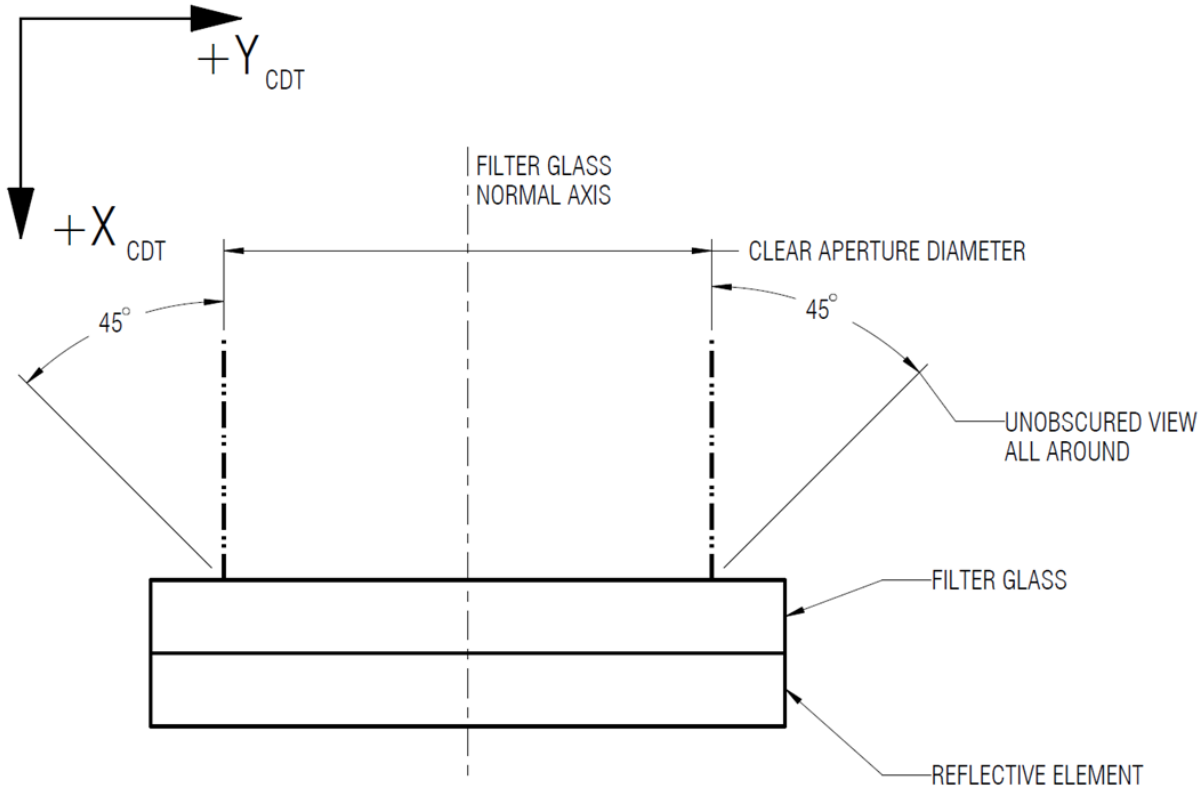

Note: Field-of-regard shown is local to each reflective element, and does not consider surrounding vehicle structure.

FIGURE 3.5.2.3.4-1 CRT UNOBSCURED FIELD-OF-REGARD DEFINITION

3.5.2.3.5 CRT REFLECTIVE ELEMENT MATERIAL PEAK LUMINANCE FACTOR

The CRT reflective element shall have a peak luminance factor of > 2900 .

Note: Luminance factor is defined as the ratio of the luminance of a surface to the luminance of a diffuse white surface.

3.5.2.3.6 CRT REFLECTIVE ELEMENT HALF LUMINANCE ANGLE

The CRT reflective element shall have a half luminance angle of ≥ 25 degrees.

Note: The half luminance angle is the angle with respect to the normal to the reflective element at which the luminance factor is half of its peak value. Luminance factor is defined as the ratio of the luminance of a surface to the luminance of a diffuse white surface.

3.5.2.3.7 CRT REFLECTIVE ELEMENT GAIN

The CRT reflective element shall have a gain of ≥ 2200 .

Note: Gain is defined as the power return from a laser pointing normal to the reflective element normalized by the power return from a laser pointing normal to an ideal Lambertian scatterer.

3.5.2.3.8 CRT REFLECTIVE ELEMENT HALF POWER ANGLE

The CRT reflective element shall have a half power angle of $\geq 0^\circ 15'$ degrees.

Note: The half power angle is defined as the angle with respect to the normal to the reflective element where the returned laser power is half of what it is at the normal.

3.5.2.3.9 CRT REFLECTOR FILTERS

Each CRT reflective element shall have a filter glass to secure the reflective material in place.

3.5.2.3.9.1 REFLECTIVE FILTER OPERATIONAL WAVELENGTH

The total operational wavelength of the filter glass shall include at least the wavelength 380 nm to 1600 nm.

3.5.2.3.9.2 MINIMUM RATE OF TRANSMISSION – OPERATIONAL WAVELENGTH

The minimum rate of transmission in the operational wavelength shall be greater than 80 %/cm for the operational wavelength specified in 3.5.3.9.1.

3.5.2.3.9.3 MAXIMUM RATE OF TRANSMISSION – NON-OPERATIONAL WAVELENGTH

The maximum rate of transmission in the operational wavelength outside the operational wavelength shall be less than 30 %/cm for wavelengths outside of the operational range (less than 380 nm, and greater than 1600 nm).

3.5.3 PERIPHERAL DOCKING TARGET

The Peripheral Docking Target as defined in Figure 3.5.3-1, Peripheral Docking Target, is designed to be compatible with multiple relative navigation sensor technologies: visible cameras, thermal imagers, and lasers. Thus the PDT consists of a Peripheral Visual Target (PVT), Peripheral Infrared Target (PIT), and Short Range Reflector Target (SRRT), with some pieces of hardware serving multiple purposes for the PVT, PIT, or SRRT, as defined in Figure 3.5.3-2, Peripheral Docking Target Components and Functions.

Filter glass is used to cover the reflective material in the center of the circular navigation features. It serves to protect the reflective material from the space environment and to filter out undesired wavelengths.

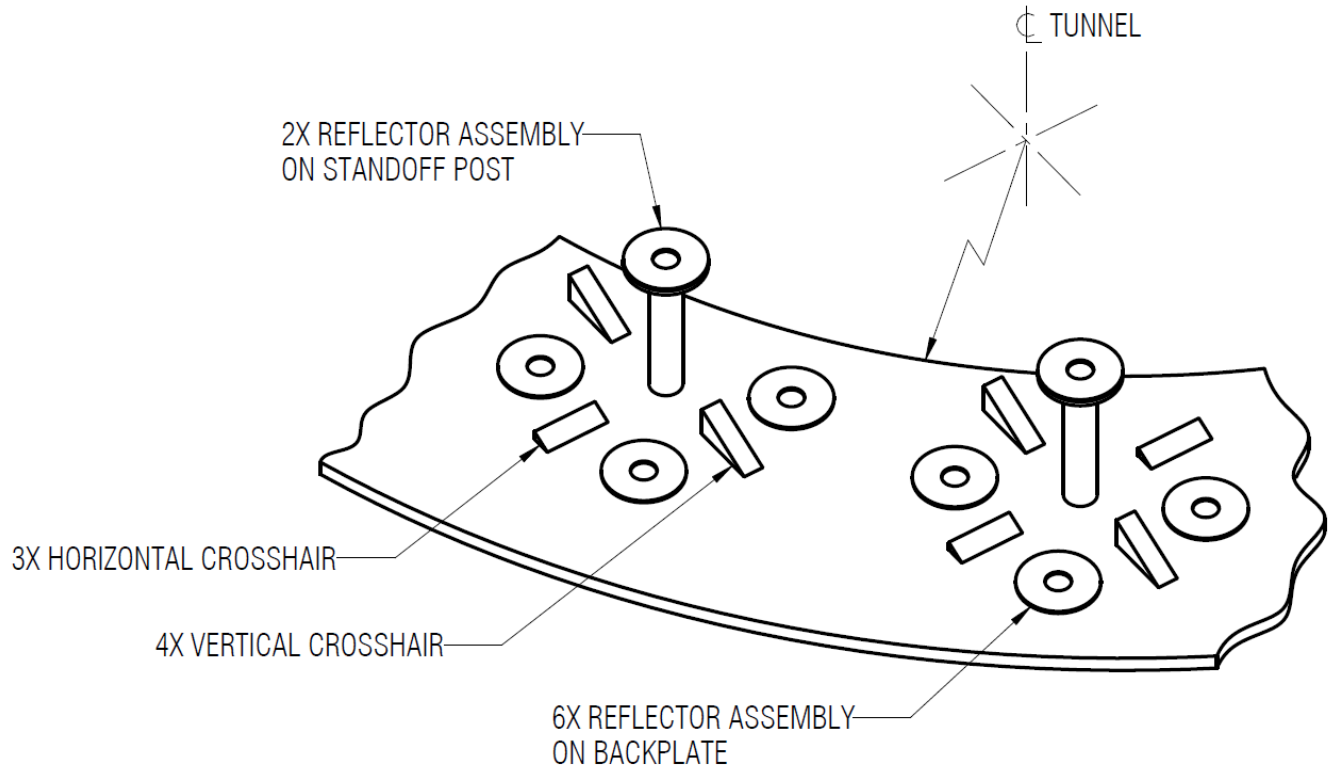
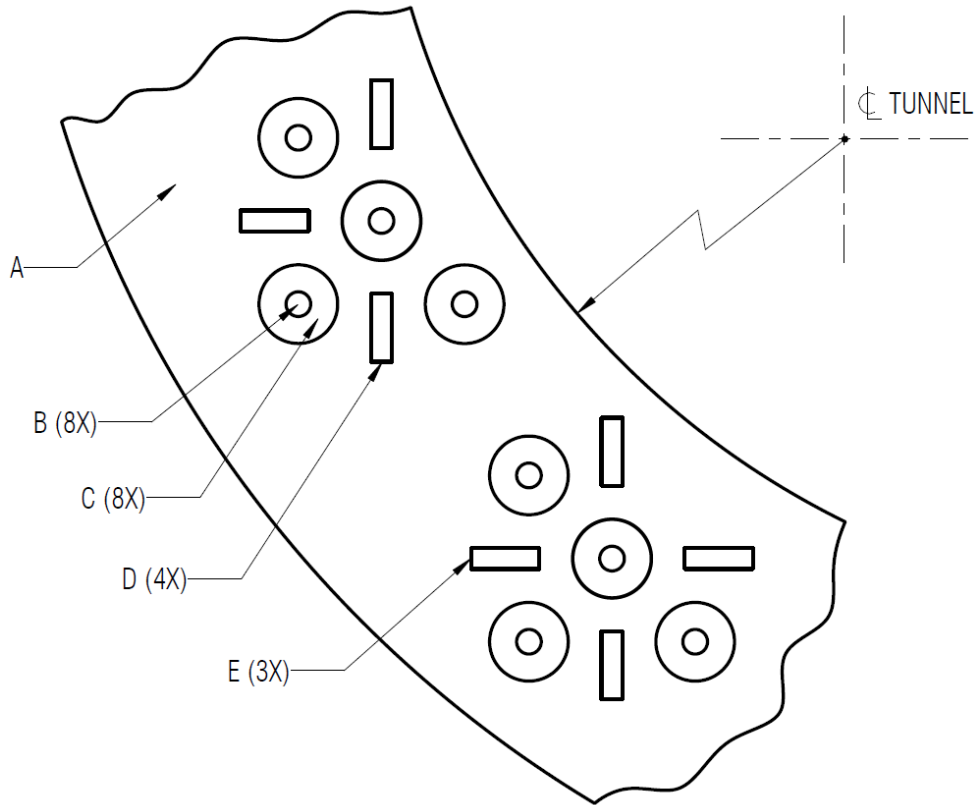

FIGURE 3.5.3-1 PERIPHERAL DOCKING TARGET

(For Reference Only)



Part	Label	PVT	PIT	SRRT
Backplate	A	X	X	
Reflectors	B	X	X	X
Circular Navigation Features	C	X	X	
Vertical Crosshairs	D	X	X	
Horizontal Crosshairs	E	X	X	

FIGURE 3.5.3-2 PERIPHERAL DOCKING TARGET COMPONENTS AND FUNCTIONS

3.5.3.1 PDT COORDINATE SYSTEM FRAMES

Two coordinate systems are used to describe the PDT, as shown in Figure 3.5.3.1-1, PDT Coordinate System Frames.

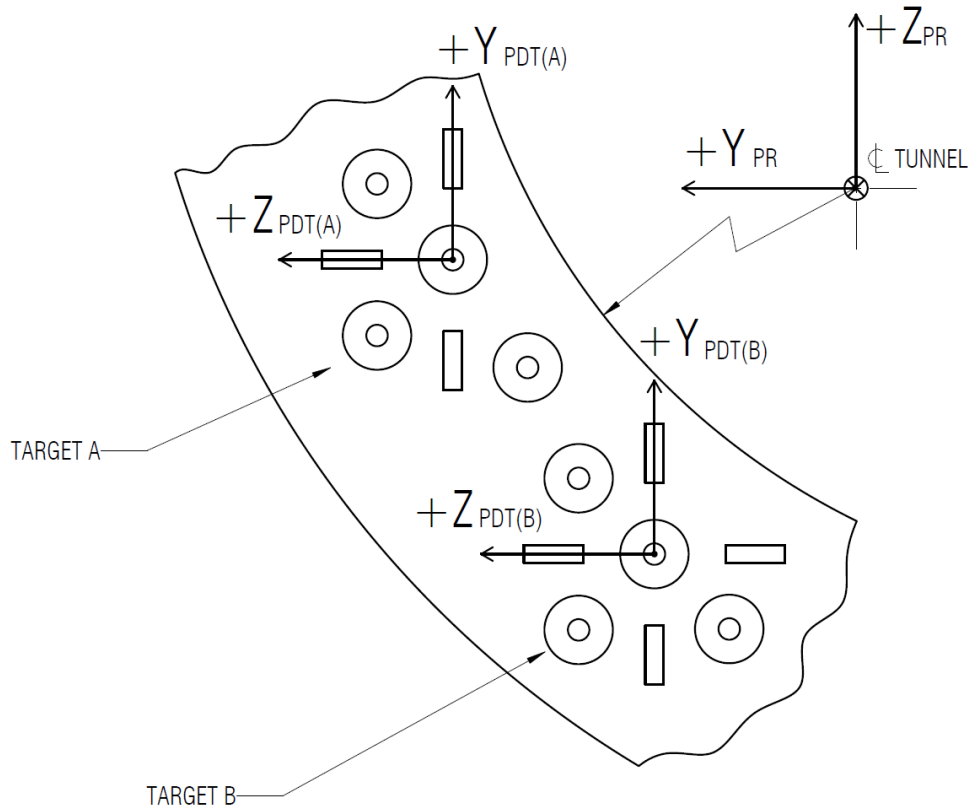

FIGURE 3.5.3.1-1 PDT COORDINATE SYSTEM FRAMES

3.5.3.1.1 TARGET A PDT COORDINATE SYSTEM

The Target A PDT Coordinate System is a right-handed Cartesian coordinate system. Its origin is at the geometric center of the standoff post of the target A PDT at the surface of the backplate facing the active docking vehicle. The coordinate system axis directions are defined as shown in Figure 3.5.3.1-1.

3.5.3.1.2 TARGET B PDT COORDINATE SYSTEM

The Target B PDT Coordinate System is a right-handed Cartesian coordinate system. Its origin is at the geometric center of the standoff post of the target B PDT at the surface of the backplate facing the active docking vehicle. The coordinate system axis directions are defined as shown in Figure 3.5.3.1-1.

3.5.3.2 PERIPHERAL VISUAL TARGET

The Peripheral Visual Target consists of features to provide relative navigation or monitoring cues to a visible light camera. The PVT provides a high-contrast between the backplate and the circles and crosshairs, and another high contrast between the circular navigation features and the filter glass. The surface characteristics of the PVT features are given in sections 3.5.3.24 and 3.5.3.25.

3.5.3.3 PERIPHERAL INFRARED TARGET

The Peripheral Infrared Target consists of features to provide relative navigation or monitoring cues to a thermal imager. The PIT provides a high-thermal-contrast between the backplate and the circles and crosshairs, and another high contrast between the circular navigation features and the filter glass. The backplate and glass have high-emissivity surfaces, and the circular navigation features and crosshairs have low-emissivity surfaces.

3.5.3.4 DEFINITION OF AN INDICATING SURFACE

An Indicating Surface is a surface that is used for dual function as a visual navigation feature for the PVT and as a low-emissivity thermal feature for the PIT. The Circular Navigation Features and the crosshairs contain indicating surfaces. The reflective elements and the glass are not considered indicating surfaces.

3.5.3.5 SHORT RANGE REFLECTOR TARGET

The Short Range Reflector Target consists of assets to provide cues to a relative sensor. The SRRT is designed to provide reflective elements (under filter glass) at known locations on the backplate and standoff.

3.5.3.6 PDT STANDOFF POST POSITIONAL MOUNTING TOLERANCE

The centerline of the Target A and Target B PDT standoff post shall be mounted as shown in Figure 3.5.3.6-1, Location of the PDT Standoff Posts With Respect To the Passive SCS Ring Coordinate System.

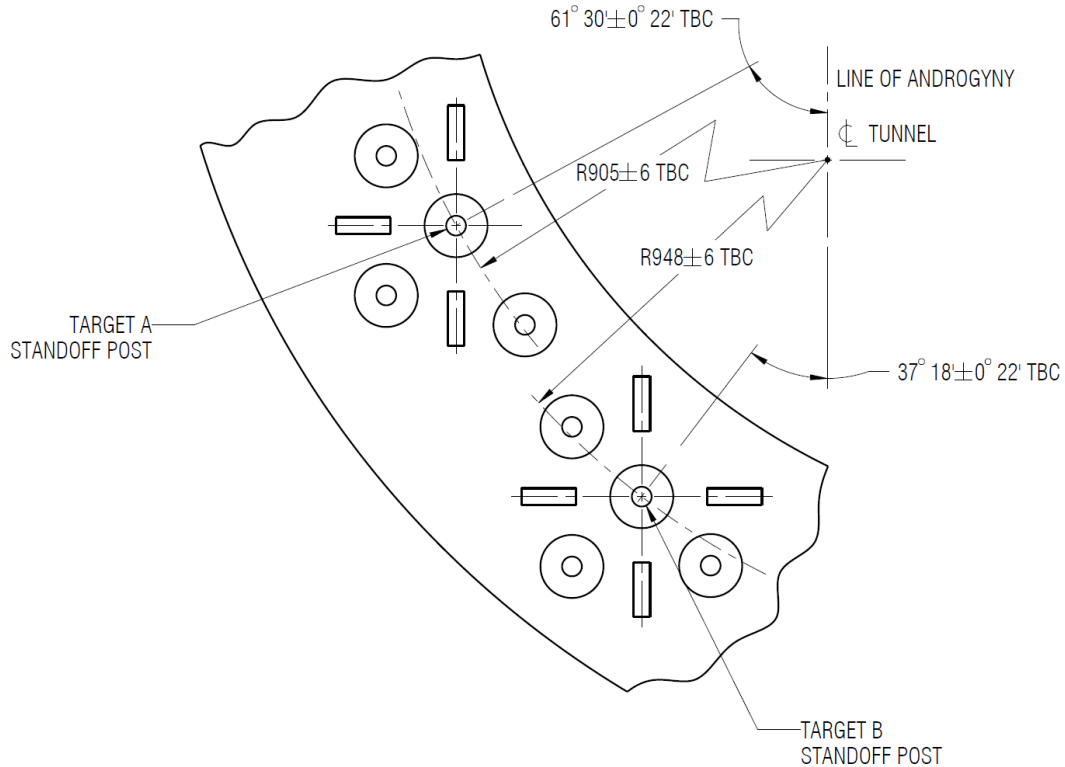

Note: After installation, the uncertainty in the pre-flight measured radial location of key target features with respect to the SCS Passive Ring (PR) coordinate frame shall not exceed 1 mm.

FIGURE 3.5.3.6-1 LOCATION OF THE PDT STANDOFF POSTS WITH RESPECT TO THE PASSIVE SCS RING COORDINATE SYSTEM

3.5.3.7 PVT STANDOFF POSTS

The PVT shall have two standoff posts.

3.5.3.7.1 PVT STANDOFF CIRCLE POSITIONAL MISALIGNMENT

Each PVT standoff circle shall have a positional misalignment with respect to the local PDT coordinate system $\leq \pm 1$ mm within the y-z plane from the origin of the local PDT Coordinate System.

3.5.3.7.2 PVT STANDOFF CIRCLE ANGULAR MISALIGNMENT

Each PVT standoff circle shall have an angular misalignment with respect to the local PDT coordinate system $\leq \pm 1.0$ degree in wobble (RSS of pitch and yaw).

Note: As viewed from a camera, there should be no perceptible foreshortening of the standoff circle when viewed from a direction normal to backplate.

3.5.3.8 PVT VISUAL NAVIGATION FEATURES PLACEMENT

- A. The circular navigation features shall be located as shown in Figure 3.5.3.8-1, Circular Navigation Feature Locations.

B. There shall be at least 32 mm of backplate between the edge of any circular visual navigation feature and the edge of the backplate.

Note: A minimum border around each visual navigation feature must be maintained even in the presence of transition areas from light to dark where the raised backplate features meet the backplate.

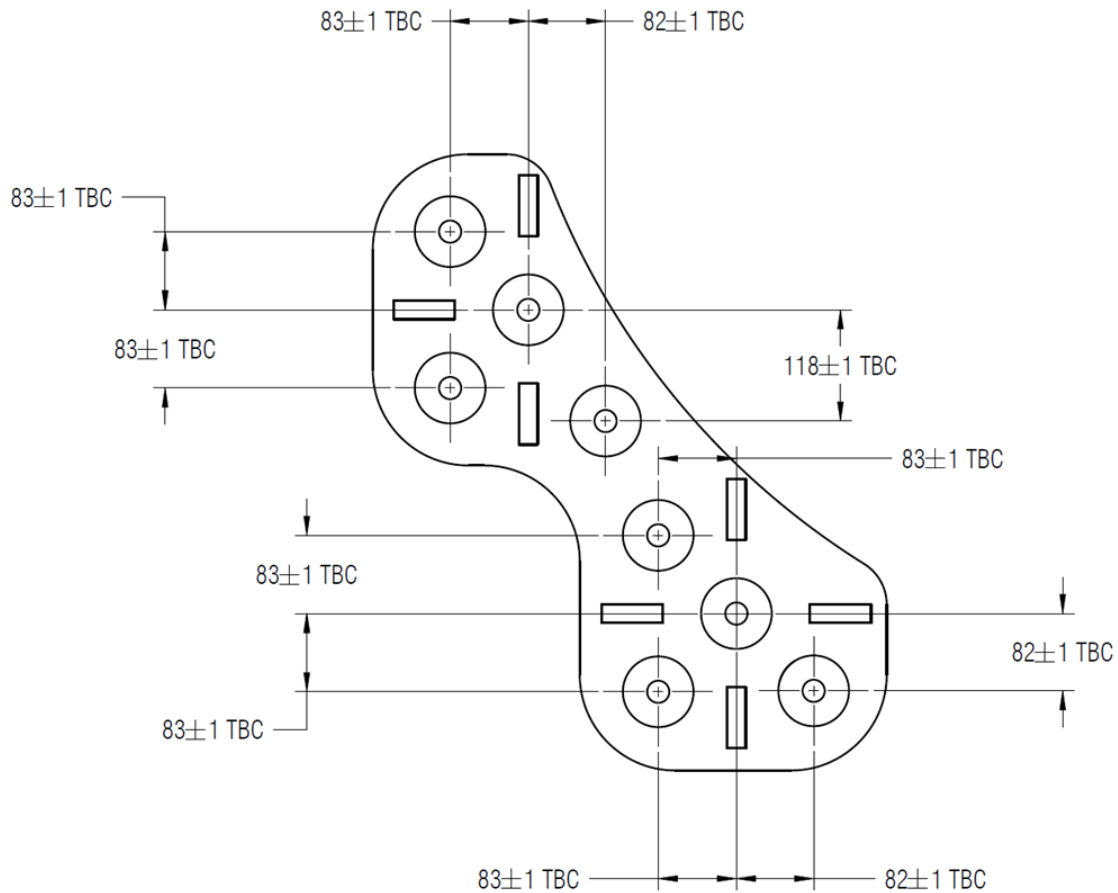

FIGURE 3.5.3.8-1 CIRCULAR NAVIGATION FEATURE LOCATIONS

3.5.3.9 PVT CIRCULAR NAVIGATION FEATURE INDICATING SURFACE OUTER DIAMETER

The outer diameter of the indicating surface of each circular navigation feature on the PVT backplate and the standoff post shall have a diameter as shown in Figure 3.5.3.9-1, Circular Navigation Feature Details.

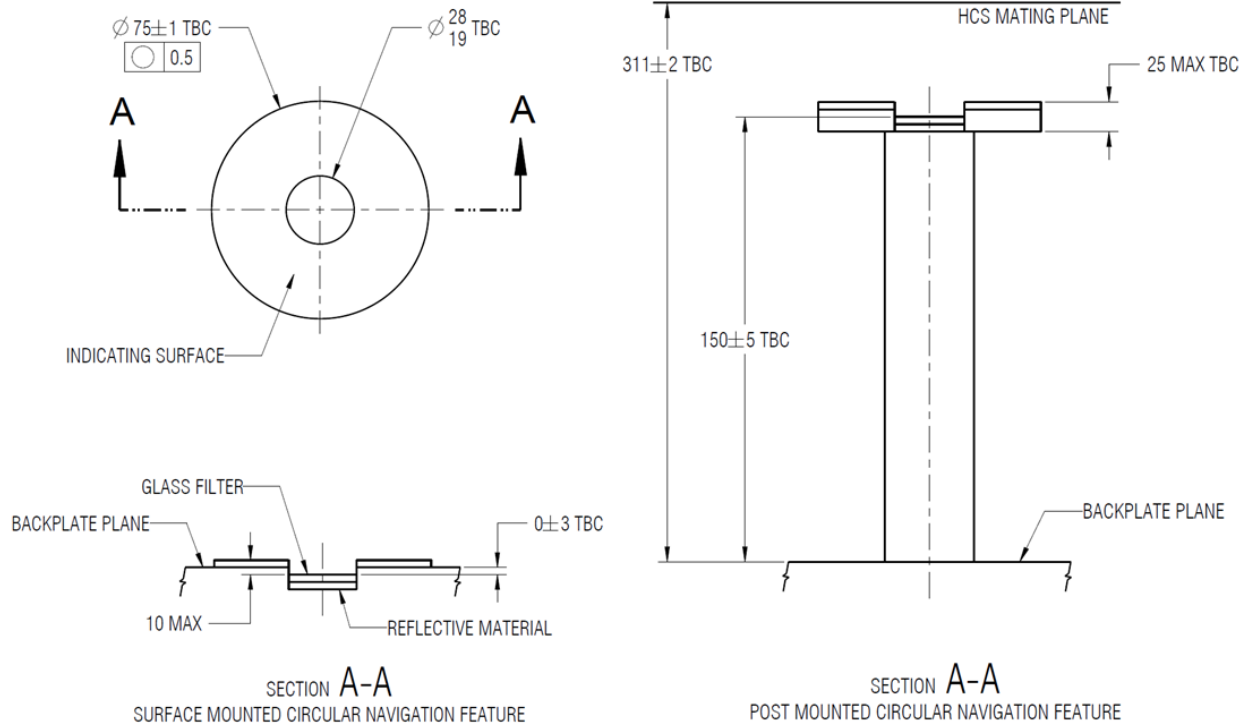

FIGURE 3.5.3.9-1 CIRCULAR NAVIGATION FEATURE DETAILS

3.5.3.10 PVT CIRCULAR NAVIGATION FEATURE INDICATING SURFACE INNER DIAMETER

The inner diameter of the indicating Surface of each circular navigation feature on the PVT backplate and the standoff post shall have a diameter as shown in Figure 3.5.3.9-1.

3.5.3.11 PVT CIRCULAR NAVIGATION FEATURE INNER DIAMETER CONCENTRICITY

The inner diameter of each circular navigation feature on the PVT backplate and the standoff post shall be concentric with respect to the outer diameter with a circular deviation ≤ 0.76 mm.

3.5.3.12 PVT STANDOFF CIRCULAR NAVIGATION FEATURE THICKNESS

The circular navigation feature on each standoff post shall have a thickness from the PDT +X surface of the circular navigation feature to the PDT -X surface of the circular navigation feature as shown in Figure 3.5.3.9-1.

Note: There is no need for tight control on the thickness of the standoff circular navigation feature.

3.5.3.13 PVT CIRCULAR NAVIGATION FEATURE DEPTH

Each circular navigation feature shall be placed such that the distance between the center of the filter glass at the PDT +X (active docking vehicle-facing) surface and the PDT Y-Z plane is as shown in Figure 3.5.3.9-1.

3.5.3.14 PVT CIRCULAR NAVIGATION FEATURE TRANSITION

The transition and circularity between Indicating Surfaces of the PVT and the backplate shall be as shown in Figure 3.5.3.9-1.

3.5.3.15 PVT CIRCULAR NAVIGATION FEATURE MAXIMUM RADIUS OF THE EDGES

The edges of the circular navigation features shall have a maximum radius of 2 mm <TBC 3-11>.

3.5.3.16 PVT CROSSHAIR LENGTH

The indicating surface of the crosshairs on the PVT backplate shall have a length as shown in Figure 3.5.3.16-1, PDT Crosshair Details.

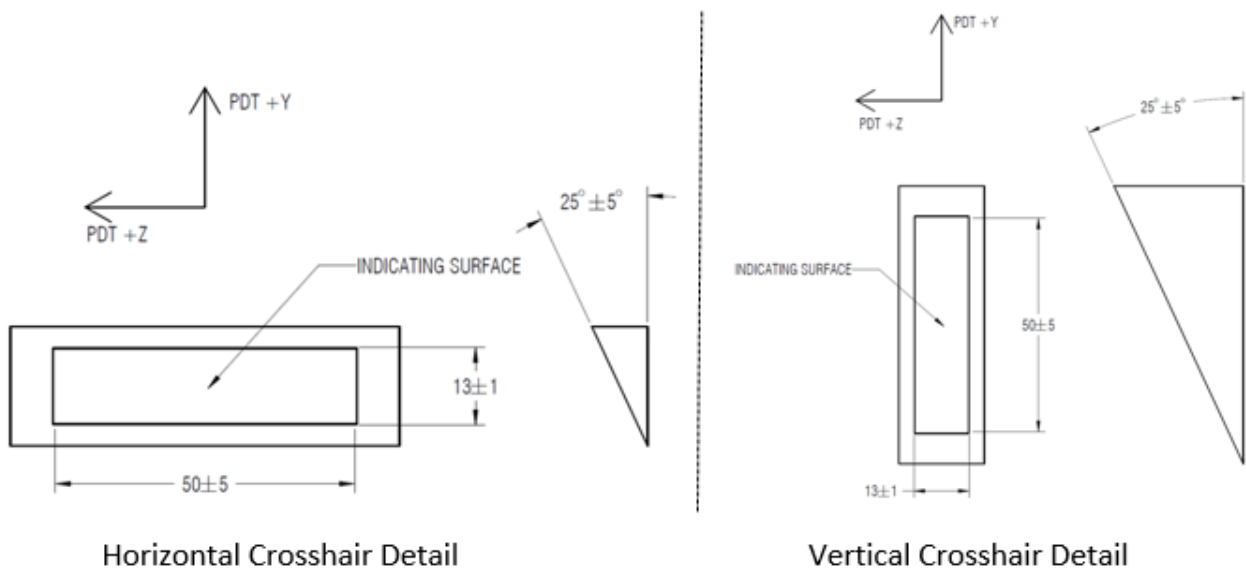

Maximum radius of the edges = 2 mm <TBC 3-12>

FIGURE 3.5.3.16-1 PDT CROSSHAIR DETAILS

3.5.3.17 PVT CROSSHAIR WIDTH

The indicating surface of the crosshairs on the PVT backplate shall have a width as shown in Figure 3.5.3.16-1.

3.5.3.18 PVT CROSSHAIR PLACEMENT

The crosshairs shall be placed on the PVT backplate as shown in Figure 3.5.3.18-1, PVT Crosshair Locations.

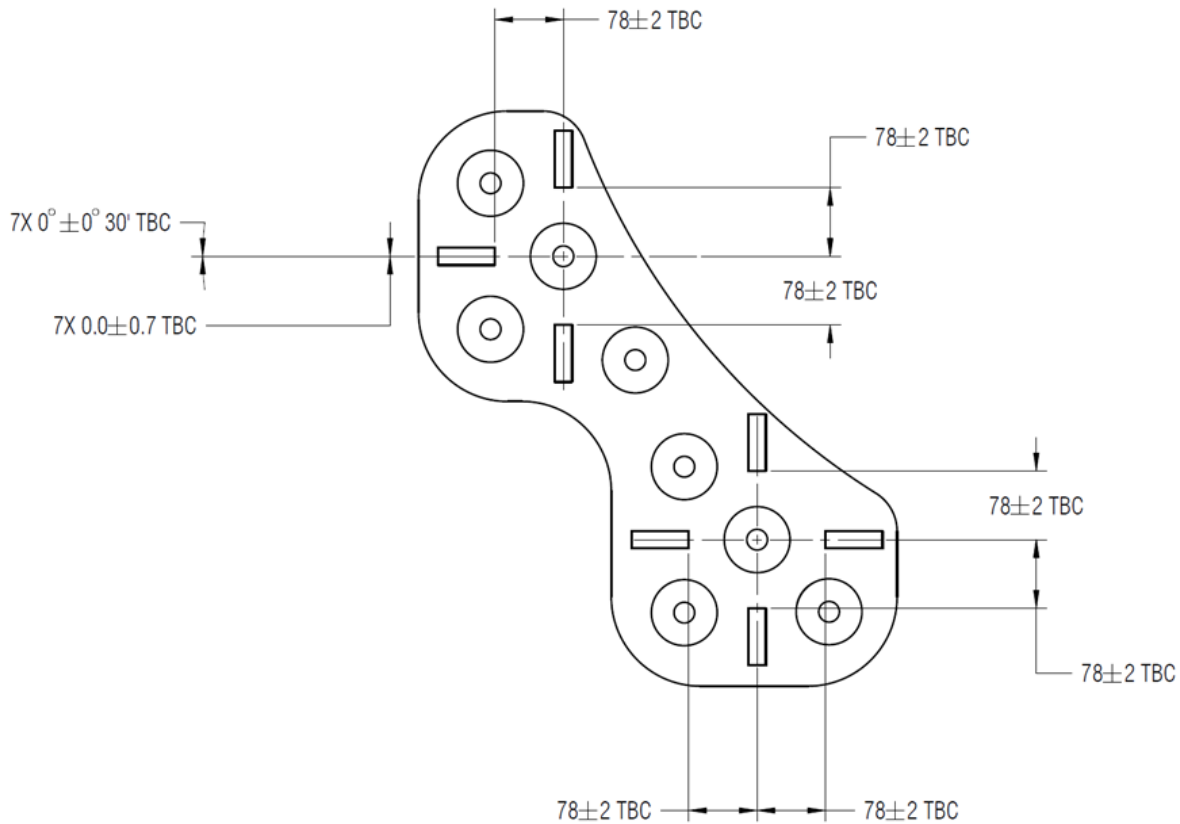

FIGURE 3.5.3.18-1 PVT CROSSHAIR LOCATIONS

3.5.3.19 PVT CROSSHAIR ALIGNMENT

The crosshairs shall be placed on the PVT backplate such that the longitudinal centerline is aligned with respect to a principal axis in the PDT coordinate system as shown in Figure 3.5.3.18-1.

3.5.3.20 INDICATING SURFACE CONTINUITY

The Indicating Surfaces of the circular navigation features and crosshairs shall be uninterrupted.

3.5.3.21 SHORT RANGE REFLECTOR TARGET REQUIREMENTS

The reflective elements are used by an active vehicle's laser sensor to provide relative measurements to the vehicle's navigation system. The SRRT reflectors shall be placed inside the circular navigation features, such that the reflective material is visible through their inner diameter. Each SRRT Reflective Element shall be comprised of a filter glass and reflective film/material. The filter glass material is oriented to exterior, with reflective material "protected" by the filter glass.

3.5.3.21.1 NUMBER OF SRRT REFLECTIVE ELEMENTS

The SRRT shall have eight (8) reflective elements on the docking target.

3.5.3.21.2 SRRT REFLECTIVE ELEMENT MATERIAL PEAK LUMINANCE FACTOR

The SRRT reflective element shall have a peak luminance factor > 2900 .

Note: Luminance factor is defined as the ratio of the luminance of a surface to the luminance of a diffuse white surface.

3.5.3.21.3 SRRT REFLECTIVE ELEMENT HALF LUMINANCE ANGLE

The SRRT reflective element shall have a half luminance angle ≥ 25 degrees.

Note: The half luminance angle is the angle with respect to the normal to the reflective element at which the luminance factor is half of its peak value. Luminance factor is defined as the ratio of the luminance of a surface to the luminance of a diffuse white surface.

3.5.3.21.4 SRRT REFLECTIVE ELEMENT GAIN

The SRRT reflective element shall have a gain ≥ 2200 .

Note: Gain is defined as the power return from a laser pointing normal to the reflective element normalized by the power return from a laser pointing normal to an ideal Lambertian scatterer.

3.5.3.21.5 SRRT REFLECTIVE ELEMENT HALF POWER ANGLE

The SRRT reflective element shall have a half power angle ≥ 0.25 degrees.

Note: The half power angle is defined as the angle with respect to the normal to the reflective element where the returned laser power is half of what it is at the normal.

3.5.3.21.6 SRRT REFLECTIVE ELEMENT LOCATION

An SRRT reflective element shall be located within the inner diameter of each circular navigation feature such that it is visible through the aperture of the inner diameter.

Note: The reflective elements should share a centroid with the circular navigation features.

3.5.3.21.7 SRRT FIELD-OF-REGARD OBSCURATION

Each SRRT reflective element shall have an unobscured field-of-regard from the top surface of the filter glass originating from the edge of the clear aperture defined by the inner diameter in Paragraph 3.5.3.10 and shown in Figure 3.5.3.21.7-1, SRRT Unobscured Field-of-Regard Definition.

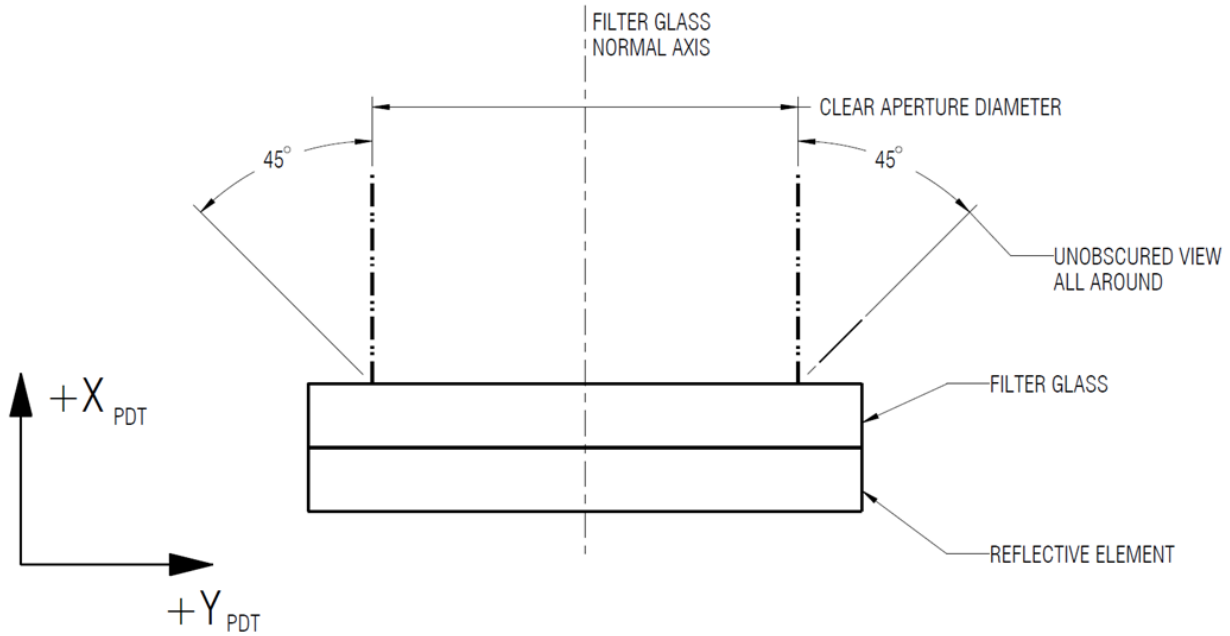

Note:

1. The normal axis of the filter glass shall be parallel to the X-Axis of the local Target A or Target B PDT coordinate system within $\pm 5^\circ$.
2. Field-of-regard shown is local to each reflective element, and does not consider surrounding vehicle structure.

FIGURE 3.5.3.21.7-1 SRRT UNOBSCURED FIELD-OF-REGARD DEFINITION

3.5.3.21.8 SRRT REFLECTOR FILTERS

Each SRRT reflective element shall have a filter glass cover to secure the reflective material in place.

3.5.3.21.8.1 REFLECTIVE FILTER OPERATIONAL WAVELENGTH

The total operational wavelength of the filter glass shall include at least the wavelength 380 nm to 1600 nm.

3.5.3.21.8.2 MINIMUM RATE OF TRANSMISSION – OPERATIONAL WAVELENGTH

The minimum rate of transmission in the operational wavelength shall be greater than 80 %/cm for the operational wavelength specified in 3.5.3.21.8.1.

3.5.3.21.8.3 MAXIMUM RATE OF TRANSMISSION – NON-OPERATIONAL WAVELENGTH

The maximum rate of transmission in the operational wavelength outside the operational wavelength shall be less than 30 %/cm for wavelengths outside of the operational range (less than 380 nm, and greater than 1600 nm).

3.5.3.21.9 SRRT REFLECTOR FILTERS MISALIGNMENT

Each SRRT filter cover shall be perpendicular to the x-axis of the local Target A or Target B PDT coordinate system as shown in Figure 3.5.3.21.7-1.

3.5.3.21.10 SRRT OUT-OF-PLANE REFLECTIVE ELEMENT

The SRRT shall have one reflective element on each of the two (2) standoff posts.

3.5.3.22 PERIPHERAL INFRARED TARGET REQUIREMENTS

The PIT will provide infrared markings to allow the active docking vehicle relative navigation system to determine the lateral offset, and the pitch, yaw, and roll relative to the centerline of soft capture interface plane using a thermal imager.

The indicating surface of the crosshairs shall be angled towards the PDT -Y direction with respect to the PDT Y-Z plane, as shown in Figure 3.5.3.16-1.

3.5.3.23 PDT STANDOFF ELEMENT HEIGHT

The PDT shall have a standoff element as shown in Figure 3.5.3.9-1 extending from the local PDT coordinate system y-z plane to the surface of the filter glass covering the reflective element.

3.5.3.24 PIT/PVT SURFACE CHARACTERISTICS <TBR 3-4>

All indicating surfaces and the PDT +X (active docking vehicle-facing) surface of the backplate shall have the solar absorptance (according to ASTM E903-12, Standard Test Method for Solar Absorptance, Reflectance, and Transmittance of Materials Using Integrated Spheres) and thermal emittance (according to ASTM E408-13, Standard Test Methods for Total Normal Emittance of Surfaces Using Inspection-Meter Techniques) values and contrasts as follows:

Crosshairs and circular navigation features:

- A. solar absorptance ≥ 0.85
- B. emittance contrast with respect to backplate $\Delta \geq 0.3$

Backplate:

- A. solar absorptance contrast with respect to crosshairs and circular navigation features $\Delta \geq 0.6$

Reflective Element with Glass <TBD 3-3>

3.5.3.25 SURFACE GLOSSINESS <TBR 3-5>

All indicating surfaces and the PDT +X (active docking vehicle-facing) surface of the backplate shall have a specular reflection ≤ 45 gloss units according to ASTM D523-14 or ISO 2813.

APPENDIX A - ACRONYMS AND ABBREVIATIONS

APAS	Androgynous Peripheral Assembly System
C	Celsius
CDT	Centerline Docking Target
CG	Center of Gravity
CRT	Centerline Reflector Target
CSA	Canadian Space Agency
CVT	Centerline Visual Target
DC	Direct Current
deg	degree
DOF	Degree of Freedom
EMA	Electro-Mechanical Actuator
ESA	European Space Agency
F	Fahrenheit
FOR	Field Of Regard
FRAM	Flight Releasable Attachment Mechanism
GN&C	Guidance Navigation and Control
HCS	Hard Capture System
hPa	Hecto Pascal(s)
IDD	Interface Definition Document
IDSS	International Docking System Standard
IEEE	Institute of Electrical and Electronic Engineers
ISS	International Space Station
kg	kilogram
kgf	kilograms force
KOZ	Keep Out Zone
LEO	Low Earth Orbit
m	meters
MAX	Maximum
MCB	Multilateral Control Board
MEXT	Ministry of Education, Culture, Sports, Science and Technology – Japan
MIL	Military
MIN	Minimum
mm	Millimeters
MOI	Moments of inertia
N	Newton(s)

IDSS IDD Revision D
April 30, 2015

NASA	National Aeronautics and Space Administration
NDS	NASA Docking System
nm	nanometers
Nm	Newton-Meter(s)
ODS	Orbiter Docking System
ohm	Ohms
Pa	Pascal
PDT	Peripheral Docking Target
PDTU	Power/Data Transfer Umbilical
PIT	Peripheral Infrared Target
POI	Products of inertia
PR	Passive Ring
PRT	Perimeter Reflector Target
PVT	Peripheral Visual Target
R	Radius
RECP	Receptacle
REF	Reference
RF	Radio Frequency
RMS	Root Mean Square
RSS	Root Sum Square
RX	Receive
SCS	Soft Capture System
sec	second
SRRT	Short Range Reflector Target
SSRMS	Space Station Remote Manipulator System
STD	Standard
Sys	System
TBC	To Be Confirmed
TBD	To Be Determined
TBS	To Be Supplied
THK	Thick
tonne	metric ton = 1000 kilograms
TX	Transmit
VDC	Volts Direct Current

APPENDIX B – GLOSSARY <RESERVED>

APPENDIX C - OPEN WORK

Table C-1 lists the specific To Be Determined (TBD) items in the document that are not yet known. The TBD is inserted as a placeholder wherever the required data is needed and is formatted in bold type within brackets. The TBD item is numbered based on the section where the first occurrence of the item is located as the first digit and a consecutive number as the second digit (i.e., <TBD 4-1> is the first undetermined item assigned in Section 4 of the document). As each TBD is solved, the updated text is inserted in each place that the TBD appears in the document and the item is removed from this table. As new TBD items are assigned, they will be added to this list in accordance with the above described numbering scheme. Original TBDs will not be renumbered.

TABLE C-1 TO BE DETERMINED ITEMS

TBD	Section	Description
<TBC 3-1>	3.2.4.1	Value to be confirmed.
<TBC 3-2>	Figure 3.5.2.1-1	angular tolerance $\pm 0^{\circ}6'$ to be confirmed; roll tolerance of $\pm 0^{\circ}15'$ to be confirmed
<TBC 3-3>	Figure 3.5.2.2.2-1	1100 MAX dimension to be confirmed; 0 ± 1.3 all directions with respect to backplate center to be confirmed; 0 ± 6.3 all directions with respect to passive SCS ring X-axis to be confirmed; angular tolerance of $\pm 0^{\circ}01'30''$ to be confirmed
<TBC 3-4>	Figure 3.5.2.2.9-1	all dimensions in drawing are to be confirmed.
<TBC 3-5>	Figure 3.5.2.2.10-1	all dimensions in drawing are to be confirmed.
<TBC 3-5.5>	Figure 3.5.2.2.10-2	all dimensions in drawing are to be confirmed.
<TBC 3-6>	Figure 3.5.1.1-1	$141^{\circ}48'$; 44° ; $80^{\circ}30'$; dia.2235.2 are all to be confirmed.
<TBC 3-7>	Figure 3.5.1.1.4-1	277 distance is to be confirmed.
<TBC 3-8>	Figure 3.5.3.6-1	$61^{\circ}30' \pm 0^{\circ}22'$, $R905 \pm 6$, $R948 \pm 6$, $37^{\circ}18' \pm 0^{\circ}22'$ are to be confirmed.
<TBC 3-9>	Figure 3.5.3.8-1	83 ± 1 , 82 ± 1 , 118 ± 1 dimensions are all to be confirmed.
<TBC 3-10>	Figure 3.5.3.9-1	Diameter 75 ± 1 , diameter 28/19, 0 ± 3 , 311 ± 2 , 150 ± 5 , 25 MAX are to be confirmed.
<TBC 3-11>	3.5.3.15	Maximum radius of 2 mm is to be confirmed.
<TBC 3-12>	Figure 3.5.3.16-1	Maximum edges of the radius of 2 mm is to be confirmed.
<TBC 3-13>	Figure 3.5.3.18-1	78 ± 2 , $7 \times 0^{\circ} \pm 0^{\circ}30'$, $7 \times 0.0 \pm 0.7$ are to be confirmed.
<TBD 3-1>	Figure 3.5.2.3.2-1	dimension from the +Z _{CDT} axis to the backplate orientation mark is to be determined; dimension from the +Y _{CDT} axis to the backplate orientation mark is to be determined
<TBD 3-3>	3.5.3.24	Reflective element with glass to be determined.

IDSS IDD Revision D
April 30, 2015

Table C-2 lists the specific To Be Resolved (TBR) issues in the document that are not yet known. The TBR is inserted as a placeholder wherever the required data is needed and is formatted in bold type within brackets. The TBR issue is numbered based on the section where the first occurrence of the issue is located as the first digit and a consecutive number as the second digit (i.e., <TBR 4-1> is the first unresolved issue assigned in Section 4 of the document). As each TBR is resolved, the updated text is inserted in each place that the TBR appears in the document and the issue is removed from this table. As new TBR issues are assigned, they will be added to this list in accordance with the above described numbering scheme. Original TBRs will not be renumbered.

TABLE C-2 TO BE RESOLVED ISSUES

TBR	Section	Description
<TBR 3-1>	3.5.2.2.12	CVT colors section is to be resolved
<TBR 3-2>	3.5.2.2.13	Surface reflectivity section is to be resolved
<TBR 3-3>	Figure 3.5.2.3.2-1	Shape of bottom portion of target and/or orientation mark is to be resolved
<TBR 3-4>	3.5.3.24	Surface characteristics to be resolved.
<TBR 3-5>	3.5.3.25	Surface glossiness to be resolved.
<TBS 3-1>	3.5.1.2	Reflector characteristics to be supplied.

APPENDIX D – HARD CAPTURE SYSTEM HERITAGE STRIKER ZONES

To maintain simplicity for the standard, a set of generic zones, called the HCS Component Striker Zones, are defined on the HCS mating flange (shown in Figure 3.2.3-1) as striker zones for various peripheral components and sensors. These zones are the passive flat surface that a docking system designer may choose to use as striker areas for the corresponding devices.

The HCS Component Striker Zones are nine identical segments around the circumference of the HCS. A reference numbering scheme for the segments is shown in Figure D-1, HCS Component Striker Zone Reference Numbers. Each segment consists of a Free Area and a Reserved Area.

For both the Free Area and the Reserved Area, the striker area is a flat surface with a few local exceptions. These exceptions are various small holes used for the underlying subsystems (such as attach points for the Latching System), and for other purposes. Many times, these small holes will not interfere with the striking device. The details of these small holes and other features are provided herein for a designer to consider when utilizing the striker zone.

In the Free Area, the same small exceptions occur repeatedly, and these features should be easier to work around to place striking components. The Reserved Area is where legacy systems, such as APAS or NDS, have already located components which will be difficult to work around in some locations, and the use of these areas will require careful, detailed coordination with those designs to assure no interference. These features within the striker zones are shown in Figure D-2, APAS Features within Striker Zones, and Figure D-3, NDS Features within Striker Zones.

In summary, using the Free Areas is recommended, though the locations of some small holes must be considered. Using the Reserved Areas will require collaboration with the relevant legacy system and/or mission specific information.

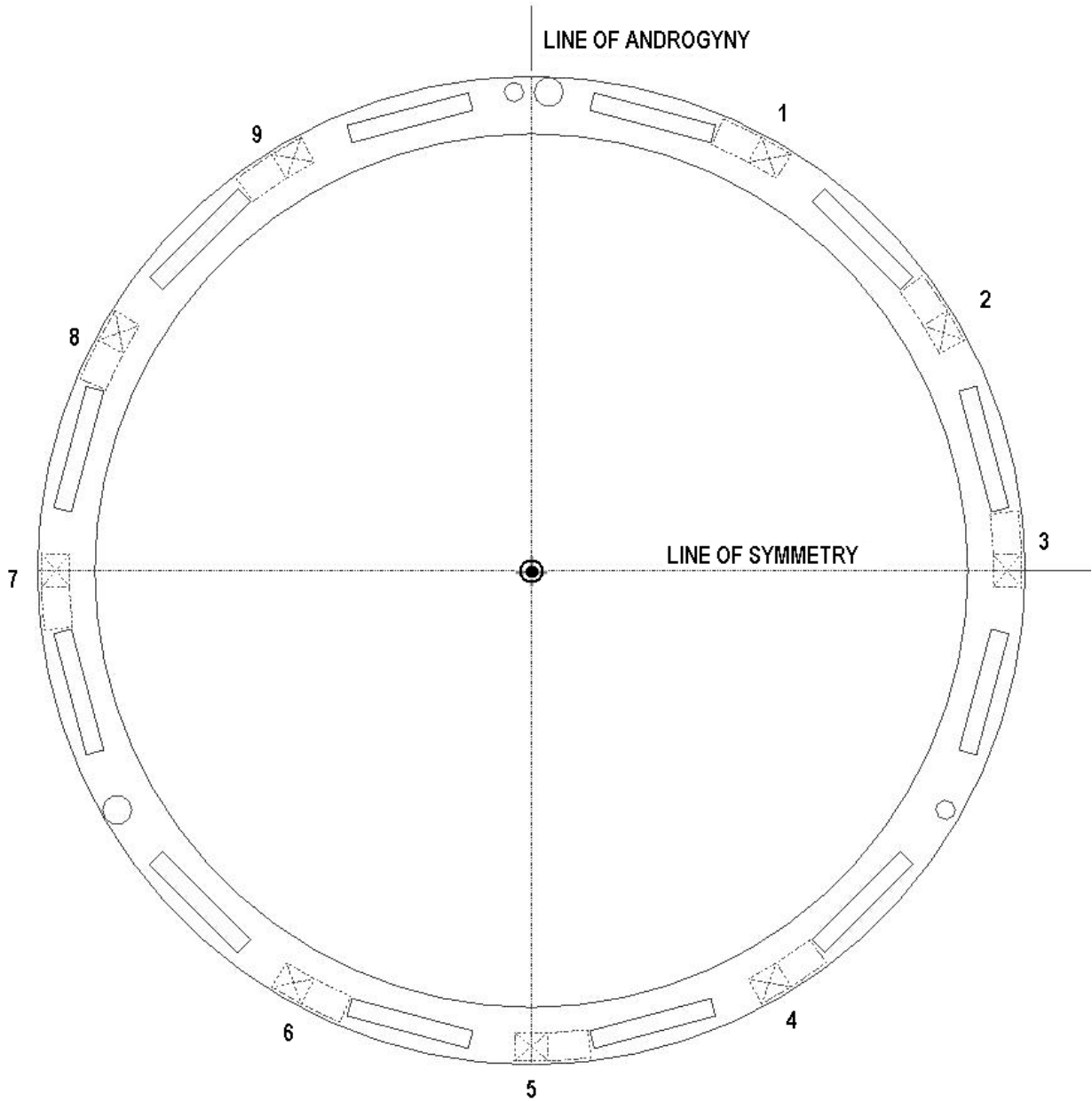
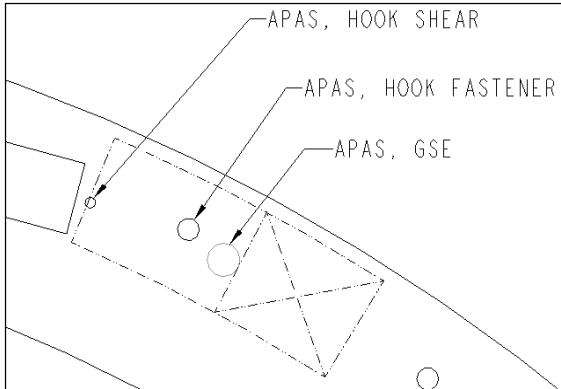
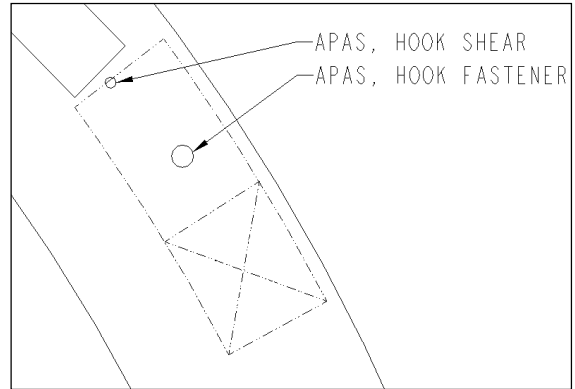

FIGURE D-1 HCS COMPONENT STRIKER ZONE REFERENCE NUMBERS



Detail applies at the following locations:
1, 3, 4, 7, 9



Detail Applies at the following locations:
2, 6

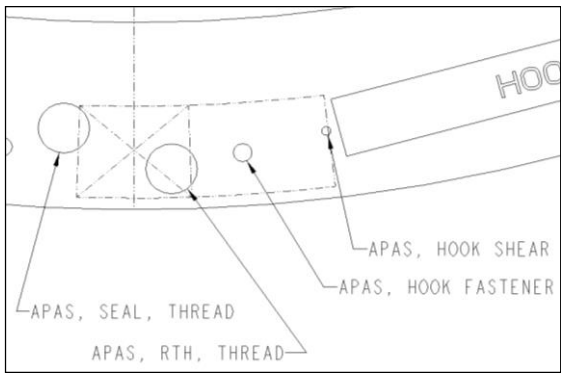

Detail applies at the following location:
5

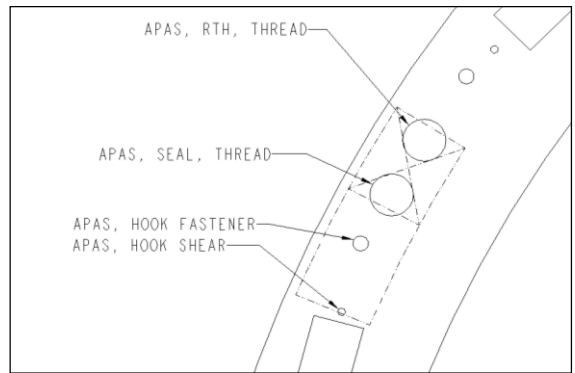

Detail Applies at the following location:
8

FIGURE D-2 APAS FEATURES WITHIN STRIKER ZONES

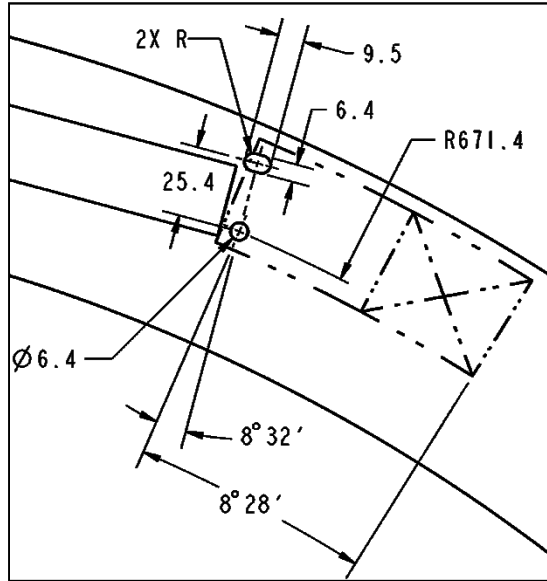

Detail applies at all locations.

FIGURE D-3 NDS FEATURES WITHIN STRIKER ZONES

APPENDIX E - MAGNETIC CAPTURE LATCH SYSTEM

In order to allow developers and participating partners to this standard the flexibility to design and build docking mechanisms to their program needs and requirements, this Appendix E describes a preliminary concept for a Magnetic Capture Latch System, geometrically compatible with the Mechanical Capture Latch System described in Section 3.2.2.4.

The Magnetic Capture Latch System is expected to offer the following features in comparison to the Mechanical Capture Latch System:

- no latch activation force is required to engage the Magnetic Capture Latch System, thereby favoring berthing,
- the activation of the Magnetic Capture Latch System is independent of the masses and approaching speeds of the mating vehicles,
- it avoids the disturbance introduced by activation load of some Mechanical Latch Capture System implementations to the sensing elements of an Actively Controlled SCS measuring the interface contact forces during the docking process,
- it allows expedited release of the Magnetic Capture Latch System, no need for re-setting of the Magnetic Capture Latch System for a new docking attempt.

Based on the above features, the Magnetic Capture Latch System is expected to be suitable for a wide range of docking/berthing vehicles as required for future Exploration missions, while reducing the number of movable parts.

Upon agreement by the interested partners, this Magnetic Capture Latch System may be implemented as an option for a specific collaborative mission, in conjunction with, or as a replacement of the Mechanical Capture Latch System.

The Magnetic Capture Latch System described in this Appendix may be realized in combination with the Mechanical Capture Latch System described in Section 3.2.2.4. Therefore a docking system implementing the strikers of both the Magnetic Capture Latch System and the Mechanical Capture Latch System can successfully mate with an active docking system implementing either the Magnetic Capture Latch System or the Mechanical Capture Latch System. The implementation of a magnetic latching system shall not impact the performance of the mechanical latching system.

For optimal soft capture magnetic force, the magnetic capture latch system shall provide each striker with surface compliance to the mating magnet. This will ensure maximum surface contact to obtain maximum magnetic force. This compliance is to account for hardware fabrication and assembling tolerances. In addition, the material selection for the striker is crucial for obtaining the required magnetic force.

In case the optional Magnetic Capture Latch System is used, Figure E-1, Cross Sectional View Through Centerline of Magnetic Latch Striker, and Figure E-2, Radial View, replace Figure 3.2.2.4-1 and Figure 3.2.2.4-2 respectively and provide the information required to develop it.

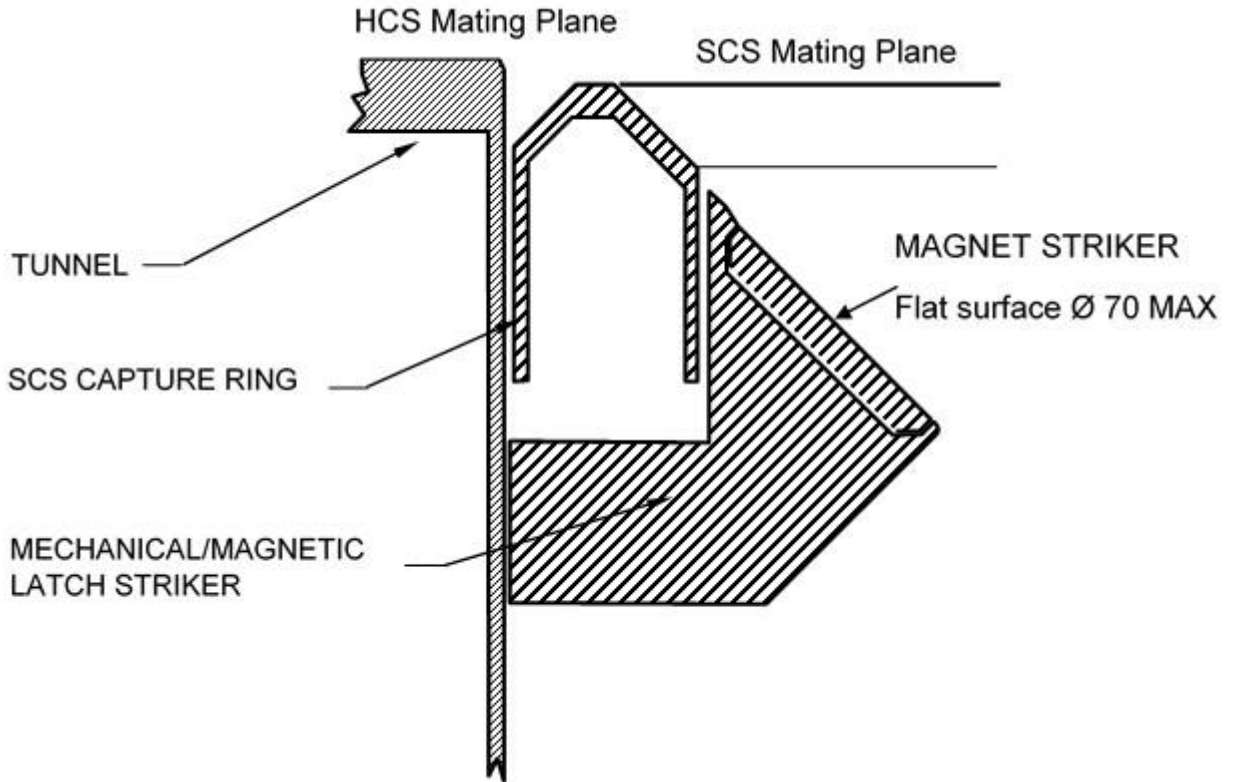

FIGURE E-1 CROSS SECTIONAL VIEW THROUGH CENTERLINE OF MAGNETIC LATCH STRIKER

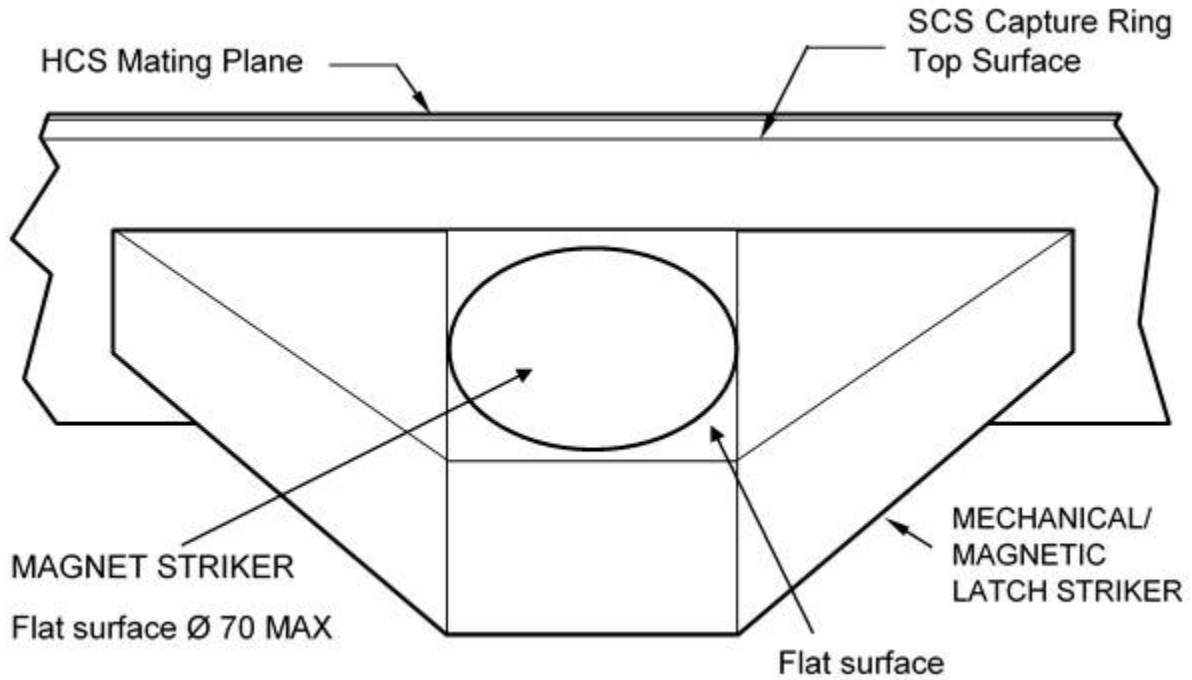













FIGURE E-2 RADIAL VIEW

Note: Dimensions on Figure E-1 and Figure E-2 are identical to those in Figure 3.2.2.4-1 and Figure 3.2.2.4-2 other than those explicitly indicated in this Appendix.

APPENDIX F – SYMBOLS DEFINITION

$\omega = [\omega_x, \omega_y, \omega_z]^T$	Angular Velocity Vector
	Basic (Theoretical) Dimension
	Between
	Centerline
	Circularity
	Concentricity
	Datum Feature
	Depth / Deep
	Diameter
	Difference
TRUE	Dimension in a view that does not show true feature shape
	Flatness
θ_y	Pitch Angle (relative to Y Axis)
	Position
ϕ_x	Roll Angle (relative to X Axis)
SR	Spherical Radius
ψ_z	Yaw Angle (relative to Z Axis)