

CHAPTER 3: ALTERNATIVES

3.1 INTRODUCTION

The effects of September 11 on Lower Manhattan and the New York City metropolitan region led to the need for revitalization of Lower Manhattan. Improvement of regional transit access to Lower Manhattan was considered essential to the successful revitalization of the area which had suffered extensive economic, transportation, infrastructure and environmental impacts. As a result, a coordinated effort was undertaken principally by the Metropolitan Transportation Authority (MTA) New York City Transit (NYCT), the Port Authority of New York & New Jersey (PANYNJ), the New York State Department of Transportation (NYSDOT) and other Federal and State agencies. The purpose of this coordination was to plan the transit improvements in Lower Manhattan that would maximize the potential benefits for the revitalization process and contribute to a full recovery of economic conditions as existed, and as would be projected to the future, pre-September 11.

To investigate potential approaches to improving its transit services and facilities, NYCT commissioned a concept study in 2002 which, upon completion, indicated that the most effective way to integrate existing transit services with potential improvements involved the construction of:

- A new prominent mass transit center on Broadway (the Entry Facility) incorporating a subsurface station concourse (the Central Station Concourse), connecting the **A C** and **4 5** service and providing better street-level access and visibility;
- A pedestrian passageway beneath Dey Street connecting the World Trade Center (WTC) site with the Entry Facility. The passageway would improve pedestrian connectivity between subway lines, particularly east-west across Lower Manhattan, and pedestrian safety, comfort, and convenience, and would provide intermodal connectivity between NYCT services and prospective Port Authority Trans-Hudson (PATH) services west of Church Street;
- Rehabilitated **2 3** and **4 5** Fulton Street Stations, improving circulation and reducing overcrowding conditions. Rehabilitation would incorporate the necessary measures to bring these stations to a state of good repair and provide operational and infrastructure improvements consistent with NYCT station planning, accessibility and design guidelines;
- Improvements to the **A C** mezzanines and platform that would facilitate way-finding, circulation and access to the street and to the platform;
- A pedestrian connector between the **R W** and **E** routes, improving west side access to Lower Manhattan and operational flexibility by permitting customers to transfer between services without payment of additional fares; and,
- Improved street access facilities to the subway, including wider and more direct stairways, access for disabled customers and new street entrances.

This combination of elements was presented as the Proposed Action, or Full Build Alternative, in the Environmental Impact Statement (EIS) Draft Scoping Document issued for public review and comment on April 3, 2003. The Draft Scoping Document also included a No Action Alternative and a request for public input into variations on Partial Build Alternatives. Additionally, as identified in the Draft Scoping Document, it is possible that the **2 3** Fulton Street Station and the **4 5** Fulton Street Station rehabilitation may occur as separate, independent projects under the NYCT Station rehabilitation program that are needed regardless of whether or not the Build Alternatives are implemented.

Since the publication of the DEIS, components of the rehabilitation of the **2 3** Fulton Street Station and the **4 5** Fulton Street Station were advanced separately. These rehabilitation activities met the requirements for a categorical exclusion under NEPA: rehabilitation or reconstruction of existing rail and bus buildings and ancillary facilities where only minor amounts of additional land are required and there is not a substantial increase in the number of users. The advancement of these independent and necessary

rehabilitation activities were anticipated in the NOI for the FSTC project. Environmental analysis of these rehabilitation activities confirmed that these activities would not individually or cumulatively involve significant social, economic or environmental impacts. For impact analysis purposes, however, these rehabilitation activities are still included in this FEIS as part of the analysis of the Proposed Action.

Pursuant to 23 C.F.R. 771.123 (c), the Final EIS (FEIS) “shall evaluate all reasonable alternatives to the action and discuss the reasons why other alternatives, which may have been considered, were eliminated from detailed study.” This Chapter concludes with the identification of the Preferred Alternative.

3.2 PUBLIC INPUT DURING PROJECT SCOPING

Following the publishing of the Draft Scoping Document, the public scoping process generated a number of additional comments relevant to the development of alternatives which suggested that the process:

- Consider variations of the Full Build Alternative (see Section 3.1) that would avoid impacts on historic resources and on the historic Corbin Building in particular. This building, located at 192 Broadway, is a National Register-listed property of considerable historical interest (see Chapter 11: Cultural Resources, for a full description of the Corbin Building);
- Consider a reduction of the property acquisition and demolition proposed within the Full Build Alternative, therefore reducing the potential socioeconomic impacts associated with the elimination of existing commercial and retail uses;
- Expand the project to enable the acquisition and development of the entire city block between Broadway, Nassau, John and Fulton Streets and provide a mix of commercial, retail and residential land uses in addition to the improved transit functions; and,
- Expand from the Full Build Alternative to include broader subway and intermodal connections. Suggestions included connecting: to a future Second Avenue Subway (SAS) station on Water Street; the PATH tracks with the **6** subway at City Hall Station; and, the **E** line tracks with the **R** **W** line tracks at Church Street.

NYCT responded to these and other comments received during the scoping period in a document entitled “Response to Comments on the Draft Scoping Document”. These responses, as well as the Draft Scoping Document, are included within this FEIS as Appendix P.

3.3 PRELIMINARY ALTERNATIVES CONSIDERED

Using information from previous planning studies, and with public outreach and agency work groups, the alternatives proposed in the Draft Scoping Document were further developed and refined during the environmental review process to generate alternatives for the Proposed Action that were responsive to public and agency comments and to the Project Goals and Purpose and Need. Particular attention was paid to avoidance and/or minimization of historic and retail impacts and property acquisition. The preliminary alternatives generated from this process are described below. These alternatives comprise seven (7) Partial Build Alternatives and three (3) Full Build Alternatives, as well as a No Action Alternative. The No Action Alternative provides for minor improvements, repairs, and other maintenance actions to the existing Fulton Street – Broadway Nassau Subway Station Complex and the **R** **W** line Cortlandt Street Station. Such maintenance would not necessarily result in stations being brought to a “State of Good Repair” as defined by NYCT Station Rehabilitation Guidelines (see Section 3.4.1). With the exception of the No Action Alternative, all alternatives include the following elements (see Table 3-1):

- A subsurface pedestrian passageway connecting the WTC site with the Fulton Street – Broadway Nassau Station Complex (Existing Complex);
- Rehabilitation of the **2** **3** and **4** **5** Fulton Street Stations;
- Improvements to the **A** **C** mezzanines and platform;
- Construction of a pedestrian connector between the **R** **W** and **E** routes; and,

**Table 3-1
Overview of Preliminary Alternatives
and Associated Improvements**

	PARTIAL BUILD ALTERNATIVES							FULL BUILD ALTERNATIVES		
	WTC Connection Only		Connection to A-C mezzanine		Central Station Concourse with Plaza Above			Central Station Concourse with Entry Facility Above		
	Fulton St.	Dey St.	Long Tunnel	Diagonal Tunnel	Removal of Corbin Building	No Integration of Corbin Building and Entry Facility	Corbin Building Integrated with Entry Facility	Removal of Corbin Building	No integration of Corbin Building and Entry Facility (Alternative 9)	Corbin Building Integrated with Entry Facility (Alternative 10)
	1	2	3	4	5	6	7	8	9	10
PROJECT ELEMENTS										
Paid-zone passageway from the WTC Complex (RW-E) to the Fulton Street Station Complex (4-5), (2-3), (A-C), (J-M-Z)	x									
ADA Elevators at Fulton and Church	x									
Connector between the northbound platform of the RW and the Fulton Street passageway	x									
Free-zone passageway from the WTC Complex (RW-E) to the Fulton Street Station Complex (4-5), (2-3), (A-C), (J-M-Z)		x	x	x	x	x	x	x	x	x
New entrance at Millenium Hotel to provide RW Street Access Stairs		x	x	x	x	x	x	x	x	x
New entrance structure at the southwest corner of Broadway and Dey Street		x	x	x	x	x	x	x	x	x
Stairs from Passageway to street (at John Street)		x	x	x						
Stairs from Passageway to north bound 4-5 platform		x	x							
Paid connector between Dey Street Passageway and lower A-C mezzanine - Running North-South Under Northbound 4-5 Platform			x							
Paid connector between Dey Street Passageway and lower A-C mezzanine - Running Diagonally from NE to SW - including a vertical circulation element midblock on east side of Broadway				x						
Below grade Central Station Concourse bounded by John, Broadway and Fulton Streets with Plaza Above Providing Vertical Access					Removal of Corbin Building	No integration of Corbin Building and Entry Facility	Corbin Building Integrated with Entry Facility			
A-C mezzanine widening between Broadway and Nassau					x	x	x	x	x	x
East-West Tunnel at 195 Broadway beneath 4-5 Tracks providing access to SB 4-5 Platform from Central Station Concourse					x	x	x	x	x	x
Below grade Central Station Concourse bounded by John, Broadway and Fulton Streets with Entry Facility Above Providing Vertical Access								Removal of Corbin Building	No integration of Corbin Building and Entry Facility	Corbin Building Integrated with Entry Facility
COMMON STREET/PLATFORM ACCESS ELEMENTS										
New entrances on the west side of Fulton and Broadway	x	x	x	x	x	x	x	x	x	x
New stairs on the southeast and southwest corner of Broadway and Cortlandt Street	x	x	x	x	x	x	x	x	x	x
Entrances on south side of John Street between Nassau and William Street	x	x	x	x	x	x	x	x	x	x
Entrances on north side of Fulton Street to the east of William Street	x	x	x	x	x	x	x	x	x	x
Entrance on west side of Nassau Street to the south of Fulton Street	x	x	x	x	x	x	x	x	x	x
New stairs connecting the east end of the A-C platform to the 2-3	x	x	x	x	x	x	x	x	x	x
COMMON STATION REHABILITATION ELEMENTS										
2-3 Fulton Street Rehabilitation	x	x	x	x	x	x	x	x	x	x
4-5 Rehabilitation	x	x	x	x	x	x	x	x	x	x
A-C Rehabilitation	x	x	x	x	x	x	x	x	x	x
COMMON ADA ELEMENTS										
J-M-Z /Nassau Street – ADA connectivity	x	x	x	x	x	x	x	x	x	x
ADA elevator on John Street for the 2-3 Fulton Street Station	x	x	x	x	x	x	x	x	x	x
ADA Access at RW-E stairs	x	x	x	x	x	x	x	x	x	x
OTHER COMMON ELEMENTS										
RW-E Connector	x	x	x	x	x	x	x		x	x

Source: MTA NYCT, Arup, The Louis Berger Group.

- Improved street access to the subway.

The Full Build Alternatives include an Entry Facility in addition to the elements above, whereas the Partial Build Alternatives do not include an Entry Facility. All alternatives, except Alternative 1, propose to locate the subsurface pedestrian passageway between the WTC and the Existing Complex beneath Dey Street; Alternative 1, locates the passageway below Fulton Street.

The main differences among the alternatives relate to:

- How the connection is implemented between the Dey Street Passageway and the **A C** platform via either a tunnel or a larger subsurface central concourse;
- How access to the subsurface central concourse is implemented, e.g. via street stairs or via an Entry Facility;
- Effects of the FSTC on the Corbin Building (i.e. demolition, avoidance or “adaptive reuse”¹); and,
- An overview of the alternatives and their characteristics is presented in Table 3-1 and Figure 3-1. The following sub-sections summarize the preliminary alternatives and present a summary of results of the engineering/environmental/economic evaluation performed, which is included in Appendix B.

3.3.1 PARTIAL BUILD ALTERNATIVES

The seven (7) Partial Build Alternatives were developed to consider excluding the Entry Facility and, to the extent possible, avoid the demolition of various structures on the Existing Complex site (see Figure 3-1). These seven (7) alternatives reflect various categories.

The first category of Partial Build Alternatives includes only a pedestrian passageway between the WTC site and the Existing Complex and consists of Alternatives 1 and 2. Alternative 1 locates the passageway beneath Fulton Street; Alternative 2 locates the passageway beneath Dey Street.

The second category of Partial Build Alternatives adds a tunnel in different configurations to Alternative 2 between the Dey Street Passageway and the **A C** platform beneath Fulton Street, one (1) block to the north. This results in Alternatives 3 and 4.

The third category of Partial Build Alternatives replaces the tunnel between the Dey Street Passageway and the **A C** platform beneath Fulton Street included in the second category with a subsurface Central Station Concourse that extends to the Dey Street Passageway. This category consists of Alternatives 5, 6 and 7. Alternative 5 requires demolition of the Corbin Building; Alternative 6 avoids the Corbin Building; and Alternative 7 proposes adaptive reuse of the Corbin Building.

A discussion of each category of Partial Build Alternatives is presented below.

CATEGORY 1: ALTERNATIVES 1 AND 2

Alternatives 1 and 2 include a passageway between the WTC site and the Existing Complex. Alternative 1 proposes such a passageway to be located under Fulton Street (see Figure 3-1). Alternative 2 proposes the passageway to be located under Dey Street.

¹ For the purposes of discussion, “adaptive reuse” is defined as making use of some or all of the Corbin Building for subway operations without unduly changing the important historic features or appearance of the building. These uses might include pedestrian entry into the FSTC via the Corbin Building, or pedestrian circulation space through lower levels of the Corbin Building. The specific details of the “adaptive reuse” proposal can be found in Chapter 11: Cultural Resources.

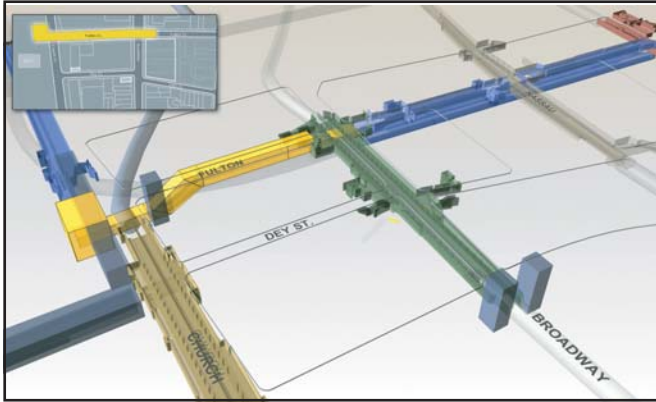

Alternative 1: Fulton Street Passageway

A new passageway between Fulton Street from Church Street to Broadway.

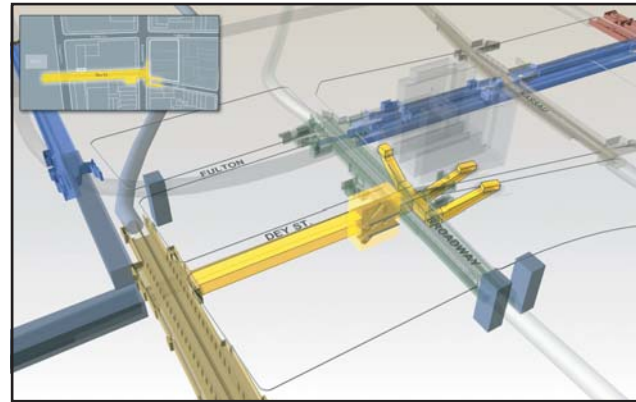

Alternative 2: Dey Street Passageway

A new passageway beneath Dey Street from Church Street to Broadway.

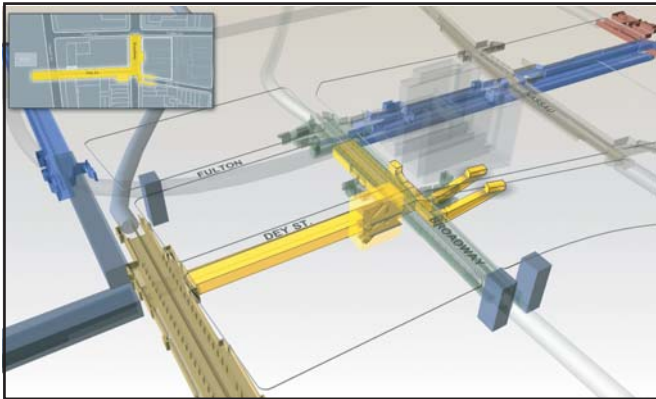

Alternative 3: Dey Street Passageway with Tunnel under 4 5 Northbound Platform

A new passageway beneath Dey Street from Church Street to Broadway with a new passageway below Broadway and beneath the 4 5 northbound platform

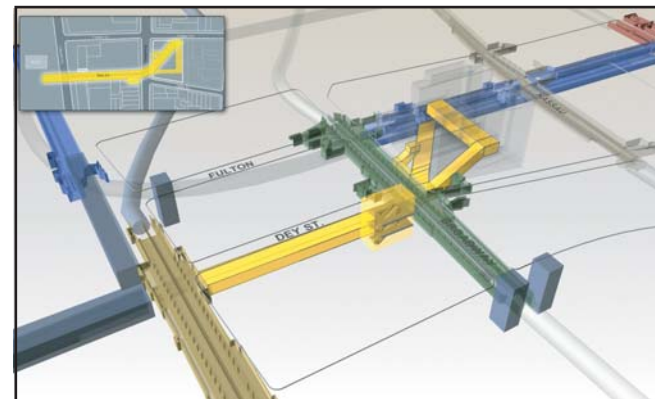

Alternative 4: Dey Street Passageway with Diagonal Tunnel Between 4 5 and A C Platform

A new passageway beneath Dey Street from Church Street to Broadway, connecting to the existing Fulton Street 4 5 pedestrian underpass and to the A C lower mezzanine.

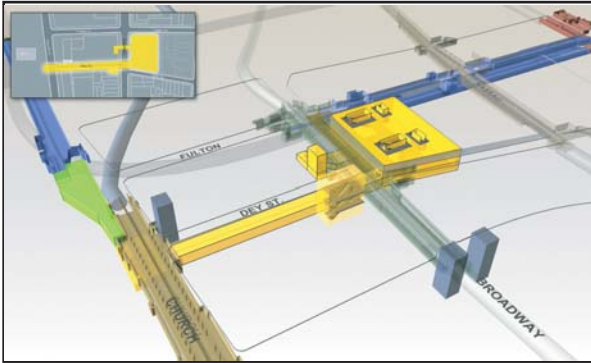

Alternative 5: Dey Street Passageway and Central Station Concourse, with Removal of Corbin Building

A new passageway beneath Dey Street with a subsurface concourse between John Street and Fulton beneath a plaza and connecting the **4 5** and **A C**.

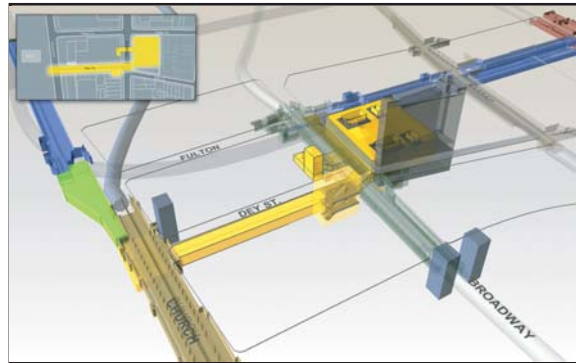

Alternative 6: Dey Street Passageway and Central Station Concourse with Retention and Avoidance of the Corbin Building

A new passageway beneath Dey Street with a subsurface concourse between John Street and Fulton beneath a plaza and connecting the **4 5** and **A C** and avoiding the Corbin Building.

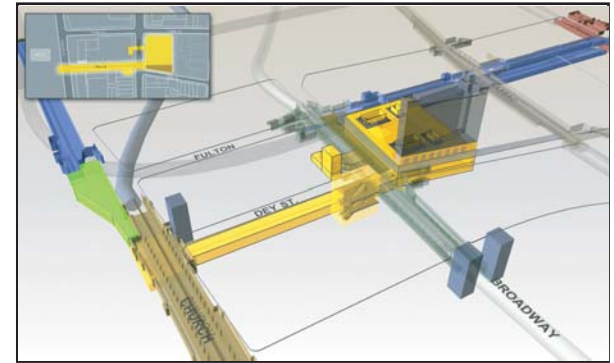

Alternative 7: Dey Street Passageway and Central Station Concourse with Adaptive Reuse of the Corbin Building

A new passageway beneath Dey Street with a subsurface concourse between John and Fulton Streets beneath a plaza and connecting the **4 5** and **A C** and adaptively reusing the Corbin Building.

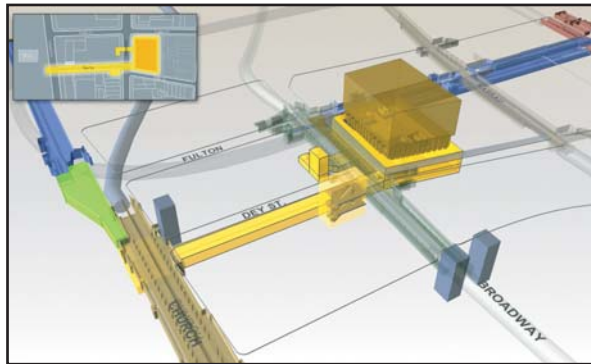

Alternative 8: Full Street Build Alternative

A passageway beneath Dey Street, with an Entry Facility between John and Fulton Streets, connecting the **4 5** and **A C** platforms. This alternative requires demolition of all buildings on Broadway, including the Corbin Building.

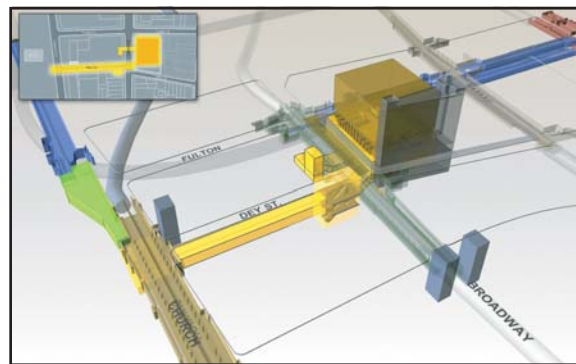

Alternative 9: Isolation of the Corbin Building

A passageway beneath Dey Street, with an Entry Facility between John and Fulton Streets, connecting the **4 5** and **A C** platforms, and avoiding the Corbin Building.

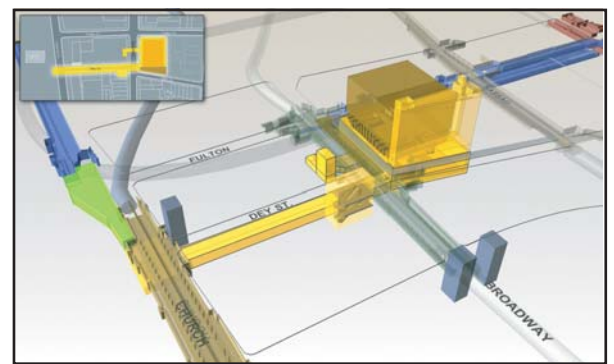

The Preferred Alternative: Adaptive Reuse of the Corbin Building

A passageway beneath Dey Street, with an Entry Facility between John and Fulton Streets, connecting the **4 5** and **A C** platforms, and incorporating adaptive reuse of the Corbin Building.

Alternative 1: Fulton Street Passageway Alternative

This alternative includes a paid-zone pedestrian passageway under Fulton Street between Broadway and Church Street, connecting to the WTC complex. The new passageway would connect the Existing Complex to the 4 5 platforms, the R W Cortlandt Street Station northbound platform and the proposed transfer between the Cortlandt Street R W southbound platform and the Chambers Street/WTC E Terminal. The passageway proceeds east under the 4 5 tracks (the existing underpass at the north end of the Fulton Street 4 5 station would be widened) to connect with the west end of the existing A C mezzanine.

A paid zone would be required. This passageway would likely be used by subway patrons and not by pedestrians seeking a subsurface route between the WTC site and destinations east of Church Street. An unpaid zone passageway under Fulton Street is not feasible as there is not adequate space at the location of the narrow 4 5 underpass to create a fare area. Space constraints therefore require the placement of fare gates at the WTC end of this passageway, requiring all users to pay a fare prior to entering.

This alternative also includes the design elements listed in Table 3-2.

Table 3-2
Project Design Elements of Alternative 1

- New entrances on the west side of Fulton Street and Broadway
- New stairs on the southeast and southwest corner of Broadway and Cortlandt Street
- A new street to mezzanine level entrance to the 2 3 Fulton Street Station at 150 William Street
- ADA elevator at 135 William Street for the 2 3 Fulton Street Station
- New stairs connecting the east end of the A C platform to the 2 3
- 2 3 Fulton Street Rehabilitation
- 4 5 Fulton Street Rehabilitation
- A C Fulton Street Rehabilitation
- R W - E Connector
- J M Z Nassau Street – Americans with Disabilities Act (ADA) connectivity*
- ADA access at R W - E stairs
- A paid-zone passageway from the WTC Complex (R W - E) to the Fulton Street Station Complex (4 5), (2 3), (A C), (J M Z)
- Elevators at Fulton and Church Streets
- Connector between the northbound platform of the R W and the Fulton Street Passageway

* **Note:** ADA connectivity would provide access to and from the street and between platforms for patrons with physical disabilities.

Alternative 2: Dey Street Passageway Alternative

This alternative, located under Dey Street, includes the same elements as the Fulton Street Passageway but replaces the passageway beneath Fulton Street with an unpaid-zone pedestrian passageway under Dey Street – the Dey Street Passageway. This passageway would be located between Broadway and Church Street, connecting to the WTC complex by widening the existing underpass at the center of the Cortlandt Street **R W** Station. This passageway provides connections to other points within the Existing Complex. The passageway would include a new entrance structure named the Dey Street Access Plaza, located at the south side of Dey Street at the intersection with Broadway. The existing property on the site of the proposed Dey Street Access Plaza, 189 Broadway, would be acquired and the building demolished to accommodate construction of the plaza. For passengers destined for northbound **4 5** service and other transit services within the Existing Complex, a connection to a reconstructed fare control area on the northbound **4 5** platform would be provided beneath John Street and customers would traverse the existing northbound platform to gain access to the **A C** station. Access to the Dey Street Passageway level would also be provided through reconfigured existing street entrances on both the north and south sides of John Street.

Alternative 2 also includes the design elements listed in Table 3-3.

Table 3-3
Project Design Elements Common Among Alternatives 2 Through 10

<ul style="list-style-type: none"> • Passageway to street stairs (John Street) • Passageway to northbound 4 5 platform stairs • New entrance at Millenium Hotel to provide R W Street Access Stairs • New entrances on the west side of Fulton Street and Broadway • <u>A new street to mezzanine level entrance to the 2 3 Fulton Street Station at 150 William Street</u> • <u>ADA elevator at 135 William Street for the 2 3 Fulton Street Station</u> • <u>New stairs on the southeast and southwest corners of Broadway and Cortlandt Street</u> • Entrances on the south side of John Street between Nassau and William Streets • Entrance on the west side of Nassau Street to the south side of Fulton Street • New stairs connecting the east end of the A C platform to the 2 3 • 2 3 Fulton Street Rehabilitation • 4 5 Fulton Street Rehabilitation • A C Fulton Street Rehabilitation • R W - E Connector • J M Z Nassau Street – ADA connectivity * • ADA access at R W - E stairs
<p>* Note: ADA connectivity would provide access to and from the street and between platforms for patrons with physical disabilities.</p>

CATEGORY 2: ALTERNATIVES 3 AND 4

Alternatives 3 and 4 expand upon Alternative 2 with a tunnel connecting the Dey Street Passageway with the **A C** platform. Alternative 3 proposes to locate this tunnel longitudinally under the **4 5** northbound platform. Alternative 4 proposes to locate this tunnel diagonally between the eastern end of the Dey Street Passageway and the **A C** mezzanine to the northeast (see Figure 3-1). A discussion of Alternatives 3 and 4 is presented below.

Alternative 3: Dey Street Passageway with North-South Tunnel under 4 5 Northbound Platform

In addition to the Dey Street Passageway and Dey Street Access Plaza, this alternative includes a pedestrian tunnel directly underneath the **4 5** northbound platform. The tunnel would connect with the existing **4 5** pedestrian underpass and would provide access from the Dey Street Passageway to the Existing Complex without requiring passengers destined for the **A C** station at Fulton Street to use the existing **4 5** northbound platform. The north-south tunnel would include a paid connection to the lower **A C** mezzanine.

This alternative also includes the common design elements listed in Table 3-3.

Alternative 4: Dey Street Passageway with Diagonal Tunnel Between 4 5 and A C platforms

In addition to the Dey Street Passageway and Dey Street Access Plaza, this alternative also includes a paid pedestrian tunnel directly underneath the **4 5** northbound platform. The tunnel would stop short of the existing **4 5** pedestrian underpass and turn northeast, arriving at the **A C** lower mezzanine level. This additional space at the junction of the **A C** and **4 5** may extend under private property at the southeast corner of Fulton Street and Broadway. Street access would be available through John Street and Broadway.

This alternative also includes the common design elements listed in Table 3-3.

CATEGORY 3: ALTERNATIVES 5, 6 AND 7

Alternatives 5, 6 and 7 are similar to Alternatives 3 and 4 but propose to use a Central Station Concourse instead of a tunnel to connect the Dey Street Passageway with the **A C** mezzanine beneath Fulton Street (see Figure 3-1). In Alternative 5, the Central Station Concourse extends for the entire length of the block along Broadway, between John and Fulton Streets, and approximately 160 feet to the east. This would involve the demolition of all structures fronting on Broadway, including the Corbin Building. Alternative 6 has a reduced footprint of the Central Station Concourse at the south, thereby avoiding the Corbin Building. Alternative 7 uses the basement of the Corbin Building and thereby proposes adaptive reuse of the Corbin Building. A discussion of Alternatives 5, 6 and 7 is presented below.

Alternative 5: Dey Street Passageway and Central Station Concourse, with Removal of Corbin Building

This alternative includes the Dey Street Passageway and the Dey Street Access Plaza. For passengers destined for northbound **4 5** service and other transit services within the Existing Complex, a connection to a reconstructed fare control area on the northbound **4 5** platform would be provided beneath John Street and customers would traverse the existing northbound platform to gain access to the **A C** station. Access to the Dey Street Passageway would also be provided through reconfigured existing street entrances on both the north and south sides of John Street. A second **4 5** underpass would be constructed connecting to vertical circulation elements via 195 Broadway and leading to the **4 5** southbound platform.

This alternative would also include a Central Station Concourse extending two (2) levels below the street on the east side of Broadway between Fulton and John Streets. As detailed in Appendix C, construction of the subsurface concourse is not feasible without removing street-level buildings and associated foundations. The resulting street-level presence would consist of an open plaza with canopied entrances along the sidewalks of Broadway, Fulton and John Streets. The Dey Street Passageway would connect the Central Station Concourse beneath the plaza with the WTC complex, facilitating horizontal and vertical circulation. The plaza and Central Station Concourse would contain public amenities, such as landscaping and seating, as appropriate.

Alternative 5 would include an entrance at 195 Broadway with a passageway underneath the 4 5 tracks and subsequent access to the plaza, and widening of the A C mezzanine between Broadway and Nassau Street.

Alternative 5 also includes the common design elements listed in Table 3-3.

Alternative 6: Dey Street Passageway and Central Station Concourse, with Retention and Avoidance of Corbin Building

This alternative, developed from Alternative 5, includes the Dey Street Passageway and the Dey Street Access Plaza. A Central Station Concourse would extend two (2) levels below the street; however the southern boundary of the Central Station Concourse would terminate at the northern wall of the Corbin Building. The Dey Street Passageway would be angled to avoid the Corbin Building, connecting the Concourse below the plaza with the WTC complex, facilitating horizontal and vertical circulation. The plaza would be an open space with canopied entrances along the sidewalks of Fulton Street and Broadway. The plaza and Central Station Concourse would contain public amenities, such as landscaping and seating, as appropriate. An entrance at 195 Broadway with a passageway underneath the 4 5 tracks would provide subsequent access to the plaza, and a second 4 5 underpass connecting to vertical circulation elements in 195 Broadway would lead to the 4 5 southbound platform. This alternative also includes widening of the A C mezzanine between Broadway and Nassau Street.

Alternative 6 also includes the common design elements listed in Table 3-3.

Alternative 7: Dey Street Passageway and Central Station Concourse, with Adaptive Reuse of Corbin Building

Alternative 7 includes the Dey Street Passageway and the Dey Street Access Plaza. The Central Station Concourse would extend two (2) levels below the street and extend underneath the Corbin Building, allowing for adaptive reuse of the building and integrating the Corbin Building basement. The Dey Street Passageway would connect the Central Station Concourse with the WTC complex, facilitating horizontal and vertical circulation. The plaza would be an open space with canopied entrances along the sidewalks of Fulton Street and Broadway. The plaza and Central Station Concourse would contain public amenities, such as landscaping and seating, as appropriate. An entrance at 195 Broadway with a passageway underneath the 4 5 tracks would provide subsequent access to the Central Station Concourse, and a second 4 5 underpass connecting to vertical circulation element in 195 Broadway would lead to the 4 5 southbound platform. This alternative also includes widening of the A C mezzanine between Broadway and Nassau Street.

Alternative 7 also includes the common design elements listed in Table 3-3.

3.3.2 FULL BUILD ALTERNATIVES

Full Build Alternatives include the Dey Street Passageway, the Dey Street Access Plaza and a street-level Entry Facility; they vary the Entry Facility in terms of the size of the footprint and the treatment of the

Corbin Building. The three (3) Full Build Alternatives are variations on Alternatives 5, 6 and 7 and are as follows:

Alternative 8

Defined in the Scoping Document as the Full Build Alternative, this alternative extends for the entire block along Broadway between John and Fulton Streets, from Broadway to 160 feet to the east. It maximizes street frontage on Broadway and includes the Entry Facility of the largest extent by requiring demolition of all buildings on Broadway between John and Fulton Streets, including the Corbin Building. In this alternative, the Dey Street Passageway connects in a straight line into a Central Station Concourse below the Entry Facility. A subway entrance within the Broadway lobby of 195 Broadway with a passageway underneath the 4 5 tracks would provide subsequent access to the Central Station Concourse, and a second 4 5 underpass connecting at lower levels within 195 Broadway would lead to the 4 5 southbound platform.

This alternative also includes a subsurface Central Station Concourse bounded by buildings on John and Fulton Streets comprising of 194-196, 198, 200-2002 and 204-210 Broadway with vertical access to the Entry Facility above, and widening of the A C mezzanine between Broadway and Nassau Street.

Alternative 8 also includes the design elements listed in Table 3-3.

Alternative 9

This alternative modifies Alternative 8 by reducing the size of the Entry Facility so as not to engage or acquire the Corbin Building (see Figure 3-1). The southern extent of the Entry Facility would be the northern wall of the Corbin Building. This results in an angled connection between the Dey Street Passageway and the Central Station Concourse beneath the Entry Facility. A subway entrance within the Broadway lobby of 195 Broadway with a passageway underneath the 4 5 tracks would provide subsequent access to the Central Station Concourse, and a second 4 5 underpass connecting at lower levels within 195 Broadway would lead to the 4 5 southbound platform. This alternative also includes widening of the A C mezzanine between Broadway and Nassau Street.

Alternative 9 also includes the design elements listed in Table 3-3.

Alternative 10

This alternative integrates the basement and ground floor of the Corbin Building into the Entry Facility (see Figure 3-1). This creates an effective footprint of the Entry Facility almost as large as that in Alternative 8, but it does not require demolition of the Corbin Building. In this alternative, the Dey Street Passageway connects in a straight line into the basement of the Corbin Building; the ground level of the Corbin Building functions as a street-level entryway into the Entry Facility from John Street. A subway entrance within the Broadway lobby of 195 Broadway with a passageway underneath the 4 5 tracks would provide subsequent access to the Central Station Concourse, and a second 4 5 underpass connecting at lower levels within 195 Broadway would lead to the 4 5 southbound platform. This alternative also includes widening of the A C mezzanine between Broadway and Nassau Street.

Alternative 10 also includes the common design elements listed in Table 3-3.

3.3.3 EVALUATION OF PRELIMINARY ALTERNATIVES

The ten (10) preliminary alternatives were evaluated with respect to the seven (7) project goals and constructability, cost effectiveness and environmental considerations; special regard was given to historic and socioeconomic resources. A detailed description of the evaluation process is provided in Appendix B. The results of the evaluation are summarized below and in Table 3-4.

Partial Build Alternatives

Alternatives 1 and 2 incurred unacceptable pedestrian Level of Service (LOS) problems and were eliminated from further consideration.

Alternatives 3 and 4 incurred substantial construction challenges related to underpinning various structures (e.g. the ④⑤ line, existing buildings). Although Alternatives 3 and 4 had the lowest concept level investment cost (the group average is hereinafter referred to as the Base Cost), and had the lowest impact on retail and historic resources, they were also excluded from further consideration as they did not achieve the full range of project goals.

Alternative 5 was eliminated from further consideration because of its impacts on the Corbin Building as a historic resource. According to the regulations at 23 C.F.R. 771.135 that have been promulgated under Section 4(f) of the U.S. Department of Transportation Act of 1966 (49 U.S.C. 303), this alternative could only be approved if there were no feasible and prudent alternative. As such alternatives do exist (in the form of Alternatives 6, 7, 9 and 10), Alternative 5 was eliminated from further consideration.

Alternatives 6 and 7, while performing better in terms of addressing some of the project goals, would not provide adequate wayfinding at street-level and also have considerable engineering and cost constraints. The concept level investment costs for Alternatives 6 and 7 are approximately 15 percent greater than the Base Cost (associated with Alternatives 3 and 4). Alternatives 6 and 7 would also eliminate retail activity at street-level without replacing it as part of a new Entry Facility. Impacts on historic resources vary for Alternative 6 and 7. Alternative 6 avoids the Corbin Building while Alternative 7 integrates the Corbin Building at street-level and subsurface.

The evaluation of the seven (7) Partial Build Alternatives confirmed that certain characteristics or elements proposed in the Build Alternatives, but absent in the Partial Build Alternatives, were critical to achieving the project Purpose and Need; specifically:

- The street-level and subsurface Entry Facility, proposed as part of the Full Build Alternatives, is a critical project element in the achievement of the project goals. The Entry Facility is essential to supporting the multiple project goals of facilitating access, improving wayfinding, improving travelers' experience and transit's overall attractiveness, and supporting the recovery and rebuilding of Lower Manhattan. Any Build Alternatives without an Entry Facility do not satisfy the project Purpose and Need and multiple project goals; and,
- The most appropriate location for the subsurface passageway is Dey Street, continuing from Church Street under Broadway to connect with the Entry Facility.

Full Build Alternatives

Alternative 8 would require the demolition of the Corbin Building, a structure listed on the National Register of Historic Places. Because feasible and prudent alternatives pursuant to the Section 4(f) regulations at 23 C.F.R. 771.135 exist, this alternative was not advanced for further consideration.

Although the remaining Full Build Alternatives are more costly than the Partial Build Alternatives 6 and 7 (their cost is 20 percent (Alternative 9) to 33 percent (Alternative 10) higher than the Base Cost), they make a greater contribution to the achievement of the project goals. Although either remaining Full Build Alternative 9 or 10 would require the deconstruction of several structures containing Broadway retail frontage, the Entry Facility could replace such lost retail with some new retail, thereby reducing any permanent impacts.

Results of Preliminary Alternatives Evaluation

The two (2) Full Build Alternatives, Alternative 9 and Alternative 10, are the only alternatives evaluated which fully address the project goals and the project Purpose and Need while also avoiding or minimizing

impacts to the Corbin Building. Among all preliminary alternatives considered, they are judged as the only reasonable alternatives to be considered for detailed analysis in this FEIS. Based on conceptual level engineering analysis, both alternatives are considered technically feasible and cost effective. These alternatives were, therefore, selected for further analysis regarding their potential environmental impacts and are carried forward for analysis. After the DEIS's completion, NYCT has continued to refine Alternatives 9 and 10, based on continuing engineering investigations, coordination and public comments made on the DEIS. NYCT has identified a Preferred Alternative, as described in Section 3.6.

3.4 DESCRIPTION OF ALTERNATIVES FOR DETAILED ANALYSIS

3.4.1 NO ACTION ALTERNATIVE

The No Action Alternative is included for detailed analysis pursuant to 40 C.F.R. 1502.14(d) of the Council on Environmental Quality regulations and assumes that the Existing Complex would remain as is, except for routine maintenance repairs that would not be subject to environmental review. Such maintenance would not necessarily result in stations being brought to a "State of Good Repair" as defined by NYCT Station Rehabilitation Guidelines. Under this alternative, none of the project elements described in Chapter 1: Purpose and Need would be undertaken.

The No Action Alternative also includes other Lower Manhattan Recovery Projects proposed for construction in Lower Manhattan between 2004 and 2025. These include the following:

- The WTC Redevelopment (construction expected late 2004 to end 2014);
- The Permanent WTC PATH Terminal (construction expected early 2005 to end 2008);
- The West Street/Route 9A Reconstruction (construction expected mid 2004 to end 2008); and,
- The Reconstruction of the South Ferry Subway Terminal (construction expected mid 2004 to end 2006).

Both construction and operational aspects of these projects are taken into account for the 2005/2006 and 2008 analysis years of the FSTC. By 2025, all these projects are expected to have been completed for several years. Also taken into account in the analysis are roadway reconstruction activities planned by NYCDOT in Lower Manhattan to the extent that these activities would affect vehicular and pedestrian access and circulation. Other projects proposed for completion in Lower Manhattan during 2005/2006-2025 are presented in Chapter 7: Social and Economic Conditions.

3.4.2 ALTERNATIVE 9

Alternative 9 consists of the construction and operation of a rehabilitated, reconfigured and enhanced multi-level, subsurface station complex in Lower Manhattan that would serve 12 NYCT subway lines (see Figure 3-2). The proposed FSTC, an integrated complex of four (4) subway stations and associated connecting corridors, includes improved platforms, mezzanines and connection corridors, and a new Central Station Concourse, with surface presence distinguished by a street-level Entry Facility on Broadway. In contrast to Alternative 10 (see Section 3.4.3), the Entry Facility for this alternative does not link with the Corbin Building and makes no operational use of that building.

The FSTC would extend subsurface from the Existing Complex westward one (1) block to Church Street through a new pedestrian passageway below Dey Street. This passageway would connect to the future concourse at the WTC site, from which access to a variety of transit options similar to those existing pre-September 11 is anticipated to be available.

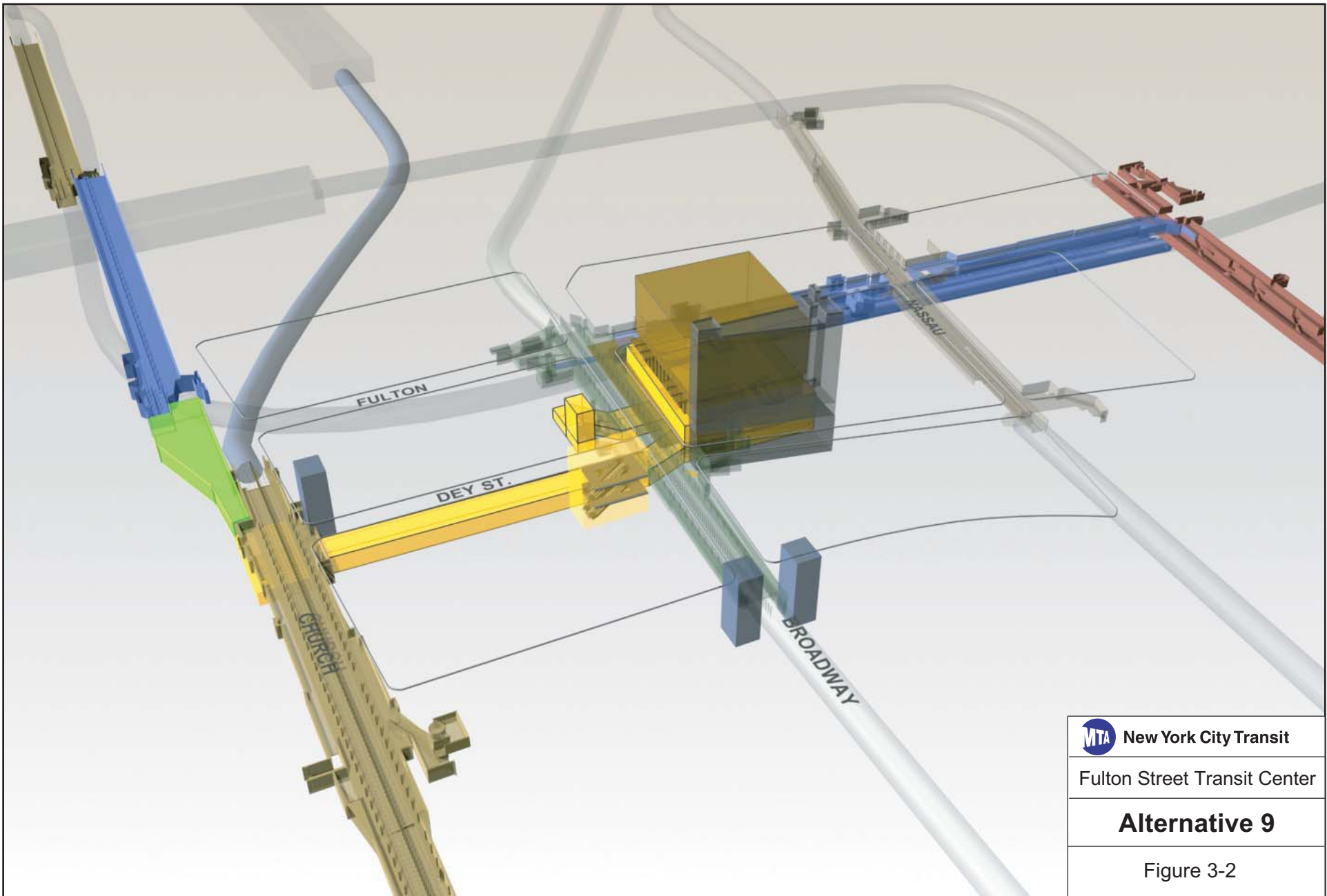

 New York City Transit
Fulton Street Transit Center
Alternative 9
Figure 3-2

**Table 3-4
Summary of Alternatives Evaluation
Alternatives Matrix**

ALTERNATIVES		BUILD EXTENT	MEETING PROJECT GOALS							Feasibility / Cost Effectiveness		Environmental (Historic/Socioeconomic) Considerations		
			1	2	3	4	5	6	7	Feasibility	Cost Effectiveness	Construction	Operational	
WTC CONNECTION ONLY														
1	Fulton Street Passageway	PARTIAL	-	0	-	0	-	-	-	-	0	0	0	0
2	Dey Street Passageway	PARTIAL	-	0	-	0	-	-	-	+	0	+	0	0
CONNECTION TO A C MEZZANINE														
3	Det Street Passageway with Longitudnal Tunnel Under 4 5	PARTIAL	0	0	0	0	0	0	-	0	0	0	0	0
4	Dey Street Passageway with Diagonal Tunnel to A C	PARTIAL	-	0	0	0	0	0	0	0	0	0	0	0
CENTRAL STATION CONCOURSE WITH PLAZA ABOVE														
5	Dey Street Passageway with Central Station Concourse and Plaza (Removal of Corbin Building)	PARTIAL	+	+	+	+	+	0	+	+	+	-	-	-
6	Dey Street Passageway with Central Station Concourse and Plaza (No Integration of Corbin Building)	PARTIAL	+	+	+	+	+	0	+	+	+	0	0	0
7	Dey Street Passageway with Central Station Concourse and Plaza (Corbin Building Integrated with Entry Facility)	PARTIAL	+	+	+	+	+	0	+	+	+	0	0	0
CENTRAL STATION CONCOURSE WITH ENTRY FACILITY ABOVE														
8	Dey Street Passageway with Central Station Concourse and Entry Facility (Removal of Corbin Building)	FULL	+	+	+	+	+	+	+	+	+	-	-	-
9	Dey Street Passageway with Central Station Concourse and Entry Facility (No Integration of Corbin Building)	FULL	+	+	+	+	+	+	+	+	+	0	+	+
10	Dey Street Passageway with Central Station Concourse and Entry Facility (Corbin Building Integrated with Entry Facility)	FULL	+	+	+	+	+	+	+	+	+	0	+	+

Legend:

- + Supports the goal/criterion
- 0 Limited or Marginal achievement of goal/criterion
- Detracts from the goal/criterion

Project Goals:

- 1 Facilitate Access, Improve Wayfinding, Streamline Transfers.
- 2 Allow for Intermodal Connectivity.
- 3 Promote System Flexibility in the event of service disruption.
- 4 Improve East-West Pedestrian Connectivity across Lower Manhattan.
- 5 Promote Safety and Reduce Congestion at heavily Trafficked street crossings.
- 6 Support Current Lower Manhattan Recovery/Rebuilding.
- 7 Improve Travelers' Experience and Overall Attractiveness.

The FSTC, by virtue of its many subway connections to commuter hubs such as Grand Central Terminal, Pennsylvania Station, the Permanent WTC PATH Terminal and Atlantic Terminal, would also form a key access point for workers coming to Lower Manhattan from Long Island, Westchester County and New Jersey using commuter rail. The elements constituting Alternative 9 are described in detail below (see Figure 3-3).

These guidelines include detailed specifications for the renovation, repair and/or replacement, as appropriate, of station elements, including stairs, railings, platforms, ceilings, walls, floors, lighting, signage, control areas, public address systems, bathrooms and service facilities. The No Action Alternative would not necessarily include all such renovations and repairs.

ENTRY FACILITY

A new prominent Entry Facility at the street and subsurface levels would be centrally located on Broadway between Fulton and John Streets. It would integrate horizontal connectivity between the **A C** and **4 5** service with vertical connectivity between the street and different levels and provide improved street-level access and visibility. It would be functionally and operationally isolated from the Corbin Building, resulting in effects on several aspects of the overall design.

At street-level, the Entry Facility would be located on the east side of Broadway between Fulton Street and the Corbin Building, extending approximately 160 feet eastward into the block. Relative to the subway, the Entry Facility would be located at the intersection of the **4 5** and **A C** lines and in close proximity to the **J M Z** station.

The Entry Facility would enhance overall connectivity and provide a prominent new civic structure as the principal entrance to the subway system and to subsurface public spaces. It would incorporate a street-level structure and subsurface Central Station Concourse. The Entry Facility would serve as a highly visible focal point of subway transit in Lower Manhattan, replacing multiple entrances with prominent entrances on Broadway and additional entrances on Fulton Street. It would provide a major connection node for the subway system, offering maximum utility for both passengers and pedestrians.

The Entry Facility would be designed to provide a large open space that would use natural light and direct views wherever possible to enhance wayfinding with minimal reliance on signage. To improve wayfinding, the interior design would be consistent in character throughout the facility, establishing a unified visual environment throughout all elements of the FSTC. Existing transfers between the **4 5** and **A C** lines would be greatly improved, with new escalators and stairways providing convenient access and reducing congestion, and providing a consistent standard of service in accordance with demand. Access to the **4 5** southbound platform is augmented by a proposed new street entrance structure at Broadway and Dey Street, known as the Dey Street Access Plaza.

Vertical transition within the Entry Facility would be efficiently achieved using escalators and new stairways, which would be sized according to projected passenger volume and could be directed in response to anticipated flow. This provides a consistent level of service for all users. Elevators would be provided to make the **4 5**, **A C** and **J M Z** platforms accessible to disabled passengers, and elevators connecting unpaid levels would be provided for Americans with Disability Act (ADA) access and passenger convenience.

From the street-level down, the Entry Facility would be vertically organized on four (4) levels (see Figure 3-4):

Street Entry Level: This level would include entrances from the street into an enclosed major public space that would provide open and direct access to lower levels and would be designed to aid visibility and wayfinding among subway lines. Main entrances along Broadway and Fulton Street would open into the Entry Facility with clear sightlines into the Central Station Concourse below. Limited retail and ancillary activities may be provided at this level.

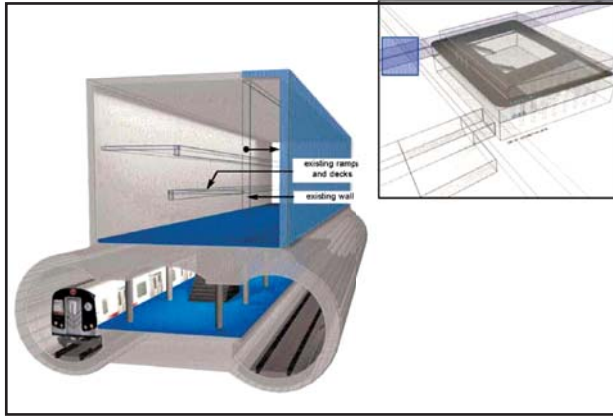

Clear out existing **A** **C** mezzanine and widen.

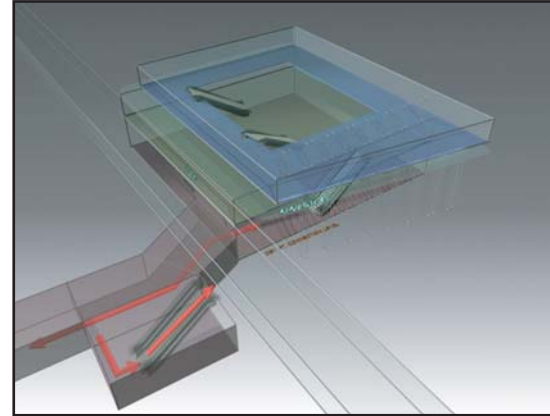

Shift Dey Street Passageway north to avoid Corbin Building.

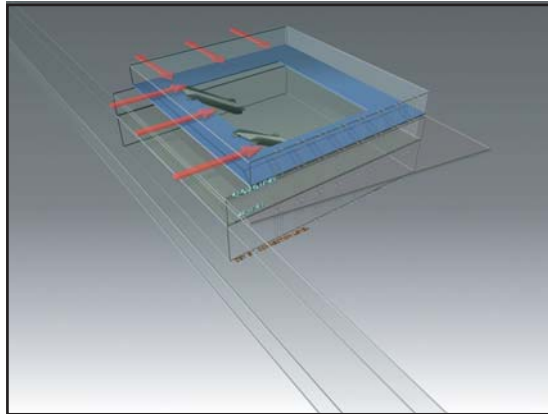

Street access from Broadway only - no John Street access.

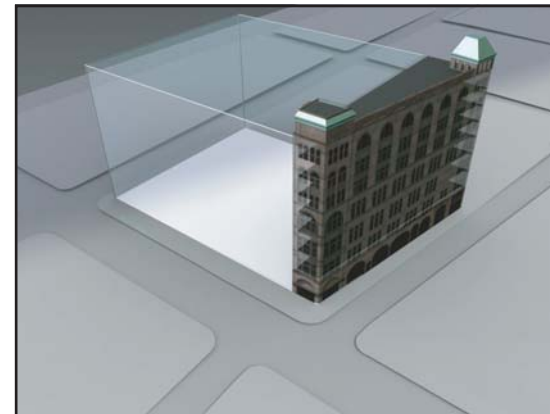

Leave Corbin Building intact throughout.

Legend

- Unpaid Circulation
- Paid Circulation
- Support Facilities
- NYCT Operations
- Retail



Street-Level Plan

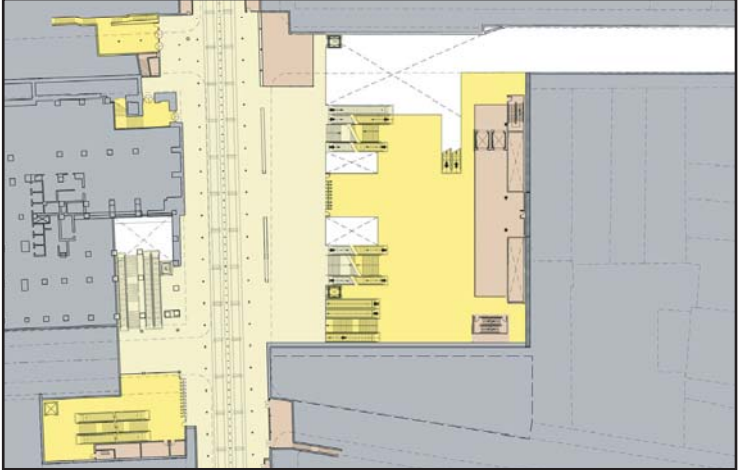

4 5 Platform Level Plan

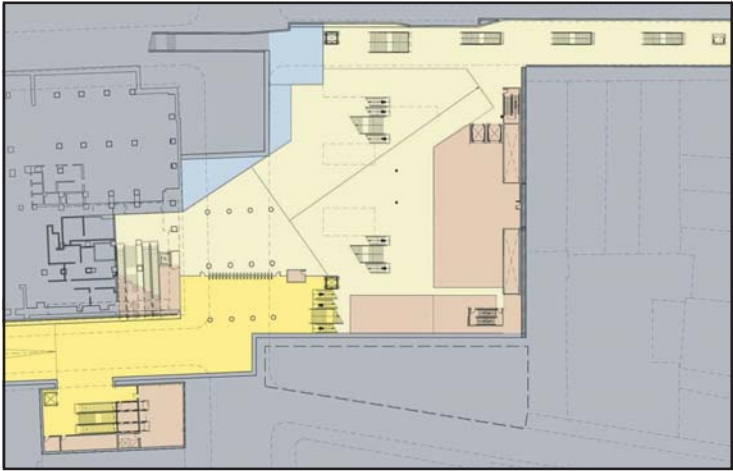

Concourse Level Plan

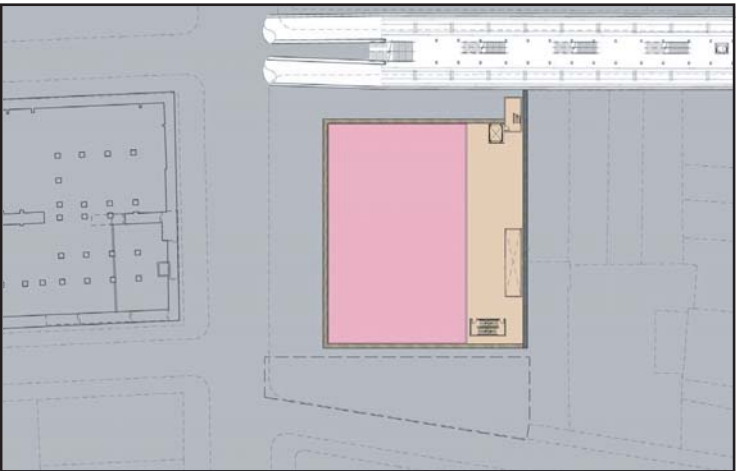

A C Platform Level Plan

New York City Transit
Fulton Street Transit Center
Alternative 9
Entry Facility Floor Plans
-Street Level and Below
Figure 3-4

One (1) level below street-level - Entry Facility Central Station Concourse and 4 5 Platform Level: This level would be linked to the street-level via elevator, escalators and stairs, and would provide direct access into the 4 5 northbound platform at the same level, and to the new Central Station Concourse one (1) level below. Similar to street-level, retail and ancillary activities would be limited on this level. This level would provide an ideal location for transit-wide information services and a visitors' center, as it would be visible to both transferring passengers and those entering and exiting the system.

Two (2) levels below street-level – Dey Street Passageway and A C mezzanine level: This level would include the A C mezzanine, a new link from the 4 5 southbound platform and access to the proposed Dey Street Passageway. This would also result in access improvements to the J M Z and 2 3 lines. To accommodate necessary structural clearances, this level would incorporate a level change of approximately six (6) feet between the A C mezzanine and Dey Street Passageway. To limit potential disruptions, this transition level would be positioned away from the A C mezzanine edge, so that passengers transferring to the northbound 4 5 still have easy access to both the north and south ends of the uptown platform.

Access to the Entry Facility would not be possible via the Corbin Building (see Figure 3-5), and pedestrians using the Dey Street Passageway would encounter a blank wall as they reach the end of the Passageway before turning northeast to access the Central Station Concourse. Access to the street from the eastern end of the passageway would require a circuitous route up through the Central Station Concourse and out onto Broadway, or alternatively pedestrians could exit at the Dey Street Access Plaza (see Figure 3-4: Concourse Level floor Plan). Both these options could potentially reduce the pedestrian LOS at entry and exit points into the FSTC.

Three (3) levels below street-level – Equipment Room Level: The partial level would include the basement of the Entry Facility, which would house support facilities and equipment. Although not accessible at this level, the A C platform would be at the same elevation.

From street-level up, the Entry Facility would be organized on as many as five (5) levels, depending on the final design. These would be open mezzanines surrounding the Central Concourse and designed to allow views among all levels within the Entry Facility and Central Station Concourse, and maintaining natural light from the highest level down through the Entry Facility. All levels would be served by internal escalators and/or stairways. The levels would be organized as follows:

One (1) level above street-level – Mezzanine Level: This level would be approximately 20 feet above street-level, to ensure open views between the Entry Facility and the surrounding streets. This level would be used for public amenity and could include both exhibition and retail space.

Two (2) levels above street-level – Upper Mezzanine Level: This level would be used for public amenity and could include both exhibition and retail space.

Three (3) levels above street-level –Mechanical Equipment Level: This level would be designated as a service floor. By positioning equipment in self-contained boxes within the perimeter, mechanical equipment could be acoustically isolated and could be maintained with limited disruption to activities in the Entry Facility interior open space. The placement of mechanical equipment at this level would also allow the rooftop to be made available for publicly accessible activities. It is intended that the equipment would be housed behind the building's layered façade, maintaining the appearance of a continuous streetwall from the surrounding streets.

It is anticipated that the FSTC Entry Facility would be structurally isolated from the Corbin Building at street-level and also subsurface. There would be no structural alterations to the Corbin Building or access between the Corbin Building and the Entry Facility. A subsurface containment wall constructed of either bored piles or a slurry wall would separate the Entry Facility from the Corbin Building.



Figure 3-5: Corbin Building seen from John Street under Alternative 9



Figure 3-6: Dey Street Passageway Connection to Entry Facility Under Alternative 9.

 New York City Transit
Fulton Street Transit Center
Alternative 9 Design Concepts
Figure 3-5 & Figure 3-6

This wall would form a permanent retaining wall for the Corbin Building. In addition, underpinning of the Corbin Building is likely required to ensure stability of the building.

DEY STREET PEDESTRIAN PASSAGEWAY

A new pedestrian passageway is proposed under Dey Street between Broadway and Church Street connecting the Entry Facility to the WTC site. Starting at the Entry Facility two (2) levels below street-level, this unpaid passageway would extend southwest initially to avoid the Corbin Building, crossing under the 4 5 line; it would then continue west under Dey Street to Church Street at the R W line Cortlandt Street Station. The proposed Dey Street Passageway would connect to the WTC site by way of the existing R W underpass, which would be widened. The passageway would include stairway and ADA elevator connections to the northbound and southbound R W platforms. At its western end, the passageway would be fully integrated with the redevelopment of the WTC site; detailed design would be coordinated with WTC plans as these are developed.

As this alternative does not include a direct connection from the Entry Facility to John Street (see Figure 3-6), an additional street stair may be required to connect the Dey Street Passageway to John Street. Alternatively, an existing easement in the Corbin Building could potentially be used to accommodate such access.

The Dey Street Passageway would include a new entrance structure at the southwest corner of Broadway at Dey Street - the Dey Street Access Plaza. It would serve as an entrance to the 4 5 southbound platform and the Dey Street Passageway. The existing property, 189 Broadway, would be acquired and the two (2)-story building demolished to accommodate construction of the Dey Street Access Plaza. The Dey Street Access Plaza is proposed as an open plaza formed by the placement of a rear vertical glass surface on the south boundary and a horizontal glass canopy overhead. The vertical surface will direct natural and artificial reflective light to the lower levels. The horizontal glass canopy would be hung from the vertical wall with a cable suspension system providing shelter and natural illumination over the stairway and escalators which access the Dey Street Passageway and FSTC Entry Facility. The design of the Plaza will be enhanced by glass benches and bollards providing an area of public seating on Broadway (please see Figures 3-7 and 3-8). The new structure would be comprised of a protective canopy over the street entrances and two (2) levels of vertical circulation elements subsurface. It would also house ADA access and mechanical equipment.

Additional street entrances to the Dey Street Passageway would be provided on the north side of Dey Street at the Millennium Hotel on Church Street. All four (4) of the existing entrances to the subway system at the intersection of Church and Dey Streets would be renovated or reconstructed.

The Dey Street Passageway is currently proposed to be an unpaid connection between the WTC site and the FSTC and, as such, is expected to serve a larger volume of people than if it were strictly a paid-zone to paid-zone transfer between the FSTC and the E and R W subway lines. The Dey Street Passageway would allow pedestrians to avoid crossing Church Street and Broadway, both of which are busy vehicular arterials.

STATION REHABILITATION

Alternative 9 includes the rehabilitation of the 4 5 line Fulton Street Station and the 2 3 line Fulton Street Station. These improvements would include station repairs and upgrading, as well as new elevators to make the platforms accessible to disabled passengers. New street access is proposed for the 4 5 line on both northbound and southbound platforms at the southern ends. Several improvements are proposed to address ADA requirements, including a new elevator at the northern end of the southbound 4 5 platform and an additional new elevator between the A C platform, lower mezzanine and upper mezzanine levels. These improvements would make the 4 5 line, the A C line Broadway - Nassau Station and the transfers between them ADA accessible. The existing 4 5 platforms of the Fulton Street Station may be reconfigured and opened to the mezzanine level of the new Entry Facility.



 **New York City Transit**
Fulton Street Transit Center
Dey Street Access Plaza
View from Street Level
Figure 3-7



 New York City Transit
Fulton Street Transit Center
Dey Street Access Plaza Connecting to Dey Street Passageway
Figure 3-8

In considering these improvements, as well as those envisioned for functional upgrading and integration with the Entry Facility, the historical character of the stations would be taken into consideration and efforts to preserve or reuse historical elements would be included in the design.

4 5 Line Fulton Street Station Rehabilitation

This station was constructed as part of the Rapid Transit Subway Construction Company's project for the first subway system in New York and was opened on January 16, 1905. Because of its historical significance, the station's original platform containing mosaic wall tiles, marble and terra cotta retain historic landmark status. This station would be rehabilitated with the goal of preserving as much of this historic fabric as possible, while at the same time modernizing the station to meet the current and future needs of NYCT and its passengers.

Existing passenger congestion would be remedied through the integration of the 4 5 and A C Fulton Street Station with the Entry Facility. Through the Entry Facility, improved connections would be provided to both the northbound and southbound platforms. For example, by increasing the easement into 195 Broadway, a new 4 5 underpass has been proposed via a bank of escalators, stairs and an elevator. This would improve the LOS for transferring customers, and would replace the current connection between the southbound 4 5 and the A C mezzanine. In addition, all existing control areas on the northbound side of the station would be eliminated due to their incorporation into the Entry Facility. This would permit parts of the east wall of the 4 5 platform to be selectively removed, opening up the majority of the northbound platform to the Entry Facility, while accounting for historical features of the station.

A proposed control area at Dey Street and Broadway would allow a larger passenger volume to enter and exit the 4 5 Fulton Street Station and the Dey Street Passageway via another bank of escalators, stairs and an elevator. At the south end of the station, the platforms would be widened, and new street-level stairs would be installed. This would not only provide for a more inviting and safer space than currently exists, but it would also help to relieve some passenger congestion at the platform during the construction phase.

The rehabilitation of the 2 3 Fulton Street Station would ensure that the station is brought to a state of good repair (in accordance with the NYCT Station Planning and Design Guidelines discussed above). This would include replacement of the existing floor finish with new tiles, replacement or restoration of the existing mosaic tile bands that are faded or damaged and repainting of all exposed steel and concrete within the station. Existing structural and water infiltration deficiencies would be identified and remedied.

2 3 Line Fulton Street Station Rehabilitation

The existing station opened in 1918 and is in need of rehabilitation. This station is accessed via two (2) sidewalk street stairs on Fulton Street and three (3) private property stairs, two (2) at 110 William Street (one (1) of which is accessed via the John Street side of the building), and one (1) at 130 William Street. The smaller mezzanine, which is to the north of Fulton Street, is an "exit only" mezzanine that requires passengers to traverse a long corridor through a City-owned building before reaching the stairs up to the street. This north mezzanine is in poor condition and does not have adequate signage or wayfinding devices.

As part of the rehabilitation, a connecting passageway and stairs would be constructed between the platform level of the A C line and the platform level of the 2 3 line, providing a direct transfer connection and an additional means of egress from the A C platform. This connection would relieve some of the congestion that would occur as a result of the construction work at the mezzanine levels above. Alternatively, an elevator could be constructed here to provide a direct connection from the 2 3 platform to the A C platform. A new elevator would be constructed from street to mezzanine level using

an existing easement within 135 William Street. A new entrance from street level to the 23 Fulton Street Station would also be constructed within 150 William Street.

The rehabilitation of the 23 Fulton Street Station would ensure that the station is brought to a state of good repair (in accordance with the NYCT Station Planning and Design Guidelines discussed above). This would include replacement of the existing floor finish with new tiles, replacement or restoration of the existing mosaic tile bands that are faded or damaged and repainting of all exposed steel and concrete within the station.

ADA compliance at the station would be achieved through appropriate installation of elevators and modification of all stairs. This would include new handrails, risers and treads. In addition, a section of the platform would be raised and tactile warning strips would be installed at the platform edges. As preliminary engineering progresses, if it appears that operational and/or engineering constraints limit direct street-level ADA accessibility to the 23 platform, indirect accessibility via the Entry Facility could be achieved by installation of an elevator, enabling the platform of the 23 to become connected to the Entry Facility via the AC platform. This option reduces the number of elevators required to make the 23 line accessible by eliminating the need for the 23 mezzanine to AC mezzanine elevator as described under the 23 Fulton Street Station rehabilitation discussion above.

AC and J M Z Mezzanine Improvements

In Alternative 9, improvements would be made to the mezzanines and platform access at the AC line Broadway - Nassau Station and J M Z line Fulton Street Station would improve circulation and reduce overcrowding conditions.

The AC mezzanine would be improved by widening the mezzanine under Fulton Street between Nassau Street and Broadway, extending underneath the eastern half of Broadway. This would be achieved by eliminating the existing ramp systems and replacing with additional vertical capacity inside the Entry Facility, providing improved pedestrian flow and wayfinding and creating a connected, uniform, high quality environment throughout the FSTC. By removing the ramp systems, the reconfigured AC mezzanine spaces would provide connections between the AC line at the lowest level of the Entry Facility and the 45, J M Z and 23 lines at higher levels, facilitating convenient transfer and wayfinding. ADA accessibility would be achieved by raising the center portion of the platform to provide train access for customers in wheelchairs, and by providing elevators.

West AC mezzanine

To provide adequate levels of service, the AC mezzanine west of the J M Z Nassau Street line would be widened to provide a direct connection with the Entry Facility. Platform stairs would be oriented toward the Entry Facility to improve circulation (one (1) existing stair requires reorientation), and the roof would be reconstructed over the widened mezzanine. The existing upper mezzanine corridor and support facilities would be removed. Existing support facilities would be relocated, and the interior ramps and landings would be removed. This would allow for a consistent floor elevation to be established throughout this entire side of the mezzanine, which would connect directly into the Entry Facility. The westernmost end of the lower mezzanine would be closed, as transfers from the southbound side of the 45 Fulton Street Station would be made through a new escalator/stair/elevator bank and passageway below the 45 Fulton Street Station, which would guide customers into the new Entry Facility.

East AC mezzanine

The area of the AC mezzanine east of Nassau Street and the J M Z line would be reconfigured to complement the reconfiguration of the AC mezzanines. This would be accomplished by installing escalators and widening existing stairs and the removal of the ramps at the AC mezzanine to establish

one (1) mezzanine floor level on either side of the **J M Z**. This reconfiguration would provide more direct access between the **J M Z** line and the **A C** mezzanine and would increase stair capacity to the street. The northbound platform would be accessed directly from the **A C** west mezzanine via ramps. Escalators and stairs would provide access to the northbound mezzanine above. At the southbound **J M Z** line escalators and stairs would provide access to the platform directly from the east **A C** mezzanine. The **J M Z** platforms would be made ADA accessible from the Entry Facility. In addition, a street to platform elevator providing access to the **A C** mezzanine and northbound **J M Z** would be located on the north-east corner of Nassau and Fulton Streets at 129 Fulton Street. The existing stair at this location would be removed.

Both new mezzanine spaces would be similar in finish, height and quality to the Central Station Concourse, establishing a coherent and unified environment throughout the Fulton Street Entry Facility. The reconfiguration would remove the existing ramps in both spaces. One of the many benefits of this reconfiguration would be to provide at least two (2) new staircase connections between the **A C** platform at three (3) levels below the street, and two (2) levels below the street, respectively. The addition of these staircases would open up the mezzanine to the platform, visually reinforcing the vertical connection and substantially improving the flow for the **A C** line. It would also clarify wayfinding on both sides of the **J M Z**.

A new stairway is proposed to connect the Fulton Street Station **2 3** platform directly with the **A C** platform. This would facilitate transfers between the two (2) lines, as well as avoid the need for passengers transferring to the **2 3** lines from the **4 5** or **J M Z** northbound to make as many level changes as required by the existing configuration. The stairs would rise directly from the east end of the **A C** platform, and then split into two (2) stairs accessing the **2 3** platforms.

Pedestrian and Passenger Connection Between **R W** and **E** Service

This paid-zone connector would run beneath the western sidewalk of Church Street, linking the northern end of the southbound platform of the **R W** line Cortlandt Street Station with the southern end of the **E** line terminal at the WTC, and would include a new transfer between **R W** platforms provided in the Dey Street Passageway (see Figure 3-9).

It would improve west side access to Lower Manhattan and improve operational flexibility by permitting customers to transfer between the subway services without payment of additional fares.

Improved Street Access to the Subway

Alternative 9 would include improved subway access, including wider and more direct stairways, escalators, elevators (providing ADA access), and new street entrances.

As part of the FSTC, street access improvements are proposed to facilitate ingress and egress at several locations. The current design approach is to install street-level stairs at the locations with the most sidewalk space, and to avoid utilities and ventilators wherever possible. Proposed locations are as follows:

Dey Street and Broadway

The Dey Street Access Plaza on the west side of Broadway would include a new stairway, escalator and ADA elevator access vertical core. This vertical core would connect the street, the **4 5** line Fulton Street Station southbound platform, and the lower passageway.

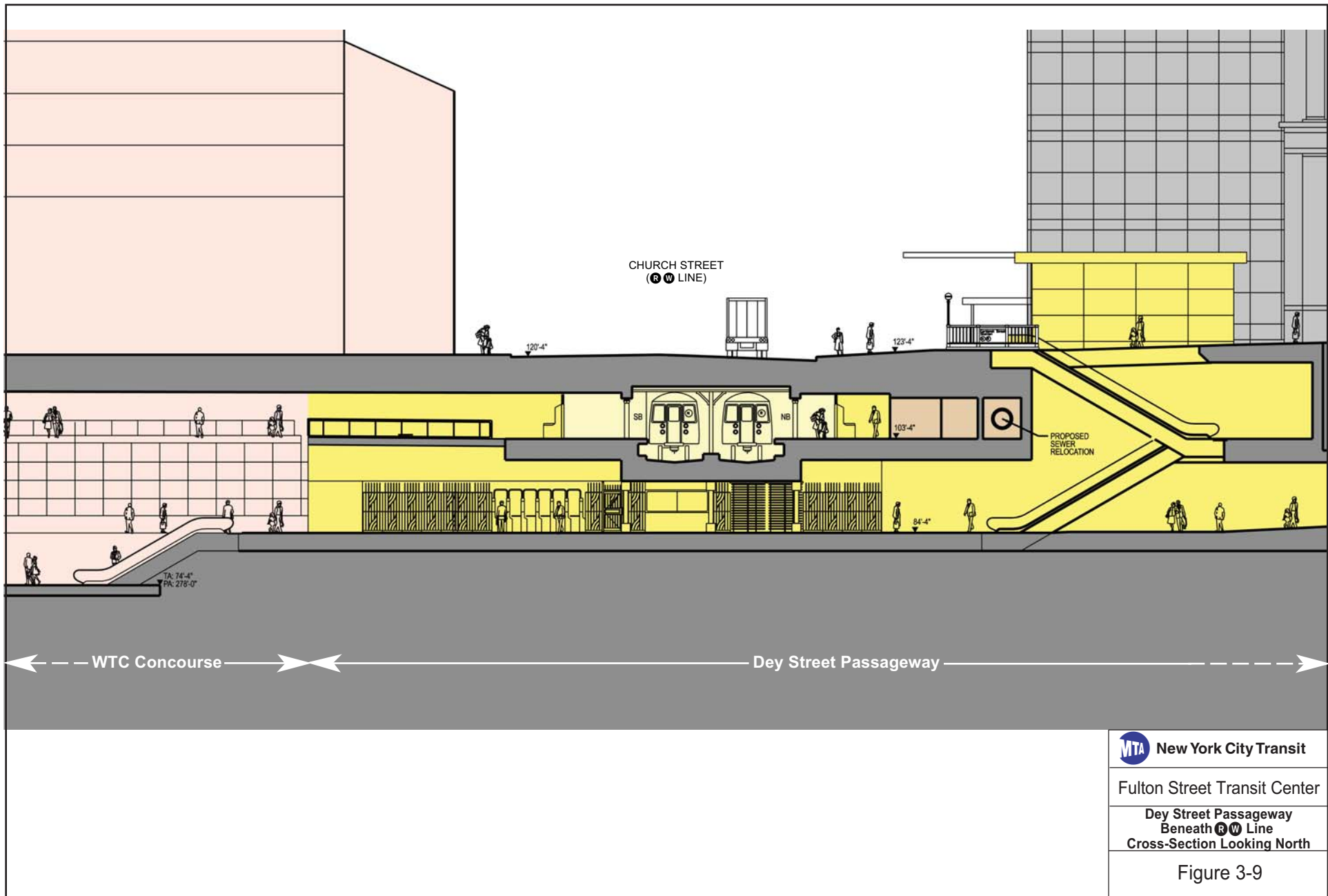

Dey and Church Streets (Northeast Corner)

As part of the Dey Street Passageway, an improved entrance would be provided from the street to the **R W** Cortlandt Street Station and the new passageway. This entrance would be located at the northeast corner of Dey and Church Streets, utilizing a previously reserved space in the basement of the Millennium Hotel and descending to the **R W** platform level and the passageway below. A new elevator would be provided at Dey and Church Streets from the eastern sidewalk along Church Street down to the northbound **R W** platform and Dey Street Passageway.

195 Broadway Basement

A new set of escalators and stairs linking the Entry Facility with the southbound **4 5** Fulton Street Station platform would be provided in the basement of the building located at 195 Broadway. These facilities would improve both street access and the busy transfer between the **4 5** and **A C** services, and would move the connection to the center of the platform to alleviate platform overcrowding.

The new passageway in the basement of 195 Broadway would connect from the middle of the lower FSTC circulation area (two (2) levels below street-level), with the southbound **4 5** platform via three (3) escalators, a stair and an elevator. This would terminate on the southbound **4 5** platform just north of its midpoint, improving the overall distribution of passengers on the platform. The circulation requirements to support this would require incursion into the basement of 195 Broadway to maintain platform widths, provide sufficient vertical circulation, and support the addition of an ADA elevator.

An improved entrance would be provided at the south end of the southbound platform of the **4 5** Fulton Street Station at Cortlandt Street, utilizing an easement previously reserved at One Liberty Plaza.

New stairs from street-level to the **4 5** line on the east and west sides of Broadway at Cortlandt Street

New stairs would be constructed to improve access to the northbound and southbound **4 5** platforms. Street-level stairs are proposed at the locations with the most sidewalk space which would avoid utilities and ventilators wherever possible. The south ends of the platform would be widened toward the property lines of the adjacent buildings to allow space for control areas and queuing. The existing platform level rooms would be relocated to the south to accommodate the necessary platform space. At the southbound side, a passageway would need to be constructed below the existing active driveway at One Liberty Plaza. Once this passage is south of the driveway, a stair would be constructed up to the street using an existing easement. The stair to the northbound platform would link to the sidewalk at the corner of Broadway and Maiden Lane.

FSTC Street Entrance Improvements

Street-level access would be reconfigured throughout the FSTC to improve pedestrian flow, including improvements to subway entrances at Fulton and Nassau Streets; Fulton and William Streets; and John and William Streets. There is an opportunity to provide glass sidewalk blocks above some of these control areas and above the southbound stair passageway to allow for natural daylight to illuminate these areas. This would also improve passengers' sense of safety and security as well as aid in wayfinding due to the increased levels of light.

3.4.3 ALTERNATIVE 10

Alternative 10 consists of the construction and operation of a rehabilitated, reconfigured and enhanced multi - level, subsurface station complex in Lower Manhattan that would serve 12 NYCT subway lines (see Figure 3-10). The proposed FSTC, an integrated complex of four (4) subway stations and associated connecting corridors, includes improved platforms, mezzanines and connection corridors, and a new Central Station Concourse, with a surface presence distinguished by a street-level Entry Facility on

Broadway. Alternative 10 structurally and operationally links the Entry Facility with the Corbin Building, and would require the acquisition of the Corbin Building, following coordination with SHPO. The FSTC would extend subsurface from the Existing Complex westward one (1) block to Church Street through a new pedestrian passageway below Dey Street. This passageway would connect to the future concourse at the WTC site, from which access to a variety of transit options similar to those existing pre-September 11 is anticipated to be available. The FSTC, by virtue of its many subway connections to commuter hubs such as Grand Central Terminal, Pennsylvania Station, the Permanent WTC PATH Terminal and Atlantic Terminal, would also form a key access point for workers coming to Lower Manhattan from Long Island, Westchester County and New Jersey using commuter rail. The elements constituting Alternative 10 are described in detail below (see Figure 3-11).

ENTRY FACILITY

Alternative 10 would include a new prominent Entry Facility at the street and subsurface levels, centrally located on Broadway between Fulton and John Streets. The Entry Facility would integrate horizontal connectivity between the **A C** and **4 5** service with vertical connectivity between the street and different level, and provide improve street-level access and integration with the Corbin Building.

At street-level, the Entry Facility would be located on the east side of Broadway between Fulton and John Streets, extending approximately 160 feet eastward into the block. Relative to the subway, the Entry Facility would be located at the intersection of the **4 5** and **A C** lines and in close proximity to the **J M Z** station. The Entry Facility would enhance overall connectivity and provide a prominent new civic structure as the principal entrance to the subway system and to public spaces subsurface. It would incorporate a street-level structure and subsurface Central Station Concourse. The Entry Facility would serve as a highly visible focal point of subway transit in Lower Manhattan, replacing multiple hard-to-locate entrances with prominent entrances on Broadway and additional entrances on Fulton and John Streets. It would provide a major connection node for the subway system, offering maximum utility for both passengers and pedestrians.

The Entry Facility would be designed to provide a large open space that would use natural light and direct views wherever possible to enhance wayfinding with minimal reliance on signage. To improve wayfinding, the interior design would be consistent in character throughout the facility, establishing a unified visual environment throughout all elements of the FSTC. Existing transfers between the **4 5** and **A C** lines would be greatly improved. New escalators and stairways would provide convenient access and reduce congestion, providing a consistent standard of service in accordance with demand. Access to the **4 5** southbound platform would be augmented by a proposed new street entrance structure at Broadway and Dey Street - the Dey Street Access Plaza, at 189 Broadway.

Vertical transition within the Entry Facility would be provided using escalators and new stairways, which would be sized according to projected passenger volume and could be directed in response to anticipated flow. Elevators would be provided to make the **4 5**, **A C** and **J M Z** platforms and unpaid levels ADA accessible.

From the street-level down, the Entry Facility would be vertically organized on four (4) levels as follows (see Figure 3-12):

Street entry level – This level would include entrances from the street into an enclosed major public space that would provide open and direct access to lower levels, and would be designed to aid visibility and wayfinding among subway lines. Main entrances along Broadway and Fulton Street would open into the Entry Facility with clear sightlines into the Central Station Concourse below. Access to the Entry Facility would also be provided via the Corbin Building from John Street (see Figure 3-13). Limited retail and ancillary activities may be provided at this level.

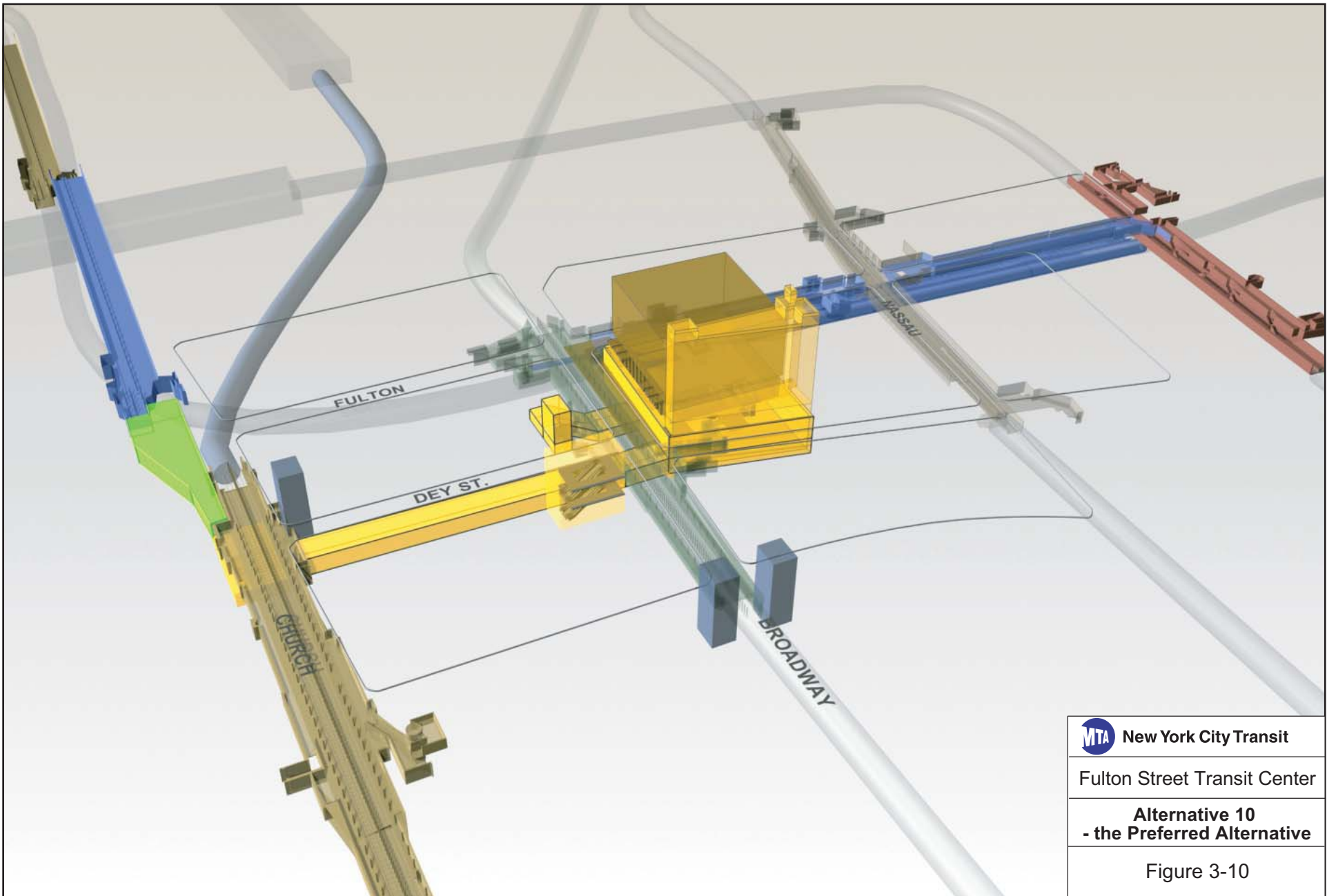

 New York City Transit
Fulton Street Transit Center
Alternative 10 - the Preferred Alternative
Figure 3-10

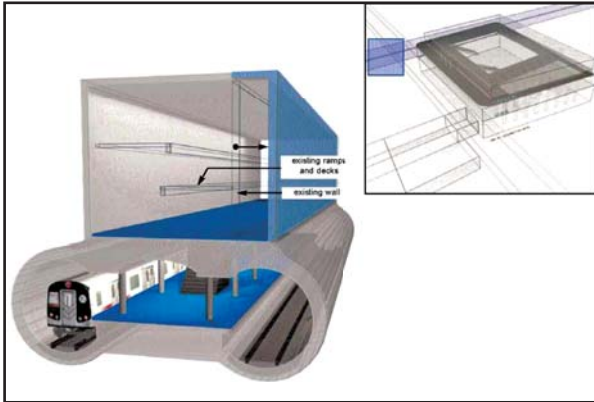

Clear out existing **A** **C** mezzanine and widen.

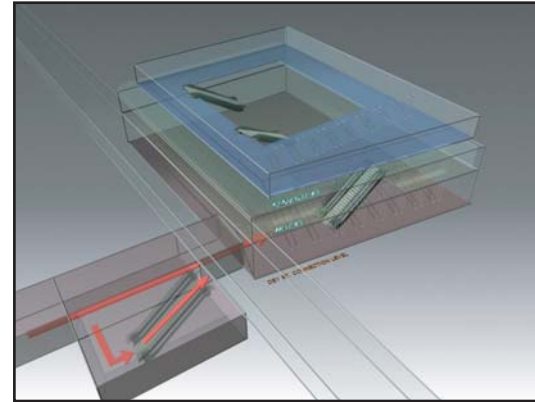

Dey Street Passageway with access straight through, under Corbin Building.

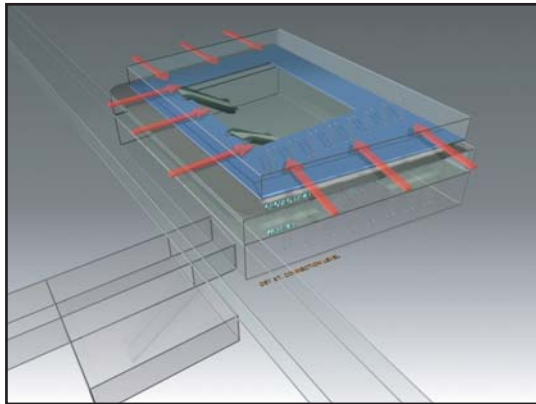

Continuous street-level access around perimeter.

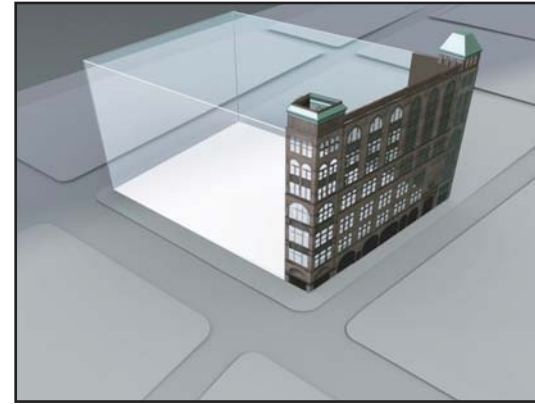

Corbin Building Adaptive Reuse - use Corbin Building basement and street-level for Central Station Concourse and street access.

Legend

- Unpaid Circulation
- Paid Circulation
- Support Facilities
- NYCT Operations
- Retail



Street-Level Plan



4 5 Platform Level Plan



Concourse Level Plan

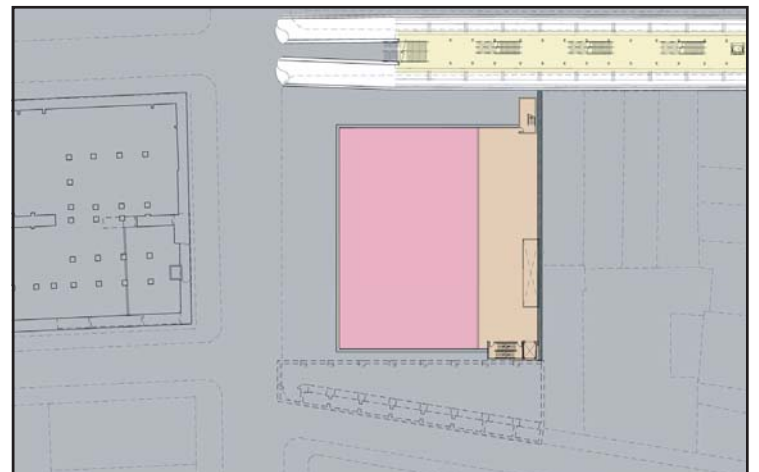

A C Platform Level Plan



Figure 3-13: Corbin Building seen from John Street under the Preferred Alternative.

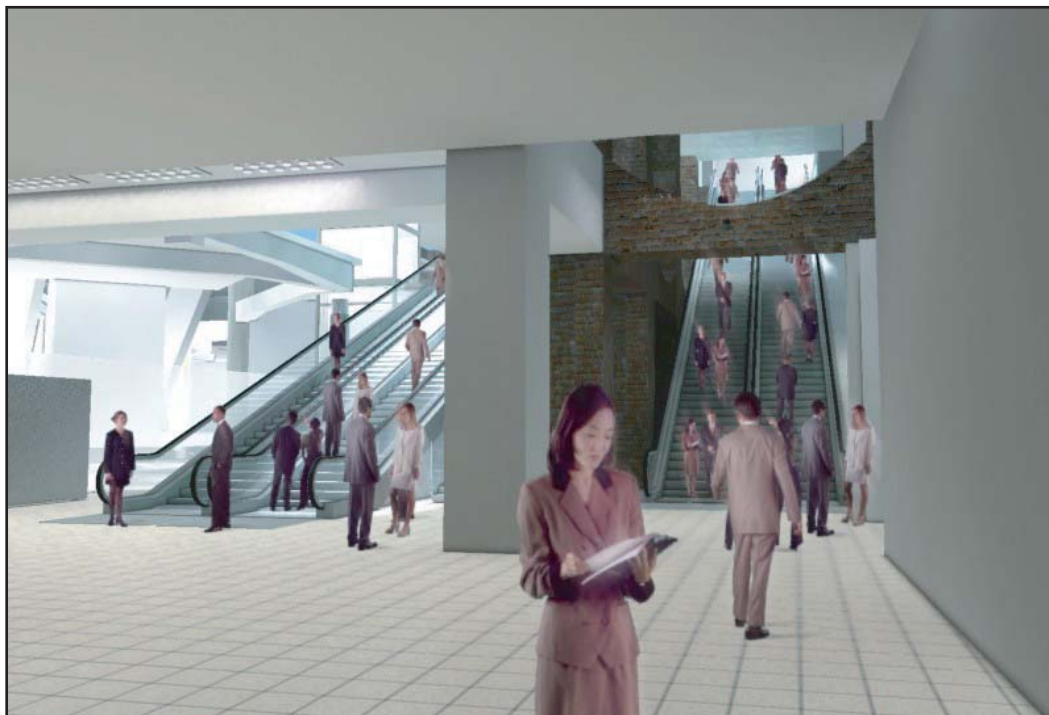

Figure 3-14: Dey Street Passageway Connection to Entry Facility Under the Preferred Alternative.

One (1) level below street-level – Entry Facility Central Station Concourse and 4 5 Platform Level: This level would be linked to the street-level above via elevator, escalators and/or stairs, and would provide direct access to the subway 4 5 northbound platform at the same level and to the new station concourse one (1) level subsurface. Similarly to the street-level, retail and ancillary activities would be limited on this level. This level would provide an ideal location for transit information services and a visitors' center, as it would be visible to both transferring passengers and those entering and exiting the system.

Two (2) levels below street-level – Dey Street Passageway and A C mezzanine level: This level includes the A C mezzanine, a new link from the 4 5 southbound platform and access to the proposed Dey Street Passageway. This would also result in improved access to the J M Z and 2 3 lines. To accommodate necessary structural clearances, this level would incorporate a level change of approximately six (6) feet between the A C mezzanine and Dey Street Passageway. To limit potential disruptions, this transition level is positioned away from the A C mezzanine, so that passengers transferring to the northbound 4 5 still have easy access up to both the north and south ends of the uptown platform.

Three (3) levels below street-level – Equipment Room Level: This partial level would include the basement of the Entry Facility, which houses support facilities and equipment. Although not accessible at this level, the A C platform would be at the same elevation.

From the street-level up, the Entry Facility would be organized on as many as five (5) levels, depending on the final design. These would be open mezzanines surrounding the central open space and would be designed to allow views among all levels within the Entry Facility and Central Station Concourse, and maintain natural light from the highest level down through the Facility. All levels would be served by internal escalators and/or stairways. The levels would be organized as follows:

One (1) level above street-level – Mezzanine Level: This level would be approximately 20 feet above street-level to ensure open views between the Entry Facility and the surrounding streets. It would be used for public amenity and could include both exhibition and retail space.

Two (2) levels above street-level – Upper Mezzanine Level: This level would be used for public amenity and could include both exhibition and retail space.

Three (3) levels above street-level – Mechanical Equipment Level: This level would be designated as a service floor. By positioning equipment in self-contained boxes within the perimeter, mechanical equipment could be acoustically isolated and could be maintained with limited disruption to activities in the Entry Facility below. The placement of mechanical equipment at this level would also allow the rooftop to be made available for publicly accessible activities. It is intended that the equipment would be housed behind the building's layered façade, maintaining the appearance of a continuous streetwall from the surrounding streets.

It is proposed that the Corbin Building would be fully integrated with the FSTC Entry Facility at street-level and also subsurface. Although the design is still at the conceptual stage, it is anticipated that connections between the Corbin Building and the Entry Facility would be created at all levels, allowing for access to the Entry Facility via entrances into the Corbin Building and increasing public access to the historic features of the Corbin Building. The extent of public accessibility to street-level and above would be dependent on the final design of Alternative 10.

The acquisition and adaptive reuse of the Corbin Building would be implemented based on close cooperation and consultation with SHPO. Such consultation began early in the planning stages of the FSTC and is ongoing. Following acquisition of the Corbin Building, a historical assessment of the building would be required, using mapping and non-invasive testing to determine the authenticity of potential historic features. Under the guidance of an historic preservation expert, restoration of historic

features, including repairs and cleaning, would be performed. An assessment would be made of current life safety systems within the building, with upgrades being evaluated to ensure compliance with current requirements for historic structures.

DEY STREET PASSAGEWAY

A new pedestrian passageway is proposed under Dey Street between Broadway and Church Street connecting the Entry Facility to the WTC site. Starting at the Entry Facility at two (2) levels below street-level, this unpaid passageway would extend west, cross under the 4 5 line, and continue west under Dey Street to Church Street at the R W line Cortlandt Street Station. The proposed Dey Street Passageway would connect to the WTC site via the existing R W underpass, which would be widened (see Figure 3-9). The passageway would include stairway and ADA elevator connections to the northbound and southbound R W platforms. At its western end, the Passageway would be fully integrated with the redevelopment of the WTC site; a detailed design will be coordinated with WTC plans as these are developed.

The Dey Street Passageway would include a new entrance structure at the southwest corner of Broadway at Dey Street - the Dey Street Access Plaza. It would serve as an entrance to the 4 5 southbound platform and the Dey Street Passageway. The existing property, 189 Broadway, would be acquired and the two (2)-story building demolished to accommodate construction of the Dey Street Access Plaza. The Dey Street Access Plaza is proposed as an open plaza formed by the placement of a rear vertical glass surface on the south boundary and a horizontal glass canopy overhead. The vertical surface will direct natural and artificial reflective light to the lower levels. The horizontal glass canopy would be hung from the vertical wall with a cable suspension system providing shelter and natural illumination over the stairway and escalators which access the Dey Street Passageway and FSTC Entry Facility. The design of the Plaza will be enhanced by glass benches and bollards providing an area of public seating on Broadway (please see Figures 3-7 and 3-8). The new structure would be comprised of a protective canopy over the street entrances and two (2) levels of vertical circulation elements subsurface. It would also house ADA access and mechanical equipment.

Additional street entrances to the Dey Street Passageway would be provided on the north side of Dey Street at the Millennium Hotel on Church Street. All four (4) of the existing entrances to the subway system at the intersection of Church and Dey Streets would be renovated or reconstructed.

The Dey Street Passageway is currently proposed to be an unpaid connection between the WTC site and the FSTC and, as such, is expected to serve a larger volume of people than if it were strictly a paid-zone to paid-zone transfer between the FSTC and the E and R W subway lines. The Dey Street Passageway would allow pedestrians to avoid crossing Church Street and Broadway, both of which are busy vehicular arterials.

Under Alternative 10, the Dey Street Passageway would enter the Entry Facility beneath the Corbin Building (see Figure 3-14), extending below the building and require underpinning of the Corbin Building. Part of the lateral support for the Corbin Building would be provided by the structural integration with the new Entry Facility. Subsurface, in addition to essential underpinning, a new perimeter wall would be constructed at the south end of the Corbin Building as a permanent retaining system. The alignment would be organized so that the passageway would enter the Entry Facility on a straight axis with the majority of vertical circulation taking place in a top lit space within the renovated Corbin Building basements.

STATION REHABILITATION

Alternative 10 includes the rehabilitation of the 4 5 line Fulton Street Station and the 2 3 line Fulton Street Station. These improvements would include station repairs and upgrading, as well as new elevators to make the platforms accessible to disabled passengers. New street access is proposed for the 4 5 line on both northbound and southbound platforms at the southern ends. Several improvements are proposed

to address ADA requirements, including a new elevator at the northern end of the southbound 4 5 platform and an additional new elevator between the A C platform, lower mezzanine and upper mezzanine levels. These improvements would make the 4 5 line, A C line Broadway - Nassau Station and transfers between them ADA accessible. The existing 4 5 platforms of the Fulton Street Station may be reconfigured and opened to the mezzanine level of the new Entry Facility.

In considering these improvements, as well as those envisioned for functional upgrading and integration with the Entry Facility, the historical character of the stations would be taken into consideration and efforts to preserve or re-use historical elements would be included in the design.

4 5 Line Fulton Street Station

This station was constructed as part of the Rapid Transit Subway Construction Company's project for the first subway system in New York and was opened on January 16, 1905. Because of its historical significance, the station's original platform containing mosaic wall tiles, marble and terra cotta retains historic landmark status. This station would be rehabilitated with the goal of preserving as much of this historic fabric as possible, while at the same time modernizing the station to meet the current and future needs of NYCT and its passengers.

Existing passenger congestion would be remedied through the integration of the 4 5 and A C Fulton Street Station with the Entry Facility. Through the Entry Facility, improved connections would be provided to both the northbound and southbound platforms. For example, by increasing the easement into 195 Broadway, a new 4 5 underpass has been proposed via a bank of escalators, stairs and an elevator. This would increase the LOS for transferring customers, and would replace the current connection between the southbound 4 5 and the A C mezzanine. In addition, all existing control areas on the northbound side of the station would be eliminated due to their incorporation into the Entry Facility. This would permit parts of the east wall of the 4 5 platform to be selectively removed while opening up the majority of the northbound platform to the Entry Facility, and accounting for historical features of the station.

A proposed control area at Dey Street and Broadway would allow a larger passenger volume to enter and exit the 4 5 southbound platform and the Dey Street Passageway via another bank of escalators, stairs and an elevator. At the south end of the station, both platforms would be widened, and new street-level stairs would be installed. This would not only provide for a more inviting and safer space than currently exists, but it would also help to relieve some passenger congestion at the platform during the construction phase.

All of the work described above would comply with the NYCT Station Planning and Design Guidelines. These guidelines include requirements that stations are brought to a state of good repair, including replacement of the existing floor finish with new tiles, replacement or restoration of the existing mosaic tile bands that are faded or damaged, and repainting of all exposed steel and concrete within the station. Existing structural and water infiltration deficiencies are identified and remedied.

2 3 Line Fulton Street Station

The rehabilitation of the 2 3 Fulton Street Station would ensure that the station is brought to a state of good repair (in accordance with the NYCT Station and Planning Design Guidelines discussed above). This would include replacement of the existing floor finish with new tiles, replacement or restoration of the existing mosaic tile bands that are faded or damaged, and repainting of all exposed steel and concrete within the station.

This station is accessed via two (2) sidewalk street stairs on Fulton Street and three (3) private property stairs, two (2) at 110 William Street (one (1) of which is accessed via the John Street side of the building), and one (1) at 130 William Street. The smaller mezzanine, which is to the north of Fulton Street, is an

“exit only” mezzanine that requires passengers to traverse a long corridor through a building before reaching the stairs up to the street. This north mezzanine is in poor condition and does not have adequate signage or wayfinding devices.

As part of the rehabilitation, a connecting passageway and stairs would be constructed between the platform level of the **A C** line and the platform level of the **2 3** line, providing a direct transfer connection and an additional means of egress from the **A C** platform. This connection would relieve some of the congestion that would occur as a result of the construction work at the mezzanine levels above. A new elevator would be constructed from street to mezzanine level using an existing easement within 135 William Street to provide a direct connection from the **2 3** platform to the **A C** platform. A new entrance from street level to the **2 3** Fulton Street Station would also be constructed within 150 William Street.

ADA compliance at the station would be achieved through appropriate installation of elevators and modification of all stairs to comply with the Americans with Disabilities Act. This would include new handrails, risers and treads. In addition, a section of the platform would be raised and tactile warning strips would be installed at the platform edges. If operational and/or engineering constraints limit direct street - level ADA accessibility to the **2 3** platform, indirect accessibility via the Entry Facility could be achieved by installation of an elevator, enabling the platform of the **2 3** to become connected to the Entry Facility via the **A C** platform. This option reduces the number of elevators required to make the **2 3** line accessible by eliminating the need for the **2 3** mezzanine to **A C** mezzanine elevator as described under the **2 3** Fulton Street Station rehabilitation discussion above.

A C and J M Z Mezzanine Improvements

Alternative 10 would include improvements to the mezzanines and platform access at the **A C** line Broadway - Nassau Station and **J M Z** line Fulton Street Station, would improve circulation and reduce overcrowding conditions.

The **A C** mezzanine would be improved by widening the mezzanine under Fulton Street between Nassau Street and Broadway, extending underneath the eastern half of Broadway. This would be achieved by eliminating the existing ramp systems and replacing with additional vertical capacity inside the Entry Facility, providing improved pedestrian flow and wayfinding and creating a connected, uniform, high quality environment throughout the FSTC. By removing the ramp systems, the reconfigured **A C** mezzanine spaces would provide connections between the **A C** line at the lowest level of the Entry Facility and the **4 5**, **J M Z** and **2 3** lines at higher levels, facilitating convenient transfer and wayfinding. ADA accessibility would be achieved by raising the center portion of the platform to provide train access for customers in wheelchairs and the installation of elevators.

West A C mezzanine

To provide adequate LOS, the **A C** mezzanine west of the **J M Z** Nassau Street line would be widened to provide a direct connection with the Entry Facility. Platform stairs would be oriented toward the Entry Facility to improve circulation one (1) existing stair requires reorientation), and the roof would be reconstructed over the widened mezzanine. The existing upper mezzanine corridor and support facilities would be removed. Existing support facilities would be relocated and the interior ramps and landings would be removed. This would allow for a consistent floor elevation to be established throughout this entire side of the mezzanine, which would connect directly into the Entry Facility. The westernmost end of the lower mezzanine would be closed, as transfers from the southbound side of the **4 5** platform would be made through a new escalator/stair/elevator bank and passageway below the **4 5** Fulton Station, which would guide customers into the new Entry Facility.

East **A C mezzanine**

The area of the **A C** mezzanine east of Nassau Street and the **J M Z** line would be reconfigured to complement the reconfiguration of the west **A C** mezzanines. This would be accomplished by installing escalators and widening existing stairs and the removal of the ramps at the **A C** mezzanine to establish one (1) mezzanine floor level on either side of the **J M Z**. This reconfiguration would provide more direct access between the **J M Z** line and the **A C** mezzanine and would increase stair capacity to the street. The northbound platform would be accessed directly from the **A C** west mezzanine via ramps. Escalators and stairs would provide access to the northbound mezzanine above. At the southbound **J M Z** line, escalators and stairs would provide access to the platform directly from the east **A C** mezzanine. The **J M Z** platforms would be made ADA accessible from the Entry Facility. In addition, a street to platform elevator providing access to the **A C** mezzanine and northbound **J M Z** would be located on the north-east corner of Nassau and Fulton Streets at 129 Fulton Street. The existing stair at this location may be removed.

Both new mezzanine spaces would be similar in finish, height and quality to the Central Station Concourse, establishing a coherent and unified environment throughout the Entry Facility. The reconfiguration would remove the existing ramps in both spaces. One of the many benefits of this reconfiguration would be to provide at least two (2) new staircase connections between the **A C** platform at three (3) levels below the street, and two (2) levels below the street, respectively. The addition of these staircases would open up the mezzanine to the platform, visually reinforcing the vertical connection and substantially improving the flow for the **A C** line. It would also clarify wayfinding on both sides of the **J M Z**.

A new stairway is proposed to connect the Fulton Street Station **2 3** platform directly with the **A C** platform. This would facilitate transfers between the two (2) lines as well as avoid the need for passengers transferring to the **2 3** lines from the **4 5** or **J M Z** northbound to make as many level changes as required by the existing configuration. The stairs would rise directly from the east end of the **A C** platform and then split into two (2) stairs accessing the **2 3** platforms.

A Pedestrian and Passenger Connection Between **R W** and **E** Service

This paid-zone connector would run beneath Church Street, linking the northern end of the southbound platform of the **R W** line Cortlandt Street Station with the southern end of the **E** line WTC terminal, and would include a new transfer between **R W** platforms provided in the Dey Street Passageway (see Figure 3-7). It would improve west side access to Lower Manhattan and improve operational flexibility by permitting customers to transfer between the services without payment of additional fares.

Improved Street Access to the Subway

Alternative 10 would include improved subway access, including wider and more direct stairways, escalators, elevators (providing ADA access), and new street entrances.

As part of the FSTC, street access improvements are proposed to facilitate ingress and egress at several locations. The current design approach is to install street-level stairs at the locations with the most sidewalk space, and to avoid utilities and ventilators wherever possible. Figure 4-1, Chapter 4, illustrates the proposed new entrance locations. Proposed locations are as follows:

Dey Street and Broadway

The Dey Street Access Plaza on the west side of Broadway would include a new stairway, escalator and ADA elevator access vertical core. This vertical core would connect the street, the **4 5** line Fulton Street Station southbound platform and the lower passageway.

Dey and Church Streets (Northeast Corner)

As part of the Dey Street Passageway, an improved entrance would be provided to the **R** **W** Cortlandt Street Station and the passageway. This would be located at the northeast corner of Dey and Church Streets, utilizing a previously reserved space in the basement of the Millenium Hotel and descending to the **R** **W** platform level and the passageway below. A new elevator would be provided at Dey and Church Streets from the eastern sidewalk along Church Street down to the northbound **R** **W** platform and Dey Street Passageway.

195 Broadway Basement

A new set of escalators and stairs linking the Entry Facility with the southbound **4** **5** Fulton Street Station platform would be provided in the basement of the building located at 195 Broadway. These facilities would improve both street access and the busy transfer between the **4** **5** and **A** **C** services, and would move the connection to the center of the platform to alleviate platform overcrowding.

The new passageway in the basement of 195 Broadway would connect from the middle of the lower FSTC circulation area (two (2) levels below street-level), with the southbound **4** **5** platform via three (3) escalators, a stair and an elevator. This would terminate on the southbound **4** **5** platform just north of its midpoint, improving the overall distribution of passengers on the platform. The circulation requirements to support this would require incursion into the basement of 195 Broadway to maintain platform widths, provide sufficient vertical circulation and support the addition of an ADA elevator.

An improved entrance would be provided at the south end of the southbound platform of the **4** **5** Fulton Street Station at Cortlandt Street, utilizing an easement previously reserved at One Liberty Plaza.

*****4** **5** Northbound Platform Beneath John Street - New Platform Stairs***

A new stairway at the northbound **4** **5** platforms beneath John Street would provide access from the southern end of the platform to the street. A fare control line at the bottom of the stairway would serve as an exit to the Dey Street Passageway and Central Station Concourse in the morning rush hour. The existing fare control at the northbound platform, the existing sidewalk stairway on the south side of John Street and the existing easement stairway on the north side of John Street would be eliminated. The elimination of these street stairways would greatly improve sidewalk circulation.

New stairs from street-level to the **4** **5** line on east and west sides of Broadway at Cortlandt Street

New stairs would be constructed to improve access to the north and southbound **4** **5** platforms. Street-level stairs are proposed at the locations with the most sidewalk space which would avoid utilities and ventilators wherever possible. The south ends of the platform would be widened toward the property lines of the adjacent buildings to allow space for control areas and queuing. The existing platform level rooms would be relocated to the south to accommodate the necessary platform space. At the southbound side, a passageway would need to be constructed below the existing active driveway at One Liberty Plaza. Once this passage is south of the driveway, a stair would be constructed up to the street using the existing easement. The stair to the northbound platform would link to the sidewalk at the corner of Broadway and Maiden Lane.

FSTC Street Entrance Improvements

Street-level access would be reconfigured throughout the FSTC to improve pedestrian flow, including improvements to subway entrances at: Fulton and Nassau Streets; Fulton and William Streets; and John and William Streets. There is an opportunity to provide glass sidewalk blocks above some of these control areas and above the southbound stair passageway to allow for natural daylight to illuminate these

areas. This would also improve passengers' sense of safety and security as well as aid in wayfinding due to the increased levels of light.

3.5 SUMMARY OF COMPARATIVE FEATURES OF FULL BUILD ALTERNATIVES

In many respects, Alternative 9 and Alternative 10 are similar. Their differences are directly related to the way each alternative engages the Corbin Building.

Alternative 10 allows for a larger Central Station Concourse because it extends into the basement of the Corbin Building. Alternative 9 has a smaller Central Station Concourse, as it does not extend into the Corbin Building. Alternative 9 does not include a direct connection from the FSTC to John Street (as included in Alternative 10); it may require an additional street stair to be built connecting the Dey Street Passageway to John Street. Alternative 10 provides street access from John Street through the ground level of the Corbin Building, while such access is blocked by the Corbin Building in Alternative 9. Alternative 9 does not allow for public access from the subway to the Corbin Building, which would be possible under Alternative 10.

There is a difference of approximately 11,000 square feet of potential retail space between Alternative 9 and the larger Alternative 10. Existing retail space is as follows:

- 189 Broadway: 9,242 square feet
- 192 Broadway: 5,000 square feet
- 194-196 Broadway: 21,339 square feet
- 198 Broadway: 3,000 square feet
- 200-202 Broadway: 7,690 square feet
- 204-210 Broadway: 9,973 square feet

This total area of 56,244 square feet of existing retail space would be reduced to 13,530 square feet under Alternative 9, and to 24,530 square feet under Alternative 10. Alternative 9 includes less retail space than Alternative 10 due to the need to include transit operational facilities within the Entry Facility under Alternative 9; under Alternative 10 these operational facilities would be located within the Corbin Building, thereby providing more space for retail in the Entry Facility. The concept level investment cost for Alternative 10 is greater than that for Alternative 9; this added cost is less than 15 percent. Both Alternatives address the project goals and the Project Purpose and Need and have been advanced for further analysis in this FEIS, along with the No Action Alternative.

Under Alternative 9, pedestrians could not enter the Entry Facility on John Street or Broadway via the Corbin Building. Pedestrians would have to use either the Dey Street Passageway west of Broadway or walk around the northeast corner of Broadway and John Street, resulting in higher pedestrian volumes in these areas. As a result, a few locations are projected to operate at a better LOS in Alternative 10 than Alternative 9. In 2008, the south crosswalk at the Broadway and Dey Street intersection is projected to improve from LOS E to D during the AM peak hour and from D to B during the PM peak hour in Alternative 10. The northeast corner of Broadway and John Street is projected to improve from LOS C to B during both peak hours in Alternative 10. In 2025, the south crosswalk at the Broadway and Dey Street intersection is projected to improve from LOS E to D during the AM peak hour and from D to B during the PM peak hour in Alternative 10. The northeast corner of Broadway and John Street is projected to improve from D to B during the AM peak hour and from LOS C to B during the PM peak hour in Alternative 10.

In 2025 under Alternative 9, pedestrians using the Dey Street Passageway would reduce their travel time between Church Street and Broadway in comparison to walking at street level such as in the No Action Alternative.

In 2025, subway patrons would reduce their travel time going from Church Street to their destination east of Broadway by approximately 40 seconds in Alternative 9. This represents a time savings of approximately 170,943 hours per year in comparison to the No Action Alternative for all commuters combined that would benefit from this improved circulation. Non-subway patrons using the Dey Street Passageway to travel to destinations east of Broadway via John Street would still benefit from not having to cross Broadway at street-level. However, they would need to exit the Dey Street Passageway via the Central Station Concourse and then exit the Entry Facility facing Broadway and continue south and east onto John Street. The time saved by not needing to cross Broadway is counteracted by the circuitous movement through the Entry Facility in order to travel east via John Street.

Under Alternative 9, approximately 235,177 hours per year would be saved by pedestrians in comparison to the No Action Alternative for all pedestrian flows combined that would benefit from this improved circulation. Some pedestrians using the Dey Street Passageway to travel to destinations east of Broadway via John Street would still benefit from not having to cross Broadway at street - level. However, they would need to exit the Dey Street Passageway via the Central Station Concourse, exit the Entry Facility east of Broadway, and walk west and south at street level onto John Street. The time saved by not crossing Broadway at street - level is nullified by the circuitous movement through the Entry Facility in order to travel east on John Street. Some pedestrians using the Dey Street Passageway to travel to destinations east of Broadway on John Street would opt to exit on the west side of Broadway and cross Broadway at street - level since the average travel times via the Entry Facility or via crossing Broadway (with traffic lights) are projected to be approximately equivalent.

In 2025 under Alternative 10, pedestrians using the Dey Street Passageway would reduce their travel time between Church Street and Broadway in comparison to walking at street level such as in the No Action Alternative.

Under Alternative 10, approximately 258,049 hours per year would be saved by pedestrians in comparison to the No Action Alternative for all pedestrian flows combined that would benefit from this improved circulation. Pedestrians using the Dey Street Passageway to travel to destinations east of Broadway via John Street would still benefit from not having to cross Broadway at street-level. As described above for Alternative 9, these pedestrians would exit the Dey Street Passageway via the Central Station Concourse, exit the Entry Facility east of Broadway, and walk west and south at street - level onto John Street. Alternatively, these pedestrians could exit the Dey Street Passageway on the west side of Broadway and cross Broadway at street - level.

However, Alternative 10 would provide direct access from the Dey Street Passageway via the lobby of the Corbin Building to John Street. This convenient access to destinations east of Broadway translates into an additional time savings of approximately 22,872 hours per year for pedestrians under Alternative 10 in comparison to Alternative 9.

3.6 IDENTIFICATION OF THE PREFERRED ALTERNATIVE

3.6.1 COMPARATIVE EVALUATION OF ALTERNATIVES RELATIVE TO THE PROJECT GOALS

During the preparation of the FEIS, the Alternatives presented in the DEIS were compared with regard to their fulfillment of the Project Goals, with the intent to identify a Preferred Alternative, as required by NEPA. The comparison of the Build Alternatives is presented below. The No Action Alternative was determined not to fulfill the Project Goals in the DEIS and was therefore not included in the comparative evaluation below. Alternative 10 was identified as the Preferred Alternative, for reasons described in the following pages.

Goal 1: Facilitate access, improve wayfinding and streamline transfers

Street level access will be better under Alternative 10, because the Entry Facility will be accessible from three (3) sides, including from John Street via the Corbin Building. Alternative 9, in contrast, provides access only on two (2) sides of the Entry Facility – Broadway and Fulton Street. Subsurface access from the Dey Street Passageway to John Street is also better in Alternative 10, because access is directly from the Dey Street Passageway through the Corbin Building onto Dey Street. In contrast, Alternative 9 involves a circuitous pedestrian route through the Entry Facility to arrive at John Street. Alternative 9 thus also involves more travel time than Alternative 10 between the Dey Street Passageway and John Street.

Alternative 10 provides for better street-level wayfinding than Alternative 9, because integration of the Corbin Building into the Entry Facility will give greater prominence and visibility to the Entry Facility from the street. Subsurface wayfinding will also be better in Alternative 10, because the Dey Street Passageway will open out directly to the Central Station Concourse, instead of at an angle such as in Alternative 9. The direct view of the Central Station Concourse from the Dey Street Passageway in Alternative 10 improves visibility, orientation and wayfinding.

Goal 2: Allow for intermodal connectivity (PATH, ferry service);

Connectivity between the PATH and Ferry Service and the FSTC is established through the Dey Street Passageway. The connection between the Dey Street Passageway and the Entry Facility is better in Alternative 10 than Alternative 9, because Alternative 10 provides a direct line of sight and more direct pedestrian movement through the Dey Street Passageway into the Entry Facility as a result of its continuation into the Corbin Building. Alternative 10 therefore has superior connectivity to the PATH and ferry service.

Goal 3: Promote system flexibility in the event of service disruption;

Because Alternative 10 provides for street entrances on three (3) sides, rather than two (2), as in Alternative 9, Alternative 10 has greater opportunity to provide alternative street exits to accommodate rerouted pedestrian flows from subway to street. Alternative 10 thus has greater system flexibility than Alternative 9.

Goal 4: Improve east-west pedestrian connectivity across Lower Manhattan;

Alternative 10 has better intermodal connectivity, as described above, and also better subsurface connectivity between the Dey Street Passageway and John Street because Alternative 10 provides a direct line of sight and more direct pedestrian movement through the Dey Street Passageway into the Entry Facility and the Corbin Building on John Street. As a result, overall east-west connectivity of Alternative 10 is better than Alternative 9.

Goal 5: Promote safety and reduce congestion at heavily trafficked street crossings;

Alternative 10 has better and more efficient subsurface connectivity between the Dey Street Passageway west of Broadway (a busy street) and John Street east of Broadway, as a result of its continuation into the Corbin Building. As Alternative 10 has a more efficient pedestrian connection underground between areas east and west of Broadway, pedestrians are more likely to use that connection under Alternative 10, compared to Alternative 9. The reduced number of pedestrians crossing Broadway would reduce the potential for accidents and contribute to improved traffic flow on Broadway. Alternative 10 therefore is superior to Alternative 9 in promoting safety and reduction of congestion at heavily trafficked street crossings.

Goal 6: Support current land use, recovery and rebuilding of Lower Manhattan through improved transit infrastructure, aiding the revitalization of downtown and providing the opportunity for positive local and regional benefits;

Alternative 10 is better in terms of transit infrastructure, due to the superior design of the Entry Facility with better pedestrian flow, both from street to subway and between subway lines, as described above. Alternative 10 through the acquisition and rehabilitation of the Corbin Building will also contribute to the long-term preservation of historic resources as one of the main cultural assets of Lower Manhattan that make it attractive for tourists. Superior transit access to Lower Manhattan under Alternative 10, compared to Alternative 9, will provide for a greater opportunity for positive local and regional benefits.

Goal 7: Improve travelers' experience and transit's overall attractiveness.

The goals above all contribute to the improvement of travelers' experience. Since Alternative 10 is superior to Alternative 9 in all of the goals stated above, the travelers' experience under Alternative 10 would also be better than under Alternative 9. In addition, unlike Alternative 9, which will leave the Corbin Building in its existing state, Alternative 10 would restore the historic character of the Corbin Building and would make both interior and exterior historic features of the Corbin Building visible or more visible to the public and as a result make the Corbin Building more attractive. Because the Corbin Building is part of a historic district, this not only benefits the Corbin Building itself, but also the John Street-Maiden Lane Historic District. The rehabilitation of the Corbin Building under Alternative 10 therefore, would create a more attractive environment than under Alternative 9.

3.6.2 COMPARATIVE EVALUATION OF ALTERNATIVES WITH REGARD TO POTENTIAL ENVIRONMENTAL IMPACTS

As described in Section 3.5, Alternatives 9 and 10 are similar in many respects. Their differences are directly related to the way each alternative engages the Corbin Building. Consequently, their differences in potential environmental impacts are also directly related to this feature. The two Build alternatives differ in their impacts on issues related to transit and pedestrians, social and economic conditions, displacement and relocation and cultural resources. The No Action Alternative would have a greater long term impact or a less positive long term impact than Alternatives 9 or the Preferred Alternative for all resources concerned, with the exception of construction impacts, displacement and relocation. A comparative overview of the impact differences between Alternatives 9 and the Preferred Alternative is presented below, with regard to construction impacts, transit and pedestrian impacts, displacement and relocation impacts and impacts on cultural resources.

CONSTRUCTION IMPACTS

Differences between Alternative 9 and the Preferred Alternative in construction impacts relate to the different treatment of the Corbin Building. Both alternatives would require underpinning of the Corbin Building. However, in the Preferred Alternative, the Corbin Building would be modified for adaptive reuse, requiring that all occupants be vacated. Alternative 9 would only require underpinning and would not require the building occupants to vacate the premises. Construction impacts under both Alternative 9 and the Preferred Alternative would be short-term and temporary, however, and would not result in a substantially different impact between the two alternatives. The No Action Alternative would not involve construction and therefore none of the impacts associated with construction.

IMPACTS ON TRANSIT AND PEDESTRIANS

As described in detail in Chapter 6B, the Preferred Alternative would have a greater positive impact on transit and pedestrian movement than Alternative 9, due to the more direct connection from the Dey Street Passageway into the Entry Facility under the Preferred Alternative and pedestrian access to the Entry Facility from three (3) sides, including John Street via the Corbin Building. Pedestrian street level circulation would be better under the Preferred Alternative, as the pedestrian crossing of Broadway at Dey

Street would be less congested. Under Alternative 9, passage through the Corbin Building would not occur and pedestrians would need to either access the Dey Street Passageway west of Broadway or walk around the northeast corner of Broadway and John Street. This would result in higher pedestrian volumes at these locations in Alternative 9 compared to the Preferred Alternative. Alternative 9 would thus result in a less beneficial impact on at these locations than the Preferred Alternative. In addition the Preferred Alternative would also result in a greater improvement to qualitative aspects of transit such as wayfinding and orientation. Transit would be better in the Preferred Alternative due to the greater flexibility for pedestrian flows and greater amount of circulation space within the Entry Facility.

IMPACTS RELATED TO DISPLACEMENT AND RELOCATION

Operation of the Preferred Alternative would involve adaptive reuse of the Corbin Building, which would result in the displacement of existing businesses in that building. Such displacement would not be necessary under Alternative 9. Thus, the Preferred Alternative would have a greater initial displacement impact. The displacement impacts associated with the Corbin Building's adaptive reuse can be mitigated, however by the provisions of the Federal Uniform Relocation Assistance and Real Property Acquisition policies Act and the New York State Eminent Domain Procedure Law. Compensation and relocation assistance would be provided for all occupants displaced.

IMPACTS ON CULTURAL RESOURCES

The Preferred Alternative would have greater long-term benefits to the Corbin Building and the John Street - Maiden Lane Historic District than Alternative 9. Alternative 9 would leave the Corbin Building essentially in its current state, including past modifications to the facade and other parts of the building that are inconsistent with its historic character. Under the Preferred Alternative, the Corbin Building would be acquired by MTA to be integrated with the Entry Facility. In doing so, MTA would rehabilitate the building in coordination with the SHPO and in accordance with the provisions of the Memorandum Of Agreement between the FTA, MTA and SHPO and consulting parties. Under the Preferred Alternative, the Corbin Building will thus benefit from the long-term public ownership. Under the Preferred Alternative both the exterior and interior of the rehabilitated Corbin Building will be visible to the public as the Corbin Building will serve as a gateway into the Entry Facility. Additionally, the beneficial effects on the historic Corbin Building would also indirectly benefit the John Street -Maiden lane Historic District, of which the Corbin Building is a contributing element. The Preferred Alternative via the subway entrances at the Corbin Building, will also provide more direct access to the John Street Maiden Lane Historic District via the new entrances in the Corbin Building at John Street.

3.6.3 PUBLIC COMMENTS ON THE ALTERNATIVES PRESENTED IN THE DEIS

Following the publication of the DEIS, the public environmental review process and interagency coordination generated comments relevant to the selection of alternatives. A total of 58 commentators expressed a preference for a specific alternative analyzed in the DEIS. Of those, 11 indicated a preference for the No Action Alternative. Of the 47 commentators who expressed a preference for a Build Alternative, a total of 11 expressed support specifically for Alternative 10. No support was expressed specifically for Alternative 9; the remaining 36 supporters of a Build Alternative indicated no preference between Alternative 9 or 10.

3.6.4 IDENTIFICATION OF THE PREFERRED ALTERNATIVE

In consideration of the comments received and interagency coordination, including input from the New York State Historic Preservation Office (SHPO) and NYC Landmarks Preservation Commission (LPC), Alternative 10 displayed clear ability to meet the Purpose and Need (as described above). Alternative 10 was selected as the preferred alternative (hereafter referred to as the Preferred Alternative), giving consideration to environmental, economic, technical and other factors, as described above and as documented in more detail this FEIS. To allow a greater understanding of potential environmental

impacts and the basis for selecting Alternative 10 as the Preferred Alternative, the FEIS analysis continues to include Alternative 9 and the No Action Alternative in addition to the Preferred Alternative.★

This Page Intentionally Left Blank