UNIT 10 THERMOGRAVIMETRIC ANALYSIS

Structure

- 10.1 Introduction
 - Objectives
- 10.2 Instrumentation
- 10.3 Sources of Error in TGA
- 10.4 Interpretation of TG Curve
- 10.5 Factors Affecting TG Curve
- 10.6 Applications of Thermogravimetric Analysis
- 10.7 Summary
- 10.8 Terminal Questions
- 10.9 Answers
- 10.10 Further Reading

10.1 INTRODUCTION

Thermogravimetric analysis (TGA) is the most widely used thermal method. It is based on the measurement of mass loss of material as a function of temperature. In thermogravimetry a continuous graph of mass change against temperature is obtained when a substance is heated at a uniform rate or kept at constant temperature. A plot of mass change versus temperature (T) is referred to as the thermogravimetric curve (TG curve). For the TG curve, we generally plot mass (m) decreasing downwards on the y axis (ordinate), and temperature (T) increasing to the right on the x axis (abscissa) as illustrated in Fig. 10.1. Sometime we may plot time (t) in place of T . TG curve helps in revealing the extent of purity of analytical samples and in determining the mode of their transformations within specified range of temperature.

In thermogravimetry, the term ‘decomposition temperature’ is a complete misnomer. In a TG curve of a single stage decomposition, there are two characteristic temperatures; the initial T_i and the final temperature T_f (see Fig. 10.1). T_i is defined as the lowest temperature at which the onset of a mass change can be detected by thermo balance operating under particular conditions and T_f as the final temperature at which the particular decomposition appear to be complete. Although T_i has no fundamental significance, it can still be a useful characteristic of a TG curve and the term **procedural decomposition temperature** has been suggested. The difference $T_f - T_i$ is termed as reaction interval. In a dynamic thermogravimetry a sample is subjected to continuous increase in temperature usually linear with time whereas in isothermal or static thermogravimetry the sample is maintained at a constant temperature for a period of time during which any change in mass is noted. Now we will take up the instrumentation commonly used to obtain TG Curve.

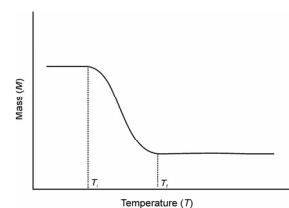

Fig. 10.1: A Typical TG Curve

Objectives

After studying this unit, you should be able to:

- explain the principle of TGA,
- describe the experimental setup of TGA,
- interpret the analytical information from TGA curves, and
- describe the applications of TGA in qualitative and quantitative analysis of inorganic, organic and polymer material.

10.2 INSTRUMENTATION

The instrument used in thermogravimetry (TG) is called a **thermobalance**. It consists of several basic components in order to provide the flexibility necessary for the production of useful analytical data in the form of TGA Curve as shown in Fig. 10.4.

Basic components of a typical thermobalance are listed below:

- i) Balance
- ii) Furnace: heating device
- iii) Unit for temperature measurement and control (Programmer)
- iv) Recorder: automatic recording unit for the mass and temperature changes

These components may be represented by simple block diagram as in Fig. 10.2

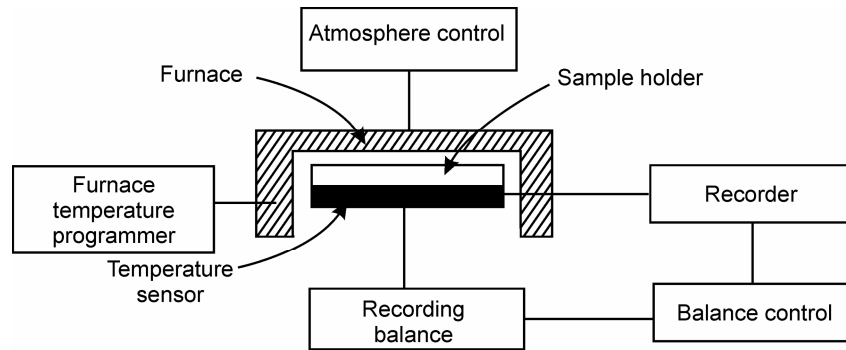

Fig. 10.2: Block diagram of a Thermobalance

Balance

The basic requirement of an automatic recording balance includes accuracy, sensitivity, reproducibility, and capacity. Recording balances are of two types, null point and deflection type. The **null type balance**, which is more widely used, incorporates a sensing element which detects a deviation of the balance beam from its null position. A sensor detects the deviation and triggers the restoring force to bring the balance beam back to the null position. The restoring force is directly proportional to the mass change. **Deflection balance** of the beam type involve the conversion of the balance beam deflection about the fulcrum into a suitable mass – change trace by (a) photographic recording i.e change in path of a reflected beam of light available of photographic recording, (b) recording electrical signals generated by an appropriate displacement measurement transducer, and (c) using an electro-chemical device. The different balances used in TG instruments are having measuring range from 0.0001 mg to 1 g depending on sample containers used.

Furnace

The furnace and control system must be designed to produce linear heating at over the whole working temperature range of the furnace and provision must be made to maintain any fixed temperature. A wide temperature range generally -150 °C to 2000 °C of furnaces is used in different instruments manufacturers depending on the models. The range of furnace basically depends on the types of heating elements are used.

Temperature Measurement and Control

Temperature measurement are commonly done using thermocouples , chromal – alumel thermocouple are often used for temperature up to 1100 °C whereas

Pt/(Pt-10% Rh) is employed for temperature up to 1750 °C. Temperature may be controlled or varied using a program controller with two thermocouple arrangement, the signal from one actuates the control system whilst the second thermocouple is used to record the temperature.

Recorder

Graphic recorders are preferred to meter type recorders. X-Y recorders are commonly used as they plot weight directly against temperature. The present instrument facilitate microprocessor controlled operation and digital data acquisition and processing using personal computer with different types recorder and plotter for better presentation of data.

In Fig. 10.3, we have shown a schematic diagram of the specific balance and furnace assembly as a whole to better understand the working of a thermobalance. In this diagram you can clearly see that the whole of the balance system is housed in a glass to protect it from dust and provide inert atmosphere. There is a control mechanism to regulate the flow of inert gas to provide inert atmosphere and water to cool the furnace. The temperature sensor of furnace is linked to the programme to control heating rates, etc. The balance output and thermocouple signal may be fed to recorder to record the TG Curve.

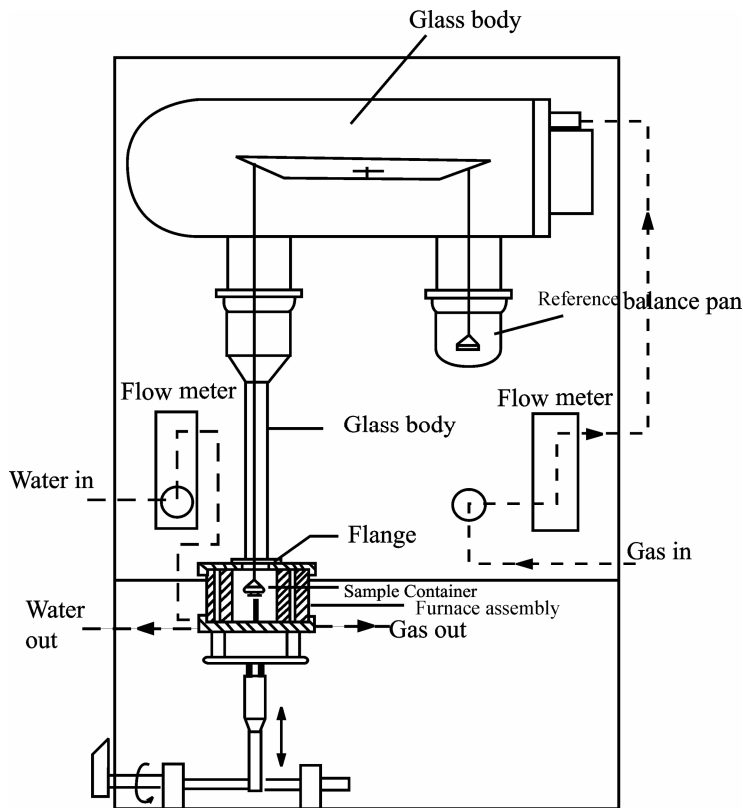

Fig. 10.3: Schematic diagram of a typical balance and furnace assembly

Thermogravimetric Curves

So far we have discussed the instauration of TG now we turn our attention to quantitative aspects of TG. As discussed earlier TG curves represent the variation in the mass (*m*) of the sample with the temperature (*T*) or time (*t*). Normally, we plot mass loss downward on the ordinate (*y*) axis and mass gain upwards as shown in Fig. 10.4.

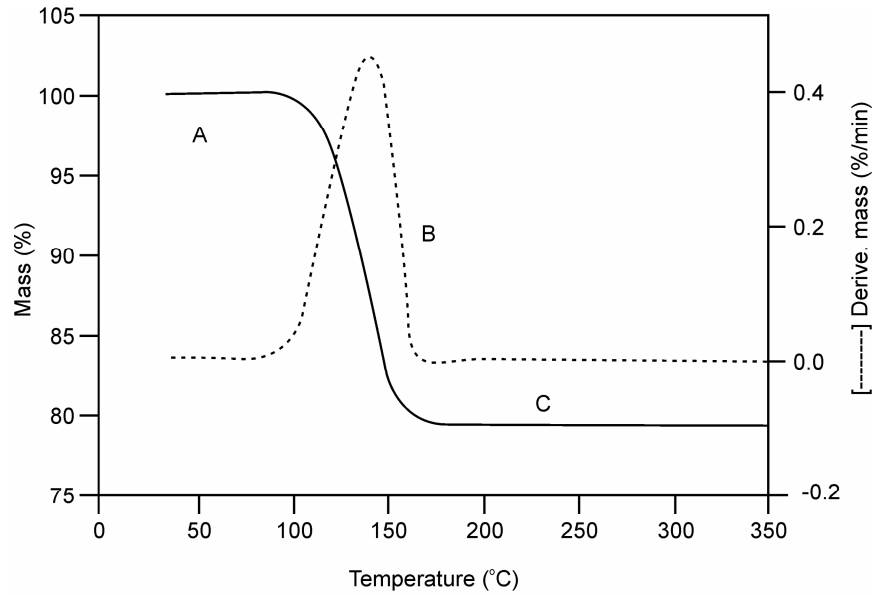

Fig. 10.4: TG Curve. Note the plateau of constant weight (region A), the mass loss portion (region B), and another plateau of constant mass (region C)

Sometime we also record derivative thermogravimetric (DTG) Curves. A DTG curve presents the rate of mass change (dm/dt) as a function of temperature, or time (t) against T on the abscissa (x axis) as shown in Fig. 10.4 when substance is heated at uniform rate. In this figure, the derivatives of the Curve is shown by dotted lines.

SAQ 1

List the different components of a thermobalance.

.....

.....

.....

.....

10.3 SOURCES OF ERRORS IN TGA

There are a number of sources of error in TGA, and they can lead to inaccuracies in the recorded temperature and mass data. Some of the errors may be corrected by placing the thermobalance at proper place and handling it with great care. For understanding we are discussing some common source of errors during operation of a thermobalance.

- i) **Buoyance effect:** If a thermally inert crucible is heated when empty there is usually an apparent weight change as temperature increases. This is due to effect of change in buoyancy of the gas in the sample environment with the temperature, the increase convection and possible effect of heat from the furnace in the balance itself. Now, in most modern thermobalances, this effect is negligible. However, if necessary, a blank run with empty crucible can be performed over the appropriate temperature range. The resultant record can be used as a correction curve for subsequent experiment performed in the same condition.
- ii) **Condensation on balance suspension:** Condensation of the sample will also affect the mass of the sample and consequently the shape of TG curve .This can

be avoided by maintaining a dynamic atmosphere around the sample in the furnace so that all the condensable product may be driven by the flowing gases.

- iii) Random fluctuation of balance mechanism
- iv) Reaction between sample and container
- v) Convection effect from furnace
- vi) Turbulence effect from gas flow
- vii) Induction effect from furnace

Errors of type (iii) can be avoided by proper placing of balance in the laboratory and error (v) can be avoided by sensible choice of sample container. Last three errors (v-vii) have to be considered in the design of the furnace, the balance and its suspension system. By avoiding excessive heating rate and proper gas flow rate some of above mentioned errors may be avoided.

In the light of above discussion it is necessary to calibrate thermobalance before to use.

Calibration of thermobalance for the measurement of mass. It can be done by adding known mass of the sample container and noting the reading of the chart. Temperature calibration: ferromagnetic standards are used for this purpose. In a magnetic field there substances shown detectable mass changes. The ferromagnetic standards are quite suitable for the temperature range from 242 to 771° C.

SAQ 2

What are common source of errors in thermogravimetric analysis?

.....

10.4 INTERPRETATION OF TG CURVES

TG curves of a pure compound are characteristic of that compound. Using TG curve we can relate the mass changes to the stoichiometry involved. This can often lead us directly to the quantitative analysis of samples whose quantitative composition is known. To further illustrate, let's consider the example of TGA curve of CaCO₃, (Fig. 10.5.) This curve indicates that CaCO₃ decomposes in a single step between 800° C and 950° C to form stable oxide CaO and the gas carbon dioxide. This can be explained the chemistry of CaCO₃ when it is heated

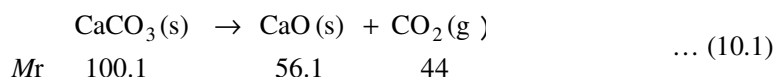

Now again consider the Fig. 10.5 (c), it indicates the % mass lost by the sample is 44 (100.1-56.1) between 800 and 950° C. This exactly corresponds to the mass changes calculations based on stoichiometry of the decomposition of CaCO₃ expressed by the chemical Eq. (10.1). As in this case, percentage weight loss of CaCO₃ will be

$$\begin{aligned}
 m \quad \% &= \frac{M_r(\text{CO}_2)}{M_r(\text{CaCO}_3)} \times 100 && \dots (10.2) \\
 &= \frac{44 \times 100}{100.1} = 44
 \end{aligned}$$

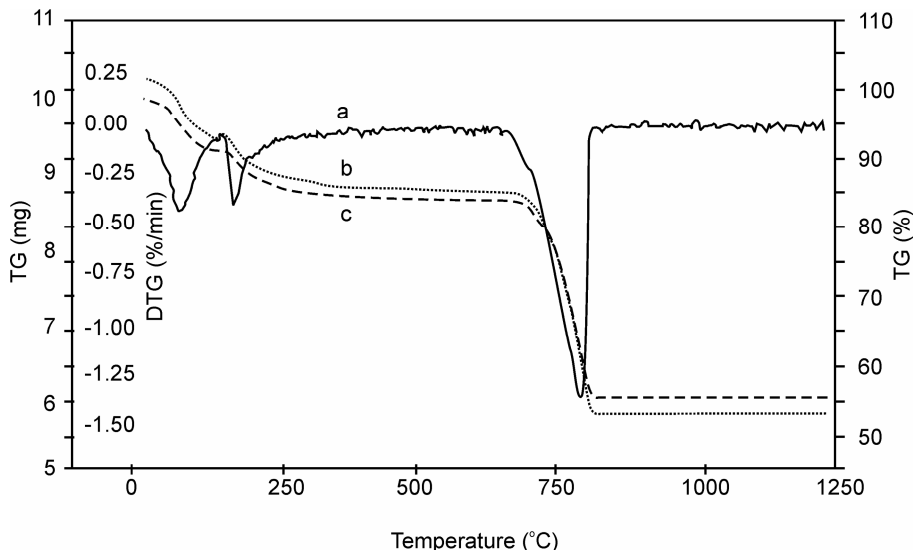

Fig. 10.5: TG and DTG Curve of CaCO₃ at various heating rates (b =10 °C, c = 3 °C) (DTG = Rate of Change of mass, dm/dt) curve

We have seen above how TG Curves is related to stoichiometry (quantitative interpretation). Now we see in next example how it can be used to compare thermal stability of materials (qualitative interpretation). Such information can be used to select material for certain end-use application, predict product performance and improve product quality. Fig. 10.6 gives TG Curves of some polymers. TG Curves clearly indicate that polymer (PVC) is the least thermally stable and polymer (PS) is most thermally stable. Polymer (PS) loses no weight at all below about 500°C and then decomposes abruptly by about 600°C. The other three polymers have all decomposed by about 450°C. Polymers (PMMA) decomposes more slowly overall than the others as indicated by slopes of TG curves. TG curve of polymer (PMMA) has less slope than the others.

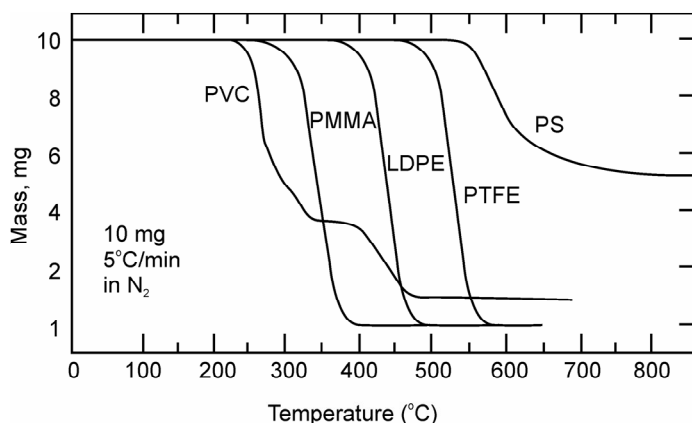
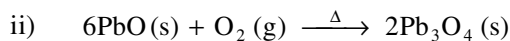
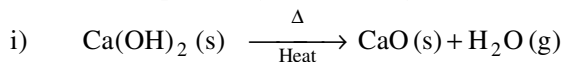
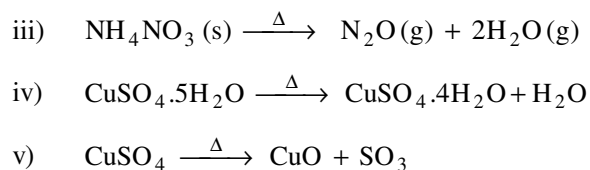

Fig. 10.6: TG Curves of some polymers: PVC = polyvinyl chloride; PMMA = polymethyl methacrylate, LDPE = low density poly ethylene; PTFE = polytetra fluoroethylene; and PS = polystyrene.

SAQ 3

Calculate the percentage mass change (*m %*) for the following reactions.





.....

SAQ 4

A thermogram of a magnesium compound shows a loss of 91.0 mg from a total of 175.0 mg used for analyte. Identify the compound either as MgO, MgCO₃, or MgC₂O₄.

.....

10.5 FACTORS AFFECTING TG CURVE

In the beginning of this units we talked about the lowest temperature, T_i at which the onset of a mass change can be detected by the thermobalance operating under particular conditions and T_f is the final temperature at which the decomposition completed. We may like to call this as decomposition temperature, which is not correct. Actually in TGA experiments, both T_i and T_f do not have fundamental significance, but they can still be a useful characteristic of a TG curve and the termed **procedural decomposition temperature**. It is often used for the temperature at which mass change appears to commence. This indicates us that procedural decomposition temperature does not have a fixed value, but depends on the experimental procedure employed to get it. Similar to this there are many factors which influence a TGA curve. These factors may be due to instrumentation or nature of sample. We have listed the main factors which affects the shape, precision and accuracy of the experimental results in thermogravimetry.

1. Instrumental factors:
 - i) Furnace heating rate.
 - ii) Recording or chart speed
 - iii) Furnace atmosphere
 - iv) Geometry of Sample holder/ location of sensors
 - v) Sensitivity of recording mechanism.
 - vi) Composition of sample container.

2. Sample Characteristics:
 - a) Amount of sample
 - b) Solubility of evolved gases in sample.
 - c) Particle size
 - d) Heat of reaction
 - e) Sample packing
 - f) Nature of sample
 - g) Thermal conductivity.

Now we will take up some important factors in some detail.

a) **Furnace heating rate**

At a given temperature, the degree of decomposition is greater the slower the heating rate, and thus it follows that the shape of the TG curve can be influenced by the heating rate. For a single stage endothermic reaction it has been found that:

- i) $(T_i)_F > (T_i)_S$
- ii) $(T_f)_F > (T_f)_S$
- iii) $(T_f - T_i)_F > (T_f - T_i)_S$

where subscripts F and S indicate fast and slow heating rate respectively. For example, calcium carbonate would not show any mass loss below 600 °C, when heated in a thermobalance at heating rate of 3 °C per min., and yet it is known that CO₂ is evolved at 250 °C. Similarly, polystyrene decomposes 10% by mass when heating rate is 1 °C per min by 357 °C and 10% by mass when heating rate is 5 °C per min by 394 °C. More specifically, it is observed that the procedural decomposition temperature T_i , and also T_f (the procedural final temperature) will decrease with decrease in heating rate and the TG curve will be shifted to the left. This effect is illustrated in Fig. 10.5. The appearance of an inflection in a TG curve at a fast heating rate may well be resolved into a plateau at a slower heating rate. Therefore, in TGA there is neither optimum no standard heating rate, but a heating rate of 3 °C per min. gives a TG curve with maximum meaningful resolution.

b) **Recording or Chart Speed**

The chart speed on the recording of the TG curve of rapid or slow reaction has pronounced effect on the shape of the TG curves. For a slow decomposition reaction low chart speed is recommended for recording the TG curve because at high chart speed the curve will be flattened and it will not show the sharp decomposition temperature. For a slow reaction followed by a rapid one at the lower chart speed the curve will show less separation in the two steps than the higher chart speed curve. For fast-fast reaction followed by slower one similar observation was observed in shorter curve plateaus.

c) **Furnace Atmosphere**

The effect of atmosphere on the TG curve depends on (i) the types of the reaction (ii) the nature of the decomposition products and (iii) type of the atmosphere employed. The effect of the atmosphere on TG curve may be illustrated by taking the example of thermodecomposition of a sample of monohydrates of calcium oxalate in dry O₂ and dry N₂ as shown Fig. 10.7.

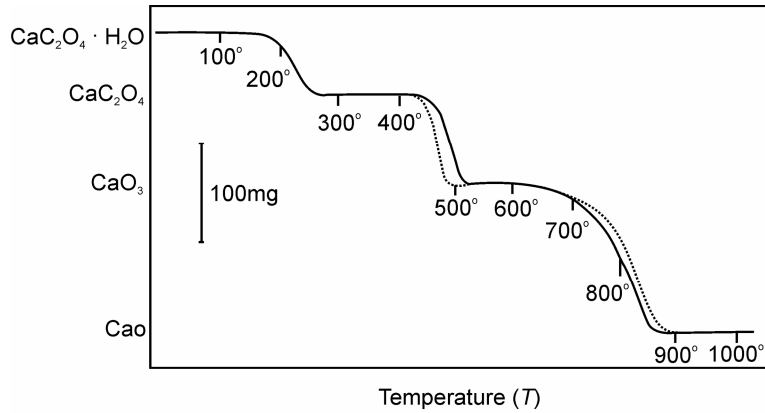
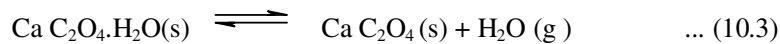

Fig. 10.7: TG Curve of Calcium Oxalate in O₂ and N₂ atmosphere: [———— N₂, - - - - - O₂]

The first step, which is dehydration is reversible reaction.



This is unaffected because both gases are equally effective in sweeping the evolved water vapours away from the sample surface. For the second step,



The curve diverges in O₂ atmosphere because the oxygen reacts with evolved CO, giving a second oxidation reaction which is highly exothermic and so raises the temperature of the un-reacted sample. The temperature accelerates the decomposition of the compound more rapidly and completely at a lower temperature as shown in the above diagram in dry O₂ then in N₂ atmosphere. The third step in decomposition reaction is also reversible reaction.



This step should not be influenced by O₂ or N₂. However there is a slight difference in curves for the two gases as shown in diagram. The small difference was due to the difference in the nature/composition of CaCO₃ formed in the two atmospheres. This is due to the particle size, surface area, lattice defects or due to the other physical characteristics of CaCO₃ formed.

d) **Sample Holder**

The sample holders range from flat plates to deep crucible of various capacities. The shape of the TG curve will vary as the sample will not be heated in identical condition. Generally, it is preconditioning that the thermocouple is placed on near the sample as possible and is not dipped into the sample because it might be spoiled due to sticking of the sample to the thermocouple on heating. So actual sample temperature is not recorded, it is the temperature at some point in the furnace near the sample. Thus it leads to source of error due to the thermal lag and partly due to the finite time taken to cause detectable mass change. If the sensitivity of recording mechanism is not enough to record the mass change of the sample then this will also cause error in recording the weight change of the sample. If the composition of the sample contains is such that it reacts either with the sample, or product formed or the evolved gases then this will cause error in recording the mass change of the sample.

e) **Effect of Sample Mass**

The sample mass affects the TG curve in following

Thermal Methods

- i) The endothermic and exothermic reactions of the sample will cause sample temperature to deviate from a linear temperature change.
- ii) The degree of diffusion of evolved gases through the void space around the solid particles.
- iii) The existence of large thermal gradients throughout the sample particularly, if it has a low thermal conductivity.

Thus, it is preferable to use as small a sample as possible depending on the sensitivity of the balance.

f) Effect of Sample Particle Size

The particle size will cause a change in the diffusion of the evolved gases which will alter the reaction rate and hence the curve shape. The smaller the particle size, greater the extent of decomposition at any given temperature. The use of large crystal may result in apparent vary rapid mass loss during heating. This may be due to the mechanical loss of part of the sample by forcible ejection from the sample container, when the accumulated evolved gases within the coarse grains are suddenly released.

g) Effect of Heat of Reaction

The heat of reaction will affect the extent to which sample temperature proceeds or succeeds the furnace temperature. This depends on whether the reaction is exothermic or endothermic and consequently the extent of decomposition will also be affected.

The other sample characteristics such as sample packing, nature of the sample and its thermal conductivity will also affect the shape of TG curves. If the sample is packed loosely then the evolved gases may diffuse more easily than if the sample packed tightly.

If the sample reacts with the sample container on heating then it will not give the mass of the product formed so the sample will change. We can avoid this effect by a sensible choice of sample container.

SAQ 5

What are the common instrumental factors affecting TG curves.

.....

.....

.....

.....

.....

10.6 APPLICATIONS OF TERMOGRAVIMETRIC ANALYSIS

In the previous section we have seen how TGA can be used to understand the chemistry of decomposition of a particular compound. TGA also provides information about the temperature range over which a particular sample appears to be stable or unstable. We have also interpreted TG curves qualitatively. Beside these there are many other applications of thermogravimetric analysis. Some are listed below:

- i) Purity and thermal stability.

- ii) Solid state reactions.
- iii) Decomposition of inorganic and organic compounds.
- iv) Determining composition of the mixture.
- v) Corrosion of metals in various atmosphere.
- vi) Pyrolysis of coal, petroleum and wood.
- vii) Roasting and calcinations of minerals.
- viii) Reaction kinetics studies.
- ix) Evaluation of gravimetric precipitates.
- x) Oxidative and reductive stability.
- xi) Determining moisture, volatile and ash contents.
- xii) Desolvation, sublimation, vaporizations, sorption, desorption, chemisorptions.

It is not possible to discuss all these applications at this level; it is worth to describe some of the applications which are more common.

1. Analysis of Inorganic and Organic Mixtures

We have already seen that single and pure compound gives characteristic TG curves. Now, we will see how TG Curves can be used in predicting relative quantities of the components of a mixture.

Binary mixtures

Consider a mixture of two compounds AB and CD having characteristic TG Curves which are different from each other as shown in Fig. 10.8

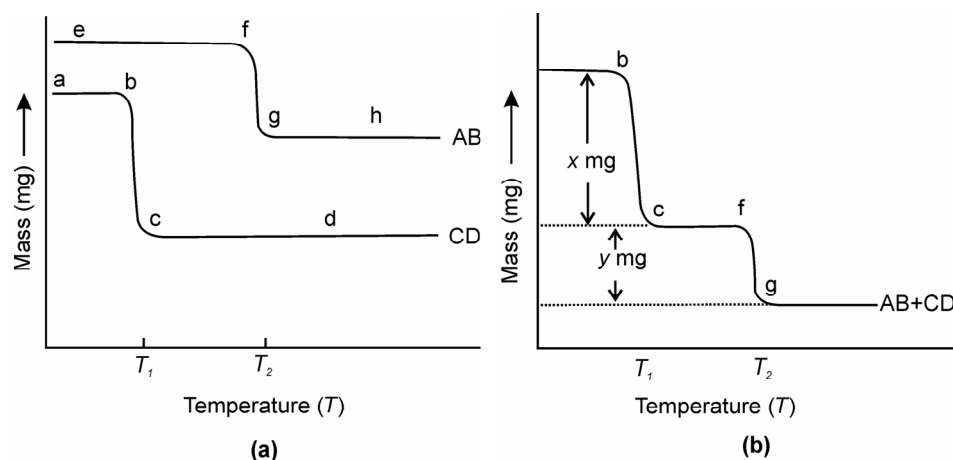
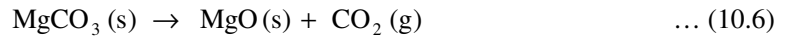

Fig. 10.8: (a) Thermogravimetric curves of two compounds AB and CD and (b) their Mixture

The decomposition of pure compound AB and CD occur at T_1 , and labeled as bc and temperature T_2 , and labeled as fg respectively, as illustrated in Fig. 10.8 (a). The TG curve of mixture of AB and CD together is shown in Fig. 10.8 (b). You can see in this figure, the plateaus (corresponding to the regions of constant mass) commence at about the same temperature as they do in the TG Curves for the pure compounds AB and CD. You can also notice that the mass loss overall up to T_1 is x mg and from T_1 to T_2 it is an additional y mg. By measuring these two quantities x and y from the TG curves of Fig. 10.8 (b), we can determine the relative quantities of AB and CD in the original binary mixture. To understand further consider the mixtures of calcium and magnesium carbonates.

i) **Analysis of a mixture of calcium and magnesium carbonates**

A typical TG curve of a mixture of calcium and magnesium carbonates is shown in Fig. 10.9. You can notice that a significant mass loss occurs before 210° C. This is due to the moisture present in the mixture. Another mass loss at about 480° C is due to the following reaction:



Earlier we mentioned that CaCO₃ decomposes at about 800 °C. In Fig. 10.8 mass loss between about 600 °C and 900 °C can be interpreted due to decomposition of CaCO₃.

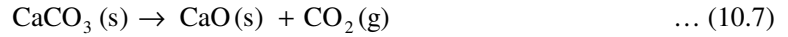

Portion of the curve ab represents a mixture of MgO and CaCO₃ and cd represents a residue of the mixture of MgO and CaO. Both these plateaus ab and cd represent weight *m*₁ and *m*₂, respectively. In fact mass *m*₁ is due to CaCO₃+ MgO.

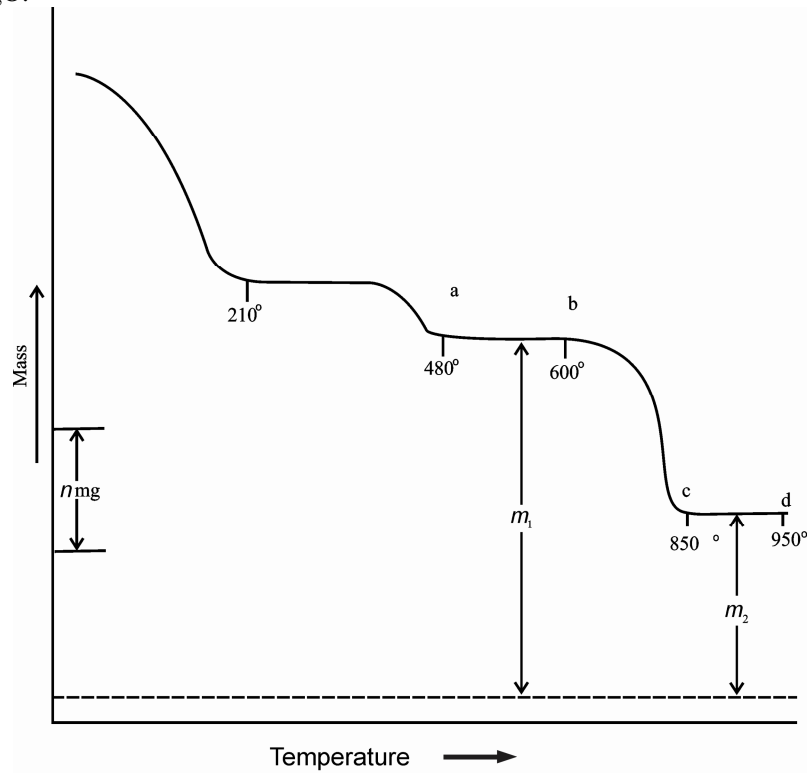

Fig. 10.9: TG curve of mixture of calcium and magnesium carbonate

Thus, *m*₁ – *m*₂ is the loss of CO₂ between 500° C and 900° C due to the decomposition of CaCO₃. Using TGA curve we can relate the mass of different components formed during TGA experiment.

The mass of CaO (*m*₃) formed can be calculated using following Eq. (10.8)

$$m_3 = 1.27 (m_1 - m_2) \quad \dots (10.8)$$

This equation can be obtained as follows:

The CaO is formed by the evolution of CO₂ on the decomposition of CaCO₃,

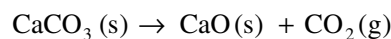

$$M_r \quad 100.1 \quad \quad 56.1 \quad \quad 44$$

From the above equation 1mole of CaCO_3 gives 1 mole of CO_2 and 1 mole of CaO . Thus, moles of CO_2 in the given examples = $\frac{(m_1 - m_2)}{M_r(\text{CO}_2)}$ and this is equal to moles of CaO formed

Thus the amount of CaO must be, $m_3 = \frac{(m_1 - m_2)}{44} \times M_r(\text{CaO})$

where, $M_r(\text{CaO})$ is the relative molar mass of CaO .

$$m_3 = \frac{(m_1 - m_2)}{44} \times 56 \text{g}$$

$$m_3 = 1.27(m_1 - m_2) \text{ g}$$

We know the mass of residue left, i.e., m_2 , the mass of MgO (m_4) can be calculated.

$$m_4 = m_2 - m_3$$

Here m_3 is the mass of CaO formed, which is equal to $1.27 (m_1 - m_2)$. Thus

$$m_4 = m_2 - 1.27 (m_1 - m_2)$$

Mass of the Ca (m_{ca}) in the original sample can also be related to m_1 and m_2 by the following formula

$$m_{\text{ca}} = 0.91 (m_1 - m_2)$$

This can be obtained as follows:

You know amount of Ca in CaCO_3 and CaO will be equal in moles, therefore amount of Ca in

$$m_{\text{Ca}} = m_3 \times \frac{A_r(\text{Ca})}{M_r(\text{CaO})} = 1.27 (m_1 - m_2) \times \frac{A_r(\text{Ca})}{M_r(\text{CaO})}$$

where, $A_r(\text{Ca})$ and $M_r(\text{CaO})$ are the relative atomic mass and relative molar mass of Ca and CaO , respectively. Thus,

$$= 1.27 (m_1 - m_2) \times 40/56 = 0.91 (m_1 - m_2)$$

Similarly, mass of magnesium in the original sample can be related to m_1 and m_2 :

Thus, the mass of Mg in original sample (m_{Mg})

$$= (\text{mass of residue} - \text{mass of CaO}) \times \frac{A_r(\text{Mg})}{M_r(\text{MgO})}$$

$$m_{\text{Mg}} = (m_2 - m_3) \times \frac{A_r(\text{Mg})}{M_r(\text{MgO})} = (m_2 - m_3) \times \frac{24.3}{40.3}$$

$$m_{\text{Mg}} = 0.60 (m_2 - m_3)$$

ii) Mixture of calcium and magnesium oxalates

Calcium oxalate monohydrate is unsatisfactory weighing form for determining calcium as oxalate because its tendency to retain excess moisture even at 110°C , co-precipitated ammonium oxalate remain un-decomposed. The anhydrous calcium oxalate is hygroscopic but CaCO_3 is excellent weighing form if heated to $500 \pm 25^\circ\text{C}$ as can be seen in TG curve of $\text{CaC}_2\text{O}_4 \cdot \text{H}_2\text{O}$. Above 635°C the decomposition of CaCO_3 commences to become significant under usual laboratory conditions and completely converted to CaO at 900°C . Thus, calcium oxalate monohydrate decomposes in three steps, first dehydration,

Thermal Methods

second removal of CO and formation of CaCO_3 then third step CaCO_3 decomposes to CaO (see Fig. 10.10).

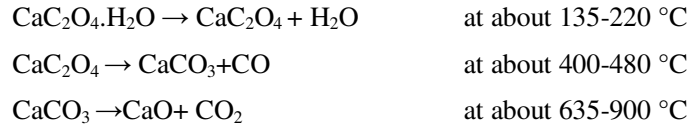

But magnesium oxalate dihydrate decomposes in two steps instead of three steps. First, dehydration then removal of CO and CO_2 simultaneously and forming MgO, there is no horizontal corresponding to MgCO_3 as it is thermally unstable at this temperature.

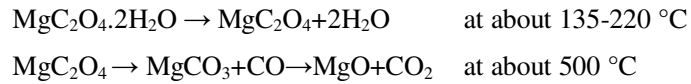

The TG curve for the mixture of $\text{CaC}_2\text{O}_4 \cdot \text{H}_2\text{O}$ and $\text{MgC}_2\text{O}_4 \cdot 2\text{H}_2\text{O}$ shows two mass losses up to $500\text{ }^\circ\text{C}$, first at about $200\text{ }^\circ\text{C}$ due to loss of water and the second mass loss occurs in the $390\text{-}500\text{ }^\circ\text{C}$ range which is due to decomposition of both calcium and magnesium oxalates. Thus, at $500\text{ }^\circ\text{C}$, the composition of the mixture will be CaCO_3 and MgO. Third mass loss after $500\text{ }^\circ\text{C}$ is due to only the decomposition of CaCO_3 . If m_1 and m_2 are the mass of the mixture at $500\text{ }^\circ\text{C}$ and $900\text{ }^\circ\text{C}$ then similar to the previous example we can calculate the amount of calcium and magnesium in the original sample.

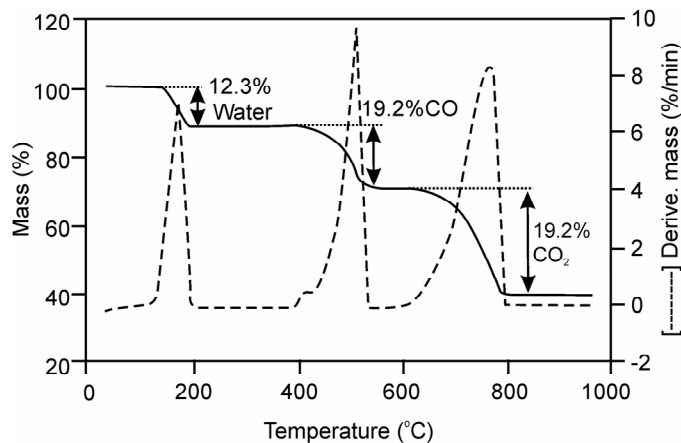
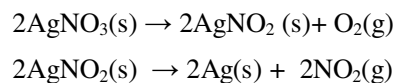

Fig.10.10: DTG/TG curve of calcium oxalate

iii) Analysis of a mixture of AgNO_3 and $\text{Cu}(\text{NO}_3)_2$

The TG curve of pure AgNO_3 , $\text{Cu}(\text{NO}_3)_2$ and their mixture are given in Fig. 10.11. Curve a is the curve of dry crystalline AgNO_3 . A horizontal extends to $340\text{ }^\circ\text{C}$ and is followed by descent as far as $473\text{ }^\circ\text{C}$. At this temperature decomposition sets in abruptly and nitrous fumes are expelled up to $610\text{ }^\circ\text{C}$. After that there is much slower mass loss from $610\text{ }^\circ\text{C}$ to $810\text{ }^\circ\text{C}$.

Decomposition of AgNO_2 , which is not observed when CuO is present, no doubt the latter catalyses the decomposition. Above $810\text{ }^\circ\text{C}$ the weight is again constant due to the formation of pure Ag metal.



While the copper nitrate hexahydrate gives a quite different curve b. Water and nitrogen oxide are driven off up to $150\text{ }^\circ\text{C}$ to $200\text{ }^\circ\text{C}$, then a horizontal indicates the existence of zone of a new compound, which has been analysed and it corresponds to a basic nitrate $\text{Cu}(\text{NO}_3)_2 \cdot 2\text{Cu}(\text{OH})_2$. After that between $200\text{ }^\circ\text{C}$

and 610 °C this compound decomposes vigorously from 250 °C and subsequently more slowly. The residue is CuO which only become constant at 940 °C.

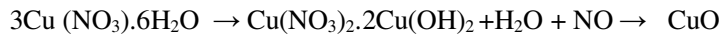

If a mixture of AgNO_3 and $\text{Cu}(\text{NO}_3)_2$ is placed in thermobalance, the curve c is recorded. The horizontal related to the basic copper nitrate is, nevertheless, well marked. From 240 °C to 400 °C there is a residue keeping constant mass ($\text{AgNO}_3 + \text{CuO}$), while above 900 °C a mixture of $\text{Ag} + \text{CuO}$ is present.

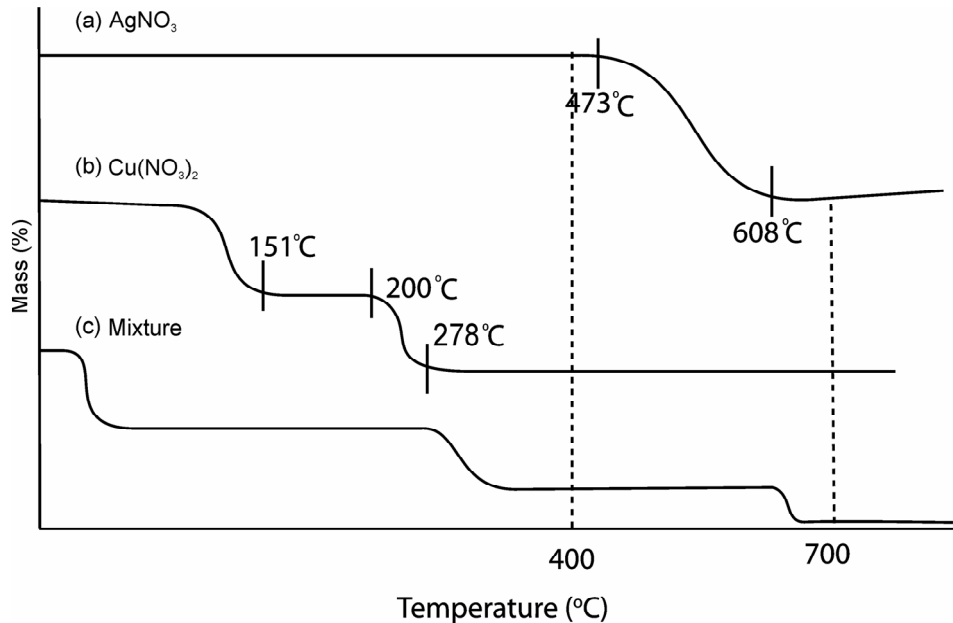

Fig. 10.11: TG curve of nitrates: A: AgNO_3 , B: $\text{Cu}(\text{NO}_3)_2$ and C: $\text{AgNO}_3 + \text{Cu}(\text{NO}_3)_2$ mixture

If m_1 and m_2 are the mass of the sample at 400 °C and 700 °C, respectively, the amount of silver and copper in the sample can be calculated similar to previous example.

A binary alloy of Ag and Cu can be analyzed with $\pm 3\%$ error by this method by dissolving the alloy in HNO_3 and then running thermogram and recording successive weight at 400 °C and 700 °C by solving following simultaneous equations:

$$(170/108)x + (79/63)y = m_1$$

$$x + (79/63)y = m_2$$

where x and y are the masses of Ag and Cu in the alloy, m_1 and m_2 are the masses of the sample at 400 °C and 700 °C, respectively, 170 is the molar mass of AgNO_3 , 1000 is the relative atomic mass of Ag, 79 is molar mass of CuO and 63 is the relative atomic mass of Cu.

Complex mixture

In this category we are considering the analysis of a mixture of calcium, strontium and barium oxalates. In the thermogram of a mixture of Ca, Sr and Ba oxalates it is noticed that in between 100 ° and 250 ° C the water of hydration is evolved from all metal oxalates, after the loss of the water of hydration, the curve exhibited a horizontal weight level from 250-360 °C, which corresponds to the composition for anhydrous metal oxalates. Then all the three oxalates decomposed simultaneously to the carbonates and the process completed at

Thermal Methods

500°C. Then from 500 °C to 620 °C the anhydrous carbonates were stable. On further heating, the CaCO₃ decomposed in the temperature range 620°C- 860 °C to oxide followed by the decomposition of SrCO₃ from 860 °C to 1100°C at which temperature BaCO₃ began to decompose (see Fig. 10.12). From weight loss curve, the following data are obtained.

- I- mass of hydrated oxalates at 100 °C(mass of the sample) = m_s
- II- mass of water of hydration = m_1
- III- mass of CO formed by the decomposition of metal oxalates = m_2
- IV- mass of CO₂ formed by the decomposition of CaCO₃ = m_3
- V- mass of CO₂ formed by the decomposition of SrCO₃ = m_4

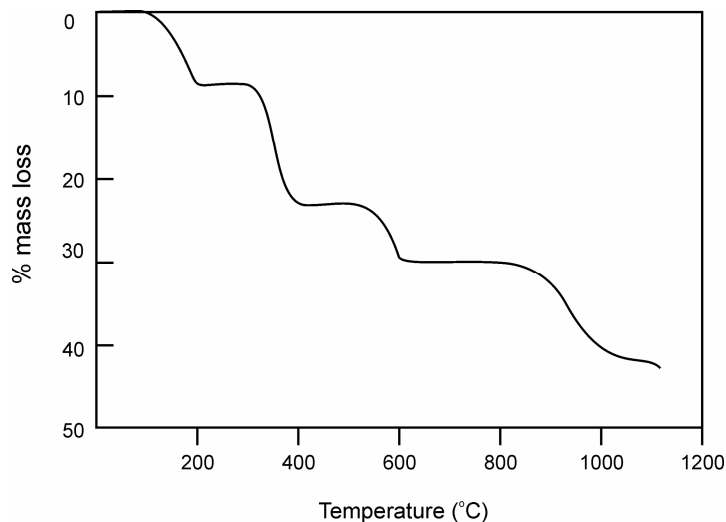

Fig. 10.12: TGA Curve of the mixture of Calcium, Strontium and Barium oxalate

We can calculate the amount of Ca, Ba and Sr as follows:

From the amount of CO₂ (m_4) formed by the decomposition of SrCO₃, we can calculate the mass of SrCO₃. Simultaneously from the mass of CO₂ (m_3) formed by the decomposition of CaCO₃, we can calculate the amount of CaCO₃.

From thermogram we know the total mass of all the carbonates, so by subtracting the amount of carbonates of Ca + Sr, we will get the mass of BaCO₃. From the mass of CaCO₃, SrCO₃ and BaCO₃ we can calculate easily the amount of Ca, Sr and Ba present in the mixture. From the steps discussed above we can arrive on the following formula to calculate the amount of Ca = m_{Ca} , Sr = m_{Sr} , Ba = m_{Ba} .

$$\text{Amount of Ca } (m_{Ca}) = 0.91068 \times m_3$$

$$\text{Amount of Sr } (m_{Sr}) = 1.9911 \times m_4$$

$$\text{Amount of Ba } (m_{Ba}) = m_s - 1.9457 \times m_3 - 2.5788 \times m_4$$

Organic Mixtures

TGA also provides quantitative information on organic compound decompositions and is particularly useful for studying polymers. For example TGA can be used in the determination of the amount of vinyl acetate in copolymers of vinyl acetate and polyethylene. When vinyl acetate is heated it loses acetic acid at about 340 °C. TG curves shown in Fig. 10.13 for several vinyl acetate polyethylene copolymers are clearly indicating the loss of acetic acid at about 340 °C due to the decomposition of

vinyl acetate. Each mole of vinyl acetate loses one mole of acetic acid. The amount of vinyl acetate in the polymers can be calculated.

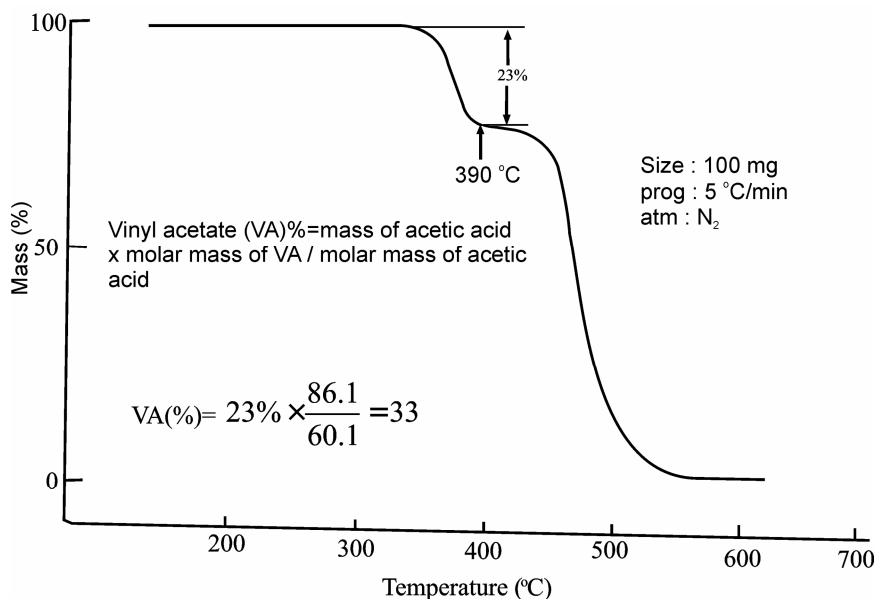
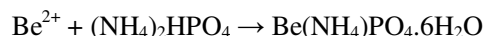

Fig. 10.13: TG curve of vinyl acetate copolymers

2. Gravimetric precipitates should be dried or ignited

Another important application of TG is the determination of correct drying temperature for precipitates used in gravimetry analysis. It also provides information whether a gravimetric precipitates should be dried or ignited. For familiar precipitates ignition temperature is generally based upon practical experience of the chemical properties of the substance, such as AgCl is dried at 130-150 °C and BaSO₄ is heated at 800 °C –900 °C. A better procedure is to make use of TG curves. It is assumed that the horizontal portion of the TG curve gives the range of temperature over which the composition is constant and therefore the mass is also constant and the precipitates can be dried in this temperature range of gravimetric analysis. The precipitate can be dried in this temperature range for gravimetric analysis. It was earlier reported that the precipitate of Al(OH)₃ should be ignited at 1200-1300 °C to get Al₂O₃. But with the help of TG curve we come to know that this precipitate may be ignited at 1030 °C in order to get Al₂O₃. Aluminum oxinate [Al(C₉H₆NO)₃] may be dried at 105- 110 °C as indicated by TG curve. TlAg₂AsO₄ furnishes a horizontal on the recording between 20 to 846 °C. It can, therefore, be weighted after drying or ignition in this range of temperature. On the other hands the precipitate of calcium picolinate, Ca(C₁₀H₇O₅N₄)₂.7H₂O begins to decompose at 300 °C, so it must be dried in a current of dust free air. Beryllium is precipitated as ammonium beryllium phosphate with ammonium hydrogen phosphate in the presence of ammonia.



Its TG curve indicates the distinction in the crystal i.e. the elimination of water and ammonia at 30 °C so that there is no possibility of weighing anhydrous beryllium phosphate. The thermogram shows a continuous loss in weight up to 600 °C, above this temperature the mass remains constant, this mass corresponded to the composition Be₂P₂O₇. Thus, ammonium beryllium phosphate decomposes easily as compared to beryllium hydroxide. Thus, this is the better method for the determination beryllium. Thus, TG curve helps in finding the temperature at which the precipitate should be dried or ignited. If beryllium hydroxide is precipitated by ammonia with BeSO₄, the precipitate is washed and ignited to give BeO.

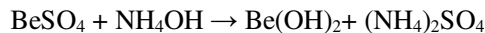

$\text{Be}(\text{OH})_2$ is converted to BeO only at about 900°C . Thus, ammonium beryllium phosphate decomposes easily to $\text{Be}(\text{OH})_2$. Thus, it is better to precipitate beryllium with ammonium hydrogen phosphate and then ignite it to 640°C to BeP_2O_7 . Thus TG curves help in finding the temperature at which the precipitate should be dried or ignited.

3. Analysis of Polymeric Materials:

The thermogravimetric analysis has very versatile application in polymer analysis, the acquired information by TGA is confined to the detection of change in mass of the sample as its temperature or time duration alters. The technique is used to study the decomposition, oxidation reactions and also some physical processes such as vaporization, sublimation and desorption. The main conclusion drawn by TGA are: thermal stability, compositional analysis, life time assessment and degradation kinetics. The TG curve provides information about the decomposition of various polymers, which may be used for identification purposes and also assessment of thermal stability. The basic route by which a polymer degrades can be categorized according to following mechanism:

1. main chain scission
2. side chain scission
3. elimination
4. depolymerisation
5. cyclization
6. cross-linking

Out of the above steps only 1-4 lead to change in mass and can be detected in TGA. Fig. 10.6 is showing thermogravimetric analysis of Polyvinyl Chloride (PVC), High Density Polyethylene (HDPE), Poly Methyl Methacrylate (PMMA), Polytetrafluoroethylen (PTFE) and Polystyrene (PS). The polymer starts degradation at the extrapolated on set of the lowest temperature mass loss or quote the temperature at which 5% mass loss has taken place. The PVC starts degradation at lower temperature $\sim 150^\circ\text{C}$ and takes place in two steps while NYLON -6, LDPE and PTFE start degrading at higher temperatures 400°C , 450°C and 550°C respectively and in single steps. Qualitatively, the higher the decomposition temperature, the more positive is the ΔG value at room temperature and the greater the stability. This can predict the relative stability of the polymers.

The thermogram shown in Fig. 10.13 gives information about the relative composition of constituents in analyzed poly (ethylene-co-vinyl acetate) copolymers. The vinyl acetate component shows a characteristics mass-loss associated with elimination of acetic acid before the main chain degradation occurs. In this case TG can be used as quantitative means of estimating copolymer composition.

4. Reaction Kinetics

In addition to the application discussed above, TGA has also been used to elucidate the kinetics of decomposition reactions. This involves analyzing the shape of the TG curve. In general the rate of reaction at any measured temperature is proportional to the slope of the curve, but a number of uncertainties sometimes make these analyses of questionable value. Even though lot of work has be reported on the subject. Here we are giving a brief discussion on the scope of kinetic analysis by TGA method.

The both isothermal and dynamic methods are in use for kinetic studies but the isothermal measurement at elevated temperature and measure the time taken for a certain extent of mass loss to occur is simpler.

The temperature dependence of chemical processes may be expressed by the Arrhenius equation.

$$K = A \exp(-E_a/RT) \quad \dots (10.9)$$

where K is the rate constant, R the gas constant and T the thermodynamic (Kelvin) temperature. The values of the Arrhenius parameter (E_a and A) provide measures of the magnitude of the energy barrier to reaction (the activation energy, E_a) and the frequency of the occurrence of a condition that may lead to reaction (the frequency factor A , s^{-1}). The rate constant K is defined by the relationship between the rate of reaction ($d\alpha/dt$) and the extent of conversion or fraction reacted decomposed (α). The general relation to describe the relationship between ($d\alpha/dt$) and (α) is

$$(d\alpha/dt) = k\alpha^m (1-\alpha)^n \quad \dots (10.10)$$

Therefore, from Eq. (10.10) it is possible to derive various sub class of rate equation such as first order decay, nucleation, growth, etc. by changing the values of m and n . Isothermal experiments provide the means of determining the form of kinetic equation through discrimination between different models is not straight forward. A simpler approach is to substitute the reciprocal of the isothermal life time for the rate constant in Eq. (10.9) and extrapolate the data to the region of interest.

Isothermal measurement suffers from the drawback of being rather time consuming. There are also difficulties in bringing the sample and apparatus to the required temperature without some decomposition of the sample having already taken place. One way of avoiding this problem is to change a rate controlling variable during the course of measurement. A useful method is temperature jump TGA. The rate of decomposition can then be measured either side of the change in temperature and the activation energy determined from Eq.(10.11).

$$E_a = R \ln [(dm/dt)_{T_1} / (dm/dt)_{T_2}] [1/T_1 - 1/T_2] \quad \dots (10.11)$$

where $(dm/dt)_{T_1}$ and $(dm/dt)_{T_2}$ are the rate of mass loss at T_1 and T_2 either side of temperature jump. The study of kinetics using data from conventional rising temperature TGA have been proposed by many scientists but the most popular method is described by Ozawa and Flynn and Wall, which has been incorporated into an American Society of Testing Materials standard methods. In this method, essentially separate measurements are carried out at different linear heating rate and temperature at which a set of percentage mass loss occurs. These are then plotted as function of heating rate (dT/dt) and the activation energy determined by an iterative process. We often assume, without appropriate justification, that decomposition reaction are first order processes as in Eq. 10.12.

$$(d\alpha/dt) = k(1-\alpha) \quad \dots (10.12)$$

Thus, it is possible to predict the life time for say 10% mass loss as a function of temperature. The advance method for studying degradation kinetics is known as modulated temperature TG. This uses a temperature profile in which a sinusoidal temperature fluctuates upon conventional linear rising temperature. The curves showing the heating rate (dT/dt) and rate of mass loss ($-m/dt$) make the effect of the temperature modulation apparent. E_a for the chemical decomposition is the calculated according to Eq. 10.13.

$$E_a = R [T_{av}^2 - (0.5 T_{amp})^2] L / T_{amp} \quad \dots (10.13)$$

where T_{av} is the average thermodynamic temperature, T_{amp} is the amplitude of the temperature modulation and L is the logarithm of the amplitude of the rate of mass loss over one modulation. Plots of mass and E_a as a function of temperature. The mt -TG is a relatively new technique which promises to simplify the acquisition of

kinetic data. The some general kinetic models used in TGA studies are tabulated in Table 10.2. The main difficulty in studying kinetic analysis using TGA is deciding which of such a large number for equation. proposed for the model is being observed. This is further compounded because several equations may give very similar curves and thus appear to give equally good to some experimental data.

Table-10.2: Important Rate Equations used in Kinetic Analysis

S.N	Name	Notion	Integral equation $g(x) = kt$	Differential equation $d\alpha/dt = kf(\alpha)$
Diffusion controlled				
1.	One-dimensional	D1	$kt = \frac{1}{2} \alpha^2 k$	$d\alpha/dt = k\alpha^1$
2.	Two dimensional	D2	$kt = (1-\alpha) \ln (1-\alpha) + \alpha$	$d\alpha/dt = -k/\ln(1-\alpha)$
3.	Jander (three dimensional)	D3	$kt = \frac{3}{2} \left[1 - (1-\alpha)^{1/3} \right]^2$	$d\alpha / dt = k(1-\alpha)^{2/3} \left[1 - (1-\alpha)^{1/3} \right]^{-1}$
4.	Ginsting-Brounshtein	D4	$kt = \frac{3}{2} \left[1 - (2\alpha/3) \right] - (1-\alpha)^{2/3}$	$d\alpha / dt = k \left[(1-\alpha)^{1/3} - 1 \right]$
Sigmoidal α -time curve				
5.	Avrami-Erofeev	A2	$kt = 2[-\ln (1-\alpha)]^{1/2}$	$d\alpha/dt = k(1-\alpha) [-\ln (1-\alpha)]^{1/2}$
6.	Avrami-Erofeev	A3	$kt = 3[-\ln (1-\alpha)]^{1/3}$	$d\alpha/dt = k(1-\alpha) [-\ln (1-\alpha)]^{1/3}$
7.	Avrami-Erofeev	A4	$kt = \frac{4}{3} [-\ln (1-\alpha)]^{3/4}$	$d\alpha/dt = (1-\alpha) [-\ln (1-\alpha)]^{1/4}$
8.	Prout - Tompkins	B1	$kt = \ln [\alpha/(1-\alpha)]$	$d\alpha/dt = k\alpha(1-\alpha)$
Order with respect to α				
9.	Zero order	F0	$kt = \alpha$	$d\alpha/dt = kc$
10.	first order	F1	$kt = -\ln(1-\alpha)$	$d\alpha/dt = k(1-\alpha)$
11.	Second order	F2	$kt = (1-\alpha)^{-1} - 1$	$d\alpha/dt = k(1-\alpha)^2$
Geometric models				
12.	Interface (Contracting Area)	R2	$kt = 2[1-(1-\alpha)^{1/2}]$	$d\alpha/dt = k(1-\alpha)^{1/2}$
13.	Interface (Contracting Volume)	R3	$kt = 3[1-(1-\alpha)^{1/3}]$	$d\alpha/dt = k(1-\alpha)^{2/3}$
14.	Interface	R4	$kt = \frac{3}{2} [1 - (1-\alpha)^{2/3}] kt$	$d\alpha/dt = k(1-\alpha)^{1/3}$
Power law				
15.	Power law (half poser)	P1 (n=2)	$kt = 2\alpha^{1/2}$	$d\alpha/dt = k\alpha^{1/2}$
16.	Power law (third poser)	P2 (n=3)	$kt = 3\alpha^{1/3}$	$d\alpha/dt = k\alpha^{2/3}$
17.	Power law (quarter power)	P3 (n=4)	$kt = 4\alpha^{1/4}$	$d\alpha/dt = k\alpha^{3/4}$

where α is the fraction reacted, t is time, k is the rate constant, $f(\alpha)$ is the particular kinetic function and $g(\alpha)$ is the algebraical integral of $1/f(\alpha)$.

SAQ 6

A mixture of CaO and CaCO₃ is analysed by TGA. The result indicates that mass of the sample decreases from 250.6 mg to 190.8 mg only between 600°C and 900°C. Calculate the percentage of calcium carbonate in the mixture.

.....
.....
.....
.....
.....

10.7 SUMMARY

Thermogravimetric Analysis (TGA) technique has been described for its basic principle, instrumentation and applications. The interpretation of results and applications are discussed by taking different examples. The elementary calculation are included to elaborate the topics. The probable cause of errors, their remedies, interpretation of result are also discussed.

10.8 TERMINAL QUESTIONS

1. Formulate the solid state reaction of sodium bicarbonate when heated. It decomposes between 100 and 225 °C with evolution of water and carbon dioxide. The combined loss of water and carbon dioxide totaled 36.6% by mass whereas the mass loss due to carbon dioxide alone was found to be 25.4 %.
2. Thermogravimetric studies of carbon black filled rubber sample is performed in inert atmosphere upto 950 °C and then quickly changing the atmosphere to air. The observed weight loss is ~ 66.41% upto 500 °C and the mass becomes constant and further the mass loss between 1300 °C to 2800 °C . Predict the composition of rubber.
3. The TGA and DTA data Manganese Phosphate Monohydrate are shown in Table:

TGA	150 °C (- H ₂ O)	360°C (- PH ₃)	800°C (- H ₂ O)	Nil		Nil
DTA	160 °C (endo)	375 °C (exo)	850 °C (endo)	590 °C (exo)	900°C (exo)	1180 °C (exo)

Explain the probable transition of unidentified peaks in TGA.

4. What types of standard are required to calibrate the mass variation obtained with a TGA equipment?
5. What type of standards are required for temperature calibration of any TGA.
6. A mixture of CaCO₃ and CaO is analysed using TGA technique. TG curve of the sample indicates that there is a mass change from 145.3 mg to 115.4 mg between 500–900 °C. Calculate the percentage of CaCO₃ in the sample.
7. A 250 mg hydrated sample of Na₂HPO₄ decreases to a mass of 145.7 mg after heating to 15 °C. What is the number of water hydration in Na₂HPO₄.

8. Draw a labeled diagram of the TG curve obtained by heating a mixture of 80 mg of $\text{CaC}_2\text{O}_4 \cdot \text{H}_2\text{O}$ and 80 mg of $\text{BaC}_2\text{O}_4 \cdot \text{H}_2\text{O}$ to 1200°C . Calculate the amount of all mass losses.

10.9 ANSWERS

Self Assessment Question

- Balance; furnace; unit for temperature measurements and control; and recorder.
- Common source of error in thermogravimetric are listed in Sec. 10.3.

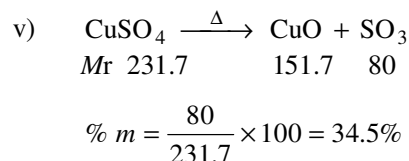
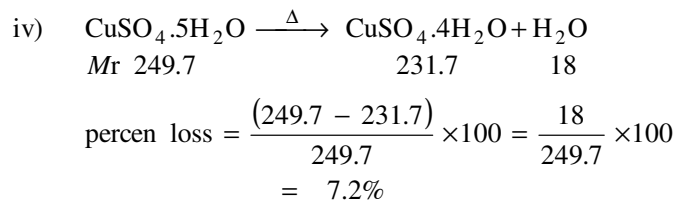
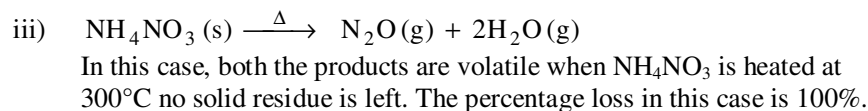
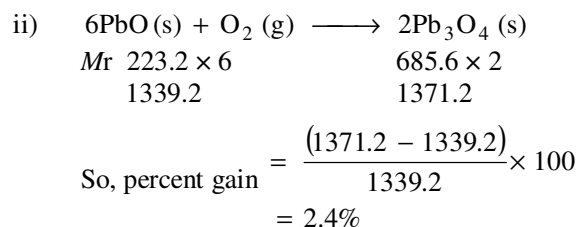
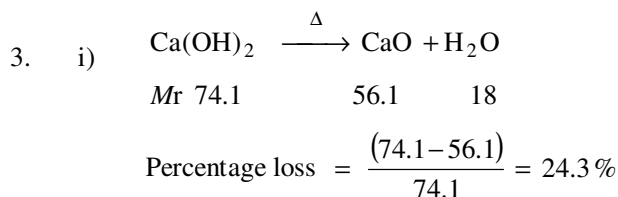

4. Decomposition reaction of the MgO , MgCO_3 and MgC_2O_4

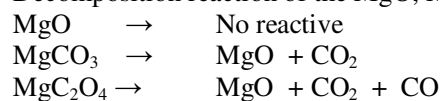

$$\% \text{ mass loss for } \text{MgC}_2\text{O}_4 = \frac{44}{84.3} \times 100 = 52.2\%$$

$$\% \text{ mass loss for } \text{MgCO}_3 = \frac{(44 + 28)}{112.3} \times 100 = 64.3\%$$

$$\% \text{ mass loss of the sample} = \frac{91.0}{175} \times 100 = 52\%$$

Therefore, this compound is MgCO_3 .

5. Instrumental factors: Furnace heating rate, recording chart speeds, furnace atmosphere, geometry of sample, holder/location of sensors, sensitivity of recording mechanism, composition of sample container, etc.

6. The possible decomposition in the mixture may be written as

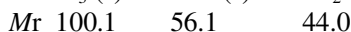

Mass loss in the mixture is due to the formation of CO_2 (g). We can calculate the m moles of CO_2 , i.e. $(250.6 - 19.8) \text{ mg}/44 = 1.359 \text{ mmol}$. From the above chemical equation, 1 mole of CaCO_3 give 1 mole of CO_2 . Therefore the amount of CaCO_3 in the mixture must be 1.359 mmol. This will equal to $= 1.359 \times 100.1 \text{ mg} = 135.9 \text{ mg}$.

So percentage of CaCO_3 in the sample will be $\frac{135.9}{250.6} \times 100 = 54.2\%$ by mass.

Terminal Questions

1. Reaction proceed in following steps

Above 60°C , it gradually decomposes into sodium carbonate and water and carbon dioxide.



Total calculated mass loss should be 36.9, dehydration is 10.71 and decarbonylation is 26.19. The observed mass loss is quite similar i.e. total 36.6, dehydration 11.2 and decarboxylation is 25.4%.

2. As per observation, under vacuum the mass loss at lower temperature range is because of thermal degradation of rubber and gives major mass loss of 66.41%. The addition of air at 950°C causes the carbon black to undergo the combustion to produce the second loss in mass, leaving in the balance pan only inert filler.

3. The exothermic peak at 590°C without mass loss is undoubtedly because of a phase change ($\alpha \rightarrow \beta$). The small peak at 900°C is due to recrystallization and at 1180°C is for melting point. All the transitions are physical in nature and TGA is not observing any mass loss. The probable thermal decomposition is:

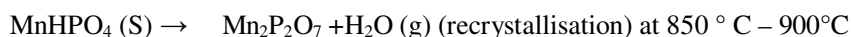
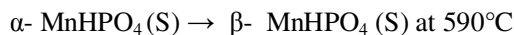
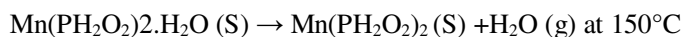

You can understand the significance of exothermic or endothermic peaks once you have gone through next Unit.

4. There are no standards available for TGA calibration. It is only possible to calibrate the balance using calibrated masses. However, it is possible to use some materials with known mass variations, such as copper sulphate pentahydrate or calcium oxalate, to check for good operation of the thermobalance. The latter materials are generally agreed as working standards but do not use the first mass loss, corresponding to the first hydrate.

5. Temperature calibration of the TGA requires the use of a metal that is 99.99% pure and magnetic. A magnet has to be adjusted on the TGA furnace. If the TGA is combined with a DTA or a DSC detector, see the DTA or DSC temperature calibration.

Thermal Methods

6. Write the decomposition reaction of CaCO_3

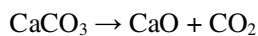

$$Mr \quad 100.1 \quad 56.1 \quad 44.0$$

This equation indicates that one mole of CaCO_3 produces one mole of CaO and one mole of CO_2 . Therefore,

$$m \text{ moles of } \text{CO}_2 = m \text{ moles of } \text{CaCO}_3$$

$$\begin{aligned} m \text{ moles of } \text{CO}_2 &= \text{mg lost}/Mr (\text{CO}_2) \\ &= (145.3 - 115.4) \text{ mg}/44.0 \\ &= 29.9/44.0 \\ &= 0.682 \text{ m moles} \end{aligned}$$

$$m \text{ moles of } \text{CaCO}_3 = 0.982 \text{ m moles}$$

$$\begin{aligned} \text{A amount of } \text{CaCO}_3 \text{ in sample} &= m \text{ moles of } \text{CaCO}_3 \times Mr (\text{CaCO}_3) \\ &= 0.682 \times 100.1 \text{ mg} \\ &= 68.2 \text{ mg} \end{aligned}$$

$$\% \text{ of } \text{CaCO}_3 = \frac{68.2}{145.3} \times 100 = 46.9 \%$$

7. Molar mass of hydrated Na_2HPO_3 is 215.9. We can calculate mass loss corresponding to each mole of hydrated water (n).

m % loss	8.8	16.7	25.0	33.3	41.7
n	1	2	3	4	5

$$\begin{aligned} \text{In this problem } \% \text{ mass loss} &= \frac{(250 - 145.7)}{250} \times 100 \\ &= 41.7\% \end{aligned}$$

This corresponds to a mass loss of 5 moles of water of (metallization. Therefore given sample must be of $\text{Na}_2\text{HPO}_3 \cdot 5\text{H}_2\text{O}$).

8. Table the help of Fig.10.12 to draw a labeled diagram of the TG curve for mixture of $\text{CaC}_2\text{O}_4 \cdot \text{H}_2\text{O}$ and $\text{BaC}_2\text{O}_4 \cdot \text{H}_2\text{O}$.

$$\begin{aligned} \text{Total mass loss} &= 49.3 (\text{CaC}_2\text{O}_4 \cdot \text{H}_2\text{O}) + 29.6 (\text{BaC}_2\text{O}_4 \cdot \text{H}_2\text{O}) \\ &= 78.9 \text{ mg.} \end{aligned}$$

References

1. H.H.Willard, L.L.Merrit Jr., J.A. Dean, F.A.Settle Jr., *Instrumental Method of Analysis*, Wadsworth Publishing Company, USA, 1986.
2. M.E. Brown, *Introduction to Thermal Analysis*, Kluwer Academic Publisher, London, 2001.
3. C.Duval, *Inorganic Thermogravimetric Analysis*, Elsevier Amsterdam, 1962.
4. P.D.Garn, *Thermoanalytical Methods of Investigations*, Academic Press, New York, 1965.
5. W.W. Wandlandt, *Thermal Analysis*, Wiley, New York, 1986.
6. A.Blazek, *Thermal Analysis*, Van Nostrand Reinhold, London, 1972.
7. H.Gunzzler and A.Williams, *Hand Book of Analytical Techniques*, Wiley – VCH, Weinheim, Vol -2, 2001.
8. G.W.Ewing, *Analytical Instrumentation Handbook*, Marcel Dekker Inc, New York, 1990.
9. R.A. Meyer, *Encyclopedia of Analytical Chemistry*, John Wiley & Sons Ltd, Vol 15, 2000.
10. Skoog, Douglas A., F. James Holler and Timothy Nieman. *Principles of Instrumental Analysis*. Fifth Edition. New York, 1998.
11. Dean, John A, *The Analytical Chemistry Handbook*. New York. McGraw Hill, Inc. 1995.
12. Brydson, J A, *Plastics Materials*, Butterworth-Heinemann, 7th Ed (1999).