



# Embraer Phenom 100

Taking the plunge into the purpose-built business jet market

By Fred George

**E**mbraer plans to rewrite the rules for how airframe manufacturers will compete in the business jet industry from 2008 to 2017. What's at stake? This will be a decade-long, Olympics-scale contest in which a dozen major players will compete for more than \$200 billion in new aircraft sales, according to the firm's internal projections. The Brazilian jet maker believes that its \$3.3 million Phenom 100,

its first purpose-built business jet, will be a game changer when the very light jet enters service before year-end.

When the first Phenom 100 customers take delivery in the next few months, they're going to find the aircraft has about as much in common with the VLJ class as Michael Phelps has with a learn-to-swim club at your local community pool.

First, the Phenom 100, like Phelps, is large. Its external dimensions almost put it into a class with Hawker Beechcraft's Premier IA. Similar to that Model 390, the Phenom 100 has an airstair door and its

four- to six-seat cabin has more head and shoulder room, plus more window area and more total volume, than the passenger compartment of a Cessna CJ1+ or Hawker Beechcraft King Air C90GT.

In addition, the Phenom 100 will cruise faster than most VLJs and it will have higher VMO/MMO limits. Embraer says the aircraft will fly as fast as 380 KTAS and it will push 275 KIAS in descents to maintain spacing with bigger jets arriving in busy terminal area airspace.

Unlike Phelps, however, this new light jet won't take gold in all categories. Runway

Photography courtesy of Embraer



**Strip away the paint and it's readily apparent that time-proven aluminum alloys are used for most of the Phenom 100's airframe structure.**

performance, for instance, is good but not class leading. The Phenom 100 will have a 3,400-foot sea-level standard-day FAR Part 23 Commuter Category takeoff field length. Top competitors need 5 to 10 percent less pavement using the same rules.

The Phenom 100 also won't have a lot more range than other VLJs, according to Embraer's performance projections. And similarly sized light jets will retain a clear edge in maximum range. Assuming a single pilot and four passengers, the Phenom 100 will be able to cruise 1,039 nm at an average speed of 314 KTAS, enabling it to fly between most city pairs in the continental United States with a single fuel stop. Embraer's long-range cruise speed estimates, and perhaps its range predictions, appear to be spot on, based upon what we recorded during our demo flight in Brazil in late July.

Embraer is counting on the Phenom 100's combination of cabin comfort, cruise speed, cockpit ergonomics and price to put it in the running for the entry-level light-jet class championship. It's also intent on making it

one of the most reliable, durable and maintainable business jets yet to enter service.

While the Phenom 100 is Embraer's first purpose-built turbofan business aircraft, it's simply the latest in a succession of jets designed in San Jose dos Campos. After producing several models of turboprop aircraft, Embraer successfully competed with archrival Bombardier in the 37- to 50-seat regional jet sector. Having reached parity with Bombardier in that arena, Embraer then upped the stakes by developing the 170/190-series E-Jets, aircraft that have set new standards for speed, comfort and efficiency in the 70- to 122-seat aircraft market.

But when the E-Jet development program was finished, Embraer decided not to challenge Airbus and Boeing with even larger jetliners. Instead, it redirected its engineering efforts toward building business jets, using the same core team that developed the E-Jets.

Wary of the competition from Cessna, Eclipse and Hawker Beechcraft, among other seasoned general aviation manufacturers, Embraer is applying all it has learned from commercial jets to its business jet product line. It is carrying over virtually the same design priorities it used to compete successfully in the jetliner market. Accordingly, you can expect the Phenom 100 to be tough, reliable and easy to maintain, emphasizing practicality, reliability and durability over all-out performance.

The Phenom 100's jetliner DNA, for example, is readily apparent. It will have a 35,000-cycle basic design life. Most business jets, in contrast, are designed for 15,000 to 20,000 flights. Ground testing has been far more rigorous than what most competitive

aircraft undergo, especially the VLJs. Each of the systems and several airframe parts are undergoing accelerated life-cycle testing on "iron bird" rigs to wring out the bugs before the aircraft enters service, thus minimizing teething pains among early serial number aircraft.

In addition, the Phenom 100's MSG 3 maintenance-friendly design has been fully validated by third-party maintenance technicians. Basic inspection intervals are 600 hours or 12 months, whichever comes first. One week is the most that is required for any major inspection.

Five aircraft are being used in the flight test campaign. As a result, there should be few, if any, IOUs when the aircraft enters service. Tests for RVSM, flight into known icing and cold weather, along with function and reliability, are complete. Cabin interior testing is under way.

Based upon such a balance of performance and cabin qualities, coupled with airliner ruggedness and reliability, Embraer believes it can unseat some of the long-reigning champions of the business jet industry. Probe into the details of this program and you may be able to determine its chances of taking home gold, silver or bronze.

### **High-Tech Tools, Low-Risk Materials and Systems**

Embraer has a long history of investing heavily in the latest computer-aided design and manufacturing tools to accelerate aircraft development. Phenom 100 designers, for instance, used the latest version of CATIA V5, along with many other Dassault Systemes CAD tools, to cut time and to improve productivity.

The fuselage cross-section has an

Embraer-original "Oval Lite" shape to optimize available room for seated passengers while minimizing external wetted area. The aft fuselage has many complex curves, including shallow recesses adjacent to the nacelles, intended to reduce high-speed "hot spots." Transonic flow in such areas otherwise would create wave drag.

The Phenom 100 has a wing of original design, one that doesn't reach its critical Mach number below its 0.70 MMO redline, so drag rise is relatively flat from long-range to high-speed cruise. The airfoil also has excellent high lift characteristics at slow speeds, particularly when its wide-span, large-area trailing edge flaps are extended. Moreover, a 2-percent higher lift coefficient was achieved when the wing fences were added early in the flight test development campaign.

However, the jet's T-tail configuration can result in some horizontal tail blanking at high angles of attack, especially at aft c.g., that can cause insufficient nose-down pitch at stall. So, the Phenom 100, similar to Embraer's Brasilia and Xingu turboprops and EMB 145 regional jetliner, has a stick pusher that fires precisely when the wing reaches maximum lift coefficient to assure stall recovery. Embraer engineers claim the stick pusher provides better defined and more consistent stall recognition for pilots than the anhedral tail fins fitted to many light jets.

The wing structure passes entirely below

the fuselage, so it doesn't intrude into the passenger cabin. The internal structure, a classic ladder design, has two main spars and chord-wise ribs that are attached to upper and lower stressed skins, reinforced by span-wise longerons. The forward attach point of the main landing gear is supported by a third sub spar in between the forward and aft main spars.

Most of the primary semi-monocoque airframe structure is built from conventional, high-strength alloy aluminum, using stretch-formed skins, chemically milled to reduce weight, mechanically fastened to machined or extruded hoop frames and longerons, plus some forged and milled components.

All those metal components would be labor-intensive to assemble, if Embraer had not invested heavily in robotic riveting tools at its Botucatu manufacturing facility, starting in mid-2006. Such automation helps reduce labor hours and thus manufacturing costs. After the Phenom 100 airframe parts are fabricated at Botucatu, they're transported about 100 miles north to Embraer's final assembly plant at Gaviao Peixoto, also home to its new flight test center.

Use of composites is limited mainly to secondary structures. Carbon fiber, for instance, is used to build the vertical and horizontal tail boxes, including internal spars and stressed skins. The vertical tail also has upper and lower chord-wise aluminum ribs. The front of the vertical tail

has a radio-wave transparent fiberglass fairing to accommodate an optional HF transceiver antenna. Carbon fiber and other composites are used for secondary structures, including aerodynamic fairings, the nose radome and some non-pressurized access doors.

Most airframe systems are simple and well-proven. The primary flight control surfaces, built from carbon fiber, are mechanically actuated. The horizontal tail is fixed in one position atop the vertical tail. Electrically actuated trim tabs are provided for the left aileron, rudder and both elevators. The airplane is fitted with redundant pitch trim actuators. The electrically controlled and actuated trailing edge wing flaps are the only secondary flight controls. Notably, the flaps use a control-by-wire system that synchronizes separate left and right DC-powered integrated drive flap jack screw actuators. There are no flex shafts or mechanical interlocks connecting the two flaps.

All fuel is contained in left and right wet wing tanks refilled through over-wing ports. Electrically powered boost pumps in left and right collector tanks, housed in dry sump canisters for easy removal and replacement, supply fuel for engine starting. During normal operations, fuel is supplied by jet pumps powered by excessive fuel from the engine-driven fuel pumps. An inter-tank transfer valve is used to equalize fuel quantity between the left and right wing tanks, if needed.

## Embraer Phenom 100

**BCA Equipped Price** .....\$3,300,000

### Characteristics

Seating .....1+5/7  
Wing Loading .....NA  
Power Loading .....3.09  
Noise (EPNdB) .....NA

### Dimensions (ft/m)

**External**  
Length .....41.7/12.7  
Height .....14.4/4.4  
Span .....40.4/12.3  
**Internal**  
Length .....11.0/3.4  
Height .....4.9/1.5  
Width (Maximum) .....5.1/1.6  
Width (Floor) .....3.6/1.1

### Power

Engine .....2 PWC PW617F  
Output (lb ea.) .....1,695  
Flat Rating .....ISA+10°C  
Inspection Interval (hr) .....3,500

### Weights (lb/kg)

Max Ramp .....10,516/4,770  
Max Takeoff .....10,472/4,750  
Max Landing .....9,766/4,430  
Zero Fuel .....8,444c/3,830c  
BOW .....7,100/3,221  
Max Payload .....1,344/610  
Useful Load .....3,416/1,550  
Executive Payload .....800/363  
Max Fuel .....2,804/1,272  
Payload With Max Fuel .....612/278  
Fuel With Max Payload .....2,072/940  
Fuel With Exec. Payload .....2,616/1,187

### Limits

MMO .....0.700  
FL/V<sub>MO</sub> .....280/275  
PSI .....8.3

### Climb

Time to FL 370 .....23 min.  
FAR 25 OEI Rate (fpm/MPM) .....NA  
FAR 25 OEI Gradient (ft/nm) .....NA

### Ceilings (ft/m)

Certificated .....41,000/12,497  
All-Engine Service .....41,000/12,497  
Engine-Out Service .....NA  
Sea Level Cabin .....21,800/6,645

**Certification** .....FAR Part 23 Pending

Note: All Data Preliminary

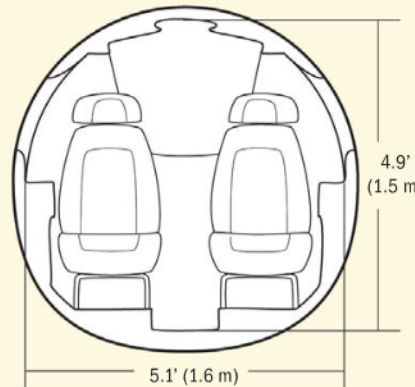

## Passenger Comfort and Convenience, Baggage Capacity

Similar to a jetliner, the Phenom 100 is an airplane wrapped around clearly defined cabin specifications. The airstair entry door, for instance, is the largest in its class, measuring 4.5 feet high by 2.1 feet wide. Optional LED tread lights illuminate each step. There also is a Type IV over-wing emergency exit on the right side of the airplane. The cabin windows, measuring 1.2 feet high by 1.0 feet wide, are the largest in this airplane class by a large margin.

The Phenom 100's 282-cubic-foot cabin is wider, taller and more voluminous than that of a CJ1+ or King Air C90GT. The overall cabin length is 1.4 feet shorter than the C90GT, but the net usable cabin is bigger because of the King Air's aft internal baggage compartment. There are three windows on each side of the main cabin, plus two more in the lavatory compartment. An abundance of natural light makes the cabin look larger than its actual dimensions.

The Phenom 100 has 62 cubic feet of baggage capacity, including a 45-cubic-foot aft external baggage compartment that can accommodate four roll-on bags, garment bags and four carry-on bags, plus four sets of golf clubs or four pairs of 185-mm-long skis. Inside the airplane, there is a six-cubic-foot carry-on luggage locker located behind the copilot's seat and a five-cubic-foot luggage compartment in the lavatory. There also are magazine pockets at each seat.

There is an additional five-cubic-foot external baggage compartment in the nose, useful for storing duct covers, crew baggage and miscellaneous stores.

Four interior configurations are available, the most popular of which features an executive four-seat center club layout with left- and right-side foldout worktables. A fifth, forward, side-facing seat is available as an option that replaces the forward luggage compartment. Special air taxi

configurations, featuring either four or six forward-facing seats at 35-inch pitch also are offered. A belted potty seat, certified for full-time occupancy, is available for the four- and five-seat executive and air taxi configurations. The lav has an internally serviced, recirculating flush toilet with removable waste tank. Replacing the standard lavatory compartment partition curtain, solid pocket doors are a 55-pound, \$28,850 option. The six-seat air taxi configuration, however, eliminates the lavatory compartment.

The standard cabin package includes an XM satellite radio receiver and an ATC monitoring channel that enables passengers to keep abreast of what's happening in the cockpit. Options include a high-fidelity cabin speaker package, CD/MP3 player, MP3 input jack and a master station for cabin light, audio and temperature control.



The 28 VDC split bus electrical system features separate forward and aft 24 VDC lead-acid batteries for system/avionics power and for engine start. Isolating the start and systems batteries assures "no break" power transfer to the avionics during engine start and when the generators come on line. Each engine has a starter/generator that powers the left or right side buses. Automatic bus tie and automatic load shedding functions are incorporated to ease pilot workload. A solid-state inverter provides 117 VAC 60 Hz power for eight utility outlets in the cockpit and cabin. All circuit breakers are conventional magnetic or thermal mechanical devices. The batteries provide 45 minutes of emergency power for essential equipment.

The trailing-link main landing gear legs have single wheels, as does the nose gear. Mechanical linkages through the rudder pedals provide nosewheel steering, augmented by differential braking. The landing gear actuators and wheel brakes are the only two hydraulic systems. An on-demand, electric pump supplies 3,000 psi pressure for those two systems. The Phenom 100 has a brake-by-wire system, similar to the systems used aboard Embraer's jetliners. A hydraulic accumulator provides power for six emergency brake applications. It also provides power for the parking brake. Gravity free-fall and air loads are used for emergency landing gear extension.

Engine bleed air is used for the 8.3-psi

pressurization system with separate sides that provide individual temperature control for cockpit and cabin. Pressurization control is fully automatic through the FMS, with provision for manual input of landing field elevation. Cabin heat is furnished by bleed air and a vapor-cycle air-conditioner provides refrigeration. A 50-cubic-foot capacity supplemental oxygen system provides a full-time supply to quick-donning masks in the cockpit and drop-down masks in the passenger compartment that automatically deploy if the cabin altitude exceeds 14,500 feet.

Bleed air and electrical heat is used to provide ice protection. Pneumatic boots, inflated by bleed air, provide de-ice protection for the leading edges of the

wings and horizontal stabilizer. Bleed air heat also protects the engine inlets from ice accumulation. Electrical heat is used for windshield, pitot tube, static port and angle-of-attack probe anti-icing.

Long-life LEDs are used for most exterior and interior lighting. Cabin lighting includes reading, overhead wash and aisle lights. The exceptions are the HID landing/taxi lights and a single halogen incandescent light used to illuminate the left wing leading edge for ice detection.

### Flying the Phenom 100

Less than one year after the Phenom 100's first flight on July 27, 2007, Embraer invited us to be the first to fly it, outside of company test pilots and certification authorities. Senior flight test pilot Antonio Bragança Silva and flight test engineer Maximillian Kleinubing accompanied us on what would be a two-hour, 44-minute mission in s.n. 500-801, the same aircraft that made the first flight.

During the walk-around, Bragança pointed out numerous design features that make the Phenom 100 easy to maintain and operate. A central diagnostic computer, for



*Long travel, trailing-link landing gear result in smooth touchdowns and a comfortable ride while taxiing over rough surfaces. The Meggitt brake-by-wire system, however, needs fine-tuning to provide better anti-skid performance.*

instance, monitors all main aircraft systems, logging health trends and anomalies. Ample sized access doors in the nose and aft fuselage provide access to systems components and fluid service points. The forward and aft batteries are easily accessible for removal and replacement. Windshield changes take two hours. All the probes are externally mounted for easy maintenance access. The fuel boost pumps

have low-maintenance brushless DC motors and they can be changed without defueling the aircraft. Brushless motors also are used for the flap actuators, cabin blowers and hydraulic power pack.

Kleinubing did all the hard preparatory work for the flight. He also recorded the results and produced a detailed log. Our aircraft was loaded with orange flight test instruments inside its barren shell cabin. Loaded with 2,215 pounds of fuel and the three of us, ramp weight was 10,389 pounds or 92 percent of the production aircraft's soon-to-be-certified ramp weight.

Boarding the aircraft is easy because of the sturdy airstair door and wide entryway. Belting into the left seat, it's apparent that the aircraft sits relatively high on its landing gear, compared to other VLJs and many light jets. It appears to be as high as the Premier IA.

Hands and eyes fall readily to controls, thanks to top-notch cockpit ergonomics, an especially important factor since the aircraft will be certified for single-pilot operation. Embraer's quiet, dark cockpit philosophy, honed through development of several generations of airliners, is readily apparent and it works. With lights out, aural alarms silenced and knobs at twelve o'clock, all systems are go for the applicable phase of flight. We also were impressed with the subtle use of color on the Prodigy Flight Deck 100 displays. Each colored symbol, graphic or number represents essential information. Colors are not used for aesthetics or decoration.

Kleinubing skipped the runway performance calculations because of the airport's 16,295 feet of available pavement. He computed V speeds, based upon a flaps 1 (10 degrees) configuration, 3,429-foot field elevation of Gavião Peixoto — Guarapuava (SBGP) airport and 24°C OAT. V1 was 89 KIAS, rotation was pegged at 105 KIAS and 108 KIAS was the V2 OEI takeoff safety speed. Flap retraction speed was 129 KIAS. V speeds are digitally displayed on the PFD prior to their coming into view as bugs on the airspeed tape. Operators will have to look up runway data in the AFM unless they purchase the optional EFB.

Engine start is simple. We turned on both batteries, positioned the generator control and fuel pump switches to auto and assured both throttles were in idle. Then, one at a time, we lifted and twisted the engine control knobs to the full right start position. The FADECs handled all other chores. As the engines started, each engine control knob automatically clicked into the normal, twelve o'clock run position, providing audible and tactile feedback of a successful engine start.

Prior to taxi, we checked the stall stick

## Pratt & Whitney Canada PW617F Turbofan Engines

Rated at 1,695 pounds of thrust to ISA+10°C, the PW617F is a scaled-up version of the PW615F that powers the Citation Mustang with hot section durability improvements added to withstand the rigors of the high-cycle operating environment of air taxi operations. An automatic performance reserve feature boosts engine output to 1,777 pounds of thrust in the event of engine failure on takeoff, if APR is armed prior to takeoff roll. The higher thrust rating also is available with both engines operating, if APR is armed and the pilot pushes up the throttles to the full max thrust position. The pilot also must dial in OAT prior to taking the runway to ensure proper thrust output on takeoff.

The engine is a FADEC-equipped, two-spool turbofan, featuring a wide-chord, damper-less single-piece fan powered by a single low-pressure turbine. The high-pressure section features a uniquely designed axial/centrifugal flow first-stage compressor plus a centrifugal flow second-stage compressor, along with a reverse flow annular combustor and a single high-pressure turbine. Overall bypass ratio is 2.7:1. Core and bypass flows are combined in a deep-fluted mixer nozzle to reduce noise and improve high-altitude cruise thrust output.

The Phenom 100 also will have a cruise control feature. If the autopilot is engaged and altitude hold mode is in use, the cruise control will adjust engine thrust +/-5 percent N1 to hold a selected speed. A green arc on the N1 engine instrument display will indicate the range of thrust control authority. Cruise control is strictly a FADEC function and the throttles are not back-driven to provide tactile feel of thrust adjustments.

Net engine weight is 376 pounds. Scheduled hot section inspection and overhaul intervals are 1,750 hours and 3,500 hours.

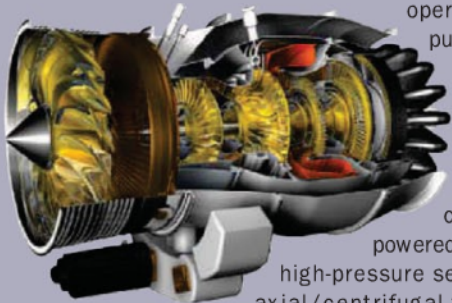

## Garmin Prodigy Flight Deck 100 Avionics

The Phenom 100's Prodigy avionics package is a highly evolved and customized version of the Garmin G1000 system used in other light turboprop aircraft, including the Cessna Citation Mustang, HondaJet and soon the PiperJet.

Embraer chose to fit the aircraft with three identical 12-inch AMLCDs having the same basic internal functionality. Any of them can assume the identity of a primary flight display or multifunction display. Using reversionary modes, this design feature allows the aircraft to be dispatched with one of the three displays inoperative.

Synthetic vision will be a standard feature on the PFDs and the MFD will display engine instruments, along with interactive electrical, environmental/pressurization, fuel and anti-ice systems synoptic diagrams, plus advisory-only electronic charts.

Intuitive and consistent use of color makes it easy to become comfortable with Prodigy. Cyan denotes a pilot-selected value or function. Magenta means the data or symbol is computer- or FMS-generated. Green signifies an active function or short-range nav generated data. White is used for labels and advisory data. Red and yellow are reserved for warning and caution alerts. Alternating between normal and reverse video is used to attract the pilot's attention to abnormalities.

Prodigy has plenty of redundancy, more than most other light jet aircraft. This starts with dual hub-and-spoke configuration main remote-mounted computers that host the VHF comm and nav radios, GPS, FMS, TAWS, Mode S TIS-B traffic advisory system and digital flight guidance system, along with numerous analog, digital and discrete inputs/outputs. The FMS/GPS will provide lateral and vertical navigation functions, including WAAS LNAV+V, LNAV/VNAV and LPV approach guidance. The FMS will be capable of providing guidance for virtually all ARINC 424 procedures. The database will contain virtually all published waypoints and it will have airways/jetways to speed flight planning chores.

Connected to the host computers are dual AHRS, dual digital air data computers, dual audio panels, a single Mode S transponder, FMS keyboard, digital combined voice and flight data recorder, angle-of-attack sensor and digitally controlled autopilot servos, plus an XM satellite radio weather data link. Notably, Garmin's GWX68 onboard weather radar is not standard equipment for U.S. customers. It's a \$28,879 option. Honeywell's KN63 DME is available for \$14,188 and TCAS 1 also will be offered at a price yet to be announced. Weather radar, DME and TCAS 1, however, are standard on European-spec airplanes, along with other equipment required for EASA certification.

Other avionics options include Iridium satcom, L-3 Stormscope, HF transceiver with SELCAL, ADF, data link management unit and ADF receiver, along with a second DME (\$14,188) and second Mode S diversity transponder (\$23,840). Embraer also will offer an optional stand-alone electronic flight bag with an electronic charts display that will provide the required redundancy to qualify for a paperless cockpit capability. The EFB also will host electronic versions of all required aircraft operating publications, runway performance and V speed computer and computer flight planning.

The Prodigy flight deck also includes a Thales integrated emergency standby instrument mounted directly in front of the pilot, just left of the flight guidance control panel in the glareshield. This solid-state unit provides a third display for attitude, air data and ILS. But it's not just an autonomous standby instrument. It's also able to provide a third source of AHRS and air data to the main Garmin 12-inch displays, should both of the main AHRS and digital air data computers fail. We know of no other light jet that offers such triple AHRS and air data source redundancy for the main cockpit displays.





The airstair entry door is the largest in class, measuring 4.5 feet high by 2.1 feet wide. A pressure-relief vent door assures the cabin is depressurized before the door is unlatched.

pusher and flight control movement. Out of the chocks, we noted that brake pedal pressure was heavy, quite similar to that of the EMB 145. Nosewheel steering was very positive. There was some chattering of the wheel brakes during taxi to Runway 20.

Just prior to taking the runway, we checked the MFD status page for doors, batteries, hydraulic system pressure, oxygen quantity and emergency brake accumulator pressure, along with flight data including aircraft weight, time, fuel quantity and air data.

Because of all the orange test gear and real-time telemetry, we obtained extra demo flight details not usually available. Actual takeoff weight at rotation, for instance, was 10,330 pounds and we used a 30-pound pull on the yoke to set initial pitch attitude. The

c.g. change with fuel burn during the entire flight was never more than half a percent, so there will be no weight-and-balance surprises for operators either en route or at the destination, if their aircraft are properly loaded prior to engine start.

We used a 200 KIAS/0.55 Mach climb schedule for a direct climb to FL 390. Transition altitude between the two speeds was FL 300. We reached FL 390 in 34 minutes and burned 554 pounds of fuel from the start of the takeoff roll.

During the climb we checked short period pitch and roll stability. The aircraft was adequately damped in pitch, but light turbulence caused slight pitch changes that needed to be corrected. Aerodynamic Dutch roll damping was just satisfactory,



The aft external baggage compartment will hold 45 cubic feet of gear, including four sets of golf clubs or four pairs of skis. Production aircraft will have a baggage door that hinges open from the leading edge rather than swinging up, thereby improving access to the compartment.

but the yaw damper made a substantial improvement.

We checked long-range cruise speed and fuel flow at FL 390. At a weight of 9,629 pounds, the aircraft cruised at 340 KTAS while burning 594 pph. When Kleinubing ran those numbers through Embraer's OASYS computer, the data confirmed the cruise performance for a mid-weight aircraft at long-range cruise at FL 410. The aircraft will achieve its advertised 0.611 nm/lb at 316 KTAS. But slowing to the predicted best long-range cruise speed of 335 KTAS at FL 390 for that weight, fuel economy actually went down. Based upon our observations, the aircraft actually may cruise slightly faster at LRC and achieve marginally better specific range than OASYS predicts.

Next, we checked high-speed buffet margins. We rolled into a 55-degree bank angle and pulled back with 55 pounds of force to maintain level altitude at 1.9 g's. There was no sign of high-speed buffet, but as we slowed below 155 KIAS, we encountered low-speed accelerated stall buffet.

Long-period, or phugoid, pitch stability was well damped. The period was one minute and each cycle resulted in about 10 knots less airspeed excursion. Spiral stability also was a strong point. We rolled into 30-degree bank angles and the aircraft stabilized with no tendency to roll off.

We then descended to FL 310 to check max cruise speed performance. At an average weight of 9,330 pounds and in ISA+9°C conditions, the aircraft achieved 370 KTAS. Data reduction by Embraer indicated the airplane should have cruised at 358 KTAS. Thus, the firm's engineers are quite confident the aircraft will achieve 380 KTAS in ISA conditions at FL 350 at mid-cruise weights. Again, we believe they're being conservative.

We then descended to 15,000 feet for air work, including a series of stalls. A malfunctioning stick pusher required us to initiate stall recovery at the aural stall warning, rather than continuing to increase angle of attack to the maximum lift coefficient. Aircraft control and stall recovery were completely comfortable in each configuration, but an objective critique, including actual stall speeds and handling characteristics was not possible.

After completing the airwork, we flew an ILS approach to Runway 2C at Piracununga — Campo Fontenelle, a military facility 61-nm east of Gavião Peixoto. Kleinubing computed VREF at 95 KIAS, based upon an aircraft weight of 8,900 pounds and flaps fully extended (36 degrees).

Extending the landing gear produced a little nose-up pitch transient and extending the flaps produced a substantial increase in



lift that we countered by pushing down firmly on the yoke and retrimming the elevator.

We attempted to fly the approach coupled, but terrain interference caused severe scalloping of the glideslope signal. This resulted in momentary triggering of the stall warning system, which caused the flight director to vanish and the autopilot to disengage. So we elected to fly the remainder of the approach by hand. We noted again that turbulence caused some slight nose pitch upset, requiring active correction to pitch attitude.

Flying back to Gaviao Peixoto, we flew two circuits. The first was a normal landing at 8,500 pounds with a 93 KIAS VREF speed. The aircraft exhibited docile handling characteristics in the pattern, and outside visibility from the left seat was excellent, at least for left-hand patterns. We didn't have the chance to fly any right patterns. Touchdown was gentle because of the aircraft's long-travel, trailing-link main landing gear.

After a full-stop landing, we flew a simulated OEI takeoff at a weight of 8,400 pounds and using flaps 1 (10 degrees). Computed V speeds were 87 KIAS for V1, 90 KIAS for rotation and 98 KIAS for V2. Brangança pulled back the right thrust lever just after rotation. Maximum left rudder pedal force was 75 pounds to counter the resulting yaw.

Cleaning up the aircraft, we climbed out at 650 fpm and made a short pattern return

to Runway 20 for a full stop landing. Using flaps 2 (26 degrees) and a VREF + 10 speed of 103 knots, the aircraft required mostly idle power during final approach to maintain speed.

We intentionally touched down firmly in preparation for a maximum performance stop. After touchdown, we pressed down fully on the brake pedals to evaluate the brake-by-wire system. The Meggitt ABS BBW system, however, provided less than optimum anti-skid action. Soon, the aircraft wheels started to lock up and release as though it were equipped with a conventional, albeit older-generation analog anti-skid system. The aircraft started to veer to the left, so we relaxed brake pedal pressure and used normal braking, along with nosewheel steering, to maintain directional control.

We attempted to contact Meggitt ABS officials in Ohio for answers, but we were unable to get anything other than an answering machine after multiple tries.

Total fuel burn for the two-hour, 44-minute flight was 2,031 pounds. Our overall impression was that the Phenom 100 is very easy to fly, having one of the most intuitive cockpits of any business aircraft yet produced, docile handling manners and simple, reliable systems. However, it's a little short-coupled in pitch and the brake-by-wire system needs fine-tuning.

#### **Is It an Olympic-Class Champion?**

We now have world-record performance numbers for Michael Phelps, but the

Phenom 100 has yet to prove itself in front of the international aviation community. Initial predictions look promising, but the lack of final performance charts and a comparison profile accompanying this report will require verification of the Phenom 100's performance potential in the coming months.

Embraer, being a traditional airliner manufacturer, is prone to being very conservative about releasing performance data until they are fully validated through flight test. From what we observed during our flight in July, we believe the aircraft's performance will live up to customer expectations.

The Phenom 100's reliability, durability and maintainability, though, should exceed expectations by wide margins. It's clearly in the genes passed down from the Embraer jetliners. Just as importantly, the folks at Embraer are committed to winning a big share of the business jet market. They're experienced in building jets and they have focused prodigious resources on expanding into the business jet market. In their hunger to succeed, they have brought their company to prominence as a world-class aircraft manufacturer.

It's this energy, effort and focus, as well as Embraer's jetliner engineering experience, that give the Phenom 100 the potential to excel. Looking forward to its initial entry into service in the next few months, the general aviation industry will be watching closely to see if the Phenom 100 indeed sets new records. ■