

1953-1956

# The Reines-Cowan Experiments

## *Detecting the Poltergeist*



Hanford Team 1953

### Savannah Team 1955



The Hanford Team: (on facing page, left to right, back row) F. Newton Hayes, Captain W. A. Walker, T. J. White, Fred Reines, E. C. Anderson, Clyde Cowan, Jr., and Robert Schuch (inset); not all team members are pictured.  
 The Savannah River Team: (clockwise, from lower left foreground) Clyde Cowan, Jr., F. B. Harrison, Austin McGuire, Fred Reines, and Martin Warren; (left to right, front row) Richard Jones, Forrest Rice, and Herald Kruse.

In 1951, when Fred Reines first contemplated an experiment to detect the neutrino, this particle was still a poltergeist, a fleeting yet haunting ghost in the world of physical reality. All its properties had been deduced but only theoretically. Its role was to carry away the missing energy and angular momentum in nuclear beta

decay, the most familiar and widespread manifestation of what is now called the weak force. The neutrino surely had to exist. But someone had to demonstrate its reality. The relentless quest that led to the detection of the neutrino started with an energy crisis in the very young field of nuclear physics.

### The Missing Energy and the Neutrino Hypothesis

During the early decades of this century, when radioactivity was first being explored and the structure of the atomic nucleus unraveled, nuclear beta decay was observed to cause the transmutation of one element into another. In that process, a radioactive nucleus emits an electron (or a beta ray) and increases its positive charge by one unit to become the nucleus of another element. A familiar example is the beta decay of tritium, the heaviest isotope of hydrogen. When it undergoes beta decay, tritium emits an electron and turns into helium-3.

The process of beta decay was studied intensely. In particular, scientists measured the energy of the emitted electron. They knew that a definite amount of nuclear energy was released in each decay reaction and that, by the law of energy conservation, the released energy had to be shared by the recoil nucleus and the electron.

The requirements of energy conservation, combined with those of momentum conservation, implied that the electron should always carry away the same amount of energy (see the box "Beta Decay and the Missing Energy" on the facing page). That expectation seemed to be borne out in some experiments, but in 1914, to the great consternation of many, James Chadwick showed definitively that the electrons emitted in beta decay did not have one energy or even a discrete set of energies. Instead, they had a continuous spectrum of energies. Whenever the electron energy was at the maximum observed, the total energy before and after the reaction was the same, that is, energy was conserved. But in all other cases, some of the energy released in the decay process appeared to be lost.

In late 1930, Wolfgang Pauli endeavored to save the time-honored law of energy conservation by proposing what he himself considered a desperate remedy" (see the box "The Desperate Remedy" on this page)—

### The Desperate Remedy

4 December 1930  
Gloriastr.  
Zürich

Physical Institute of the  
Federal Institute of Technology (ETH)  
Zürich

Dear radioactive ladies and gentlemen,  
As the bearer of these lines, to whom I ask you to listen graciously, will explain more exactly, considering the 'false' statistics of N-14 and Li-6 nuclei, as well as the continuous  $\beta$ -spectrum, I have hit upon a desperate remedy to save the "exchange theorem"\* of statistics and the energy theorem. Namely [there is] the possibility that there could exist in the nuclei electrically neutral particles that I wish to call neutrons,\*\* which have spin 1/2 and obey the exclusion principle, and additionally differ from light quanta in that they do not travel with the velocity of light: The mass of the neutron must be of the same order of magnitude as the electron mass and, in any case, not larger than 0.01 proton mass. The continuous  $\beta$ -spectrum would then become understandable by the assumption that in  $\beta$  decay a neutron is emitted together with the electron, in such a way that the sum of the energies of neutron and electron is constant.

Now, the next question is what forces act upon the neutrons. The most likely model for the neutron seems to me to be, on wave mechanical grounds (more details are known by the bearer of these lines), that the neutron at rest is a magnetic dipole of a certain moment  $\mu$ . Experiment probably required that the ionizing effect of such a neutron should not be larger than that of a  $\gamma$  ray, and thus  $\mu$  should probably not be larger than  $e \cdot 10^{-13}$  cm.

But I don't feel secure enough to publish anything about this idea, so I first turn confidently to you, dear radioactives, with a question as to the situation concerning experimental proof of such a neutron, if it has something like about 10 times the penetrating capacity of a  $\gamma$  ray.

I admit that my remedy may appear to have a small a priori probability because neutrons, if they exist, would probably have long ago been seen. However, only those who wager can win, and the seriousness of the situation of the continuous  $\beta$ -spectrum can be made clear by the saying of my honored predecessor in office, Mr. Debye, who told me a short while ago in Brussels, "One does best not to think about that at all, like the new taxes." Thus one should earnestly discuss every way of salvation.—So, dear radioactives, put it to test and set it right.—Unfortunately, I cannot personally appear in Tübingen, since I am indispensable here on account of a ball taking place in Zürich in the night from 6 to 7 of December.—With many greetings to you, also to Mr. Back, your devoted servant,

W. Pauli

\*In the 1957 lecture, Pauli explains, "This reads: exclusion principle (Fermi statistics) and half-integer spin for an odd number of particles; Bose statistics and integer spin for an even number of particles."

This letter, with the footnote above, was printed in the September 1978 issue of *Physics Today*.

\*\*Pauli originally called the new particle the neutron (or the "neutral one"). Later, Fermi renamed it the neutrino (or the "little neutral one").

## Beta Decay and the Missing Energy

In all types of radioactive decay, a radioactive nucleus does not only emit alpha, beta, or gamma radiation, but it also converts mass into energy as it goes from one state of definite energy (or equivalent rest mass M1) to a state of lower energy (or smaller rest mass M2). To satisfy the law of energy conservation, the total energy before and after the reaction must remain constant, so the mass difference must appear as its energy equivalent (kinetic energy plus rest mass energy) among the reaction products.

Early observations of beta decay suggested that a nucleus decays from one state to a state with one additional unit of positive charge by emitting a single electron (a beta ray). The amount of energy released is typically several million electron volts (MeV), much greater than the rest mass energy of the electron (0.51 MeV). Now, if a nucleus at rest decays into two bodies—the final nucleus and the electron—the law of momentum conservation implies that the two must separate with equal and opposite momentum (see top illustration). Thus, conservation of energy and momentum implied that the electron from a given beta-decay process would be emitted with a constant energy.

Moreover, since a nucleus is thousands of times heavier than an electron, its recoil velocity would be negligible compared with that of the electron, and the constant electron energy would carry off just about all the energy released by the decay.

The graph (center) shows the unexpected results obtained from experiment. The electrons from beta decay were not emitted with a constant energy. Instead, they were emitted with a continuous spectrum of energies up to the expected value. In most instances, some of the energy released in the decay appeared to be lost. Scientists of the time wondered whether to abandon the law of energy conservation when considering nuclear processes.

### Three-Body Decay and the Neutrino Hypothesis.

Pauli's solution to the energy crisis was to propose that the nucleus underwent beta decay and was transformed into three bodies: the final nucleus, the electron, and a new type of particle that was electrically neutral, at least as light as the electron, and very difficult to detect (see bottom illustration). Thus, the constant energy expected for the electron alone was really being shared between these two light particles, and the electron was being emitted with the observed spectrum of energies without violating the energy conservation law.

Pauli made his hypothesis in 1930, two years before Chadwick discovered the neutron, and he originally called the new particle the neutral one (or neutron). Later, when Fermi proposed his famous theory of beta decay (see the box "Fermi's Theory of Beta Decay and Neutrino Processes" on the next page), he renamed it the neutrino, which in Italian means the "little neutral one."

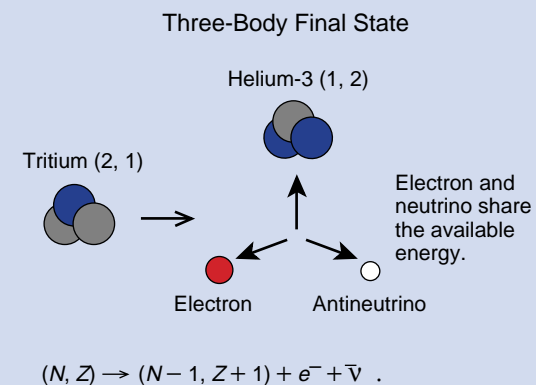
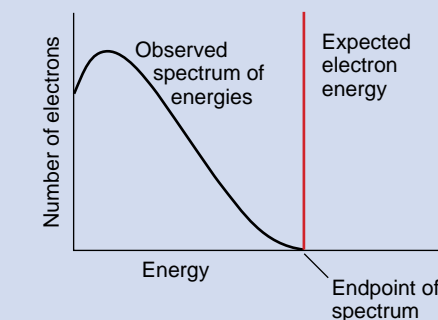
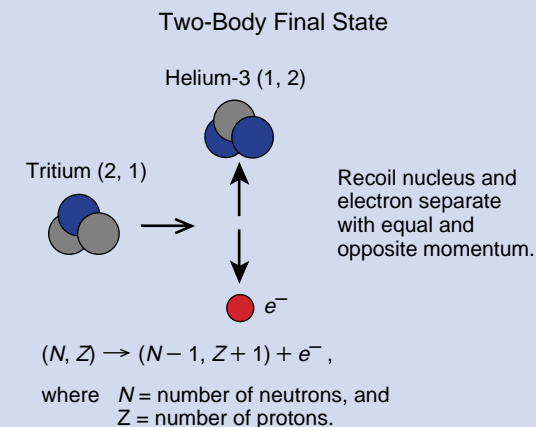



## Fermi's Theory of Beta Decay and Neutrino Processes

In 1934, long before the neutrino was detected in an experiment, Fermi gave the neutrino a reality by writing down his simple and brilliant model for the beta decay process. This model has inspired the modern description of all weak-interaction processes. Fermi based his model on Dirac's quantum field theory of electromagnetism in which two electron currents, or moving electrons, exert force on each other through the exchange of photons (particles of light). The upper diagram represents the interaction between two electrons. The initial state of the system is on the left, and the final state is on the right. The straight arrows represent currents, or moving electrons, and the wiggly line between the currents represents the emission of a photon by one current and its absorption by another. This exchange of a photon causes the electrons to repel each other. Note that the photon has no mass, a fact related to the unlimited range of the electromagnetic force.

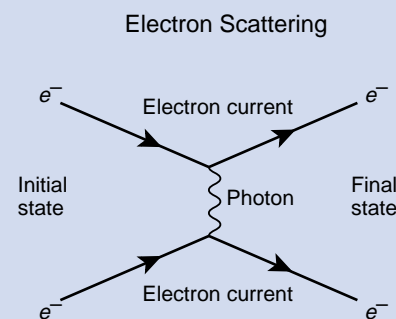

The fundamental process that takes place in beta decay (see lower diagram) is the change of a neutron into a proton, an electron, and an antineutrino. The neutron may be a free particle, or it may be bound inside the nucleus.

In analogy with quantum electrodynamics, Fermi represented beta decay as an interaction between two currents, each carrying the weak charge. The weak charge is related to the electric charge. Unlike the electromagnetic force, however, the weak force has a very short range. In Fermi's theory, the range of the force is zero, and the currents interact directly at a single point. The interaction causes a transfer of electric (weak) charge between the currents so that, for example, the neutron current gains one unit of charge and transforms into a proton current, while the electron current loses one unit of charge and transforms into a neutrino current.\*

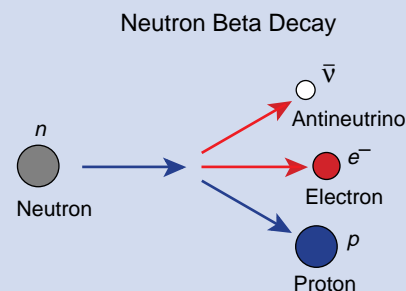

Because Fermi's theory is a relativistic quantum field theory, a single current-current interaction describes all weak-interaction processes involving the neutron, proton, electron, and neutrino or their antiparticles. As a result, we can represent all these weak-interaction processes with one basic diagram (on facing page, upper left corner).

\*In the modern theory, the currents interact through the exchange of the  $W$ , a very heavy particle analogous to the photon. The  $W$  carries one unit of electric charge and one unit of weak isotopic charge between the weak currents.

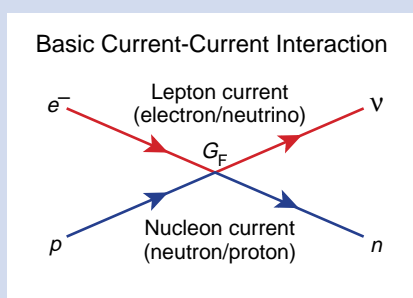

In analogy with the electric current, each weak current is depicted as a moving particle (straight arrow) carrying the weak charge. At the point where they interact, the two currents exchange one unit of electric (weak) charge.

One can adapt the basic diagram to each reaction by deciding which particles (or antiparticles) are to be viewed as the initial state and which as the final state. (Particles are represented by arrows pointing to the final state, whereas antiparticles point backward, to the initial state.) Since all the reactions described by the diagram stem from the same interaction, they have the same overall strength given by  $G_F$ , Fermi's constant. However, kinematic factors involving the amount and distribution of available energy and momentum

in the initial and final states affect the overall reaction rate. Three reactions are illustrated in the lower diagrams.

In the first reaction, neutron beta decay (lower left), the neutron starts out alone, but the interaction of two currents is responsible for the decay. The neutron (current) turns into a proton, and the charge is picked up by the electron/neutrino (current) that creates a particle (electron) and an antiparticle (antineutrino). Note that the direction of the arrow for the neutrino points backwards, to the initial state, to indicate that an antineutrino has appeared in the final state.

In the second reaction, electron capture (lower center), the initial state is a proton (current) and an electron (current). The weak interaction between the two currents triggers the exchange of one unit of charge so that the proton turns into a neutron while the electron turns into a neutrino. The reverse process is also possible.

In the third case, inverse beta decay (lower right), the initial state is an antineutrino (current) and a proton (current). The weak interaction between the two currents triggers the exchange of one unit of charge so that the antineutrino turns into an antielectron (positron) while the proton turns into a neutron. Again, the arrows pointing backward indicate that an antineutrino in the initial state has transformed into an antielectron in the final state. The reverse process is also possible.

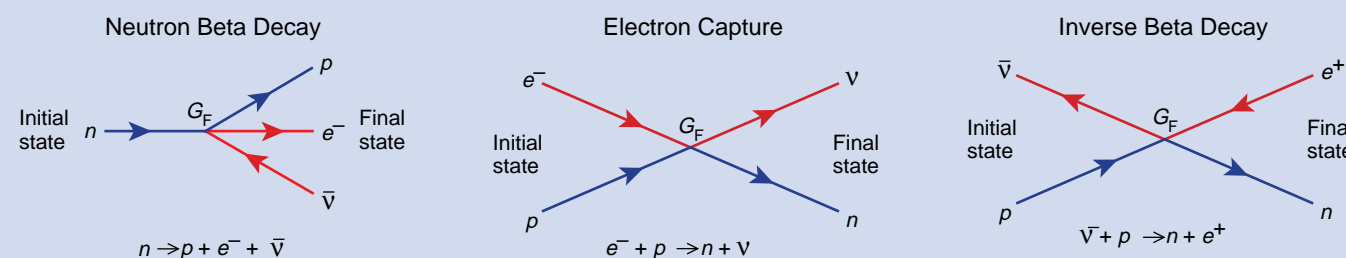

new subatomic particle that shares the available energy with the electron. To reduce the observed energy spectrum, his new particle, later named the neutrino ("little neutral one"), could have a mass no larger than that of the electron. Like electrons and protons, the only subatomic particles known at that time, it had to have no electric charge. And like electrons and protons, the only subatomic particles known at that time, it had to be a fermion, a particle having half-integer spin (or intrinsic angular momentum). It would therefore obey

the Pauli exclusion principle according to which no two identical neutrinos can be in the same state at the same time. Once created, the neutrino would speed away from the site at, or close to, the speed of light. But Pauli was concerned that the neutrinos he had postulated should have been already detected. Shortly thereafter, in a brilliant burst of insight, Enrico Fermi formulated a mathematical theory that involved the neutrino and that has endured with

little modification into the present. This theory postulates a force for beta decay and incorporates several brand-new concepts: Pauli's neutrino hypothesis, Dirac's ideas about the creation of particles, and Heisenberg's idea that the neutron and the proton were related to each other. In Fermi's theory of beta decay, this weak force, so called because it was manifestly much weaker than the electromagnetic force, turns a neutron into a proton and simultane-

ously creates an electron and an antineutrino (see the box on this page). The force can act on a free neutron or on a neutron bound inside a nucleus. Fermi's theory is remarkable in that it accounts for all the observed properties of beta decay. It correctly predicts the dependence of the radioactive-nucleus lifetime on the energy released in the decay. It also predicts the correct shape of the energy spectrum of the emitted electrons. Its success was taken

as convincing evidence that a neutrino is indeed created simultaneously with an electron every time a nucleus disintegrates through beta decay. Almost as soon as the theory was formulated, Hans Bethe and Rudolf Peierls understood that Fermi's theory of the weak force suggested a reaction by which a free neutrino would interact with matter and be stopped. As Bethe and Bacher noted (1936), "[I]t seems practically impossible to

detect neutrinos in the free state, i.e., after they have been emitted by the radioactive atom. There is only one process which neutrinos can certainly cause. That is the inverse beta process, consisting of the capture of a neutrino by a nucleus together with the emission of an electron (or positron). Unfortunately, the weak force is so weak that the probability of inverse beta decay was calculated to be close to zero. A target would have to be light-years

hick before it would have a good chance of stopping a neutrino. The possibility of detecting the neutrino seemed nil. But two things changed that prospect: first, the advent of very intense sources of neutrinos—fission bombs and fission reactors—and, second, the intense drive of a young man from New Jersey to make his mark in the world of fundamental physics.

### Fred Reines and Los Alamos

Fred Reines had become interested in mathematics and physics while studying at the Stevens Institute of Technology, and during graduate studies at New York University, he wrote his Ph.D. thesis elaborating on Bohr's liquid-drop model of nuclear fission. In 1944, he joined the Manhattan Project at Los Alamos and became a member of the Theoretical Division.

During the late forties and early fifties, after the first atomic bomb had been built at Los Alamos, the Laboratory's mission was intensely focused on building a reliable stockpile of fission weapons and developing the thermonuclear bomb. Reines was in charge of several projects related to testing nuclear weapons in the Pacific. In retrospect, Reines explains (unpublished notes for a talk given at Los Alamos):

“Bomb testing was an exercise in thinking big, in the ‘can do’ spirit. In the George Shot, for example, the signal cables running from the shot tower to the instrumentation bunker had to be shielded from the enormous gamma-ray flux from the explosion; otherwise, that flux would generate a huge current surge in those cables that would destroy all our electronics. The only thing available for shielding on the scale we needed was the island itself. So we dug up one side of the island and put it on top of the other.

“That can do spirit permeated our thinking. Whenever we thought about new projects, the idea was to set the most interesting (and fundamental) goal without initial concern as to feasibility

or practical uses. We could count on the latest technology being available to us at Los Alamos as a result of the instrumentation needs of the weapons program, and that fact fed our confidence. To his credit, Norris Bradbury, the Director who took over after Oppenheimer, lent enormous support to surrounding the nuclear weapons effort at Los Alamos with a broad scientific and technological base.”

The bomb-test steering and liaison group, in which Fred Reines participated, was interested in fundamental questions. New physics experiments that could be mounted as part of nuclear weapons tests were the topic of numerous free-ranging discussions in the group. It seemed appropriate that the unusually intense flux of thermal radiation, neutrons, and gamma rays produced by the bomb be used to study new phenomena.

The scientists in this group were even aware of the incredibly intense flux of antineutrinos produced when the fissioning, or splitting, of atomic nuclei during the neutron chain reaction gives rise to a host of unstable nuclei. The weak interactions then become important in changing the identity of those nuclei as they follow their decay paths to lower and lower energy states. Each fission event gives rise to an average of six beta-decay processes, each of which produces an antineutrino. Thus, those beta decays result in a short but intense burst of antineutrinos.

In 1951, Reines thought about using that intense burst in an experiment designed to detect the neutrino. He had returned from the very successful Greenhouse tests in Eniwetok Atoll, in the Pacific, and became captivated by the “impossible challenge” to detect the elusive free neutrino using neutrinos from the bomb. After having been involved for seven years in the weapons program, Reines asked J. Carson Mark, leader of the Theoretical Division, for some time to think about more fundamental questions.

The bomb was not only an intense neutrino source but also so short-lived

that the number of background events mimicking neutrino-induced events would be minimized. That summer, Reines mentioned his plan to Enrico Fermi and even described the need for what was then considered to be a very large scale detector. Reines estimated that a sensitive mass of about one ton would be needed to stop a few neutrinos. At the time, Reines did not know how to build such a large detector, and evidently, neither did Fermi. However, both Fermi and Hans Bethe thought that the bomb was the most promising neutrino source.

A few months later, Reines was able to interest one of his Los Alamos colleagues to participate in his quest. As Reines observed (unpublished notes), “It was my singular good fortune to be joined by Clyde L. Cowan, Jr., whom I had met in connection with Operation Greenhouse and who became my very stimulating and capable collaborator.”

Cowan had studied chemical engineering as an undergraduate and, during World War II, was awarded the Bronze Star for his work on radar at the British Branch of the Radiation Laboratory of the Massachusetts Institute of Technology. His Ph.D. thesis at George Washington University was on the absorption of gamma radiation. In 1949, he joined Los Alamos Scientific Laboratory. Like Reines, he became heavily involved in the weapons testing program in the Pacific. In late 1951, Reines and Cowan began “Project Poltergeist,” the first experiment in neutrino physics.

### The Signal of the Poltergeist

What happens when neutrinos enter matter? Most of the time, they pass straight through without scattering, but Fermi's theory of the weak force predicts that the neutrino can induce an inversion of beta decay (see the box “Fermi's Theory of Beta Decay and Neutrino Processes” on page 8). In particular, the antineutrino (the antiparticle of the neutrino) will occasionally

interact with a nucleus through the weak force and will induce the transformation of a proton into a neutron. This inverse of the usual beta-decay process results in a nucleus with one less unit of positive charge. That charge is picked up by the antineutrino, which transforms into a positron:

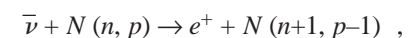

where  $n$  equals the number of neutrons and  $p$  equals the number of protons. If the nucleus happens to be that of hydrogen (a single proton), then the interaction produces a neutron and a positron:

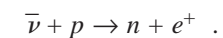

Reines and Cowan chose this latter reaction, the inverse beta decay on protons, to detect the free neutrino. The nuclear fission bomb would be their source of an intense flux of neutrinos (Figure 1). But they also needed to design a very large detector containing a sufficient number of target protons that would stop a few neutrinos. As Reines observed (unpublished notes),

“Our crude knowledge of the expected energy spectrum of neutrinos from a fission bomb suggested that the inverse beta decay reaction would occur several times in a several-ton detector located about 50 meters from the tower-based explosion of a 20-kiloton bomb. (Anyone untutored in the effects of nuclear explosions would be deterred by the challenge of conducting an experiment so close to the bomb, but we knew otherwise from experience and pressed on). The detector we dreamed up was a giant liquid scintillation device, which we dubbed ‘El Monstro.’ This was a daring extrapolation of experience with the newly born scintillation technique. The biggest detector until Cowan and I came along was only a liter or so in volume.”

Their initial scheme was to use the newly discovered, liquid, organic scintillators as both the target for the neutrinos (these liquids had a high proportion

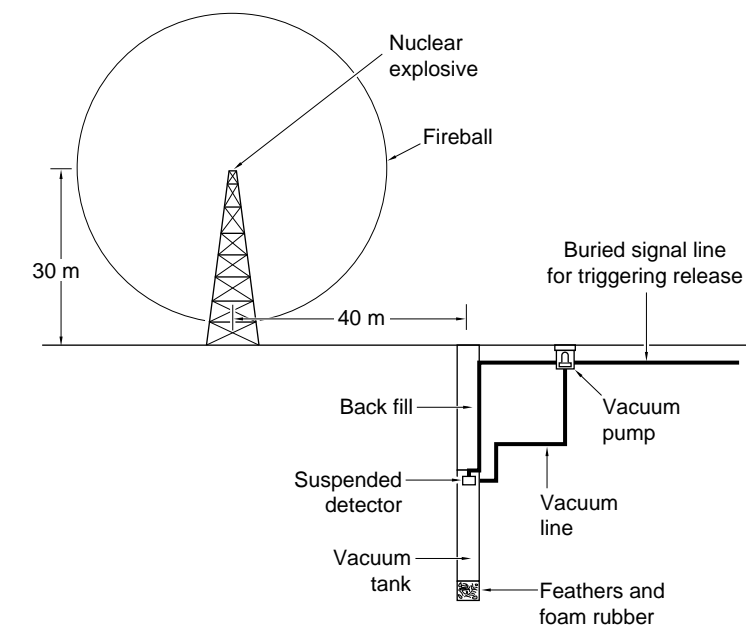

**Figure 1. Detecting Neutrinos from a Nuclear Explosion**

Antineutrinos from the fireball of a nuclear device would impinge on a liquid scintillation detector suspended in the hole dug below ground at a distance of about 40 meters from the 30-meter-high tower. In the original scheme of Reines and Cowan, the antineutrinos would induce inverse beta decay, and the detector would record the positrons produced in that process. This figure was redrawn courtesy of Smithsonian Institution.

of hydrogen) and the medium to detect the positron from inverse beta decay.

In 1950, several groups discovered that transparent organic liquids emit flashes of visible light when a charged particle or a gamma ray passes through them. These liquids had first been purified and then added to certain compounds. The light flashes are very weak but useful because their intensity is proportional to the energy of the charged particles or gammas. In a liquid scintillation counter, the light is collected by highly sensitive photomultiplier tubes located on the boundary of the detector. These phototubes convert light into electrical signals in proportion to the light intensity.

Figure 2 outlines the processes that would convert the energy of a positron from inverse beta decay into a measurable signal. The first small liquid-scintillation counters had already been developed, and one of those initial developers, F. B. (Kiko) Harrison, was at Los Alamos.

Wright Langham, leader of the Health Division's research group, had recruited Harrison to help design such counters for measuring radiation in biological samples. Harrison was one of the designers of the prompt-coincidence technique (see the section “The First Large Detector” on page 14) to distinguish spurious noise in the photomultiplier tubes from the signals generated by light flashes.

Once the idea for a new detector had been shaped, Reines and Cowan developed an audacious design for their experiments (shown in Figure 1). As Cowan (1964) vividly described it, “We would dig a shaft near ‘ground zero’ about 10 feet in diameter and about 150 feet deep. We would put a tank, 10 feet in diameter and 75 feet long on end at the bottom of the shaft. We would then suspend our detector from the top of the tank, along with its recording apparatus, and back-fill the shaft above the tank.

“As the time for the explosion

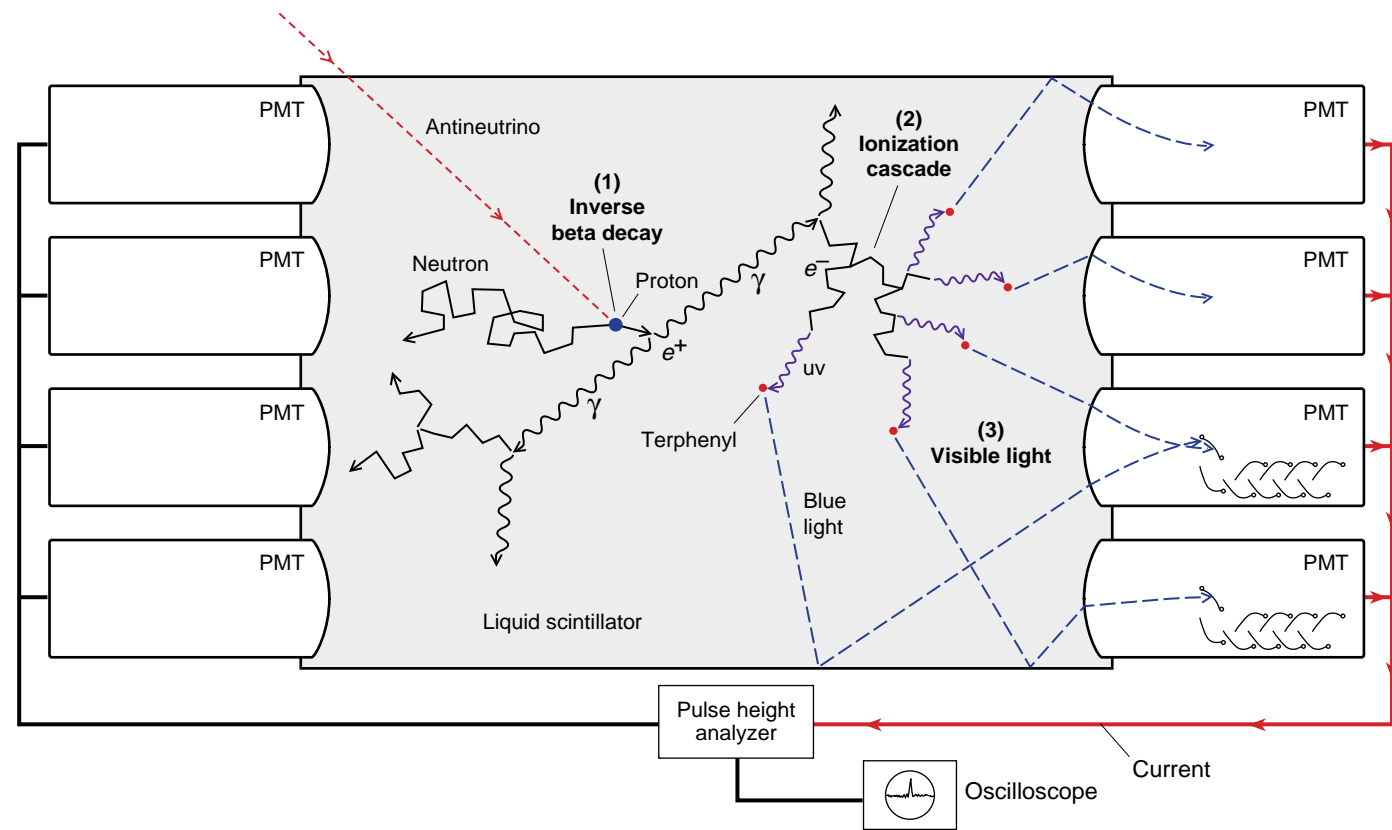

Figure 2. Liquid Scintillation Counter for Detecting the Positron from Inverse Beta Decay

Reines and Cowan planned to build a counter filled with liquid scintillator and lined with photomultiplier tubes (PMTs), the “eyes” that would detect the positron from inverse beta decay, which is the signal of a neutrino-induced event. The figure illustrates how the liquid scintillator converts a fraction of the energy of the positron into a tiny flash of light. The light is shown traveling through the highly transparent liquid scintillator to the PMTs, where the photons are converted into an electronic pulse that signals the presence of the positron. Inverse beta decay (1) begins when an antineutrino (red dashed line) interacts with one of the billions and billions of protons (hydrogen nuclei) in the molecules of the liquid. The weak charge-changing interaction between the

antineutrino and the proton causes the proton to turn into a neutron and the antineutrino to turn into a positron ( $e^+$ ). The neutron wanders about undetected. The positron, however, soon collides with an electron ( $e^-$ ), and the particle-antiparticle pair annihilates into two gamma rays ( $\gamma$ ) that travel in opposite directions. Each gamma ray loses about half its energy each time it scatters from an electron (Compton scattering). The resulting energetic electrons scatter from other electrons and radiate photons to create an ionization cascade (2) that quickly produces large numbers of ultraviolet (uv) photons. The scintillator is a highly transparent liquid (toluene) purposely doped with terphenyl. When it becomes excited by absorbing the uv photons, it scintillates

by emitting visible photons as it returns to the ground (lowest-energy) state (3). Because the liquid scintillator is transparent to visible light, about 20 percent of the visible photons are collected by the PMTs lining the walls of the scintillation counter. The rest are absorbed during the many reflections from the counter walls. A visible photon releases an electron from the cathode of a phototube. That electron then initiates the release of further electrons from each dynode of the PMT, a process resulting in a measurable electrical pulse. The pulses from all the tubes are combined, counted, processed, and displayed on an oscilloscope screen.

approached, we would start vacuum pumps and evacuate the tank as highly as possible. Then, when the countdown reached ‘zero,’ we would break the suspension with a small explosive, allowing the detector to fall freely in the

vacuum. For about 2 seconds, the falling detector would be seeing the antineutrinos and recording the pulses from them while the earth shock [from the blast] passed harmlessly by, rattling the tank mightily but not disturbing our falling

detector. When all was relatively quiet, the detector would reach the bottom of the tank, landing on a thick pile of foam rubber and feathers. “We would return to the site of the shaft in a few days (when the

surface radioactivity had died away sufficiently) and dig down to the tank, recover the detector, and learn the truth about neutrinos!”

This extraordinary plan was actually granted approval by Laboratory Director Norris Bradbury. Although the experiment would only be sensitive to neutrino cross sections of  $10^{-40}$  square centimeters, 4 orders of magnitude larger than the theoretical value, Bradbury was impressed that the plan was sensitive to a cross section 3 orders of magnitude smaller than the existing upper limit.<sup>1</sup> As Reines explains in retrospect (unpublished notes for a talk given at Los Alamos),

“Life was much simpler in those days—no lengthy proposals or complex review committees. It may have been that the success of Operation Greenhouse, coupled with the blessing given our idea by Fermi and Bethe, eased the path somewhat!”

As soon as Bradbury approved the plan, work started on building and testing El Monstro. This giant liquid-scintillation device was a bipyramidal tank about one cubic meter in volume. Four phototubes were mounted on each of the opposing apices, and the tank was filled with very pure toluene activated with terphenyl so that it would scintillate. Tests with radioactive sources of electrons and gamma rays proved that it was possible to “see” into a detector of almost any size.

Reines and Cowan also began to consider problems associated with scaling up the detector. At the same time, work was proceeding on drilling the hole that would house the experiment at the Nevada Test Site and on designing the great vacuum tank

<sup>1</sup>H. R. Crane (1948) deduced the upper limit of  $10^{-37}$  square centimeters on the cross sections for neutrino-induced ionization and inverse beta decay. This upper limit was based on null results from various small-scale experiments attempting to measure the results of neutrino absorption and from a theoretical limit deduced from the maximum amount of solar neutrino heating that could take place in the earth’s interior and still agree with geophysical observations of the energy flowing out of the earth.

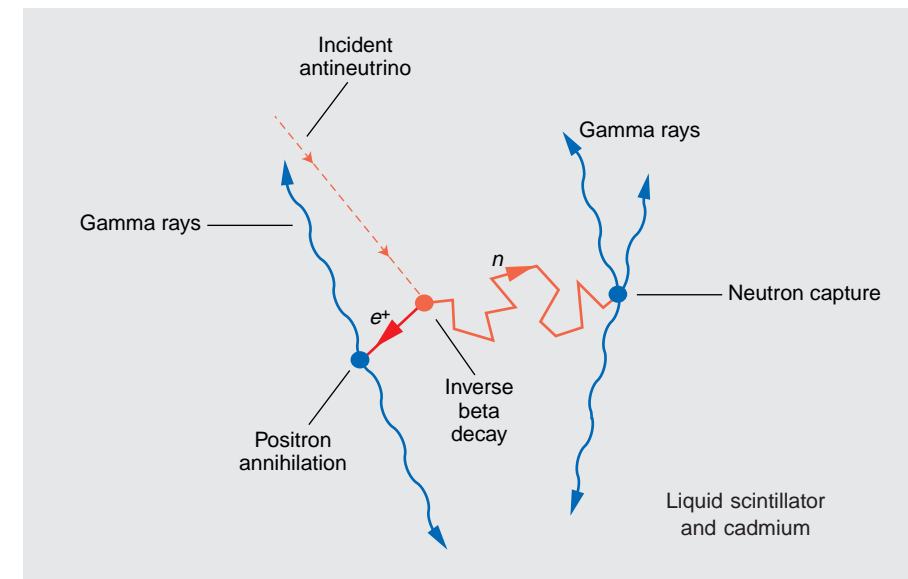

Figure 3. The Double Signature of Inverse Beta Decay

The new idea for detecting the neutrino was to detect both products of inverse beta decay, a reaction in which an incident antineutrino (red dashed line) interacts with a proton through the weak force. The antineutrino turns into a positron ( $e^+$ ), and the proton turns into a neutron ( $n$ ). In the figure above, this reaction is shown to take place in a liquid scintillator. The short, solid red arrow indicates that, shortly after it has been created, the positron encounters an electron, and the particle and antiparticle annihilate each other. Because energy has to be conserved, two gamma rays are emitted that travel in opposite directions and will cause the liquid scintillator to produce a flash of visible light. In the meantime, the neutron wanders about following a random path (longer, solid red arrow) until it is captured by a cadmium nucleus. The resulting nucleus releases about 9 MeV of energy in gamma rays that will again cause the liquid to produce a tiny flash of visible light. This sequence of two flashes of light separated by a few microseconds is the double signature of inverse beta decay and confirms the presence of a neutrino.

and its release mechanism. But one late evening in the fall of 1952, immediately after Reines and Cowan had presented their plans at a Physics Division seminar, a new idea was born that would dramatically change the course of the experiment. J. M. B. Kellogg, leader of the Physics Division, had urged Reines and Cowan to review once more the possibility of using the neutrinos from a fission reactor rather than those from a nuclear explosion. The neutrino flux from an explosion would be thousands of times larger than that from the most powerful reactor. The available shielding, however, would make the background noise from neutrons and gamma rays about the same in both cases. Clearly, the nuclear explosion was the best available approach—unless the background could somehow be further reduced. Suddenly, Reines and Cowan realized how to do it. The original plan had been to detect the positron emitted in inverse beta decay (see Figure 2), a process in which the weak interaction causes the antineutrino to turn into a positron and the proton to turn into a neutron. Being an antielectron, the positron would quickly collide with an electron, and the two would annihilate each other as they turned into pure energy in the form of two gamma rays traveling in opposite directions. Each gamma ray would have an energy equivalent to the rest mass of the



electron, namely, 0.51 million electron volt (MeV). The two gamma rays would accelerate electrons through Compton scattering and initiate a cascade of electrons that would eventually cause the liquid to scintillate. The tiny flash of visible light, efficiently converted into an electronic pulse, would be the signal of the positron.

The new idea was to detect not only the positron but also the neutron (see Figure 3). Once produced, the neutrons bounce around and slow down as they collide with protons. It can be captured by a proton to produce deuterium, or by heavy hydrogen. But if a nucleus such as cadmium is present, the neutron has a much greater chance of being captured. Adding a cadmium salt to the organic scintillator dramatically increases the cross section for absorbing (low-energy) neutrons. The capture process releases about 9 MeV of energy in gamma rays.

The average time between the flash of light from the positron-electron annihilation and that from the neutron capture is a few microseconds. Electronic circuits could be designed to detect this “delayed-coincidence” signature, two flashes of light (each within a well-defined energy range) separated by microseconds, and provide a powerful means to discriminate the signature of inverse beta decay from background noise. Thus, using the much smaller flux of reactor neutrinos became feasible. As Cowan (1964) remembers,

“Instead of detecting a burst of neutrinos in a second or two coming from the fury of a nuclear explosion, we would now be able to watch patiently near a reactor and catch one every few hours or so. And there are many hours available for watching in a month—or a year.”

### The First Large Detector

The group spent that winter building the detectors, developing various liquid-scintillator compositions, and testing the response of the detectors to gamma rays. Each detector

was about 28 inches in diameter and 30 inches high (see photo on this page), and 90 photomultiplier tubes penetrated its curved walls.

The phototubes were connected in two interleaved arrays, each of which would produce an electrical pulse in response to a light signal in the detector. The two pulses would then be sent to a prompt-coincidence circuit, which would accept them as a bona fide signal

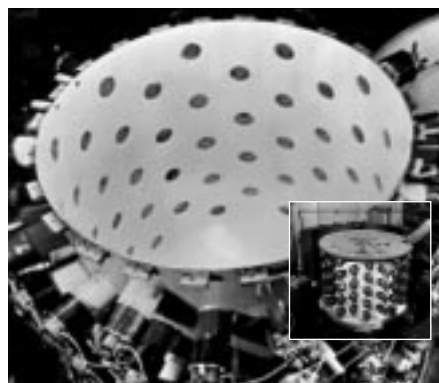

**The Hanford Neutrino Detector**  
The background photo is a top view of the neutrino detector used in the Hanford experiments. It shows the interior of the 10-cubic-foot vat for the liquid scintillator and the 90 photomultiplier tubes, each with a 2-inch-diameter face that had a thin, photosensitive surface. The inset is a side view of the detector. Having a 300-liter capacity, “Herr Auge” (German for Mr. Eye, as this detector was named) was the largest detector at the time.

only if they arrived simultaneously. That prompt-coincidence requirement helped eliminate counting the spurious dark current that arose spontaneously and at random in the phototubes themselves.

The team worked in an isolated, unheated building. Cowan (1964) reports how “some of our group swept the snow away from outside the building and set about casting many large blocks of paraffin wax and borax for use as neutron shielding when we would go to a reactor. Others began mixing gallons of liquid scintillator in batches with varying composition.”

They had to use electrical heaters to

keep the toluene scintillator warm; otherwise, it would turn from transparent to cloudy. Soon, they discovered that one of the brands of mineral oil carried by a local druggist, when mixed with suitable chemicals, could serve as another liquid scintillator. Having a hydrogen density different from that of toluene, the mineral oil would yield a different measured rate for inverse beta decay and thus provide a consistency check on the experiment—of course, if the experimental error could be made small enough to make the difference visible.

The threesome who carried the primary responsibility for developing and testing the detector were F. Newton Hayes, Robert Schuch, and Ernest C. Anderson from Wright Langham’s biomedical/health physics research group. Using various radioactive gamma-ray sources, they discovered that their large-volume liquid scintillation detectors were extremely efficient at detecting gamma rays, enough to revolutionize the counting of small amounts of radioactivity in bulk samples. The group realized they could test the radioactive content of the materials used to construct the detector and eliminate those that would add unduly to the background.

As Cowan (1964) reports, “We built a cylindrical well into one of the detectors and proceeded to put quantities of steel, liquids, wax, and other materials into it for testing. We found that brass and aluminum were quite radioactive compared to iron and steel, and that the potassium in the glass envelopes of our photomultiplier tubes would contribute to the detector backgrounds.

“During this time, one of our group, Robert Schuch, proposed making the well in the detector a bit larger so that we might be able to put a human being into the detector. This was done, and a number of people, including our secretary, were trussed up and lowered into the 18-inch hole. We found quite a detectable counting rate from everyone. It was due to the radioactive potassium-40 naturally present in the body.”

## The Whole-Body Counter



In 1956, Ernest C. Anderson, Robert Schuch, James Perrings, and Wright Langham developed the whole-body counter known as HUMCO I. Its design was a direct spinoff from the development of the first large liquid-scintillation detector used in Reines and Cowan’s neutrino experiments at Hanford. HUMCO I measured low levels of naturally occurring radioactivity in humans. Later, it was used in a worldwide effort to determine the degree to which radioactive fallout from nuclear tests and other nuclear and natural sources was absorbed by the human body. The detector consisted of a cylindrical container filled with 140 gallons of liquid scintillator and surrounded by 108 photomultiplier tubes. The person being measured was placed in a slide and drawn into the detector. Gamma rays emitted by the naturally occurring radioisotope potassium-40 or the fallout isotope cesium-137, for example, would largely penetrate the detector’s inner wall, excite the scintillator, and be detected. HUMCO II, which superseded HUMCO I in 1962, was nearly 10 times more sensitive, and its measurements were that much safer and quicker.

The top photo shows Anderson sitting at the controls of HUMCO II. To his right is the slide that would carry Schuch inside the detector for radioactive measurement.

In 1958, the human counter was demonstrated at the Atoms for Peace Conference held in Geneva. Built especially for this conference, the vertical counter was open on one side to allow a person to step in for measurement of internal radioactivity. The middle picture shows a conference participant getting ready to enter the detector under Newton Hayes’ supervision.

The lower picture and diagram show the first human-radioactivity measurements carried out in the detector that served as the basis for HUMCO. The original purpose of that detector had been different: to determine the degree to which the natural gamma-ray activity of the materials used to shield the Hanford neutrino detector would add “noise” to the experiments. Schuch suggested that a larger insert into the detector would allow a small person to be placed inside and then be measured for gamma-ray activity. Langham, shown crouched inside the detector, was the only member of the team slim enough to fit in the narrow space.



# The Hanford Experiment

1953



(b)



(d)

Amid the jumble of boxes and barrels, Los Alamos researchers were feverishly preparing for the Hanford experiment.

(a) F. Newton Hayes (left) and Clyde Cowan, Jr., discuss the search for the neutrino, while two workers (b) are shielding the face of the reactor to minimize the occurrence of background events. The top of Herr Auge, the neutrino detector, is shown surrounded by an incomplete shield made of boron-paraffin boxes and huge amounts of lead.



(c)



(e)

Work was exciting, exhausting, all-consuming. But there was always time for fun. In the menu composed by Hayes and Robert Schuch (c), silica gel, the chemical "jello," is offered as a tongue-in-cheek dessert together with green men cocktail, a reminder of the green-colored solution left from rinsing the whole system before the experiment could start. The chemicals listed on the menu are some of the actual ingredients used in preparing the liquid scintillators that would fill the detector. The barrels (d) were filled with scintillator solution after the chemicals had carefully been weighed with the scale pictured in (e). Hayes is filling empty barrels (f) with that solution. The barrels would then be hauled onto the storage truck. Schuch is connecting pipes to the storage truck (g) in preparation for transferring the liquid scintillator into the mixing trailer. The two rows of valves and pipes were inside the mixing trailer (h). Through these pipes and the supply lines (i), the scintillator solution would flow into the detector.

These photos are from Robert Schuch's private collection.



(f)



(g)



(h)



(i)



Schuch's idea gave birth to the Los Alamos total-immersion, or "whole-body," counter (see box "The Whole-Body Counter" on page 15), which was similar in design to the detector for Project Poltergeist but was built especially to count the radioactive contents of people. Since counting with this new device took only a few minutes, it was a great advance over the standard practice of using multiple Geiger counters or sodium iodide (NaI) crystal spectrometers in an underground laboratory. The Los Alamos whole-body counter was used during the 1950s to determine the degree to which radioactive fallout from nuclear tests and other nuclear and natural sources was taken up by the human body.

### The Hanford Experiment

In the very early spring of 1953, the Project Poltergeist team packed up Herr Auge, the 300-liter neutrino detector, as well as numerous electronics and barrels of liquid scintillator, and set out for the new plutonium-producing reactor at the Hanford Engineering Works in Hanford, Washington. It was the country's latest and largest fission reactor and would therefore produce the largest flux of antineutrinos. Various aspects of the setup at Hanford are shown in the photo collage.

The equipment for the liquid scintillator occupied two trucks parked outside the reactor building. One was used to house barrels of liquid; in a second smaller truck, liquid scintillators were mixed according to various recipes before they would be pumped into the detector. Herr Auge was placed inside the reactor building, very near the face of the reactor wall, and was surrounded by the homemade boron-paraffin shielding intermixed with nearly all the lead shielding available at Hanford. This shield was to stop reactor neutrons and gamma rays from entering the detector and producing unwanted background. In all, 4 to 6 feet of paraffin alternated with 4 to 8 inches of lead.

The electronic gear for detecting the telltale delayed-coincidence signal from inverse beta decay was inside the reactor building. Its essential elements were two independent electronic gates: one to accept pulses characteristic of the positron signal and the other to accept pulses characteristic of the neutron-capture signal. The two circuits were connected by a time-delay analyzer.

If a pulse appeared in the output of the neutron circuit within 9 microseconds of a pulse in the output of the positron circuit, the count was registered in the channel that recorded delayed coincidences. Allowing for detector efficiencies and electronic gate settings and taking into account the neutrino flux from the reactor, the expected rate for delayed coincidences from neutrino-induced events was 0.1 to 0.3 count per minute.

For several months, the team stacked and restacked the shielding and used various recipes for the liquid scintillator (see Hanford Menu in "The Hanford Experiment" collage). Then they would set the electronics and listen for the characteristic double clicks that would accompany detection of the inverse beta decay. Despite the exhausting work, the results were not definitive. The delayed-coincidence background, present whether or not the reactor was on, was about 5 counts per minute, many times higher than the expected signal rate.

The scientists guessed that the background was due to cosmic rays entering the detector, but the addition of various types of shielding left the background rate unchanged. Subsequent work underground suggested that the Hanford background of delayed-coincidence pulses was indeed due to cosmic rays. Reines and Cowan (1953) reported a small increase in the number of delayed coincidences when the reactor was on versus when it was off. Furthermore, the increase was consistent with the number expected from the estimated flux of reactor neutrinos. This was tantalizing but insufficient evidence that neutrino

events were being detected. The Hanford experience was poignantly summarized by Cowan (1964).

"The lesson of the work was clear: It is easy to shield out the noise men make, but impossible to shut out the cosmos. Neutrons and gamma rays from the reactor, which we had feared most, were stopped in our thick walls of paraffin, borax and lead, but the cosmic ray mesons penetrated gleefully, generating backgrounds in our equipment as they passed or stopped in it. We did record neutrino-like signals but the cosmic rays with their neutron secondaries generated in our shields were 10 times more abundant than were the neutrino signals. We felt we had the neutrino by the coattails, but our evidence would not stand up in court."

### The Savannah River Experiment

After the Hanford experience, the Laboratory encouraged Reines and Cowan to set up a formal group with the sole purpose of tracking neutrinos. Other than the scientists who had already been working on neutrinos, Kiko Harrison, Austin McGuire, and Herald Kruse (a graduate student at the time) were included in this group.

They spent the following year redesigning the experiment from top to bottom: detector, electronics, scintillator liquids, the whole works. The detector was entirely reconfigured to better differentiate between events induced by cosmic rays and those initiated in the detector by reactor neutrinos. Figure 4 shows the new design.

Two large, flat plastic tanks (called the "target tanks" and labeled A and B) were filled with water. The protons in the water provided the target for inverse beta decay; cadmium chloride dissolved in the water provided the cadmium nuclei that would capture the neutrons. The target tanks were sandwiched between three large scintillation detectors labeled I, II, and III (total capacity 4,200 liters), each

having 110 photomultiplier tubes to collect scintillation light and produce electronic signals.

In this sandwich configuration, a neutrino-induced event in, say, tank A would create two pairs of proton prompt-coincidence pulses from detectors I and II flanking tank A. The first pair of pulses would be from positron annihilation and the second from neutron capture. The two pairs would be separated by about 3 to 10 microseconds. Finally, no signal would emanate from detector III because the gamma rays from positron annihilation and neutron capture in tank A are too low in energy to reach detector III.

Thus, the spatial origin of the event could be deduced with certainty, and the signals would be distinguished from false delayed-coincidence signals induced by stray neutrons, gamma rays, and other stray particles from cosmic-ray showers or from the reactor. These spurious signals would most likely trigger detectors I, II, and III in a random combination. The all-important electronics were designed primarily by Kiko Harrison and Austin McGuire.

The box entitled "Delayed-Coincidence Signals from Inverse Beta Decay" (page 22) illustrates delayed-coincidence signals from the detector's top triad (composed of target tank A and scintillation detectors I and II). Once the delayed-coincidence signals have been recorded, the neutrino-induced event is complete. The signals from the positron and neutron circuits, which have been stored on delay lines, are presented to the oscilloscopes.

Figure 5 shows a few samples of oscilloscope pictures—some are acceptable signals of inverse beta decay while others are not.

Austin McGuire was in charge of the design and construction of the "tank farm" that would house and transport the thousands of gallons of liquid scintillator needed for the experiment. Three steel tanks were placed on a flat trailer bed. The interior surfaces of the tanks were coated with epoxy to preserve the purity of the liquids.

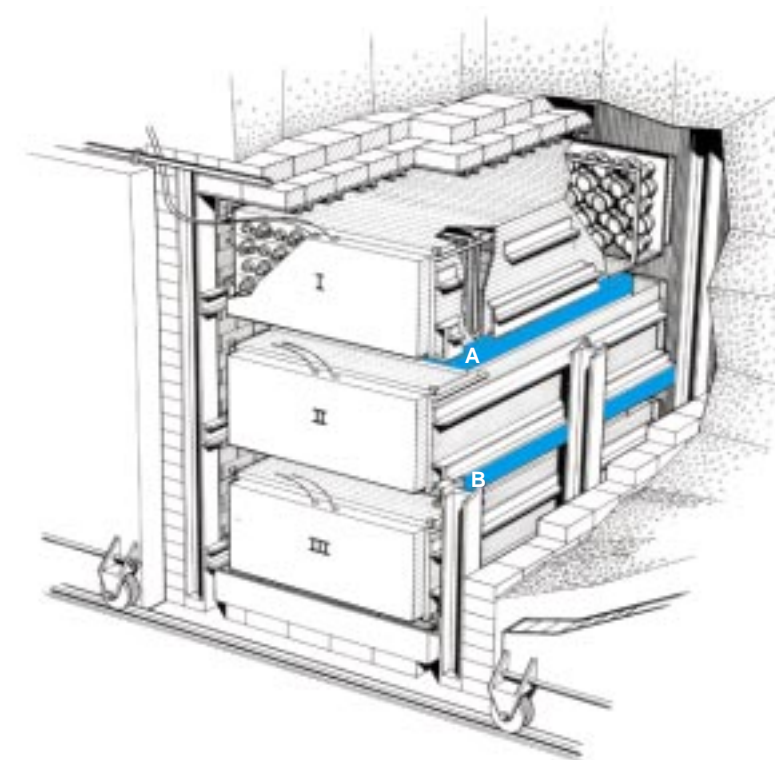

**Figure 4. The Savannah River Neutrino Detector—A New Design** The neutrino detector is illustrated here inside its lead shield. Each of two large, flat plastic tanks (pictured in light blue and labeled A and B) was filled with 200 liters of water. The protons in the water provided the target for inverse beta decay; cadmium chloride dissolved in the water provided the cadmium nuclei that would capture the neutrons. The target tanks were sandwiched between three scintillation detectors (I, II, and III). Each detector contained 1,400 liters of liquid scintillator that was viewed by 110 photomultiplier tubes. Without its shield, the assembled detector weighed about 10 tons.

Today, the need for purity and cleanliness is becoming legendary as researchers build an enormous tank for the next generation of solar-neutrino experiments (see the article "Exorcising Ghosts" on page 136), but even in the 1950s, possible background contamination was an overriding concern.

Since the scintillator had to be kept at a temperature not lower than 60 degrees Fahrenheit, the outside walls of the tanks were wrapped with several layers of fiberglass insulating material, and long strips of electrical heating elements were embedded in the exterior insulation.

During the previous winter, while the equipment was being designed and built, John Wheeler encouraged and supported the team, and he helped

pave the way for the next neutrino measurement to be done at the new, very powerful fission reactor at the Savannah River Plant in South Carolina. By November 1955, the Los Alamos group was ready and once again packed up for the long trip to the Savannah River Plant.

The only suitable place for the experiments was a small, open area in the basement of the reactor building, barely large enough to house the detector. There, 11 meters of concrete would separate the detector from the reactor core and serve as a shield from reactor-produced neutrons, and 12 meters of overburden would help eliminate the troublesome background neutrons, charged particles, and gamma rays produced by cosmic rays.



# The Savannah River Experiment

1955



a)



(b)



(e)



(f)



)

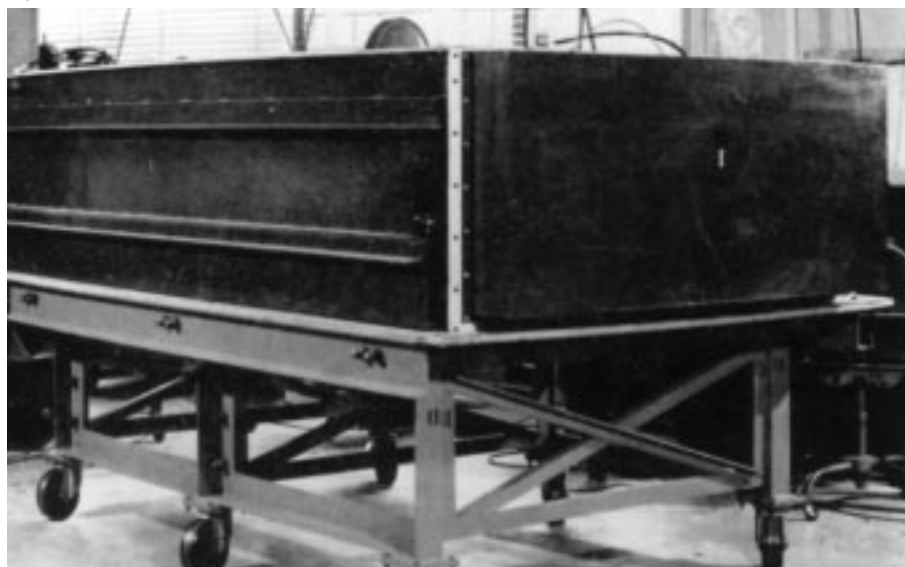

d)

After years of intense work, the members of the Los Alamos team were ready for the Savannah River experiment that would fulfill their much expected goal—the definitive detection of the neutrino.

Pictured in (a) is the tank farm, which was composed of three 4,500-liter steel tanks placed on a flat-bed trailer. The liquid scintillator was stored and shipped in those tanks. The outside walls of the tanks were wrapped with fiberglass insulation, and long electrical heating strips were embedded in the insulation to prevent the temperature inside the tanks from falling below 60 degrees Fahrenheit. Had the temperature fallen below this limit, the liquid scintillator would have turned from transparent to cloudy and would have become unusable in the experiment. (b) Fred Reines (left) and Clyde Cowan, Jr., discuss their last-minute plans for the Savannah River experiment. No detail is left uncovered. Resting in a special forklift built to handle the detector sections, one of the two target tanks filled with water and cadmium chloride is shown (c) awaiting its assembly in the detector shield. A completed detector tank (d) is ready to be inserted into the shield. This tank was made of steel plate, but its bottom was a

cellular aluminum structure that would provide not only strength against bending but also little obstruction to the entry of gamma rays from below. (e) Pictured here is the additional shielding that surrounded the detector and allowed the team to test whether the signal was coming from background neutrons and gamma rays from the reactor. This makeshift shielding, which was 4 feet thick all around the detector, consisted of bags of sawdust soaked in water for increased density (the mean density was 0.5). Its effect was to decrease the reactor-associated accidental events, whereas the signal remained constant. (f) Los Alamos team members Richard Jones (left) and Martin Warren use a forklift to insert the top target tank into the detector shield. Moving by hydraulic control, heavy lead doors (pictured behind Warren) would enclose the detector when it was on. Preamplifiers placed on a rack (pictured behind Jones) boosted the small-voltage pulses from the photomultiplier tubes and sent them through coaxial cable to the electronics housed in a truck (g) that was parked outside the reactor building.

Photos (c), (d), (e), and (f) were reprinted courtesy of Smithsonian Institution.

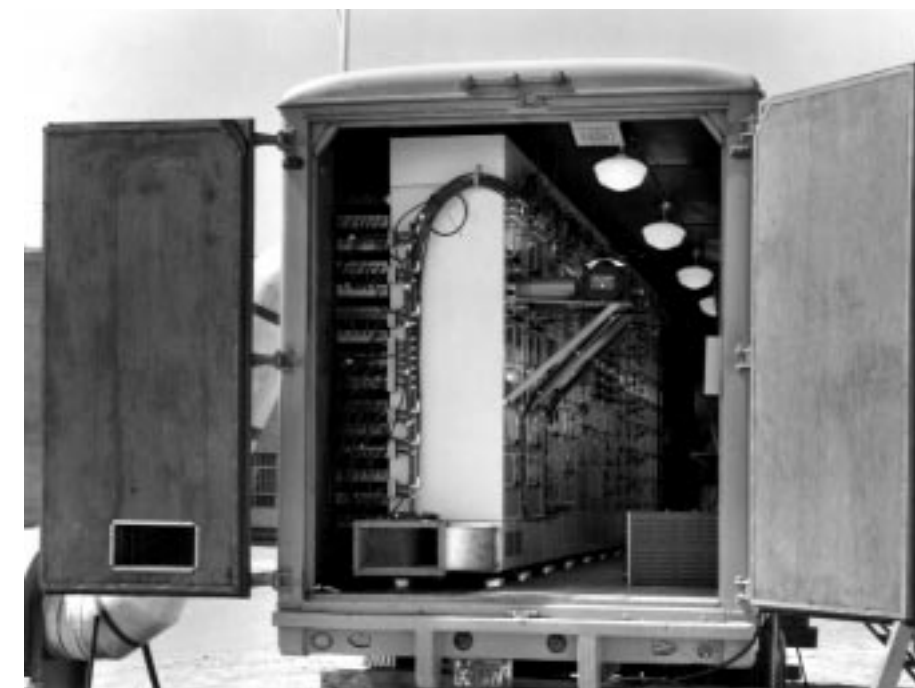

(g)

## Delayed-Coincidence Signals from Inverse Beta Decay

(a)  $T = 0$  Positron annihilation produces electron signal.

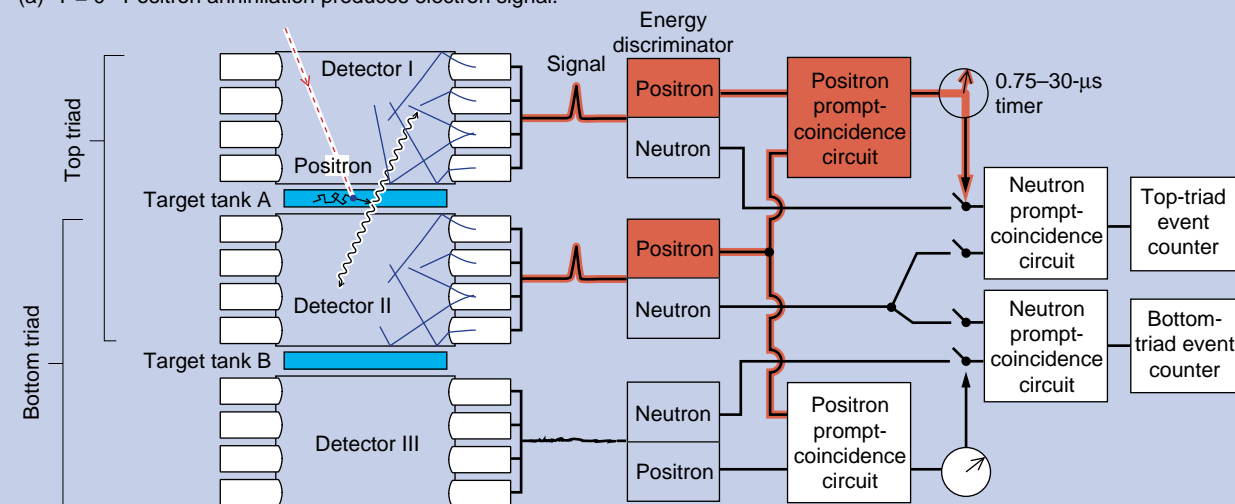

This flow diagram traces the generation of a set of delayed-coincidence signals in the top triad of the detector (target tank A and scintillation detectors I and II). An antineutrino (red dashed line) from the reactor has interacted with a proton in tank A through inverse beta decay, creating a positron and a neutron. As a result, two processes occur in tank A: positron annihilation, shown in diagram (a), and neutron capture, shown in diagram (b). In the case illustrated here, the delay between the two processes is 3 microseconds.

In diagram (a), the encounter between a positron and an electron in tank A results in two gamma rays, which go into scintillation detectors I and II, give up their energy, and produce a flash of visible light proportional to that energy. The photomultiplier tubes in each detector convert the light into an electronic signal, which is sent first to the positron signal discriminator and then to the positron prompt-coincidence circuit. The discriminator will accept the signals from detectors I and II if they are within the right energy range (between 0.2 and 0.6 MeV). The prompt-coincidence circuit will accept them if they arrive less than 0.2 microsecond apart. In this case, both conditions are fulfilled. The timer starts to tick and closes the switch to the neutron prompt-coincidence circuit for 30 microseconds, allowing signals from neutron capture to be recorded during that period.

(b)  $T = 3 \mu\text{s}$  Neutron capture produces neutron signal.

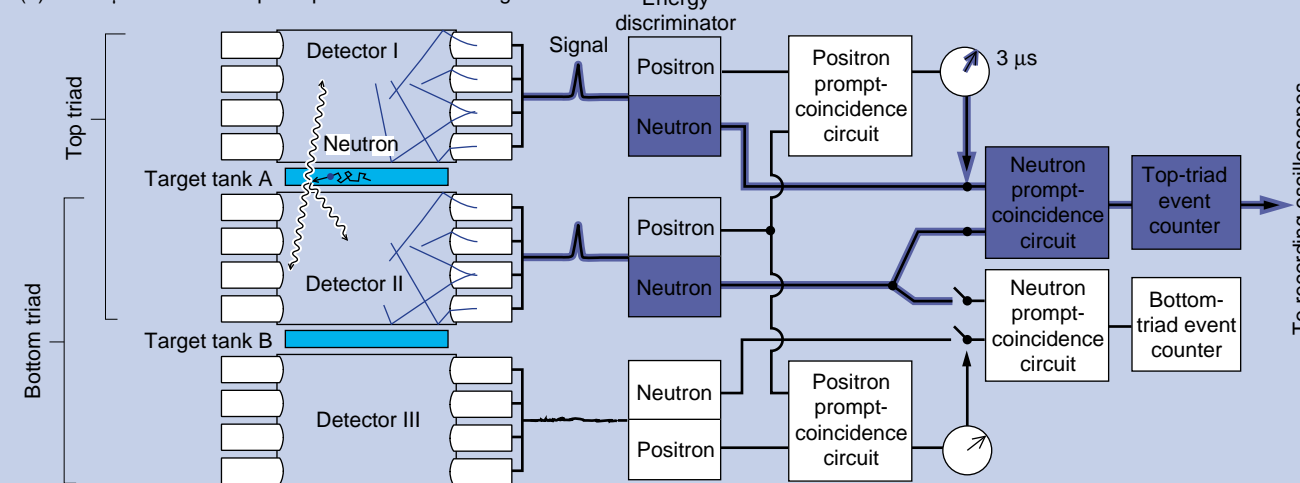

Diagram (b) pictures the slowdown of the neutron that had been generated simultaneously with the positron and its final capture by a cadmium nucleus in tank A. The excited cadmium nucleus drops to a lower energy state by emitting gamma rays, which once again create flashes of visible light in detectors I and II. The photomultiplier tubes detect that light and are shown to have produced two electronic signals whose energy is within the acceptable range, that is, the energy is greater than 0.2 MeV in each detector, with a total energy from 3 to 11 MeV (as determined by the discriminator). The signals are less than 0.2 microsecond apart in reaching the neutron prompt-coincidence circuit. Thus, they are accepted as a true signal of neutron capture. At this point, the timer has advanced to

3 microseconds, indicating the delay between the two processes. The delayed-coincidence signals caused by the neutrino-induced inverse beta decay is now complete. A scaler is automatically activated, the recording oscilloscopes are triggered to sweep across the cathode-ray screens, and the signals from the positron and neutron circuits, which have been stored on delay lines, are presented to the oscilloscopes.

he very large detector—over 2 meters high and weighing about 10 tons—had to be installed in those cramped underground quarters.

There was just enough room left for several preamplifiers (needed to boost the small signals from the photomultipliers) to be set on a rack near the detector, but the electronics had to be housed outside, in a trailer. The tank arm containing the precious liquid scintillator was also parked outside. The Los Alamos group used a whole network of stainless-steel pipes and valves, along with special pumps, to mix the solutions and pump them from the holding tanks in the parking lot into the detector down

in the basement.

The team members stayed in Savannah River for over five months. They took data for about 900 hours when the reactor was on and for about 250 hours when it was off. Their immediate goal was to demonstrate a neutrino-like signal that was much larger when the reactor was on than off, indicating that it was caused by the flux of antineutrinos coming from the reactor.

In fact, the rate of delayed coincidences of the type described above was 5 times greater when the reactor was on than off and corresponded to about one reactor-associated event per hour. There was also the question of whether the delayed coincidences were accidental,

that is, caused by an accidental correlation between gamma rays and neutrons from the reactor. The neutron-capture delay time was unlikely to be more than 10 microseconds, whereas data were taken for up to 30 microseconds.

Thus, the accidental background rate could be estimated as the rate of delayed coincidences that occurred with neutron-capture delay times between 11 and 30 microseconds. Using this estimate, the team derived the rate of signal to accidental background events to have been 4 to 1.

Although the delayed-coincidence signal is a telltale signature of inverse beta decay, the Los Alamos team members took nothing for granted.

They tested their measured signal extensively to ensure that it was indeed due to the products of neutrino-induced inverse beta decay, in particular that

- the first and second prompt-coincidence pulses were generated by positron annihilation and neutron capture, respectively, rather than other processes,
- the signal was proportional to the number of target protons, and
- the signal was not due to neutrons and gamma rays from the reactor.

For example, to check the positron signal, the Los Alamos researchers compared the pair of prompt-coincidence pulses making up the positron signal with those produced

during a test run by a positron source (copper-64) dissolved in the water. To check the neutron capture signal, they doubled the amount of cadmium in the water to see if the average time delay between the positron-annihilation and neutron-capture signals decreased, as expected if the second signal was truly due to neutron capture.

To test that the signal was proportional to the number of target protons, they reduced the number of protons to half the original value by filling the tank with an equal mixture of heavy water ( $D_2O$ ) and ordinary water. They then looked for a decrease in the signal corresponding to the decrease in the cross section for inverse beta decay on

deuterium versus the cross section for inverse beta decay on hydrogen.

Finally, to test whether the signal was coming from background neutrons and gamma rays from the reactor, they surrounded the detector with additional makeshift shielding. Bags of sawdust donated by a local sawmill and soaked in water for increased density were a cheap and flexible solution to the problem of creating an additional shield. Their effect was to decrease the reactor-associated accidental events, whereas the signal stayed constant. This and all other tests confirmed that the signal was indeed due to reactor antineutrinos being captured by protons in the water tanks of the detector and inducing inverse beta decays.



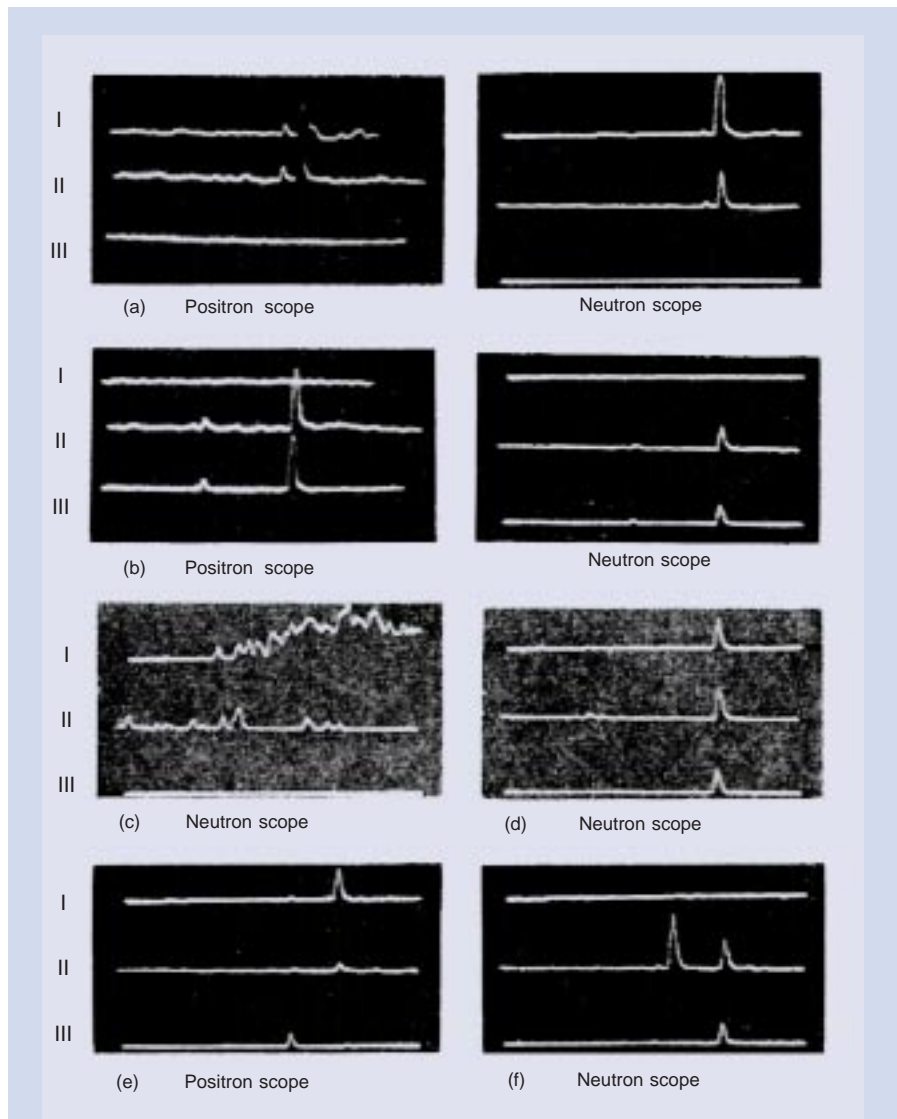

**Figure 5. Oscilloscope Traces from the Savannah River Experiments**  
 In these oscilloscope pictures, traces from detectors I, II, and III are labeled I, II, and III, respectively. The label under each frame indicates whether the signals were recorded by the scope for positron annihilation or the scope for neutron capture. Acceptable delayed-coincidence signals are shown in (a) and (b), while rejected signals are pictured in (c) through (f).

(a) The delayed-coincidence signal in these two frames has occurred in the top triad of the detector because the pulses appeared in detectors I and II. **Positron scope:** The pulse energies in detectors I and II were 0.30 MeV and 0.35 MeV, respectively. The pulses reached the positron circuit in prompt coincidence (less than 0.2 microsecond apart) and were accepted as a signal of positron annihilation. **Neutron scope:** The pulse energies in detectors I and II were 5.8 MeV and 3.3 MeV, respectively. These pulses arrived in prompt coincidence and were accepted as a signal of neutron capture. The delay between the positron and neutron signals was 2.5 microseconds. (b) The delayed-coincidence signal in these two frames has occurred in the bottom triad because the pulses appeared in detectors II and III. **Positron scope:** The pulse energies in detectors II and III were 0.25 MeV and 0.30 MeV, respectively.

**Neutron scope:** The pulse energies in detectors II and III were 2.0 MeV and 1.7 MeV, respectively. The delay between the positron and neutron signals was 13.5 microseconds. (c) The pulses from the neutron circuit were the result of electrical noise. (d) These three pulses from the neutron circuit were caused by a cosmic-ray event. (e) These three pulses from the positron circuit were caused by cosmic-ray event. (f) These pulses may have been caused by a cosmic-ray event. They were rejected as a signal of neutron capture because of the extra pulse from detector II. Frames like this one occurred more often than would be expected from chance coincidences. They were, however, not often enough to affect the results considerably. These data appeared in Reines, Cowan, Harrison, et al. 1960.

### Announcement of Results

On June 14, 1956, after all the tests had been completed, Reines and Cowan sent a telegram to Pauli at Zürich University:

“We are happy to inform you that we have definitely detected neutrinos from fission fragments by observing inverse beta decay of protons. Observed cross section agrees well

with expected six times ten to minus forty-four square centimeters.”

In his 1979 article in *Science* about the early days of experimental neutrino physics, Reines describes Pauli’s reaction to the news:

“The message was forwarded to him [Pauli] at CERN, where he interrupted the meeting he was attending to read the telegram to the conferees and then made some impromptu remarks regard-

ing the discovery. We learned later that Pauli and some friends consumed a case of champagne in celebration.”

Although the intent of the Savannah River experiment was to get a positive signal of neutrino detection, the experiment also yielded a measurement of the rate, or more exactly the cross section, for inverse beta decay. (The cross section for the neutrino to be captured by a proton can be thought of as the effective

target area that a proton presents to a neutrino. The larger the area, the more likely it is that the process will occur.)

The measured rate, or the number of events per second, depends on (1) the rate at which neutrinos are entering the target area (the neutrino flux was approximately 1,013 neutrinos per square centimeter per second), (2) the number of target protons in the water tank (approximately 1,028 target protons), (3) the cross section for the reaction, and (4) the efficiency of the detectors in picking up positron and neutron signals from the reaction.

According to Fermi’s theory, the cross section for inverse beta decay varies with energy. Given the energy spectrum of the reactor-produced antineutrinos (the average energy was 3 MeV), the theoretically predicted cross section for inverse beta decay on protons is  $6.3 \times 10^{-44}$ , with an uncertainty of about 25 percent arising from the uncertainty of the energy spectrum for the reactor neutrinos. The violation of parity conservation (namely, the symmetry between left-handedness and right-handedness) by the weak force had not yet been discovered, and so this theoretical value was based on the parity-conserving formulation of Fermi’s theory of beta decay in which the neutrino, like the electron, has four independent degrees of freedom.

In July 1956, a brief article in *Science* by Reines, Cowan, Harrison, McGuire, and Kruse announced that the Savannah River experiment had confirmed the tentative findings of the Hanford experiment. The authors also stated that their results were in agreement within 5 percent of the theoretically predicted value for the inverse-beta-decay cross section. Such results were fortuitous given the uncertainties in the neutrino flux and in the detector efficiency.

A more detailed paper on this experiment published in *Physical Review* in 1960 reported a cross section twice as large as that reported in 1956. According to Reines (1979), the increase in the value occurred because “our initial

analysis grossly overestimated the detection efficiency with the result that the measured cross section was at first thought to be in good agreement with [the pre-parity violation] prediction.”

The theoretical cross section had also doubled between 1956 and 1960 because of the discovery in 1957 of parity nonconservation in the weak interactions and the formulation of the two-component theory of the neutrino (see the box “Parity Nonconservation and the Massless Two-Component Neutrino” on page 32). So, the measured cross section reported in the literature remained in agreement with the theoretical prediction.

In addition, after the 1956 experiment, Reines and Cowan did another measurement with a new setup and, in a 1959 *Physical Review* paper, reported results for the cross section that were in agreement with the two-component neutrino, parity-nonconserving theory.

Over the years, there has been some skepticism about the differing published values. These feelings may have been responsible for the forty years that had passed before the discovery of the neutrino was recognized with the Nobel Prize. Nevertheless, the award is a clear recognition that the Savannah River experiment was an extraordinary accomplishment. Reines wished that Cowan had been alive to share the prestigious award with him. The elusive product of the weak force that can penetrate the earth and travel to the ends of the universe was finally observed stopping in its tracks. The neutrino became a tangible reality, and the experiment itself set a precedent for using the neutrino as an experimental tool.

Indeed, since the Reines-Cowan experiments, neutrino detection has produced some dramatic results. One was the 1963 experiment of Lederman, Schwartz, and Steinberger proving that a second (muon) neutrino was paired with the muon in the way the known (electron) neutrino was paired with the electron. That result not only earned the discoverers the Nobel Prize, but also

established the first hint of the second family of elementary particles (all three families are introduced in the primer, “The Oscillating Neutrino,” on page 28).

Another was the detection of a burst of neutrinos from supernova 1987A (SN1987A)—twenty hits within 12 seconds in two enormous detectors located on opposite sides of the planet, both buried deep underground where one expects to see only one neutrino event per day. It was the unmistakable signature of an exploding star, and it provided extraordinary confirmation of the exotic notion that neutrinos, the most standoffish members of the pantheon of elementary particles, could drive the largest explosion ever witnessed by human beings.

And at present, neutrino data are accumulating from even more-modern neutrino detectors, some buried deep underground, some poised at accelerators, some awaiting completion, all dedicated to seeing whether the neutrinos, long purported to be massless particles, not only carry mass but also oscillate from one identity to another as they fly freely through space.

The world of physics owes much to Fred Reines for these developments. His single-minded dedication to the neutrino set an example, not only in the 1950s but throughout his career. And his courage to “think big” continued well after his tenure at Los Alamos. Reines was one of the critical cospokespersons for the construction of the huge IMB detector, a water-filled, 8,000-ton Cerenkov detector located in the Morton salt mine near Cleveland, Ohio. It was there that half of the events from SN1987A were detected and many of the data on the oscillation of atmospheric neutrinos were gathered.

Through this volume, Los Alamos National Laboratory takes pride in the accomplishments of Fred Reines, Clyde Cowan, Jr., and the teams of Laboratory workers who performed to the best of their ability in demonstrating the existence of the neutrino. And Fred Reines, in his gracious way,

as openly thanked the Laboratory: “Looking back, we had much to be thankful for. We had indeed been in the right place at the right time. The unlikely trail from bombs to detection of the free neutrino could, in my view, only have happened at Los Alamos.” (Reines 1982) ■

### Further Reading

Reines, H. A., and R. F. Bacher. 1936. Disintegration and Nuclear Forces. *Review of Modern Physics* 8 (82): 184.

Cowan, C. L. 1964. Anatomy of an Experiment: An Account of the Discovery of the Neutrino. *Smithsonian Institution Annual Report*: 409.

Cowan, C. L., Jr., F. Reines, F. B. Harrison, E. C. Anderson, and F. N. Hayes. 1953. Large Liquid Scintillation Detectors. *Physical Review* 90 (3): 493.

Cowan, C. L., Jr., F. Reines, F. B. Harrison, H. W. Kruse, and A. D. McGuire. 1956. Detection of the Free Neutrino: A Confirmation. *Science* 124 (3212): 103.

Reines, H. R. 1948. The Energy and Momentum Relations in the Beta-Decay, and the Search for the Neutrino. 1948. *Reviews of Modern Physics* 20 (1): 278.

Reines, F. 1979. The Early Days of Experimental Neutrino Physics. *Science* 203 (4375): 11.

———. 1982. Neutrinos to 1960—Personal Recollections. *Journal de Physique* 43 (supplement to 12): C8-237.

Reines, F., and C. L. Cowan, Jr., 1953. Detection of the Free Neutrino. *Physical Review Letters* 92: 330.

———. 1959. Free Antineutrino Absorption Cross Section. I. Measurement of the Free Antineutrino Absorption Cross Section by Protons. *Physical Review* 113 (1): 273.

Reines, F., C. L. Cowan, Jr., F. B. Harrison, A. D. McGuire, and H. W. Kruse. 1960. Detection of the Free Antineutrino. *Physical Review* 117 (1): 159.

Reynolds, G. T., F. B. Harrison, and G. Salvini. 1950. Liquid Scintillation Counters. *Physical Review* 78 (4): 488.

Reines, F., and C. L. Cowan, Jr. 1992. *Spaceship Neutrino*. New York: Cambridge University Press.

**Frederick Reines** is best known for his discovery of the nearly massless elementary particle, the neutrino. For this work, he was awarded the Nobel Prize in physics in 1956. Collaborating with Clyde Cowan, Jr., Reines determined conclusively the existence of the neutrino during experiments conducted at the Savannah River Plant in 1956. Subsequently, Reines devoted his career to investigating the properties and interactions of the neutrino as it relates not only to elementary particle physics but also to astrophysics.

This lifelong research produced a number of fundamental “firsts” credited to Reines. One of the most recent achievements, the codiscovery of neutrinos emitted from supernova 1987A (SN1987A), demonstrated the theorized role of the neutrino in stellar collapse. Reines captured the difficulty of this work vividly: “It’s like listening for a gnat’s whisper in a hurricane.”

Significant other firsts include detecting neutrinos produced in the atmosphere, studying muons induced by neutrino interactions underground, observing the scattering of electron antineutrinos with electrons, detecting weak neutral-current interactions of electron antineutrinos with deuterons, and searching for neutrino oscillations (the possibility of neutrino transformation from one type to another). In addition, Reines and his coworkers have pursued for nearly forty years a program of experiments to test some of the fundamental conservation laws of nature, including conservation of lepton number (which would be violated in the decay of an electron or neutrino or in the change of lepton type) and conservation of baryon number, which would be manifested in the decay of the proton, as predicted by the Grand Unified Theories of elementary particles.

Reines was born in Paterson, New Jersey, on March 16, 1918. He earned his M.E. in mechanical engineering in 1939 and his M.A. in science in 1941 from Stevens Institute

**Clyde L. Cowan, Jr.**, was born in Detroit, Michigan, on December 6, 1919. He earned his B.S. in chemical engineering at the Missouri School of Mines and Metallurgy (later to become part of the University of Missouri) in 1940 and his M.S. and Ph.D. in physics from Washington University in St. Louis, Missouri, in 1947 and 1949, respectively.

During the Second World War, Cowan joined the U.S. Army Chemical Warfare Service as a 2nd lieutenant and shortly thereafter left for England with the 51st Troop Carrier Wing. While he was stationed in England, Cowan was involved in making changes to the newly developed radar. For this significant work, he was later awarded the Bronze Star.

Soon after the war, Cowan returned to the United States where he was accepted as the first physics graduate student to Washington University. His thesis was an in-depth study of the absorption of gamma radiation. Soon after graduate school, Cowan realized that Los Alamos was the logical place for him to work, and in 1949 he joined the Laboratory as a staff member. Only two years later, Cowan became group leader of the Nuclear Weapons Test Division at Los Alamos.

In 1951, Cowan began a historic collaboration with Fred Reines. Its outcome was the successful detection of the neutrino during an experiment conducted at the Savannah River Plant in 1956. After this discovery, neutrino physics became seminal

of Technology in Hoboken, New Jersey. He received his Ph.D. in theoretical physics from New York University in 1944. That same year, he joined the Los Alamos Scientific Laboratory as a staff member, later to become group leader in the Theoretical Division, and was tasked to study the blast effects of nuclear weapons. In 1959, Reines became head of the Physics Department at Case Institute of Technology. At the same time, he served as consultant to Los Alamos and the Institute for Defense Analysis, as well as trustee of the Argonne National Laboratory. In 1966, however, Reines accepted a dual appointment as the first dean of physical sciences and physics professor at the University of California, Irvine. Four years later, he was appointed professor of radiological sciences at Irvine’s Medical School. When Reines retired in 1988, he was Distinguished Emeritus Professor of Physics at Irvine.

For his outstanding work in elementary particle physics, Reines has received numerous honors and major awards. In 1957, he became fellow of the American Physical Society; in 1958, Guggenheim fellow; in 1959 Alfred P. Sloan fellow; in 1979, fellow of the American Association for the Advancement of Science; and in 1980, member of the National Academy of Sciences. In 1981, Reines received the J. Robert Oppenheimer Memorial Prize. He was presented the National Medal of Science by President Ronald Reagan in 1983, the Bruno Rossi Prize in 1989, the Michelson-Morley Award in 1990, the W. K. H. Panofsky Prize and the Franklyn Medal in 1992. He is a member of the American Academy of Arts and Sciences.

During a 1985 interview with *The New York Times*, Reines labored when he was asked to describe the significance of his discovery of the neutrino: “I don’t say that the neutrino is going to be a practical thing, but it has been a time-honored pattern that science leads, and then technology comes along, and then, put together, these things make an enormous difference in how we live.” And now, more than forty years after the discovery of the neutrino, Reines’ scientific peers believe that this discovery made Reines a giant in his field.

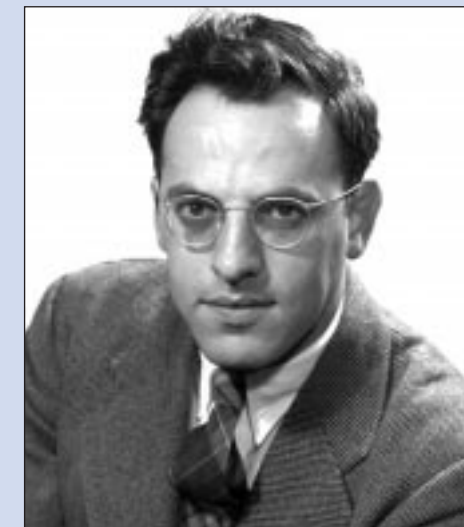

to worldwide studies of the weak force. In 1957, Cowan was awarded a Guggenheim fellowship to study the physics of the neutrino and its interactions with atomic nuclei.

Cowan’s creativity has been a mark of his scientific career from the early and fruitful years in Los Alamos to the successful teaching years at the Catholic University of America, where he was a physics professor from 1958 until his untimely death in 1974. Upon his suggestion, the bubble chamber became a tool for studying neutrino interactions. Cowan was one of the first physicists who used large scintillation counters for particle detection, an important technique in elementary particle physics. His collaboration with Reines led to the development of the whole-body counter, which measured low levels of naturally occurring radiation in humans. Having witnessed about thirty nuclear explosions while he was in the Nuclear Weapons Test Division at Los Alamos, Cowan was among the first to have studied the electromagnetic signal produced by a nuclear explosion.

Throughout his career, Cowan served as a consultant to the United States Naval Academy, the U.S. Atomic Energy Commission, the Naval Ordnance, and the Smithsonian Institution, where he helped create the permanent Hall of Nuclear Energy. Cowan was a fellow of the American Physical Society and the American Association for the Advancement of Science. He was a member of numerous scientific and civic organizations. Having dedicated his life to scientific investigation, Cowan has been a source of inspiration to generations of young, aspiring scientists.

