



CAGE Code 81205

767 Airplane Characteristics for Airport Planning

DOCUMENT NUMBER:

D6-58328

REVISION:

REV I

REVISION DATE:

July 2021

CONTENT OWNER:

Boeing Commercial Airplanes

All revisions to this document must be approved by the content owner before release.

Not Subject to US Export Administration Regulations (EAR), (15 C.F.R. Parts 730-774) or US International Traffic in Arms Regulations (ITAR), (22 C.F.R. Parts 120-130).



Revision Record

Revision Letter **A**

Revision Date **July 1980**

**Changes in This
Revision**

Revision Letter **B**

Revision Date **July 1981**

**Changes in This
Revision**

Revision Letter **C**

Revision Date **April 1983**

**Changes in This
Revision**

Revision Letter **D**

Revision Date **December 1983**

**Changes in This
Revision**

Revision Letter **E**

Revision Date **January 1986**

**Changes in This
Revision**

Revision Letter **F**

Revision Date **February 1989**

**Changes in This
Revision**

Revision Letter **G**

Revision Date **December 2003**

**Changes in This
Revision**

Revision Letter **H**

Revision Date **September 2005**

**Changes in This
Revision** All

Revision Letter **I**

Revision Date **July 2021**

**Changes in This
Revision** Entire document converted to new format
Consolidation of aircraft model weights in Sections 2 and 7
Section 5 Servicing Arrangements
Section 7 Information Updates

D6-58328

Table of Contents

1.0	SCOPE AND INTRODUCTION	1-1
1.1	SCOPE	1-1
1.2	INTRODUCTION	1-2
1.3	A BRIEF DESCRIPTION OF THE 767	1-3
1.3.1	Brief Description – Engine/Weight Combinations: 767	1-5
2.0	AIRPLANE DESCRIPTION.....	2-1
2.1	GENERAL CHARACTERISTICS	2-1
2.1.1	General Characteristics: Model 767-200	2-2
2.1.2	General Characteristics: Model 767-200ER	2-3
2.1.3	General Characteristics: Model 767-300	2-4
2.1.4	General Characteristics: Model 767-300ER	2-5
2.1.5	General Characteristics: Model 767-300 Freighter.....	2-6
2.1.6	General Characteristics: Model 767-400ER	2-7
2.2	GENERAL DIMENSIONS	2-8
2.2.1	General Dimensions: Model 767-200, -200ER.....	2-8
2.2.2	General Dimensions: Model 767-300, -300ER.....	2-9
2.2.3	General Dimensions: Model 767-300 Freighter	2-10
2.2.4	General Dimensions: Model 767-400ER.....	2-11
2.3	GROUND CLEARANCES	2-12
2.3.1	Ground Clearances: Model 767-200, -200ER.....	2-12
2.3.2	Ground Clearances: Model 767-300, -300ER.....	2-13
2.3.3	Ground Clearances: Model 767-300 Freighter	2-14
2.3.4	Ground Clearances: Model 767-400ER.....	2-15
2.4	INTERIOR ARRANGEMENTS.....	2-16
2.4.1	Typical Interior Arrangements: Model 767-200, -200ER, Mixed Class	2-16
2.4.2	Typical Interior Arrangements: Model 767-200, -200ER, All- Economy Class.....	2-17
2.4.3	Typical Interior Arrangements: Model 767-300, -300ER, Mixed Class	2-18
2.4.4	Typical Interior Arrangements: Model 767-300, -300ER, Mixed Class, Type A Door Option.....	2-19
2.4.5	Typical Interior Arrangements: Model 767-300, -300ER, All- Economy Class.....	2-20
2.4.6	Typical Interior Arrangements: Model 767-300 Freighter, Main Deck Cargo.....	2-21
2.4.7	Typical Interior Arrangements: Model 767-400ER.....	2-22
2.5	CABIN CROSS SECTIONS	2-23

2.5.1	Cabin Cross-Sections: Model 767-200, -200ER, -300, -300ER, -400ER, Economy Class.....	2-23
2.5.2	Cabin Cross-Sections: Model 767-200, -200ER, -300, -300ER, -400ER, Alternate Seating.....	2-24
2.6	LOWER CARGO COMPARTMENTS	2-25
2.6.1	Lower Cargo Compartments: Model 767-200, -200ER, LD-2 Containers and Bulk Cargo	2-25
2.6.2	Lower Cargo Compartments: Model 767-200, -200ER, Alternate.....	2-26
2.6.3	Lower Cargo Compartments: Model 767-300, -300ER, -300 Freighter, LD-2 Containers and Bulk Cargo.....	2-27
2.6.4	Lower Cargo Compartments: Model 767-300, -300ER, -300 Freighter, LD-2 Containers and Bulk Cargo.....	2-28
2.6.5	Lower Cargo Compartments: Model 767-400ER, Containers and Bulk Cargo	2-29
2.7	DOOR CLEARANCES.....	2-30
2.7.1	Door Clearances: Model 767-200, -200ER, -300, -300ER, -300 Freighter, -400ER, Passenger and Service Doors	2-30
2.7.2	Door Clearances: Model 767-200, -200ER, -300, -300ER, -300 Freighter, -400ER, Locations of Probes and Sensors Near Main Entry Door No. 1	2-31
2.7.3	Door Clearances: Model 767-200, -200ER, -300, -300ER, Standard Forward Cargo Door	2-32
2.7.4	Door Clearances: Model 767-200, -200ER, -300, -300ER, -300 Freighter, -400ER, Large Forward Cargo Door.....	2-33
2.7.5	Door Clearances: Model 767-200, -200ER, -300, -300ER, -300 Freighter, -400ER, Aft Cargo Door	2-34
2.7.6	Door Clearances: Model 767-200, -200ER, -300, -300ER, -300 Freighter, -400ER, Bulk Cargo Door.....	2-35
2.7.7	Door Clearances: Model 767-300 Freighter, Main Deck Cargo Door.....	2-36
3.0	AIRPLANE PERFORMANCE	3-1
3.1	GENERAL INFORMATION.....	3-1
3.2	PAYLOAD/RANGE	3-2
3.2.1	Payload/Range: Model 767-200, Long-Range Cruise	3-2
3.2.2	Payload/Range: Model 767-200ER, Long-Range Cruise	3-3
3.2.3	Payload/Range: Model 767-300, Long-Range Cruise	3-4
3.2.4	Payload/Range: Model 767-300ER, -300 Freighter, Long-Range Cruise	3-5
3.2.5	Payload/Range: Model 767-300ER, Long-Range Cruise, (CF6-80C2B7F1 Engines).....	3-6
3.2.6	Payload/Range: Model 767-300ER, Long-Range Cruise, (PW4062 Engines)	3-7

3.2.7	Payload/Range: Model 767-300 Freighter, Long-Range Cruise, (CF6-80C2B7F1 Engines)	3-8
3.2.8	Payload/Range: Model 767-300 Freighter, Long-Range Cruise, (PW4062 Engines)	3-9
3.2.9	Payload/Range: Model 767-400ER, Long-Range Cruise, (CF6-80C2B8 Engines)	3-10
3.2.10	Payload/Range: Model 767-400ER, Long-Range Cruise, (PW4062 Engines)	3-11
3.3	FAA/EASA TAKEOFF RUNWAY LENGTH REQUIREMENTS	3-12
3.3.1	FAA/EASA Takeoff Runway Length Requirements - Standard Day: Model 767-200, -200ER (JT9D-7R4D/7R4E, CF6-80A/80A2 Engines).....	3-12
3.3.2	FAA/EASA Takeoff Runway Length Requirements - Standard Day + 31°F (STD + 17°C): Model 767-200, -200ER (JT9D-7R4D/7R4E, CF6-80A/80A2 Engines).....	3-13
3.3.3	FAA/EASA Takeoff Runway Length Requirements - Standard Day: Model 767-200, -200ER (CF6-80C2B2, PW4052 Engines).....	3-14
3.3.4	FAA/EASA Takeoff Runway Length Requirements - Standard Day + 31°F (STD + 17°C): Model 767-200, -200ER (CF6-80C2B2, PW4052 Engines)	3-15
3.3.5	FAA/EASA Takeoff Runway Length Requirements - Standard Day: Model 767-200ER (CF6-80C2B4, PW4056, RB211-524G Engines).....	3-16
3.3.6	FAA/EASA Takeoff Runway Length Requirements - Standard Day + 31°F (STD + 17°C): Model 767-200ER (CF6-80C2B4, PW4056, RB211-524G Engines)	3-17
3.3.7	FAA/EASA Takeoff Runway Length Requirements - Standard Day: Model 767-300 (CF6-80A/80A2 Engines).....	3-18
3.3.8	FAA/EASA Takeoff Runway Length Requirements - Standard Day + 33°F (STD + 18°C): Model 767-300 (CF6-80A/80A2 Engines).....	3-19
3.3.9	FAA/EASA Takeoff Runway Length Requirements - Standard Day: Model 767-300 (JT9D-7R4D/7R4E Engines).....	3-20
3.3.10	FAA/EASA Takeoff Runway Length Requirements - Standard Day + 27°F (STD + 15°C): Model 767-300 (JT9D-7R4D/7R4E Engines).....	3-21
3.3.11	FAA/EASA Takeoff Runway Length Requirements - Standard Day: Model 767-300 (CF6-80C2B2, PW4052 Engines)	3-22
3.3.12	FAA/EASA Takeoff Runway Length Requirements - Standard Day + 31°F (STD + 17°C): Model 767-300 (CF6-80C2B2, PW4052 Engines).....	3-23
3.3.13	FAA/EASA Takeoff Runway Length Requirements – Standard Day: Model 767-300ER, -300 Freighter (CF6-80C2B4, PW4056, RB211-524G Engines).....	3-24

3.3.14	FAA/EASA Takeoff Runway Length Requirements - Standard Day + 31°F (STD + 17°C): Model 767-300ER, -300 Freighter (CF6-80C2B4, PW4052, RB211-524G Engines)	3-25
3.3.15	FAA/EASA Takeoff Runway Length Requirements – Standard Day: Model 767-300ER, -300 Freighter (CF6-80C2B64, PW4060, RB211-524H Engines)	3-26
3.3.16	FAA/EASA Takeoff Runway Length Requirements - Standard Day + 27°F (STD + 15°C): Model 767-300ER, -300 Freighter (CF6-80C2B6, PW4060, RB211-524H Engines)	3-27
3.3.17	FAA/EASA Takeoff Runway Length Requirements - Standard Day: Model 767-300ER (CF6-80C2B7F Engines).....	3-28
3.3.18	FAA/EASA Takeoff Runway Length Requirements - Standard Day + 27°F (STD + 15°C): Model 767-300ER (CF6-80C2B7F Engines).....	3-29
3.3.19	FAA/EASA Takeoff Runway Length Requirements - Standard Day: Model 767-300ER (PW4062 Engines).....	3-30
3.3.20	FAA/EASA Takeoff Runway Length Requirements - Standard Day + 27°F (STD + 15°C): Model 767-300ER (PW4062 Engines)....	3-31
3.3.21	FAA/EASA Takeoff Runway Length Requirements - Standard Day: Model 767-300 Freighter (CF6-80C2B7F Engines)	3-32
3.3.22	FAA/EASA Takeoff Runway Length Requirements - Standard Day + 27°F (STD + 15°C): Model 767-300 Freighter, (CF6-80C2B7F Engines)	3-33
3.3.23	FAA/EASA Takeoff Runway Length Requirements - Standard Day: Model 767-300 Freighter (PW4062 Engines)	3-34
3.3.24	FAA/EASA Takeoff Runway Length Requirements - Standard Day + 27°F (STD + 15°C): Model 767-300 Freighter (PW4062 Engines).....	3-35
3.3.25	FAA/EASA Takeoff Runway Length Requirements - Standard Day, Dry Runway Surface: Model 767-400ER (CF6-80C2B8F Engines).....	3-36
3.3.26	FAA/EASA Takeoff Runway Length Requirements - Standard Day + 31°F (STD + 17°C), Dry Runway Surface: Model 767-400ER (CF6-80C2B8F Engines)	3-37
3.3.27	FAA/EASA Takeoff Runway Length Requirements - Standard Day, Wet Smooth Runway Surface: Model 767-400ER (CF6-80C2B8F Engines)	3-38
3.3.28	FAA/EASA Takeoff Runway Length Requirements - Standard Day + 27°F (STD + 15°C), Wet Smooth Runway Surface: Model 767-400ER (CF6-80C2B8F Engines)	3-39
3.3.29	FAA/EASA Takeoff Runway Length Requirements - Standard Day, Dry Runway Surface: Model 767-400ER (CF6-80C2B7F1 Engines).....	3-40

3.3.30	FAA/EASA Takeoff Runway Length Requirements - Standard Day + 27°F (STD + 15°C), Dry Runway Surface: Model 767-400ER (CF6-80C2B7F1 Engines)	3-41
3.3.31	FAA/EASA Takeoff Runway Length Requirements - Standard Day, Wet Smooth Runway Surface: Model 767-400ER (CF6-80C2B7F1 Engines)	3-42
3.3.32	FAA/EASA Takeoff Runway Length Requirements - Standard Day + 27°F (STD + 15°C), Wet Smooth Runway Surface: Model 767-400ER (CF6-80C2B7F1 Engines)	3-43
3.3.33	FAA/EASA Takeoff Runway Length Requirements - Standard Day, Dry Runway Surface: Model 767-400ER (PW4062 Engines)....	3-44
3.3.34	FAA/EASA Takeoff Runway Length Requirements - Standard Day + 27°F (STD + 15°C), Dry Runway Surface: Model 767-400ER (PW4062 Engines)	3-45
3.3.35	FAA/EASA Takeoff Runway Length Requirements - Standard Day, Wet Smooth Runway Surface: Model 767-400ER (PW4062 Engines).....	3-46
3.3.36	FAA/EASA Takeoff Runway Length Requirements - Standard Day + 27°F (STD + 15°C), Wet Smooth Runway Surface: Model 767-400ER (PW4062 Engines).....	3-47
3.4	FAA/EASA LANDING RUNWAY LENGTH REQUIREMENTS.....	3-48
3.4.1	FAA Landing Runway Length Requirements – Flaps 25: Model 767-200, -200ER	3-48
3.4.2	FAA/EASA Landing Runway Length Requirements – Flaps 30: Model 767-200, -200ER.....	3-49
3.4.3	FAA/EASA Landing Runway Length Requirements – Flaps 25: Model 767-300	3-50
3.4.4	FAA/EASA Landing Runway Length Requirements – Flaps 30: Model 767-300	3-51
3.4.5	FAA/EASA Landing Runway Length Requirements – Flaps 25: Model 767-300ER.....	3-52
3.4.6	FAA/EASA Landing Runway Length Requirements – Flaps 30: Model 767-300ER.....	3-53
3.4.7	FAA/EASA Landing Runway Length Requirements – Flaps 25: Model 767-300 Freighter	3-54
3.4.8	FAA/EASA Landing Runway Length Requirements – Flaps 30: Model 767-300 Freighter	3-55
3.4.9	FAA/EASA Landing Runway Length Requirements – Flaps 25: Model 767-400ER.....	3-56
3.4.10	FAA/EASA Landing Runway Length Requirements – Flaps 30: Model 767-400ER.....	3-57
4.0	GROUND MANEUVERING	4-1
4.1	GENERAL INFORMATION.....	4-1

4.2	TURNING RADII	4-2
4.2.1	Turning Radii – No Slip Angle: Model 767-200, -200ER.....	4-2
4.2.2	Turning Radii – No Slip Angle: Model 767-300, -300ER, -300 Freighter	4-3
4.2.3	Turning Radii – No Slip Angle: Model 767-400ER	4-4
4.3	CLEARANCE RADII: MODEL 767-200, -200ER, -300, -300ER, -300 FREIGHTER -400ER.....	4-5
4.4	VISIBILITY FROM COCKPIT IN STATIC POSITION: MODEL 767- 200, -200ER, -300, -300ER, -300 FREIGHTER -400ER	4-6
4.5	RUNWAY AND TAXIWAY TURN PATHS	4-7
4.5.1	Runway and Taxiway Turnpaths - Runway-to-Taxiway, More Than 90 Degrees: Model 767-200, -200ER, -300, -300ER, -300 Freighter, -400ER.....	4-7
4.5.2	Runway and Taxiway Turnpaths - Runway-to-Taxiway, 90 Degrees: Model 767-200, -200ER, -300, -300ER, -300 Freighter, -400ER	4-8
4.5.3	Runway and Taxiway Turnpaths - Taxiway-to-Taxiway, 90 Degrees, Nose Gear Tracks Centerline: Model 767-200, -200ER, - 300, -300ER, -300 Freighter, -400ER.....	4-9
4.5.4	Runway and Taxiway Turnpaths - Taxiway-to-Taxiway, 90 Degrees, Cockpit Tracks Centerline: Model 767-200, -200ER, - 300, -300ER, -300 Freighter, -400ER.....	4-10
4.5.5	Runway and Taxiway Turnpaths - Taxiway-to-Taxiway, 90 Degrees, Judgmental Oversteer: Model 767-200, -200ER, -300, - 300ER, -300 Freighter, -400ER	4-11
4.6	RUNWAY HOLDING BAY: MODEL 767-200, -200ER, -300, -300ER, -300 FREIGHTER, -400ER.....	4-12
5.0	TERMINAL SERVICING	5-1
5.1	AIRPLANE SERVICING ARRANGEMENT - TYPICAL TURNAROUND	5-2
5.1.1	Airplane Servicing Arrangement - Typical Turnaround: Model 767-200, -200ER	5-2
5.1.2	Airplane Servicing Arrangement - Typical Turnaround: Model 767-300, -300ER	5-3
5.1.3	Airplane Servicing Arrangement - Typical Turnaround: Model 767-300, Freighter.....	5-4
5.1.4	Airplane Servicing Arrangement - Typical Turnaround: Model 767-400ER	5-5
5.2	TERMINAL OPERATIONS - TURNAROUND STATION	5-6
5.2.1	Terminal Operations - Turnaround Station - All Passenger: Model 767-200, -200ER – 2 Class	5-6
5.2.2	Terminal Operations - Turnaround Station - All Passenger: Model 767-200, -200ER – 3 Class	5-7

5.2.3	Terminal Operations - Turnaround Station - All Passenger: Model 767-300, -300ER – 2 Class	5-8
5.2.4	Terminal Operations - Turnaround Station - All Passenger: Model 767-300, -300ER – 3 Class	5-9
5.2.5	Terminal Operations - Turnaround Station - All Passenger: Model 767-300 Freighter	5-10
5.2.6	Terminal Operations - Turnaround Station - All Passenger: Model 767-400ER – 2 Class.....	5-11
5.2.7	Terminal Operations - Turnaround Station - All Passenger: Model 767-400ER – 3 Class.....	5-12
5.3	TERMINAL OPERATIONS - EN ROUTE STATION.....	5-13
5.3.1	Terminal Operations - En Route Station - All Passenger: Model 767-200, -200ER	5-13
5.3.2	Terminal Operations - En Route Station - All Passenger: Model 767-300, -300ER	5-14
5.3.3	Terminal Operations - En Route Station - All Passenger: Model 767-400ER	5-15
5.4	GROUND SERVICING CONNECTIONS.....	5-16
5.4.1	Ground Service Connections: Model 767-200, -200ER	5-16
5.4.2	Ground Service Connections: -300, -300ER.....	5-17
5.4.3	Ground Service Connections: Model 767-300 Freighter	5-18
5.4.4	Ground Service Connections: Model 767-400ER.....	5-19
5.4.5	Ground Service Connections and Capacities: Model 767-200, -200ER, -300, -300ER, -300 Freighter, -400ER	5-20
5.4.6	Ground Service Connections and Capacities: Model 767-200, -200ER, -300, -300ER, -300 Freighter, -400ER	5-21
5.4.7	Ground Service Connections and Capacities: Model 767-200, -200ER, -300, -300ER, -300 Freighter, -400ER	5-22
5.5	ENGINE STARTING PNEUMATIC REQUIREMENTS	5-23
5.5.1	Engine Start Pneumatic Requirements - Sea Level: Model 767-200, -200ER, -300, -300ER, -300 Freighter, -400ER (GE Engines).....	5-23
5.5.2	Engine Start Pneumatic Requirements - Sea Level: Model 767-200, -200ER, -300, -300ER, -300 Freighter, -400ER (P&W Engines).....	5-24
5.5.3	Engine Start Pneumatic Requirements - Sea Level: Model 767-200, -200ER, -300, -300ER, -300 Freighter, -400ER (GE Engines).....	5-25
5.5.4	Engine Start Pneumatic Requirements - Sea Level: Model 767-200, -200ER, -300, -300ER, -300 Freighter, -400ER (GE Engines).....	5-26
5.5.5	Engine Start Pneumatic Requirements - Sea Level: Model 767-200, -200ER, -300, -300ER, -300 Freighter (Rolls Royce Engines) ...	5-27

5.6	GROUND PNEUMATIC POWER REQUIREMENTS	5-28
5.6.1	Ground Pneumatic Power Requirements - Heating/Cooling: Model 767-200, -200ER.....	5-28
5.6.2	Ground Pneumatic Power Requirements - Heating/Cooling: Model 767-300, -300ER.....	5-29
5.6.3	Ground Pneumatic Power Requirements - Heating/Cooling: Model 767-400ER	5-30
5.7	CONDITIONED AIR REQUIREMENTS	5-31
5.7.1	Conditioned Air Flow Requirements – Steady State: Model 767- 200, -200ER	5-31
5.7.2	Conditioned Air Flow Requirements – Steady State: Model 767- 300, -300ER, -300 Freighter	5-32
5.7.3	Conditioned Air Flow Requirements – Steady State: Model 767-400ER	5-33
5.7.4	Conditioned Air Flow Pressure Requirements: Model 767-400ER.....	5-34
5.8	GROUND TOWING REQUIREMENTS	5-35
5.8.1	Ground Towing Requirements - English Units: Model 767- 200, -200ER, -300, -300ER, -300 Freighter, -400ER	5-35
5.8.2	Ground Towing Requirements - Metric Units: Model 767- 200, -200ER, -300, -300ER, -300 Freighter, -400ER	5-36
6.0	JET ENGINE WAKE AND NOISE DATA	6-1
6.1	JET ENGINE EXHAUST VELOCITIES AND TEMPERATURES	6-1
6.1.1	Jet Engine Exhaust Velocity Contours – Idle Thrust: Model 767- 200, -200ER, -300 (JT9D-7R4D, -7R4E Engines)	6-2
6.1.2	Jet Engine Exhaust Velocity Contours – Idle Thrust: Model 767- 200, -200ER, -300 (CF6-80A, -80A2 Engines)	6-3
6.1.3	Jet Engine Exhaust Velocity Contours – Idle Thrust: Model 767- 300, -300ER, -300 Freighter (PW4000, CF6-80C2 Series Engines).....	6-4
6.1.4	Jet Engine Exhaust Velocity Contours – Idle Thrust: Model 767- 300, -300ER, -300 Freighter (RB211-524 Engines)	6-5
6.1.5	Jet Engine Exhaust Velocity Contours – Idle Thrust: Model 767- 400ER (All Engines)	6-6
6.1.6	Jet Engine Exhaust Velocity Contours – Low Breakaway Thrust: Model 767-200, -200ER, -300 (JT9D-7R4D, -7R4E Engines).....	6-7
6.1.7	Jet Engine Exhaust Velocity Contours – Low Breakaway Thrust: Model 767-200, -200ER, -300 (CF6-80A, -80A2 Engines)	6-8
6.1.8	Jet Engine Exhaust Velocity Contours – Low Breakaway Thrust: Model 767-400ER (All Engines)	6-9
6.1.9	Jet Engine Exhaust Velocity Contours – High Breakaway Thrust: Model 767-200, -200ER, -300, -300ER, -300 Freighter (All Engines).....	6-10

6.1.10	Jet Engine Exhaust Velocity Contours – High Breakaway Thrust: Model 767-400ER (All Engines)	6-11
6.1.11	Jet Engine Exhaust Velocity Contours - Takeoff Thrust: Model 767-200, -200ER, -300 (JT9D-7R4D, -7R4E Engines).....	6-12
6.1.12	Jet Engine Exhaust Velocity Contours - Takeoff Thrust: Model 767-200, -200ER, -300 (CF6-80A, -80A2 Engines).....	6-13
6.1.13	Jet Engine Exhaust Velocity Contours - Takeoff Thrust: Model 767-300ER, -300 Freighter (PW4056, CF6-80C2 Engines).....	6-14
6.1.14	Jet Engine Exhaust Velocity Contours - Takeoff Thrust: Model 767-300, -300ER, -300 Freighter (RB211-524 Engines).....	6-15
6.1.15	Jet Engine Exhaust Velocity Contours - Takeoff Thrust: Model 767-400ER (All Engines).....	6-16
6.1.16	Jet Engine Exhaust Temperature Contours – Idle Thrust: Model 767-200, -200ER, -300, -300ER, -300 Freighter, -400ER (All Engines).....	6-17
6.1.17	Jet Engine Exhaust Temperature Contours - Breakaway Thrust: Model 767-200, -200ER, -300, -300ER, -300 Freighter, -400ER (All Engines)	6-18
6.1.18	Jet Engine Exhaust Temperature Contours - Takeoff Thrust: Model 767-200, -200ER, -300 (JT9D-7R4E, -7R4E Engines).....	6-19
6.1.19	Jet Engine Exhaust Temperature Contours - Takeoff Thrust: Model 767-200, -200ER, -300 (CF6-80A, -80A2 Engines)	6-20
6.1.20	Jet Engine Exhaust Temperature Contours - Takeoff Thrust: Model 767-300ER, -300 Freighter (PW4000, CF6-80C2 Engines)	6-21
6.1.21	Jet Engine Exhaust Temperature Contours - Takeoff Thrust: Model 767-300, -300ER, -300 Freighter (RB211-524 Engines)	6-22
6.1.22	Jet Engine Exhaust Temperature Contours - Takeoff Thrust: Model 767-400ER (All Engines)	6-23
6.2	AIRPORT AND COMMUNITY NOISE.....	6-24
7.0	PAVEMENT DATA	7-1
7.1	GENERAL INFORMATION.....	7-1
7.2	LANDING GEAR FOOTPRINT	7-3
7.2.1	Landing Gear Footprint: Model 767-200, -200ER	7-3
7.2.2	Landing Gear Footprint: Model 767-300, -300ER, -300 Freighter	7-4
7.2.3	Landing Gear Footprint: Model 767-400ER.....	7-5
7.3	MAXIMUM PAVEMENT LOADS.....	7-6
7.3.1	Maximum Pavement Loads: Model 767-200, -200ER,-300,-300ER.....	7-6
7.3.2	Maximum Pavement Loads: Model 767-400ER, -300 Freighter.....	7-7
7.4	LANDING GEAR LOADING ON PAVEMENT	7-8
7.4.1	Landing Gear Loading on Pavement: Model 767-200.....	7-8
7.4.2	Landing Gear Loading On Pavement: Model 767-200ER.....	7-9

7.4.3	Landing Gear Loading On Pavement: Model 767-300.....	7-10
7.4.4	Landing Gear Loading On Pavement: Model 767-300ER.....	7-11
7.4.5	Landing Gear Loading On Pavement: Model 767-300F.....	7-12
7.4.6	Landing Gear Loading On Pavement: Model 767-400ER.....	7-13
7.5	FLEXIBLE PAVEMENT REQUIREMENTS - U.S. ARMY CORPS OF ENGINEERS METHOD S-77-1	7-14
7.5.1	Flexible Pavement Requirements - U.S. Army Corps of Engineers Design Method (S-77-1): Model 767-200, -200ER, -300, -300ER, -300 Freighter.....	7-15
7.5.2	Flexible Pavement Requirements - U.S. Army Corps of Engineers Design Method (S-77-1): Model 767-400ER	7-16
7.6	FLEXIBLE PAVEMENT REQUIREMENTS - LCN CONVERSION.....	7-17
7.7	RIGID PAVEMENT REQUIREMENTS - PORTLAND CEMENT ASSOCIATION DESIGN METHOD.....	7-18
7.7.1	Rigid Pavement Requirements - Portland Cement Association Design Method: Model 767-200, -200ER, -300, -300ER, -300 Freighter	7-19
7.7.2	Rigid Pavement Requirements - Portland Cement Association Design Method: Model 767-400ER.....	7-20
7.8	RIGID PAVEMENT REQUIREMENTS - LCN CONVERSION	7-21
7.9	RIGID PAVEMENT REQUIREMENTS - FAA DESIGN METHOD	7-22
7.10	ACN/PCN REPORTING SYSTEM - FLEXIBLE AND RIGID PAVEMENTS	7-23
7.10.1	Aircraft Classification Number - Flexible Pavement: Model 767-200.....	7-24
7.10.2	Aircraft Classification Number - Flexible Pavement: Model 767-200ER	7-25
7.10.3	Aircraft Classification Number - Flexible Pavement: Model 767-300.....	7-26
7.10.4	Aircraft Classification Number - Flexible Pavement: Model 767-300ER, -300 Freighter	7-27
7.10.5	Aircraft Classification Number - Flexible Pavement: Model 767-400ER	7-28
7.10.6	Aircraft Classification Number - Rigid Pavement: Model 767-200	7-29
7.10.7	Aircraft Classification Number - Rigid Pavement: Model 767-200ER.....	7-30
7.10.8	Aircraft Classification Number - Rigid Pavement: Model 767-300	7-31
7.10.9	Aircraft Classification Number - Rigid Pavement: Model 767-300ER, -300 Freighter.....	7-32
7.10.10	Aircraft Classification Number - Rigid Pavement: Model 767-400ER	7-33
8.0	FUTURE 767 DERIVATIVE AIRPLANES.....	8-1

9.0	SCALED 767 DRAWINGS	9-1
9.1	MODEL 767-200, -200ER	9-2
9.1.1	Scaled Drawings – 1 IN. = 32 FT: Model 767-200, -200ER	9-2
9.1.2	Scaled Drawings – 1 IN. = 32 FT: Model 767-200, -200ER	9-3
9.1.3	Scaled Drawings – 1 IN. = 50 FT: Model 767-200, -200ER	9-4
9.1.4	Scaled Drawings – 1 IN. = 50 FT: Model 767-200, -200ER	9-5
9.1.5	Scaled Drawings – 1 IN. = 100 FT: Model 767-200, -200ER	9-6
9.1.6	Scaled Drawings – 1 IN. = 100 FT: Model 767-200, -200ER	9-7
9.1.7	Scaled Drawings – 1:500: Model 767-200, -200ER	9-8
9.1.8	Scaled Drawings – 1:500: Model 767-200, -200ER	9-9
9.1.9	Scaled Drawings – 1:1000: Model 767-200, -200ER	9-10
9.1.10	Scaled Drawings – 1:1000: Model 767-200, -200ER	9-11
9.2	MODEL 767-300, -300ER	9-12
9.2.1	Scaled Drawings – 1 IN. = 32 FT: Model 767-300, -300ER	9-12
9.2.2	Scaled Drawings – 1 IN. = 32 FT: Model 767-300, -300ER	9-13
9.2.3	Scaled Drawings – 1 IN. = 50 FT: Model 767-300, -300ER	9-14
9.2.4	Scaled Drawings – 1 IN. = 50 FT: Model 767-300, -300ER	9-15
9.2.5	Scaled Drawings – 1 IN. = 100 FT: Model 767-300, -300ER	9-16
9.2.6	Scaled Drawings – 1 IN. = 100 FT: Model 767-300, -300ER	9-17
9.2.7	Scaled Drawings – 1:500: Model 767-300, -300ER	9-18
9.2.8	Scaled Drawings – 1:500: Model 767-300, -300ER	9-19
9.2.9	Scaled Drawings – 1:1000: Model 767-300, -300ER	9-20
9.2.10	Scaled Drawings – 1:1000: Model 767-300, -300ER	9-21
9.3	MODEL 767-300 FREIGHTER.....	9-22
9.3.1	Scaled Drawings – 1 IN. = 32 FT: Model 767-300 Freighter	9-22
9.3.2	Scaled Drawings – 1 IN. = 32 FT: Model 767-300 Freighter	9-23
9.3.3	Scaled Drawings – 1 IN. = 50 FT: Model 767-300 Freighter	9-24
9.3.4	Scaled Drawings – 1 IN. = 50 FT: Model 767-300 Freighter	9-25
9.3.5	Scaled Drawings – 1 IN. = 100 FT: Model 767-300 Freighter	9-26
9.3.6	Scaled Drawings – 1 IN. = 100 FT: Model 767-300 Freighter	9-27
9.3.7	Scaled Drawings – 1:500: Model 767-300 Freighter	9-28
9.3.8	Scaled Drawings – 1:500: Model 767-300 Freighter	9-29
9.3.9	Scaled Drawings – 1:1000: Model 767-300 Freighter	9-30
9.3.10	Scaled Drawings – 1:1000: Model 767-300 Freighter	9-31
9.4	MODEL 767-400ER.....	9-32
9.4.1	Scaled Drawings – 1 IN. = 32 FT: Model 767-400ER	9-32
9.4.2	Scaled Drawings – 1 IN. = 32 FT: Model 767-400ER	9-33
9.4.3	Scaled Drawings – 1 IN. = 50 FT: Model 767-400ER	9-34
9.4.4	Scaled Drawings – 1 IN. = 50 FT: Model 767-400ER	9-35
9.4.5	Scaled Drawings – 1 IN. = 100 FT: Model 767-400ER	9-36
9.4.6	Scaled Drawings – 1 IN. = 100 FT: Model 767-400ER	9-37

9.4.7	Scaled Drawings – 1:500: Model 767-400ER	9-38
9.4.8	Scaled Drawings – 1:500: Model 767-400ER	9-39
9.4.9	Scaled Drawings – 1:1000: Model 767-400ER	9-40
9.4.10	Scaled Drawings – 1:1000: Model 767-400ER	9-41

1.0 SCOPE AND INTRODUCTION

1.1 SCOPE

This document provides, in a standardized format, airplane characteristics data for general airport planning. Since operational practices vary among airlines, specific data should be coordinated with the using airlines prior to facility design. Boeing Commercial Airplanes should be contacted for any additional information required.

Content of the document reflects the results of a coordinated effort by representatives from the following organizations:

- Aerospace Industries Association
- Airports Council International - North America
- Air Transport Association of America
- International Air Transport Association

The airport planner may also want to consider the information presented in the "Commercial Aircraft Design Characteristics – Trends and Growth Projections," available from the US AIA, 1250 Eye St., Washington DC 20005, for long-range planning needs. This document is updated periodically and represents the coordinated efforts of the following organizations regarding future aircraft growth trends:

- International Coordinating Council of Aerospace Industries Associations
- Airports Council International - North American and World Organizations
- Air Transport Association of America
- International Air Transport Association

1.2 INTRODUCTION

This document conforms to NAS 3601. It provides characteristics of the Boeing Model 767 airplane for airport planners and operators, airlines, architectural and engineering consultant organizations, and other interested industry agencies. Airplane changes and available options may alter model characteristics; the data presented herein reflect typical airplanes in each model category.

For additional information contact:

Boeing Commercial Airplanes
2201 Seal Beach Blvd. M/C: 110-SB02
Seal Beach, CA 90740-1515
U.S.A.

Attention: Manager, Airport Compatibility Engineering

Phone: 562-797-1172

Email: AirportCompatibility@boeing.com

1.3 A BRIEF DESCRIPTION OF THE 767

The 767 is a twin-engine family of airplanes designed for medium to long range flights. It is powered by advanced high bypass ratio engines. Characteristics unique to the 767 include:

- Advanced aerodynamics
- Stronger and lighter materials
- Two-crew cockpit with digital flight deck systems
- High bypass ratio engines
- Twin-aisle seating
- Extended range operations

767-200, -200ER

The 767-200 can carry up to 216 passengers and baggage over 3,900 nautical miles. The 767-200ER, with the center fuel tanks can also carry 216 passengers and baggage on routes over 5,200 nautical miles. Seating arrangement varies with airline option. Both airplane models have identical outside dimensions.

767-300, -300ER

The 767-300 and -300ER are 21 feet 1 inch longer than the 767-200. The additional length enables the airplane to carry more passengers. The -300ER is also fitted with center fuel tanks for additional range. Except for the longer fuselage, the -300 and the -300ER have dimensions identical to the

-200 and -200ER

The -300 and -300ER can be fitted with an optional mid-cabin door to facilitate loading and unloading of passengers. This arrangement also allows alternate passenger accommodations, up to and including maximum passenger capacity (exit limit).

767-300 Freighter

The 767-300 Freighter is equipped with a main deck cargo door that enables it to load cargo containers and/or pallets on the main deck. The main deck can accommodate either a manual cargo handling system or a powered transfer system (General Market Freighter). The 767-300 Freighter does not have windows and doors, except for the left entry door for crew access.

767-400ER

The 767-400ER is 21 feet longer than the 767-300. The -400ER is equipped with a new-generation wing design and new engines to enable it to achieve long range operations along with the additional payload.

Military Derivatives

The 767-200 airplane is also delivered for military uses. These derivatives are not mentioned in this document because they are equipped with special equipment used for special missions. Some of the external dimensions may be similar to the standard 767-200 airplane such that some of the data in this document can be used.

Extended Range Operations (ETOPS)

The 767 can be equipped with special features to enable it to fly extended range operations in remote areas. This feature is standard on the 767-400ER.

767 Engines

The 767 is offered with a variety of engines. These engines are high bypass ratio engines which are more economical to maintain and are more efficient. See Table 1.3.1 for engine applicability.

Cargo Handling

The lower lobe cargo compartments can accommodate a variety of containers and pallets now used in narrow-body and wide-body airplanes. The optional large forward cargo door (standard on the 767-200ER, 767-300ER, 767-300 Freighter, and 767-400ER) allow loading of 96- by 125-in (2.44 by 3.18 m) pallets and also split-engine carriage kits. In addition, bulk cargo is loaded in the aft cargo compartment and the forward cargo compartment where space permits.

Ground Servicing

The 767 has ground service connections compatible with existing ground service equipment, and no special equipment is necessary.

Document Applicability

This document contains data pertinent to all 767 airplane models (767-200/200ER/300/300ER/300 Freighter/400ER).

1.3.1 Brief Description – Engine/Weight Combinations: 767

ENGINE MODEL (2 EACH)	RATED SLST THRUST PER ENGINE	MAXIMUM DESIGN TAXI WEIGHT – 1,000 LB (1,000 KG)					
		767-200	767-200ER	767-300	767-300ER	767-300 FREIGHTER	767-400ER
JT9D-7R4D	48,000 LB (21,772 KG)	284.0 (128.8) 302.0 (137.0) 312.0 (141.5) 317.0 (143.8)	337.0 (152.9) 347.0 (157.4) 352.2 (159.8)	347.0 (157.4) 352.0 (159.7)	NOT AVAILABLE	NOT AVAILABLE	NOT AVAILABLE
CF6-80A	48,000 LB (21,772 KG)						
JT9D-7R4E	50,000 LB (22,680 KG)						
CF6-80A2	50,000 LB (22,680 KG)						
PW4052	50,200 LB (22,770 KG)	302.0 (137.0)	337.0 (152.9) 347.0 (157.4) 352.2 (159.8)	NOT AVAILABLE	NOT AVAILABLE		
CF6-80C2-B2	52,500 LB (23,814 KG)	312.0 (141.5) 317.0 (143.8)					
CF6-80C2-B4	57,900 LB (26,263 KG)	NOT AVAILABLE				NOT AVAILABLE	
PW4056	56,750 LB (25,741 KG)						
PW4060	60,000 LB (27,216 KG)						
CF6-80C2-B6	61,500 LB (27,896 KG)						
RB211-524G	58,000 LB (26,308 KG)		337.0 (152.9) 347.0 (157.4) 352.2 (159.8)	347.0 (157.4) 352.0 (159.7)			
RB211-524H	60,600 LB (27,488 KG)		381.0 (172.8) 388.0 (176.0) 396.0 (179.6)				
CF6-80C2-B8F	60,600 LB (27,488 KG)		NOT AVAILABLE	NOT AVAILABLE	381.0 (172.8) 388.0 (176.0) 401.0 (181.9) 409.0 (185.5) 413.0 (187.3)		381.0 (172.8) 388.0 (176.0) 401.0 (181.9) 409.0 (185.5) 413.0 (187.3)
CF6-80C2-B7F1	60,600 LB (27,488 KG)						
PW4062	60,600 LB (27,488 KG)	451.0 (204.6)					

NOTES:

- ENGINE/TAXI WEIGHT COMBINATIONS SHOWN ARE AS DELIVERED OR AS OFFERED BY BOEING COMMERCIAL AIRPLANES. CERTAIN ENGINES MAY NOT YET BE CERTIFICATED.
- CONSULT WITH USING AIRLINE FOR ACTUAL OR PLANNED ENGINE/WEIGHT COMBINATION.
- SEE SECTION 2.1 GENERAL CHARACTERISTICS FOR DETAILS ON SELECTED AIRPLANES.

2.0 AIRPLANE DESCRIPTION

2.1 GENERAL CHARACTERISTICS

Maximum Design Taxi Weight (MTW). Maximum weight for ground maneuver as limited by aircraft strength and airworthiness requirements. (It includes weight of taxi and run-up fuel.)

Maximum Design Takeoff Weight (MTOW). Maximum weight for takeoff as limited by aircraft strength and airworthiness requirements. (This is the maximum weight at start of the takeoff run.)

Maximum Design Landing Weight (MLW). Maximum weight for landing as limited by aircraft strength and airworthiness requirements.

Maximum Design Zero Fuel Weight (MZFW). Maximum weight allowed before usable fuel and other specified usable agents must be loaded in defined sections of the aircraft as limited by strength and airworthiness requirements.

Spec Operating Empty Weight (OEW). Weight of structure, powerplant, furnishing systems, unusable fuel and other unusable propulsion agents, and other items of equipment that are considered an integral part of a particular airplane configuration. Also included are certain standard items, personnel, equipment, and supplies necessary for full operations, excluding usable fuel and payload.

Maximum Structural Payload. Maximum design zero fuel weight minus operational empty weight.

Maximum Seating Capacity. The maximum number of passengers specifically certificated or anticipated for certification.

Maximum Cargo Volume. The maximum space available for cargo.

Usable Fuel. Fuel available for aircraft propulsion.

2.1.1 General Characteristics: Model 767-200

CHARACTERISTICS	UNITS	767-200 (1)			
MAX DESIGN TAXI WEIGHT	POUNDS	284,000	302,000	312,000	317,000
	KILOGRAMS	128,820	136,985	141,521	143,789
MAX DESIGN TAKEOFF WEIGHT	POUNDS	282,000	300,000	310,000	315,000
	KILOGRAMS	127,913	136,078	140,614	142,882
MAX DESIGN LANDING WEIGHT	POUNDS	257,000	270,000	270,000	272,000
	KILOGRAMS	116,573	122,470	122,470	123,377
MAX DESIGN ZERO FUEL WEIGHT	POUNDS	242,000	248,000	248,000	250,000
	KILOGRAMS	109,769	112,491	112,491	113,398
SPEC OPERATING EMPTY WEIGHT (2)	POUNDS	174,110	177,000	176,550	176,650
	KILOGRAMS	78,975	80,286	80,082	80,127
MAX STRUCTURAL PAYLOAD	POUNDS	67,890	71,000	71,450	73,350
	KILOGRAMS	30,794	32,205	32,409	33,271
SEATING CAPACITY	ONE-CLASS	FAA EXIT LIMIT = 255 (3)			
	MIXED CLASS	216 - 18 FIRST + 198 ECONOMY			
MAX CARGO LOWER DECK	CUBIC FEET	3,070	3,070	3,070	3,070
	CUBIC METERS	86.9	86.9	86.9	86.9
USABLE FUEL	U.S. GALLONS	12,140	16,700	16,700	16,700
	LITERS	45,955	63,217	63,217	63,217
	POUNDS	81,338	111,890	111,890	111,890
	KILOGRAMS	36,894	50,753	50,753	50,753

NOTES:

1. SPEC WEIGHT FOR TYPICAL ENGINE/WEIGHT CONFIGURATION SHOWN SEE TABLE 1.3.1 FOR COMBINATIONS AVAILABLE. CONSULT WITH AIRLINE FOR SPECIFIC WEIGHTS AND CONFIGURATIONS.
2. TYPICAL OPERATING EMPTY WEIGHT SHOWN. ACTUAL WEIGHT WILL DEPEND ON SPECIFIC AIRLINE CONFIGURATION.
3. 290 WITH SECOND OVERWING EXIT DOOR.

2.1.2 General Characteristics: Model 767-200ER

CHARACTERISTICS	UNITS	767-200ER (1)					
MAX DESIGN TAXI WEIGHT	POUNDS	337,000	347,000	352,200	381,000	388,000	396000
	KILOGRAMS	152,861	157,397	159,755	172,819	175,994	179,623
MAX DESIGN TAKEOFF WEIGHT	POUNDS	335,000	345,000	351,000	380,000	387,000	395000
	KILOGRAMS	151,954	156,490	159,211	172,365	175,540	179,169
MAX DESIGN LANDING WEIGHT	POUNDS	278,000	278,000	278,000	285,000	285,000	300000
	KILOGRAMS	126,099	126,099	126,099	129,274	129,274	136,078
MAX DESIGN ZERO FUEL WEIGHT	POUNDS	253,000	253,000	253,000	260,000	260,000	260000
	KILOGRAMS	114,759	114,759	114,759	117,934	117,934	117,934
SPEC OPERATING EMPTY WEIGHT (2)	POUNDS	181,130	181,250	181,350	181,500	181,610	181610
	KILOGRAMS	82,159	82,214	82,259	82,327	82,377	82,377
MAX STRUCTURAL PAYLOAD	POUNDS	71,870	71,750	71,650	78,500	78,390	78,390
	KILOGRAMS	32,600	32,545	32,500	35,607	35,557	35,557
SEATING CAPACITY	ONE-CLASS	FAA EXIT LIMIT = 255 (3)					
	MIXED CLASS	216 - 18 FIRST + 198 ECONOMY					
MAX CARGO LOWER DECK	CUBIC FEET	3,070	3,070	3,070	3,070	3,070	3,070
	CUBIC METERS	86.9	86.9	86.9	86.9	86.9	86.9
USABLE FUEL	U.S. GALLONS	16,700	20,540	20,540	24,140	24,140	24140
	LITERS	63,216	77,752	77,752	91,380	91,380	91,380
	POUNDS	111,890	137,618	137,618	161,738	161,738	161,738
	KILOGRAMS	50,752	62,422	62,422	73,363	73,363	73,363

NOTES:

1. SPEC WEIGHT FOR TYPICAL ENGINE/WEIGHT CONFIGURATION SHOWN SEE TABLE 1.3.1 FOR COMBINATIONS AVAILABLE. CONSULT WITH AIRLINE FOR SPECIFIC WEIGHTS AND CONFIGURATIONS.
2. TYPICAL OPERATING EMPTY WEIGHT SHOWN. ACTUAL WEIGHT WILL DEPEND ON SPECIFIC AIRLINE CONFIGURATION.
3. 290 WITH SECOND OVERWING EXIT DOOR.

2.1.3 General Characteristics: Model 767-300

CHARACTERISTICS	UNITS	767-300 (1)	
MAX DESIGN TAXI WEIGHT	POUNDS	347,000	352,000
	KILOGRAMS	157,397	159,665
MAX DESIGN TAKEOFF WEIGHT	POUNDS	345,000	350,000
	KILOGRAMS	156,490	158,758
MAX DESIGN LANDING WEIGHT	POUNDS	300,000	300,000
	KILOGRAMS	136,078	136,078
MAX DESIGN ZERO FUEL WEIGHT	POUNDS	278,000	278,000
	KILOGRAMS	126,099	126,099
SPEC OPERATING EMPTY WEIGHT (2)	POUNDS	186,380	189,750
	KILOGRAMS	84,541	86,069
MAX STRUCTURAL PAYLOAD	POUNDS	91,620	88,250
	KILOGRAMS	41,558	40,230
SEATING CAPACITY	ONE-CLASS	FAA EXIT LIMIT 290 (3)	
	MIXED CLASS	261 - 24 FIRST + 237 ECONOMY	
MAX CARGO LOWER DECK	CUBIC FEET	4,030	4,030
	CUBIC METERS	114.1	114.1
USABLE FUEL	U.S. GALLONS	16,700	16,700
	LITERS	63,216	63,216
	POUNDS	111,890	111,890
	KILOGRAMS	50,753	50,753

NOTES:

1. SPEC WEIGHT FOR TYPICAL ENGINE/WEIGHT CONFIGURATION SHOWN SEE TABLE 1.3.1 FOR COMBINATIONS AVAILABLE. CONSULT WITH AIRLINE FOR SPECIFIC WEIGHTS AND CONFIGURATIONS.
2. TYPICAL OPERATING EMPTY WEIGHT SHOWN. ACTUAL WEIGHT WILL DEPEND ON SPECIFIC AIRLINE CONFIGURATION.
3. 299 WITH MID-CABIN TYPE A DOOR.

2.1.4 General Characteristics: Model 767-300ER

CHARACTERISTICS	UNITS	767-300ER (1)				
MAX DESIGN TAXI WEIGHT	POUNDS	381,000	388,000	401,000	409,000	413,000
	KILOGRAMS	172,819	175,994	181,891	185,519	187,334
MAX DESIGN TAKEOFF WEIGHT	POUNDS	380,000	387,000	400,000	407,000	412,000
	KILOGRAMS	172,365	175,540	181,437	184,612	186,880
MAX DESIGN LANDING WEIGHT	POUNDS	300,000	300,000	320,000	320,000	320,000
	KILOGRAMS	136,078	136,078	145,150	145,150	145,150
MAX DESIGN ZERO FUEL WEIGHT	POUNDS	278,000	278,000	288,000	295,000	295,000
	KILOGRAMS	126,099	126,099	130,635	133,810	133,810
SPEC OPERATING EMPTY WEIGHT (2)	POUNDS	193,840	193,940	195,040	198,440	198,440
	KILOGRAMS	87,924	87,970	88,469	90,011	90,011
MAX STRUCTURAL PAYLOAD	POUNDS	84,160	84,060	92,960	96,560	96,560
	KILOGRAMS	38,174	38,129	42,166	43,799	43,799
SEATING CAPACITY	ONE-CLASS	FAA EXIT LIMIT = 290 (3)				
	MIXED CLASS	261 - 24 FIRST + 237 ECONOMY				
MAX CARGO LOWER DECK	CUBIC FEET	4,030	4,030	4,030	4,030	4,030
	CUBIC METERS	114.1	114.1	114.1	114.1	114.1
USABLE FUEL	U.S. GALLONS	24,140	24,140	24,140	24,140	24,140
	LITERS	91,380	91,380	91,380	91,380	91,380
	POUNDS	161,740	161,740	161,740	161,740	161,740
	KILOGRAMS	73,364	73,364	73,364	73,364	73,364

NOTES:

1. SPEC WEIGHT FOR TYPICAL ENGINE/WEIGHT CONFIGURATION SHOWN SEE TABLE 1.3.1 FOR COMBINATIONS AVAILABLE. CONSULT WITH AIRLINE FOR SPECIFIC WEIGHTS AND CONFIGURATIONS.
2. TYPICAL OPERATING EMPTY WEIGHT SHOWN. ACTUAL WEIGHT WILL DEPEND ON SPECIFIC AIRLINE CONFIGURATION.
3. 299 WITH SECOND OVERWING EXIT DOOR

2.1.5 General Characteristics: Model 767-300 Freighter

CHARACTERISTICS	UNITS	767-300 FREIGHTER (1)					
		CF6-80C2F		PW 4000		RB211-524	
MAX DESIGN TAXI WEIGHT	POUNDS	409,000	413,000	409,000	413,000	409,000	413,000
	KILOGRAMS	185,519	187,334	185,519	187,334	185,519	187,334
MAX DESIGN TAKEOFF WEIGHT	POUNDS	408,000	412,000	408,000	412,000	408,000	412,000
	KILOGRAMS	185,066	186,880	185,066	186,880	185,066	186,880
MAX DESIGN LANDING WEIGHT	POUNDS	326,000	326,000	326,000	326,000	326,000	326,000
	KILOGRAMS	147,871	147,871	147,871	147,871	147,871	147,871
MAX DESIGN ZERO FUEL WEIGHT	POUNDS	309,000	309,000	309,000	309,000	309,000	309,000
	KILOGRAMS	140,160	140,160	140,160	140,160	140,160	140,160
SPEC OPERATING EMPTY WEIGHT (2)	POUNDS	188,000	188,000	188,100	188,100	190,000	190,000
	KILOGRAMS	85,275	85,275	85,321	85,321	86,183	86,183
MAX STRUCTURAL PAYLOAD	POUNDS	121,000	121,000	120,900	120,900	119,000	119,000
	KILOGRAMS	54,885	54,885	54,839	54,839	53,978	53,978
MAX CARGO MAIN DECK	(3) UP TO 24 TYPE A PALLETS AND 2 SPECIAL CONTOURED PALLETS						
	(4) UP TO 14 M-1 PALLETS AND 2 SPECIAL CONTOURED PALLETS						
MAX CARGO LOWER DECK	CUBIC FEET	4,030	4,030	4,030	4,030	4,030	4,030
	CUBIC METERS	114.1	114.1	114.1	114.1	114.1	114.1
USABLE FUEL	U.S. GALLONS	24,140	24,140	24,140	24,140	24,140	24,140
	LITERS	91,380	91,380	91,380	91,380	91,380	91,380
	POUNDS	161,740	161,740	161,740	161,740	161,740	161,740
	KILOGRAMS	73,364	73,364	73,364	73,364	73,364	73,364

NOTES:

1. SPEC WEIGHT FOR TYPICAL ENGINE/WEIGHT CONFIGURATION SHOWN WEIGHTS AND CONFIGURATIONS.
2. TYPICAL OPERATING EMPTY WEIGHT SHOWN. ACTUAL WEIGHT WILL DEPEND ON SPECIFIC AIRLINE CONFIGURATION.
3. 767-300 FREIGHTER - SEE SEC 2.4.6 FOR PALLET DETAILS.
4. 767-300 GENERAL MARKET FREIGHTER - SEE SEC 2.4.6 FOR PALLET DETAILS.

2.1.6 General Characteristics: Model 767-400ER

CHARACTERISTICS	UNITS	767-400ER (1)	
		GE ENGINES	PW ENGINES
MAX DESIGN TAXI WEIGHT	POUNDS	451,000	451,000
	KILOGRAMS	204,570	204,570
MAX DESIGN TAKEOFF WEIGHT	POUNDS	450,000	450,000
	KILOGRAMS	204,116	204,116
MAX DESIGN LANDING WEIGHT	POUNDS	350,000	350,000
	KILOGRAMS	158,757	158,757
MAX DESIGN ZERO FUEL WEIGHT	POUNDS	330,000	330,000
	KILOGRAMS	149,685	149,685
SPEC OPERATING EMPTY WEIGHT (2)	POUNDS	227,400	229,000
	KILOGRAMS	103,147	103,872
MAX STRUCTURAL PAYLOAD	POUNDS	102,600	101,000
	KILOGRAMS	46,538	45,813
SEATING CAPACITY	ONE-CLASS	409 ALL ECONOMY	
	TWO-CLASS	296 - 24 FIRST + 272 ECONOMY	
	THREE-CLASS	243 - 16 FIRST + 36 BUSINESS + 189 ECONOMY	
MAX CARGO LOWER DECK	CUBIC FEET	4,905	4,905
	CUBIC METERS	138.9	138.9
USABLE FUEL	U.S. GALLONS	24,140	24,140
	LITERS	91,370	91,370
	POUNDS	161,738	161,738
	KILOGRAMS	73,363	73,363

NOTES:

- SPEC WEIGHT FOR BASELINE CONFIGURATION OF 296 PASSENGERS. CONSULT WITH AIRLINE FOR SPECIFIC WEIGHTS AND CONFIGURATIONS..
- FWD CARGO = 20 LD-2 CONTAINERS AT 120 CU FT EACH
AFT CARGO = 18 LD-2 CONTAINERS AT 120 CU FT EACH
BULK CARGO = 345 CU F

2.2 GENERAL DIMENSIONS

2.2.1 General Dimensions: Model 767-200, -200ER

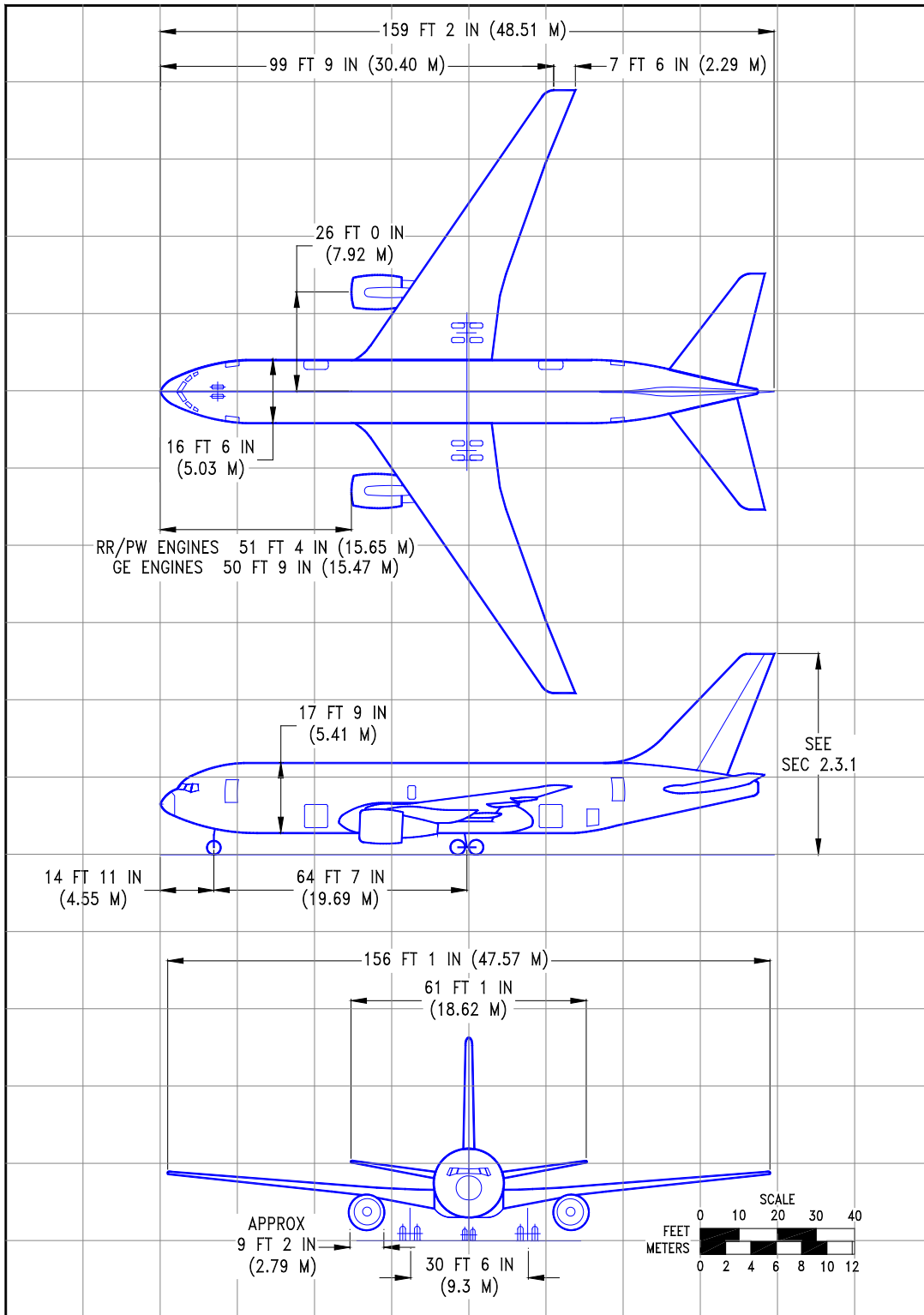

D6-58328

REV I

July 2021

2-8

2.2.2 General Dimensions: Model 767-300, -300ER

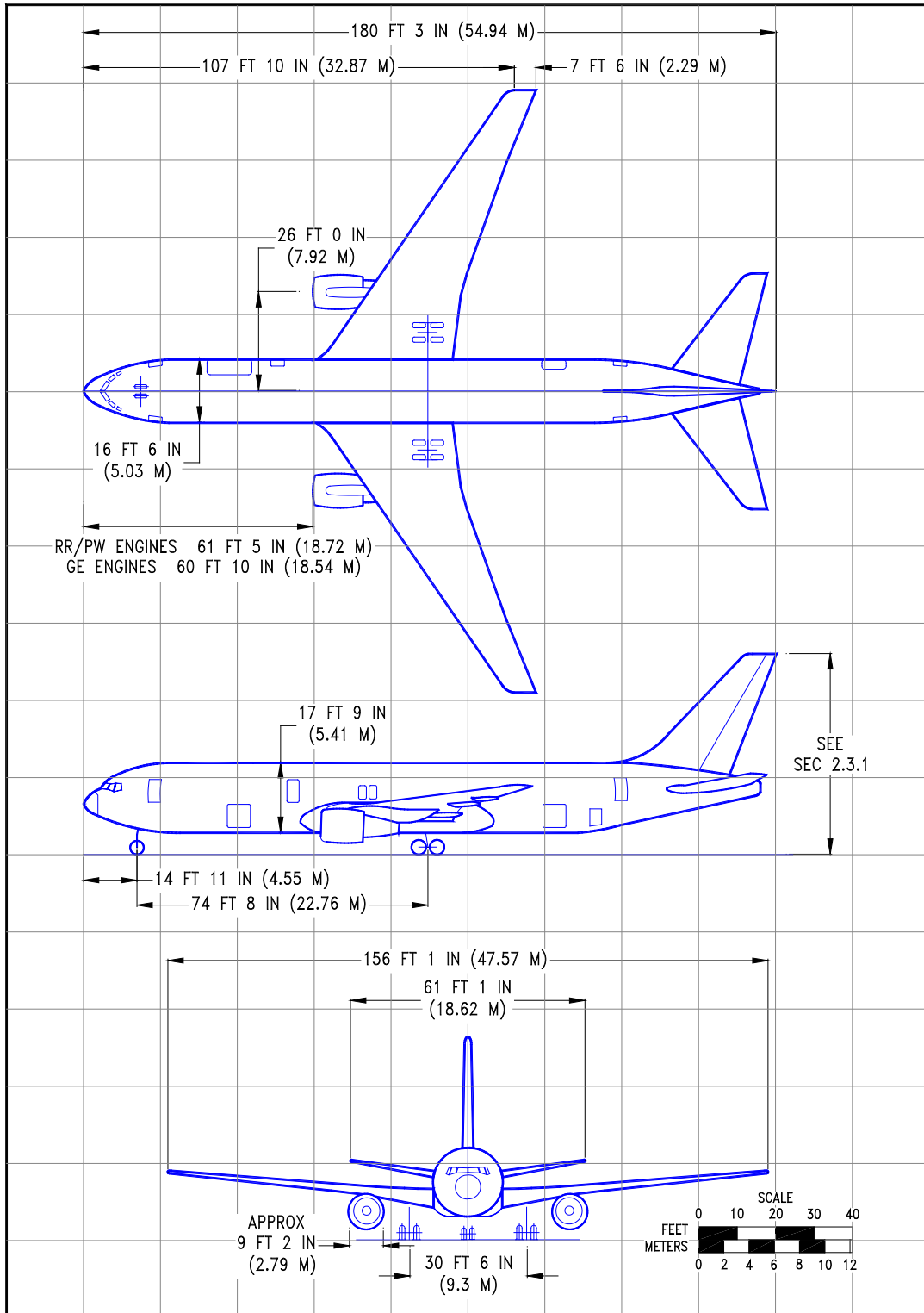

D6-58328

REV I

July 2021

2-9

2.2.3 General Dimensions: Model 767-300 Freighter

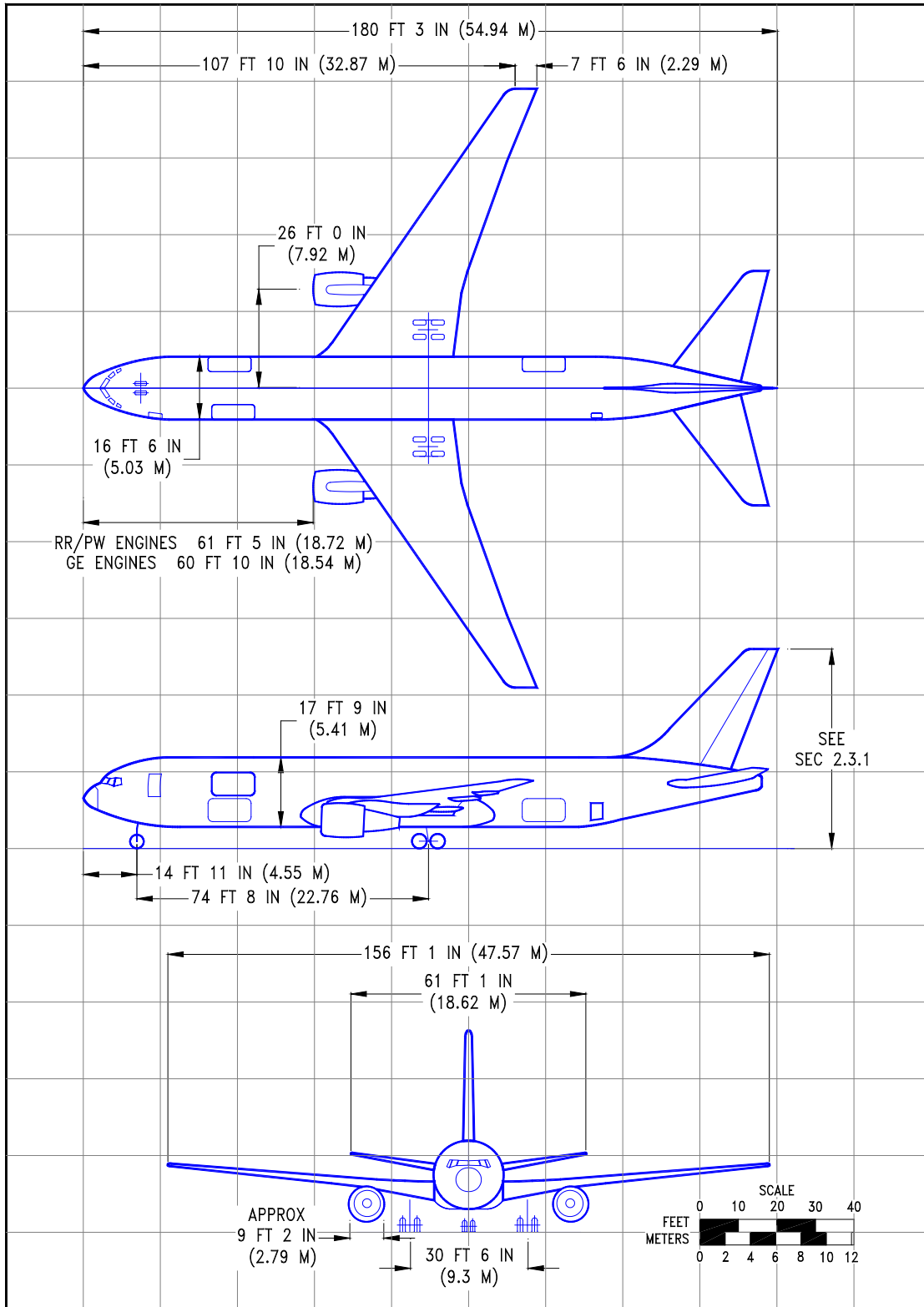

D6-58328

REV I

July 2021

2-10

2.2.4 General Dimensions: Model 767-400ER

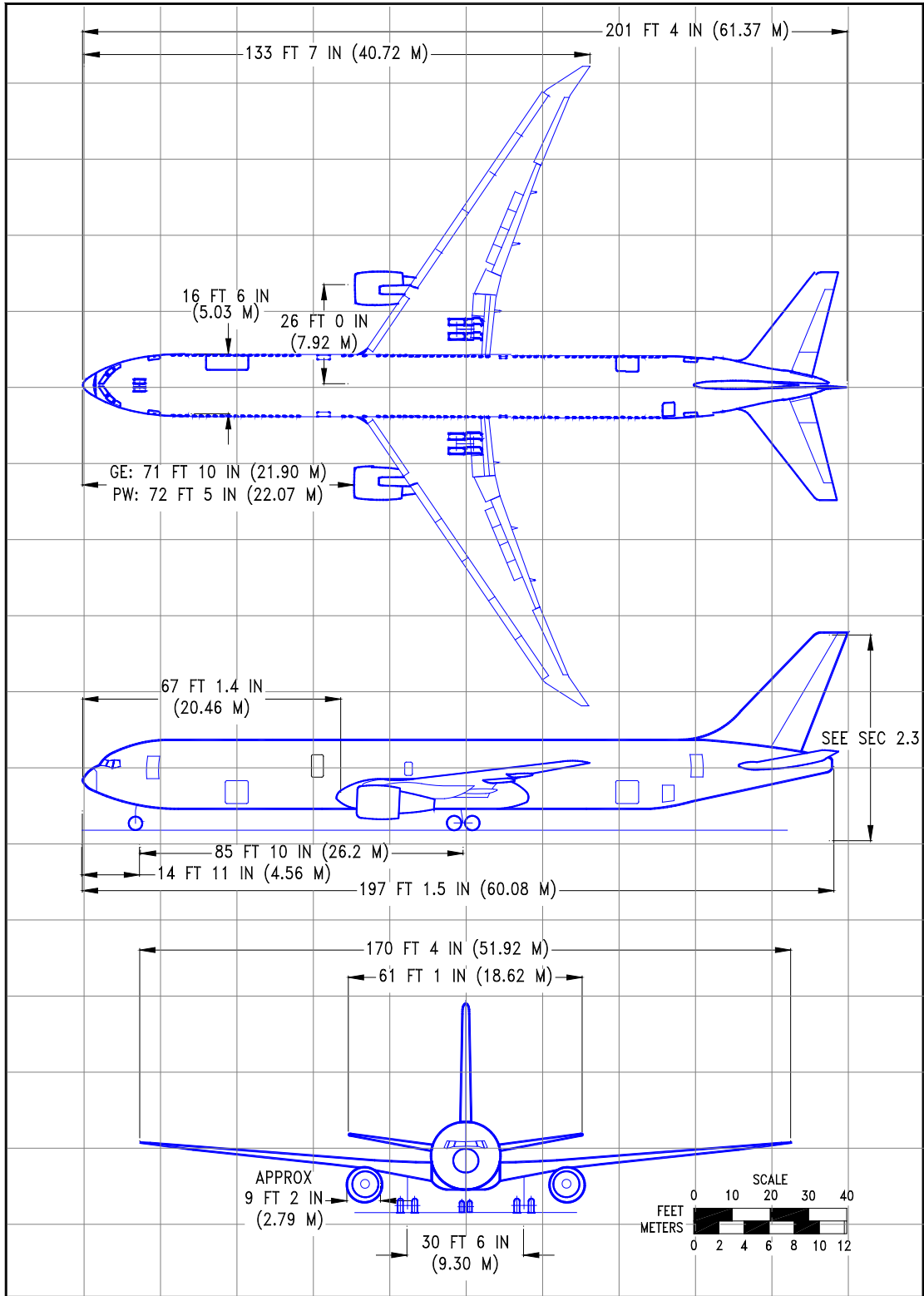

D6-58328

REV I

July 2021

2-11

2.3 GROUND CLEARANCES

2.3.1 Ground Clearances: Model 767-200, -200ER

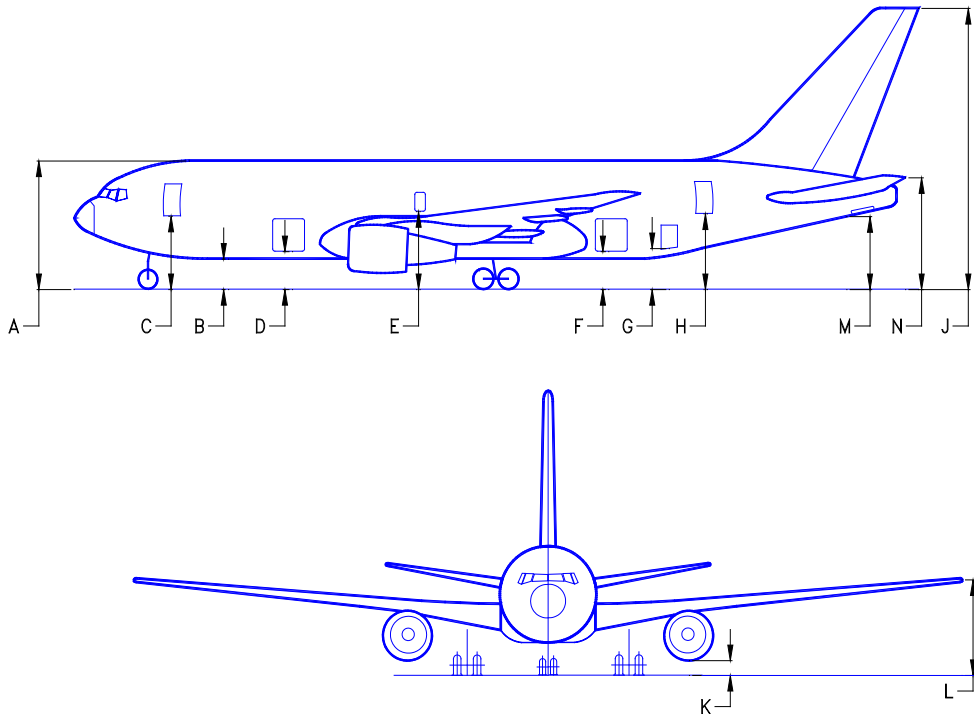

Dimension	MINIMUM		MAXIMUM	
	FEET - INCHES	METERS	FEET - INCHES	METERS
A	23 - 6	7.16	24 - 6	7.47
B	5 - 8	1.73	6 - 9	2.06
C	13 - 5	4.09	14 - 8	4.47
D	7 - 5	2.26	8 - 3	2.51
E	15 - 1	4.60	15 - 1	4.60
F	7 - 5	2.26	8 - 3	2.51
G	7 - 6	2.29	8 - 6	2.59
H	13 - 4	4.06	14 - 6	4.42
J	51 - 2	15.60	52 - 11	16.13
K	2 - 8	0.81	3 - 7	1.09
L	16 - 3	4.95	18 - 3	5.56
M	12 - 9	3.89	14 - 3	4.34
N	19 - 6	5.94	21 - 7	6.58

NOTES:

1. VERTICAL CLEARANCES SHOWN OCCUR DURING MAXIMUM VARIATIONS OF AIRPLANE ATTITUDE. COMBINATIONS OF AIRPLANE LOADING AND UNLOADING ACTIVITIES THAT PRODUCE THE GREATEST POSSIBLE VARIATIONS IN ATTITUDE WERE USED TO ESTABLISH THE VARIATIONS SHOWN.
 2. DURING ROUTINE SERVICING, THE AIRPLANE REMAINS RELATIVELY STABLE, PITCH AND ELEVATION CHANGES OCCURRING SLOWLY.
- * NOMINAL DIMENSIONS

D6-58328

REV I

July 2021

2-12

2.3.2 Ground Clearances: Model 767-300, -300ER

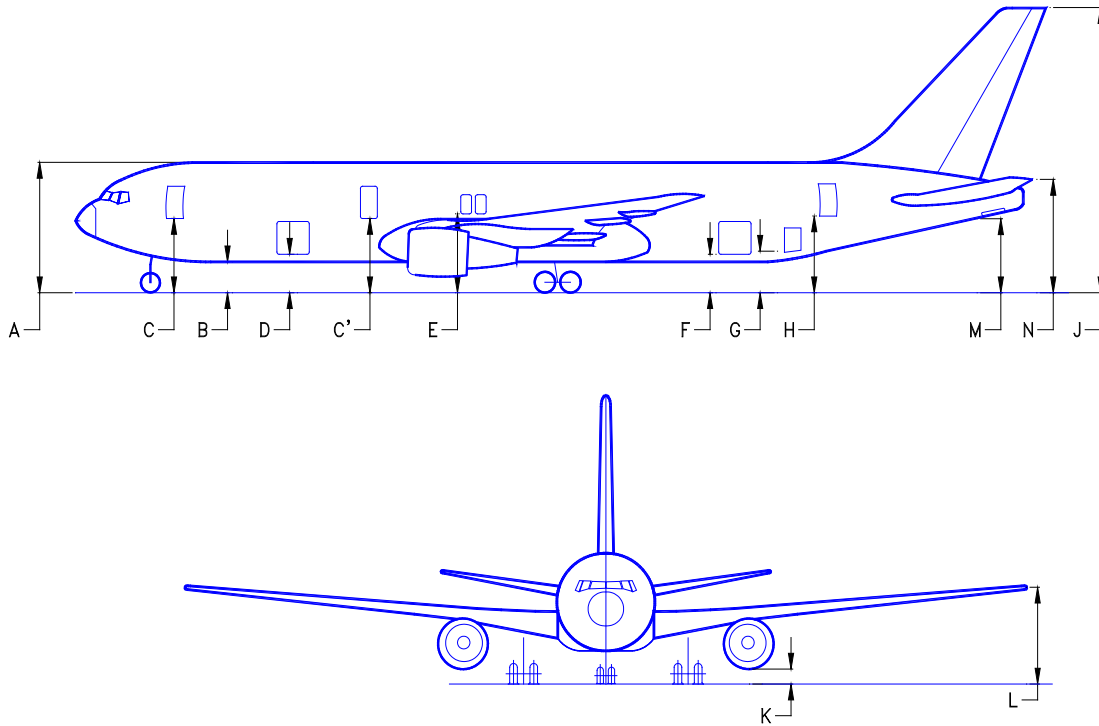

Dimension	MINIMUM		MAXIMUM	
	FEET - INCHES	METERS	FEET - INCHES	METERS
A	23 - 7	7.19	24 - 7	7.49
B	5 - 10	1.78	6 - 10	2.08
C	13 - 7	4.14	14 - 9	4.50
C'	13 - 8	4.16	14 - 8	4.47
D	7 - 6	2.29	8 - 5	2.57
E	15 - 1	4.60	15 - 8	4.77
F	7 - 2	2.18	8 - 3	2.51
G	7 - 3	2.21	8 - 6	2.59
H	13 - 1	3.99	14 - 5	4.39
J	50 - 6	15.39	52 - 7	16.03
K	1 - 10	0.56	3 - 8	1.12
L	16 - 1	4.90	17 - 11	5.46
M	12 - 2	3.71	14 - 1	4.29

NOTES:

1. VERTICAL CLEARANCES SHOWN OCCUR DURING MAXIMUM VARIATIONS OF AIRPLANE ATTITUDE. COMBINATIONS OF AIRPLANE LOADING AND UNLOADING ACTIVITIES THAT PRODUCE THE GREATEST POSSIBLE VARIATIONS IN ATTITUDE WERE USED TO ESTABLISH THE VARIATIONS SHOWN.
 2. DURING ROUTINE SERVICING, THE AIRPLANE REMAINS RELATIVELY STABLE, PITCH AND ELEVATION CHANGES OCCURRING SLOWLY.
- * NOMINAL DIMENSIONS

D6-58328

REV I

July 2021

2-13

2.3.3 Ground Clearances: Model 767-300 Freighter

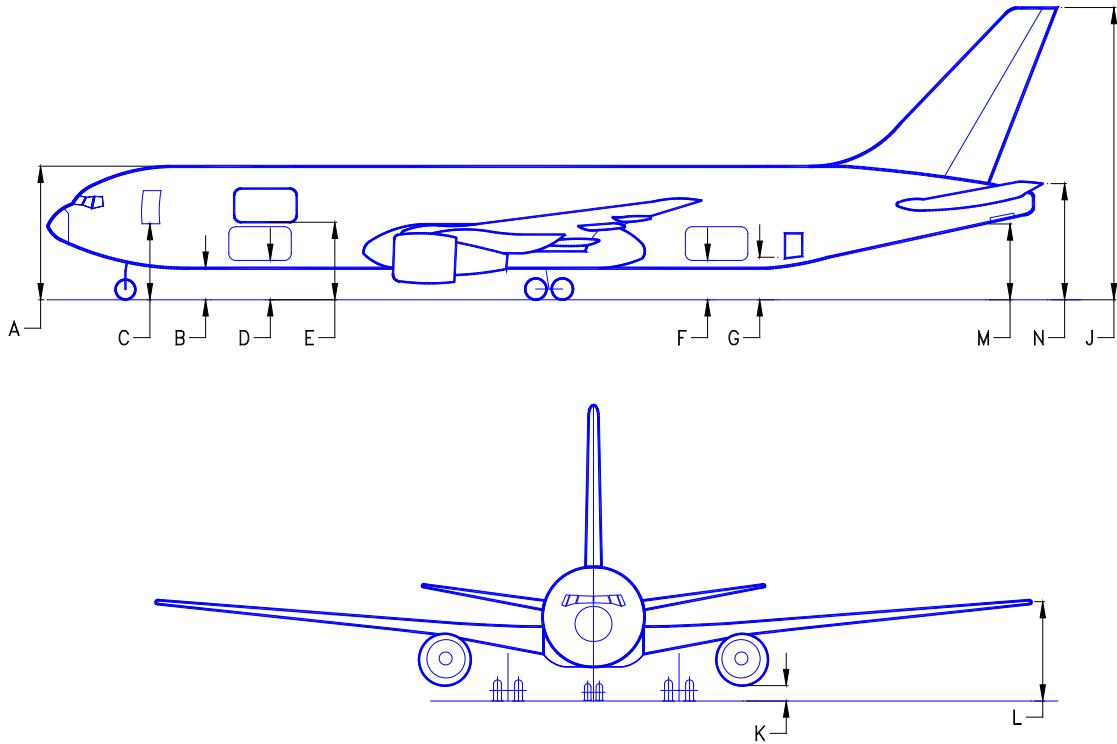

Dimension	MINIMUM		MAXIMUM	
	FEET - INCHES	METERS	FEET - INCHES	METERS
A	23 - 6	7.16	24 - 7	7.49
B	5 - 10	1.78	6 - 10	2.08
C	13 - 6	4.11	14 - 9	4.50
D	7 - 5	2.26	8 - 5	2.57
E	13 - 8	4.16	14 - 8	4.47
F	7 - 5	2.26	8 - 4	2.54
G	7 - 5	2.26	8 - 7	2.62
J	50 - 8	15.44	52 - 11	16.13
K	1 - 10	0.56	3 - 7	1.09
L	16 - 3	4.95	18 - 3	5.56
M	12 - 3	3.73	14 - 4	4.37
N	19 - 4	5.89	21 - 7	6.58
A	23 - 6	7.16	24 - 7	7.49

NOTES:

1. VERTICAL CLEARANCES SHOWN OCCUR DURING MAXIMUM VARIATIONS OF AIRPLANE ATTITUDE. COMBINATIONS OF AIRPLANE LOADING AND UNLOADING ACTIVITIES THAT PRODUCE THE GREATEST POSSIBLE VARIATIONS IN ATTITUDE WERE USED TO ESTABLISH THE VARIATIONS SHOWN.
 2. DURING ROUTINE SERVICING, THE AIRPLANE REMAINS RELATIVELY STABLE, PITCH AND ELEVATION CHANGES OCCURRING SLOWLY.
- * NOMINAL DIMENSIONS

2.3.4 Ground Clearances: Model 767-400ER

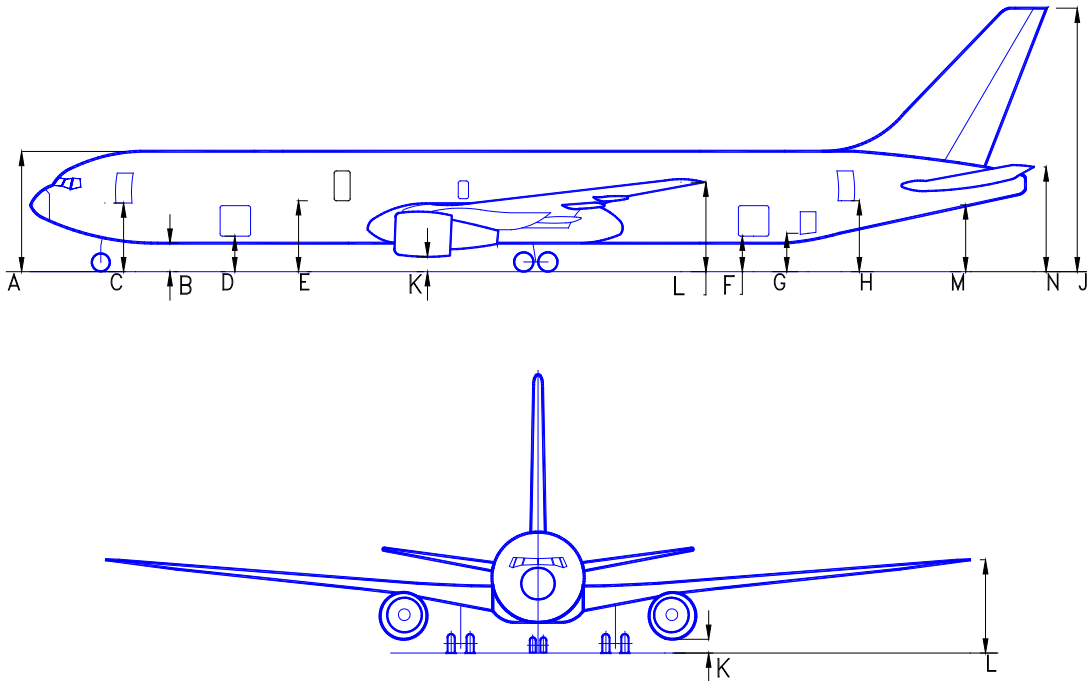

Dimension	MINIMUM		MAXIMUM	
	FEET – INCHES	METERS	FEET – INCHES	METERS
A	23-8	7.22	24-6	7.46
B	5-11	1.81	6-9	2.05
C	13-7	4.13	14-5	4.39
D	7-10	2.38	8-7	2.61
E	14-6	4.41	15-1	4.59
F	9-8	2.96	10-6	3.20
G	10-1	3.07	10-11	3.33
H	16-1	4.91	17-0	5.18
J	54-9	16.68	55-10	17.01
K	3-11	1.21	4-5	1.36
L	19-11	6.08	21-4	6.51
M	16-4	4.89	17-1	5.22
N	23-5	7.12	24-5	7.45

NOTES:

1. VERTICAL CLEARANCES SHOWN OCCUR DURING MAXIMUM VARIATIONS OF AIRPLANE ATTITUDE. COMBINATIONS OF AIRPLANE LOADING AND UNLOADING ACTIVITIES THAT PRODUCE THE GREATEST POSSIBLE VARIATIONS IN ATTITUDE WERE USED TO ESTABLISH THE VARIATIONS SHOWN.
 2. DURING ROUTINE SERVICING, THE AIRPLANE REMAINS RELATIVELY STABLE, PITCH AND ELEVATION CHANGES OCCURRING SLOWLY.
- * NOMINAL DIMENSIONS

D6-58328

REV I

July 2021

2-15

2.4 INTERIOR ARRANGEMENTS

2.4.1 Typical Interior Arrangements: Model 767-200, -200ER, Mixed Class

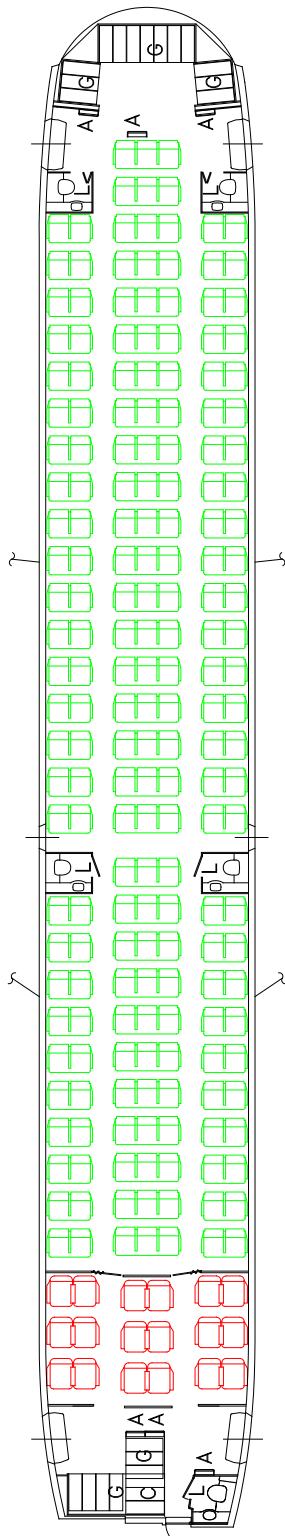

216 SEATS

- 18 FIRST CLASS AT 38-IN (0.97 M) PITCH
- 198 ECONOMY CLASS AT 34-IN (0.86 M) PITCH

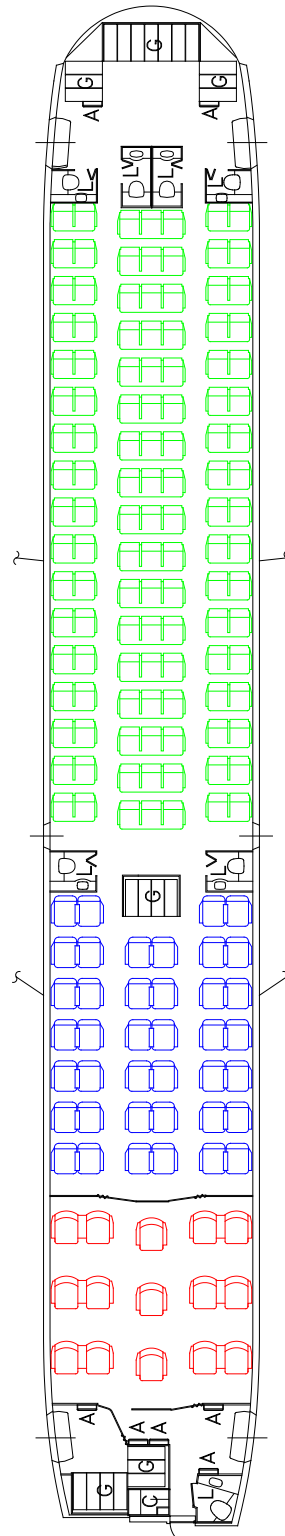

174 SEATS

- 15 FIRST CLASS AT 60-IN (1.53 M) PITCH
- 40 BUSINESS CLASS AT 38-IN (0.97 M) PITCH
- 119 ECONOMY CLASS AT 34-IN (0.86 M) PITCH

A ATTENDANT
C CLOSET
G GALLEY
L LAVATORY

2.4.2 Typical Interior Arrangements: Model 767-200, -200ER, All-Economy Class

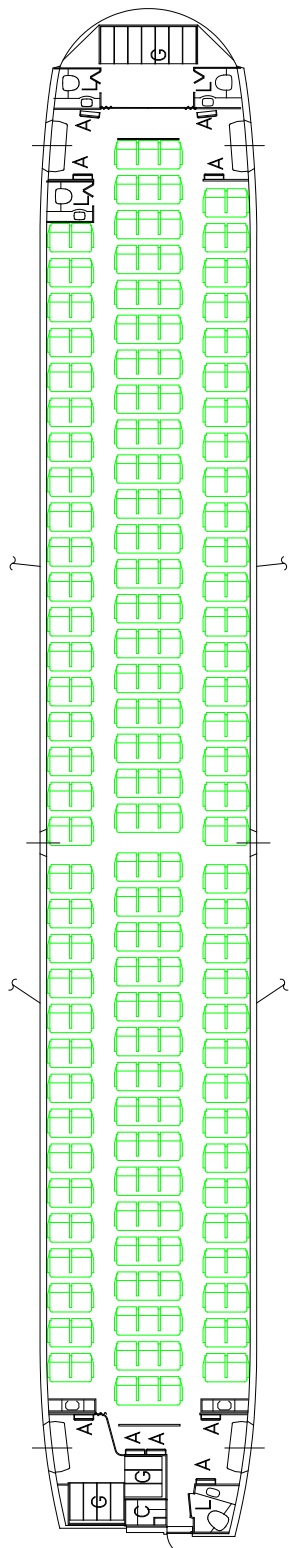

242 SEATS
 ● 242 ECONOMY CLASS AT 32-IN (0.81 M) PITCH

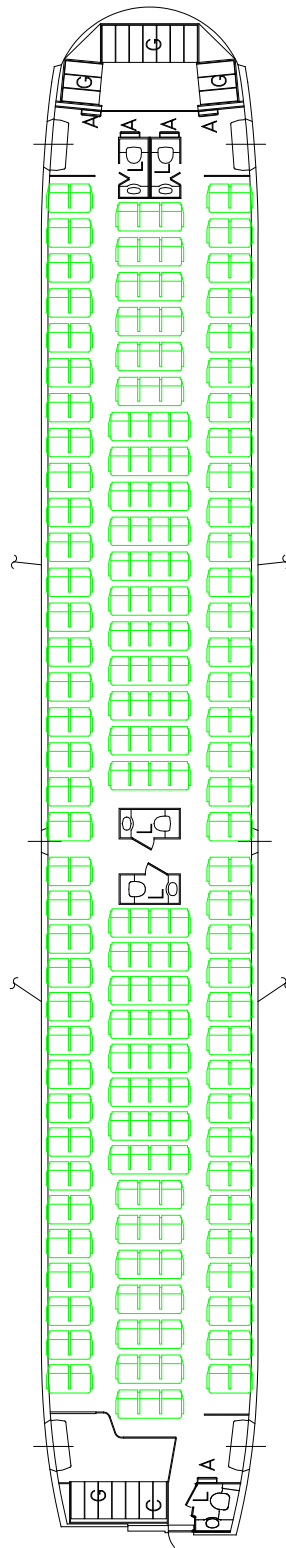

245 SEATS
 ● 245 ECONOMY CLASS AT 31-IN (0.79 M) PITCH

- A ATTENDANT
- C CLOSET
- G GALLEY
- L LAVATORY

2.4.3 Typical Interior Arrangements: Model 767-300, -300ER, Mixed Class

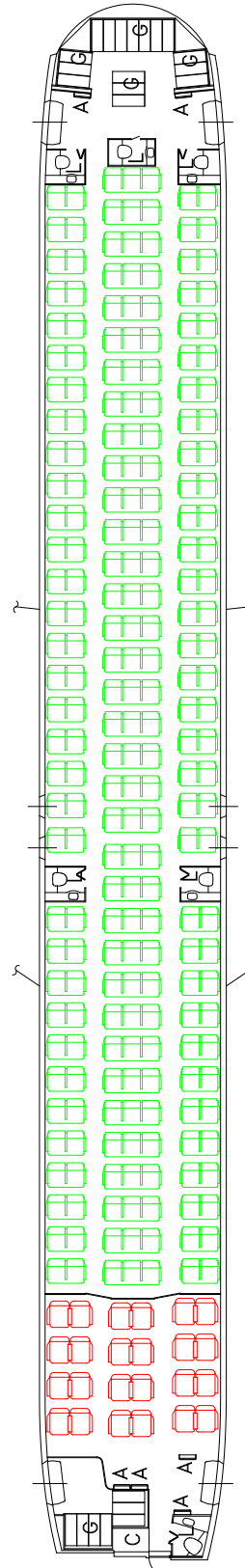
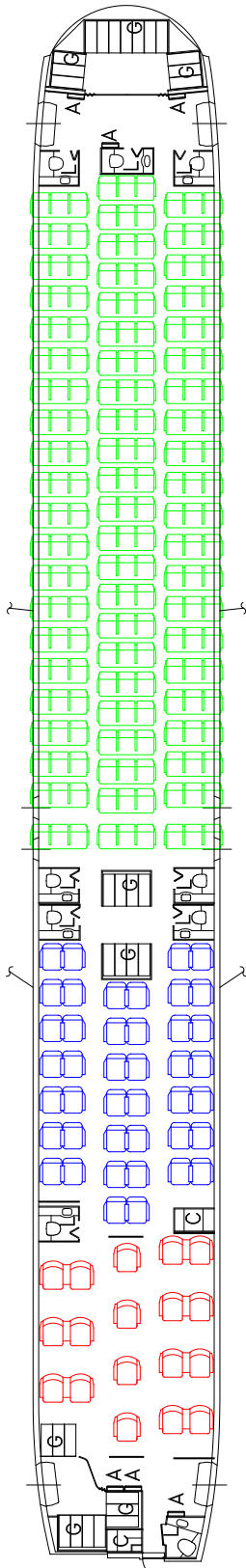

A ATTENDANT
C CLOSET
G GALLEY
L LAVATORY

D6-58328

REV I

July 2021

2-18

2.4.4 Typical Interior Arrangements: Model 767-300, -300ER, Mixed Class, Type A Door Option

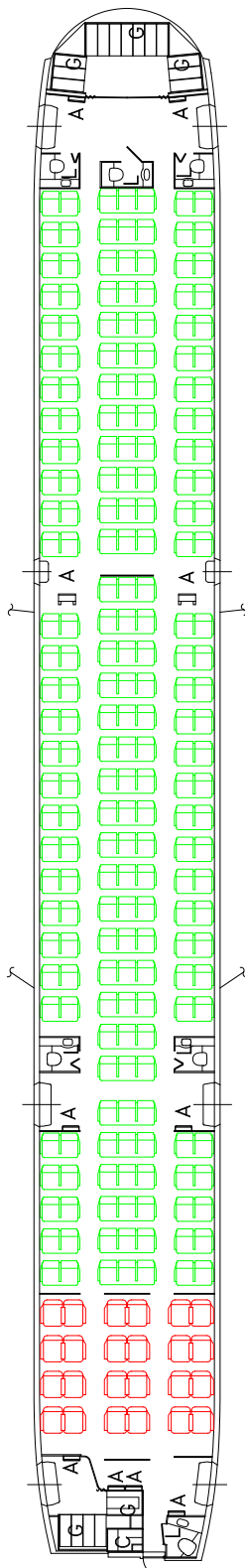

- 248 SEATS
- 24 FIRST CLASS AT 38-IN (0.97 M) PITCH
 - 224 ECONOMY CLASS AT 34-IN (0.86 M) PITCH

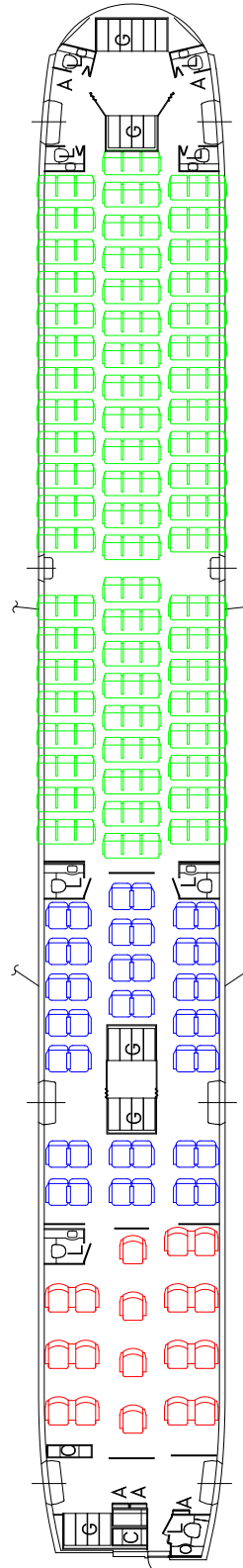

- 204 SEATS
- 18 FIRST CLASS AT 60-IN (1.52 M) PITCH
 - 40 BUSINESS CLASS AT 38-IN (0.97 M) PITCH
 - 146 ECONOMY CLASS AT 34-IN (0.86 M) PITCH
- A ATTENDANT
C CLOSET
G GALLEY
L LAVATORY

2.4.5 Typical Interior Arrangements: Model 767-300, -300ER, All-Economy Class

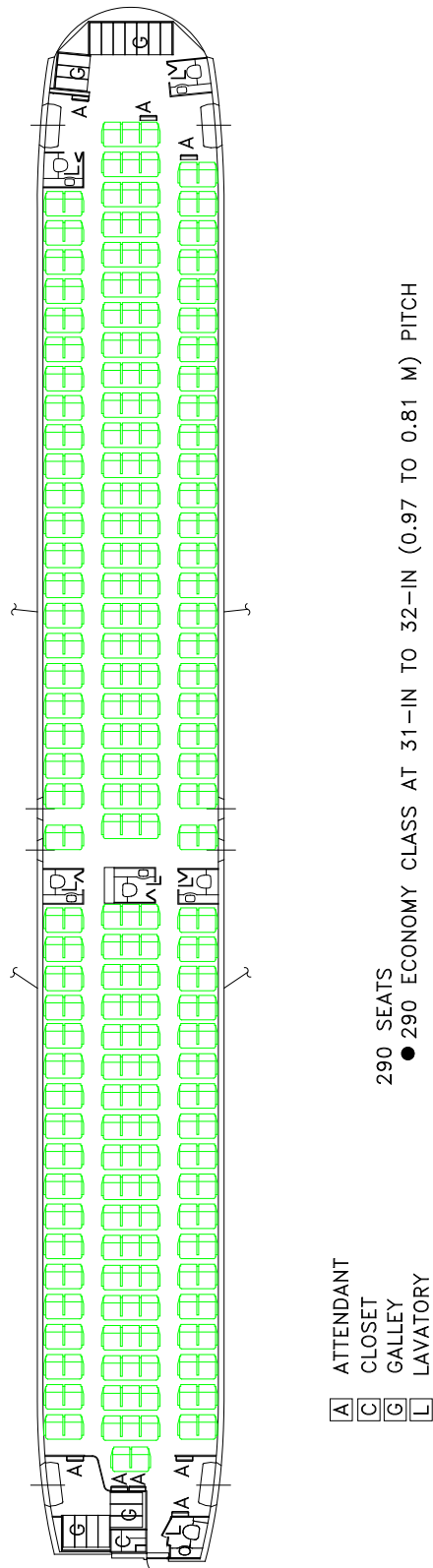

2.4.6 Typical Interior Arrangements: Model 767-300 Freighter, Main Deck Cargo

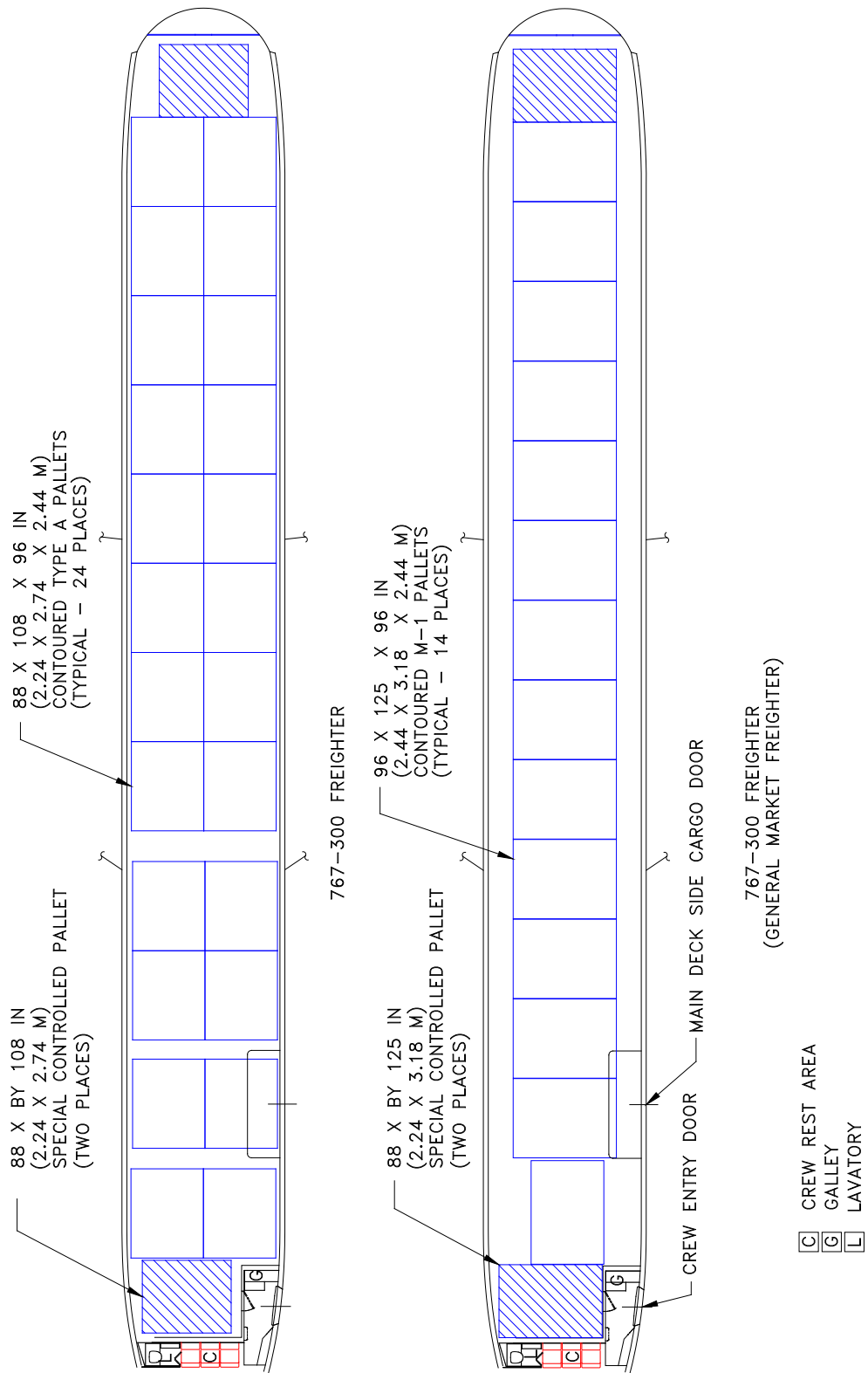

D6-58328

REV I

July 2021

2-21

2.4.7 Typical Interior Arrangements: Model 767-400ER

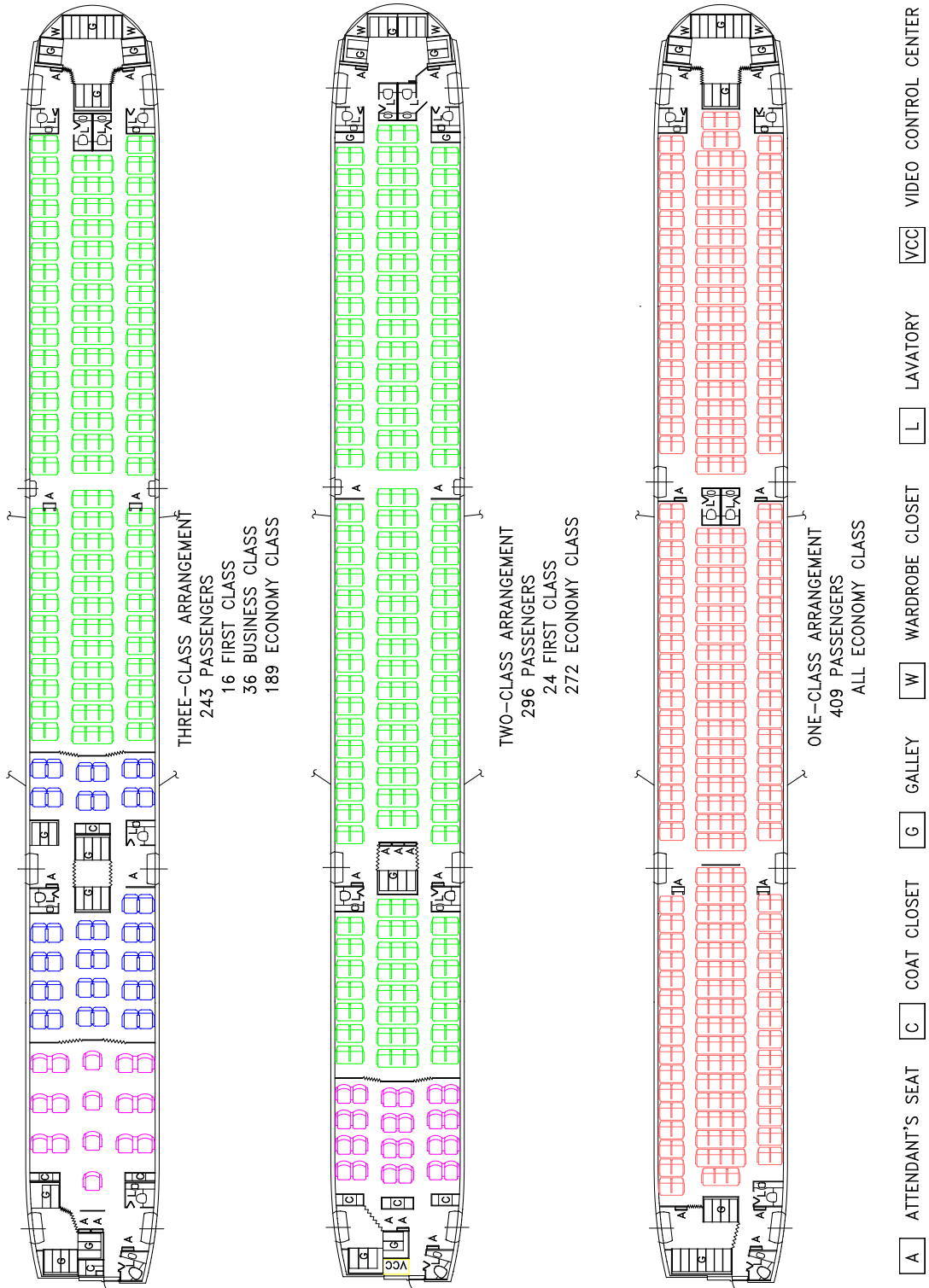

D6-58328

REV I

July 2021

2-22

2.5 CABIN CROSS SECTIONS

2.5.1 Cabin Cross-Sections: Model 767-200, -200ER, -300, -300ER, -400ER, Economy Class

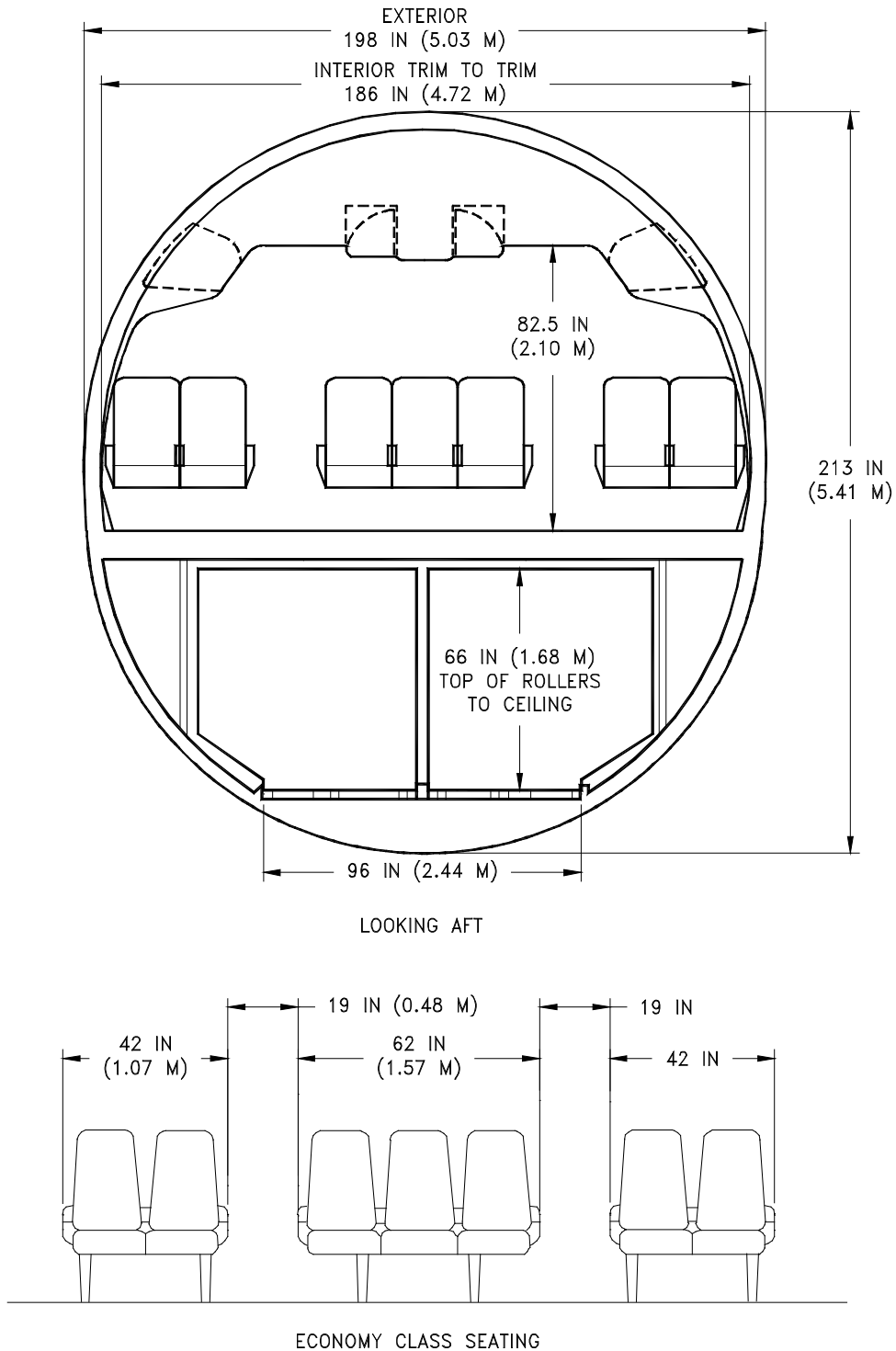

D6-58328

July 2021

REV I

2-23

2.5.2 Cabin Cross-Sections: Model 767-200, -200ER, -300, -300ER, -400ER, Alternate Seating

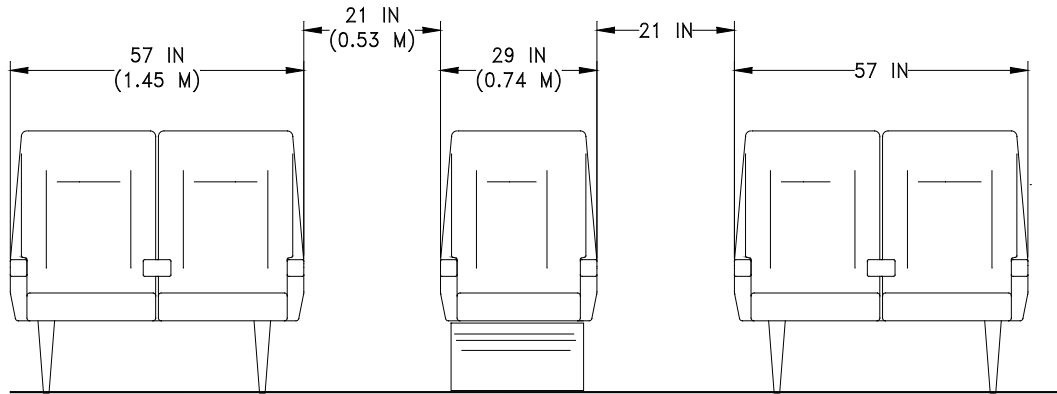

PREMIUM SLEEPER SEATS

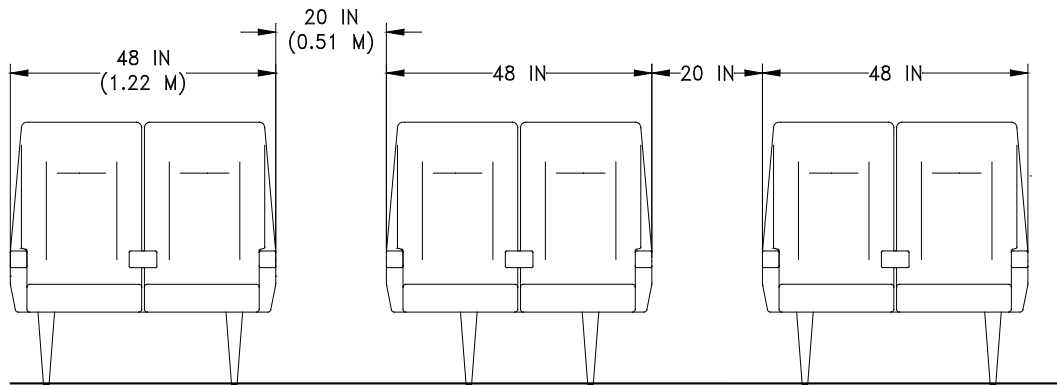

BUSINESS CLASS SEATING
SIX-ABREAST

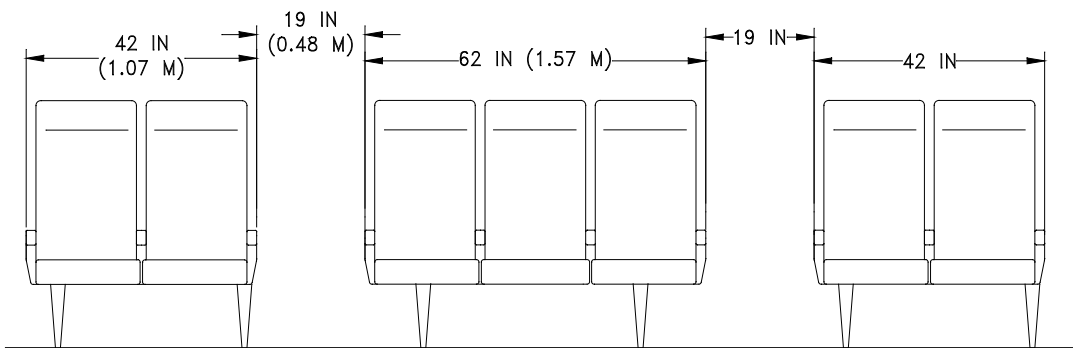

PREMIUM ECONOMY CLASS SEATING
SEVEN-ABREAST

2.6 LOWER CARGO COMPARTMENTS

2.6.1 Lower Cargo Compartments: Model 767-200, -200ER, LD-2 Containers and Bulk Cargo

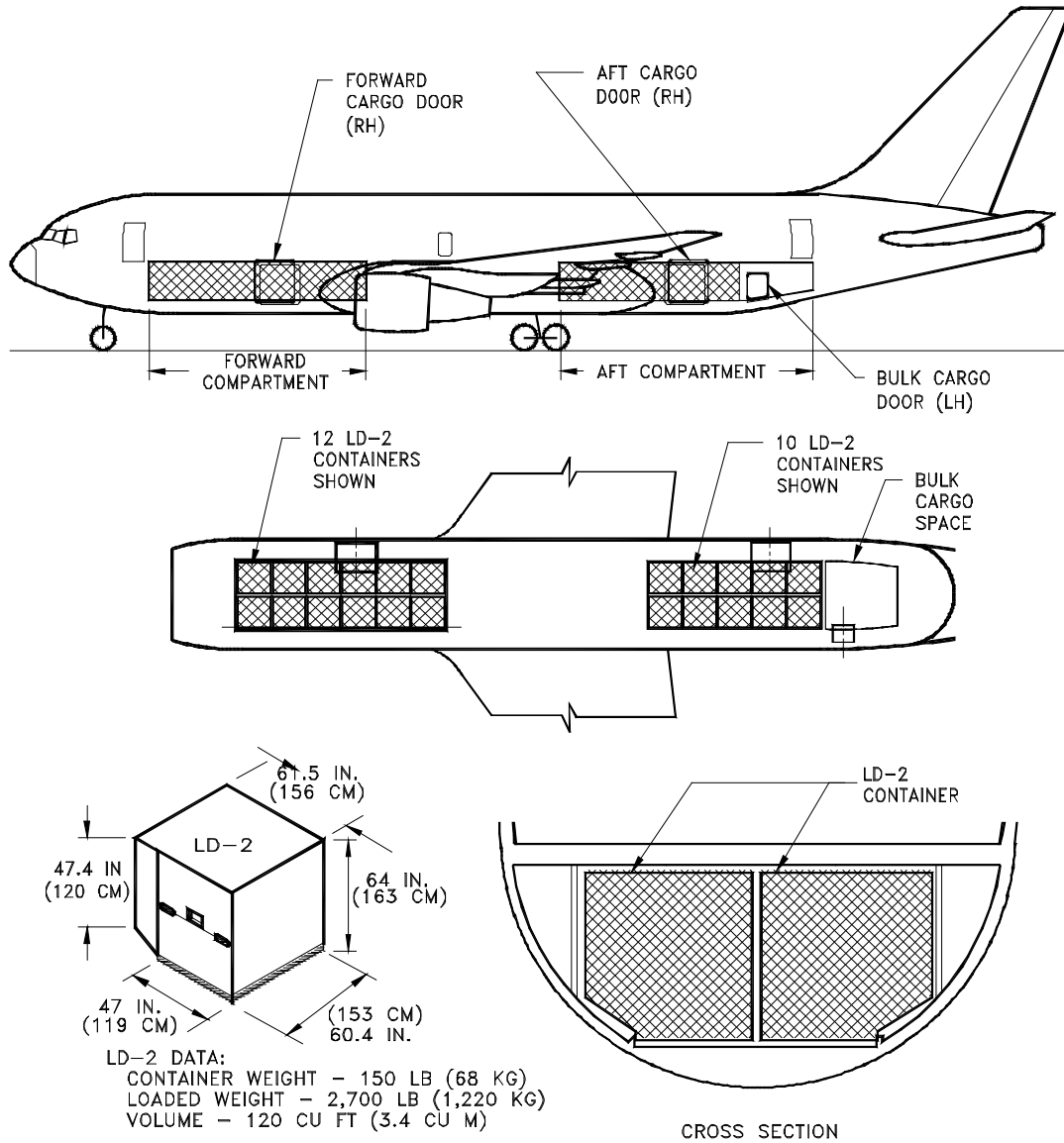

		FWD COMPARTMENT	AFT COMPARTMENT		TOTAL
		12 LD-2 CONTAINERS	10 LD-2 CONTAINERS	BULK CARGO	
VOLUME	CUBIC FEET	1,440	1,200	430	3,070
	CUBIC METERS	40.78	33.98	12.18	86.94

STRUCTURAL WEIGHT LIMIT

SEVEN-ABREAST SEATING	POUNDS	33,750	27,000	6,450	67,200
	KILOGRAMS	15,309	12,247	2,926	30,481
EIGHT-ABREAST SEATING	POUNDS	21,600	18,000	6,450	46,050
	KILOGRAMS	9,798	8,165	2,926	20,888

2.6.2 Lower Cargo Compartments: Model 767-200, -200ER, Alternate

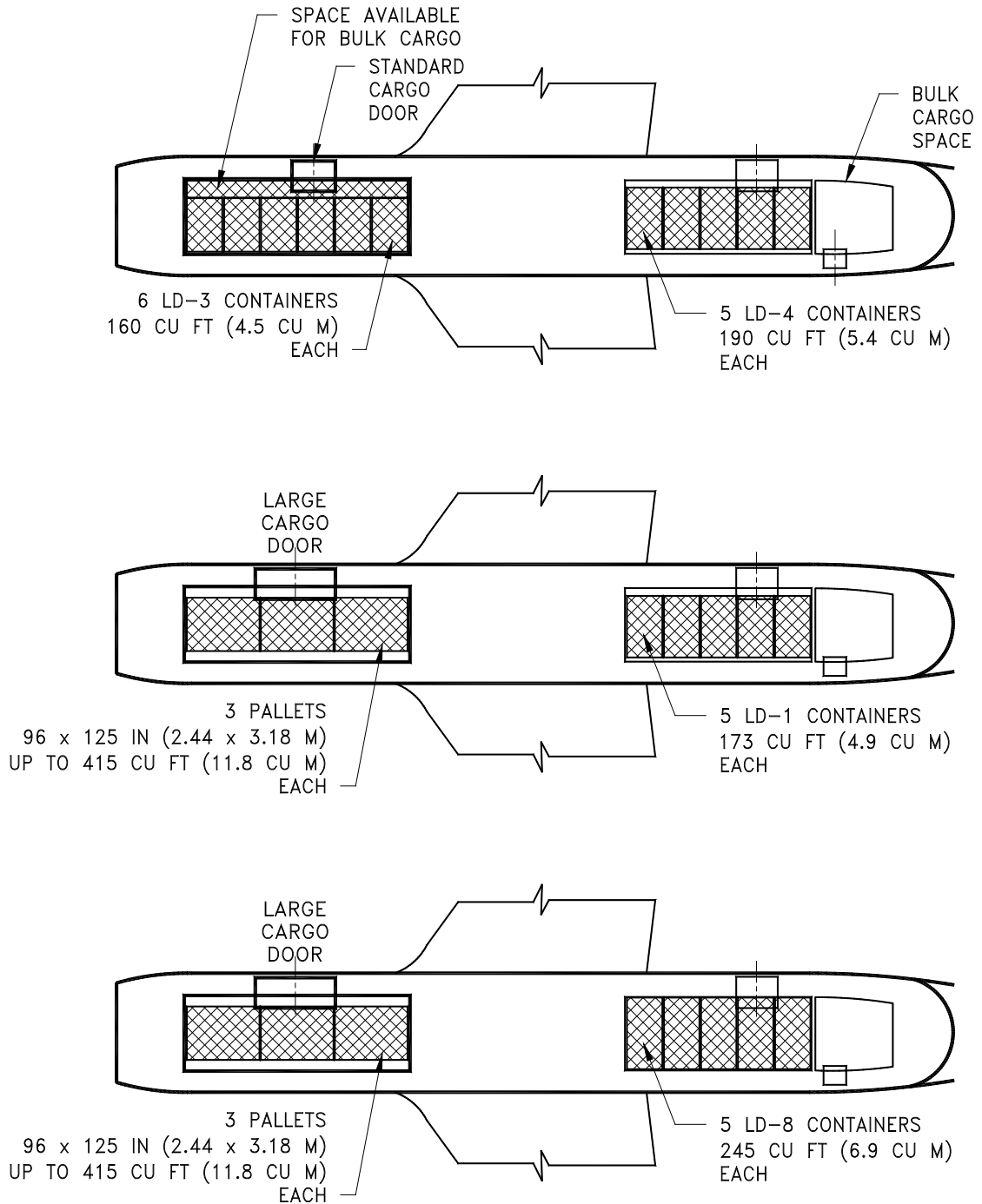

D6-58328

REV I

July 2021

2-26

2.6.3 Lower Cargo Compartments: Model 767-300, -300ER, -300 Freighter, LD-2 Containers and Bulk Cargo

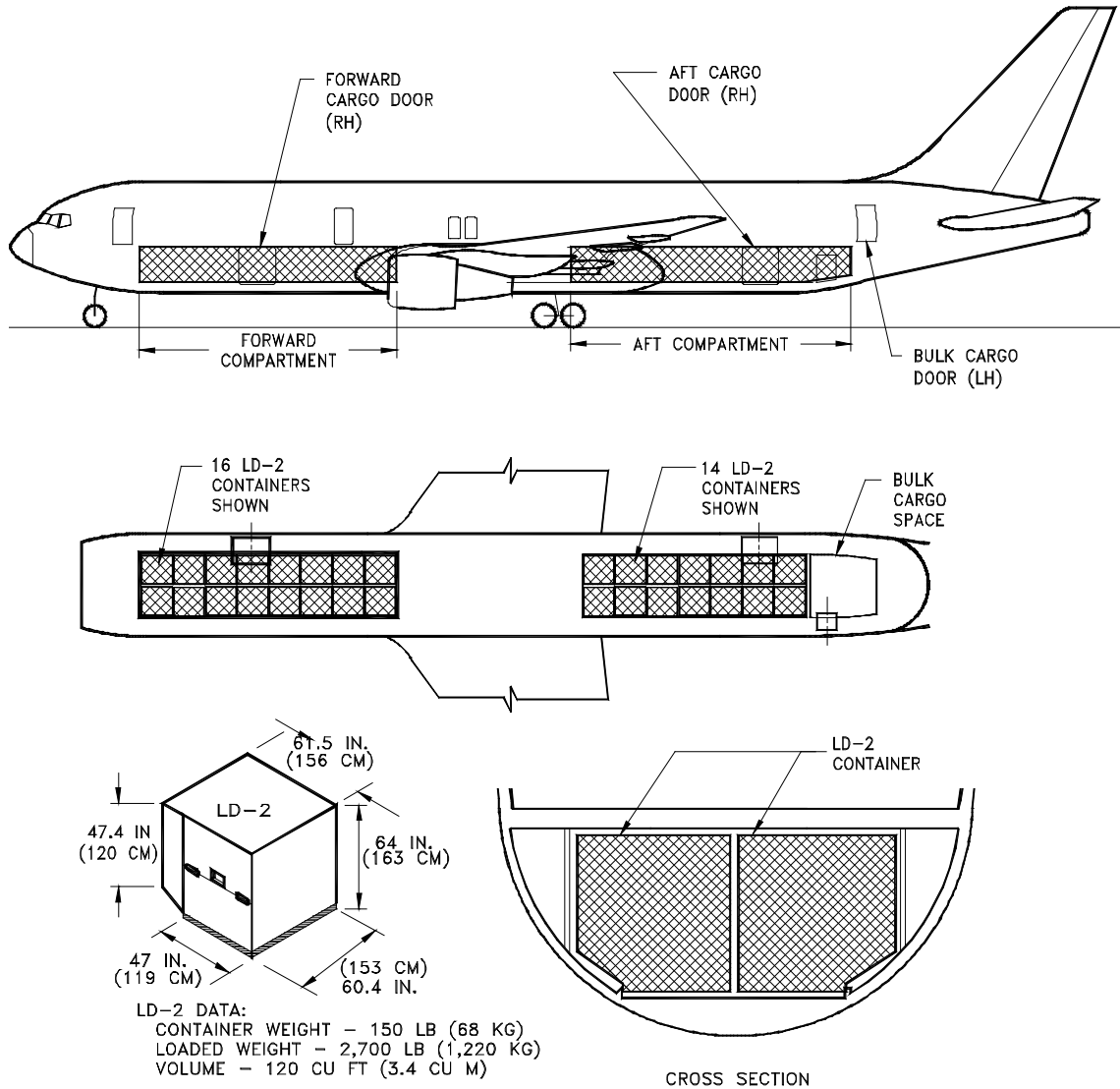

LD-2 DATA:
 CONTAINER WEIGHT - 150 LB (68 KG)
 LOADED WEIGHT - 2,700 LB (1,220 KG)
 VOLUME - 120 CU FT (3.4 CU M)

		FWD COMPARTMENT		AFT COMPARTMENT		TOTAL
		16 LD-2 CONTAINERS	14 LD-2 CONTAINERS	BULK CARGO		
VOLUME	CUBIC FEET	1,920	1,680	430	4,030	
	CUBIC METERS	54.4	47.6	12.2	114.2	

STRUCTURAL WEIGHT LIMIT					
SEVEN-ABREAST SEATING	POUNDS	45,000	37,800	6,450	89,250
	KILOGRAMS	20,412	17,146	2,926	40,483
EIGHT-ABREAST SEATING	POUNDS	28,800	25,200	6,450	60,450
	KILOGRAMS	13,063	11,431	2,926	27,420

2.6.4 Lower Cargo Compartments: Model 767-300, -300ER, -300 Freighter, LD-2 Containers and Bulk Cargo

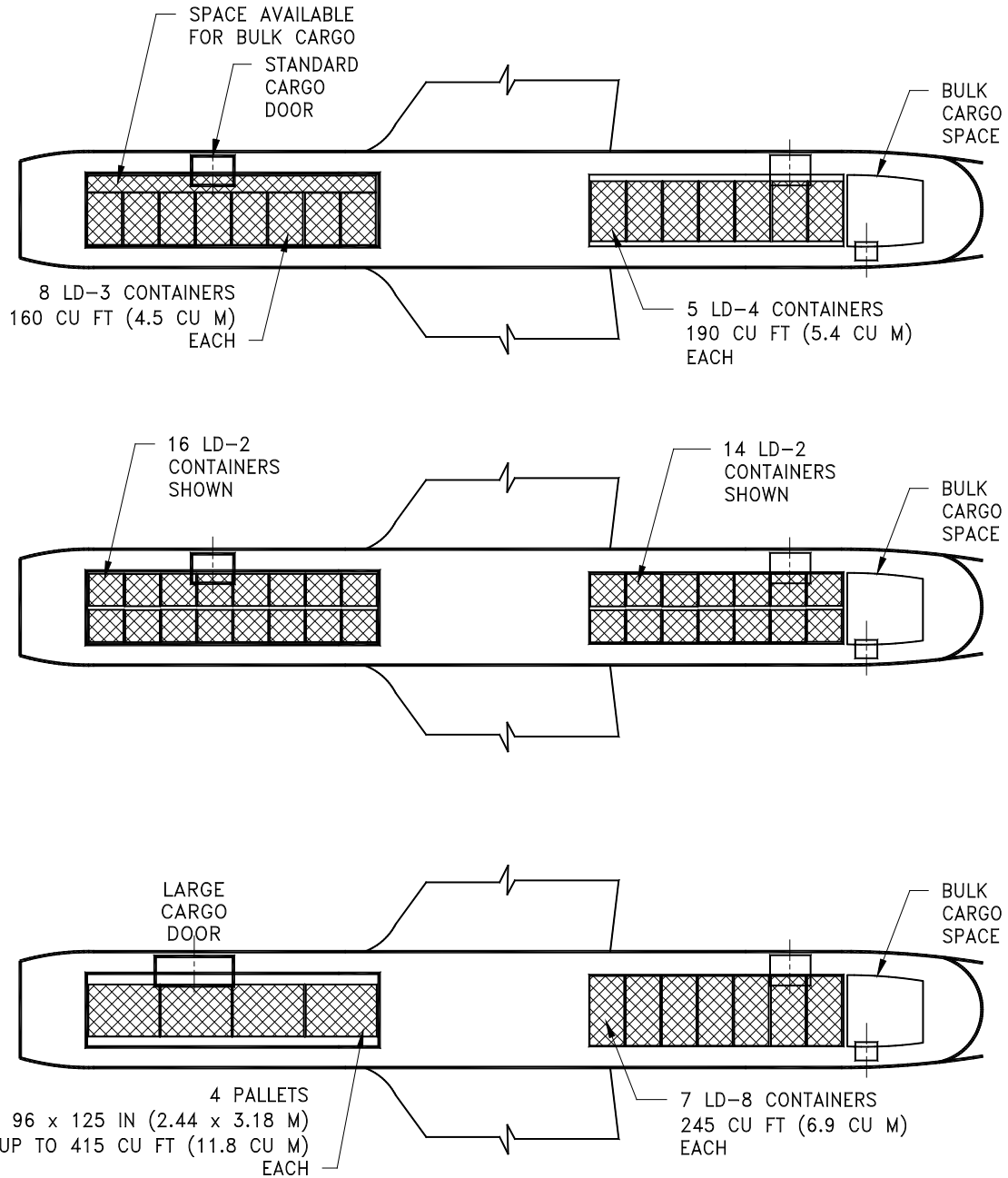

D6-58328

2.6.5 Lower Cargo Compartments: Model 767-400ER, Containers and Bulk Cargo

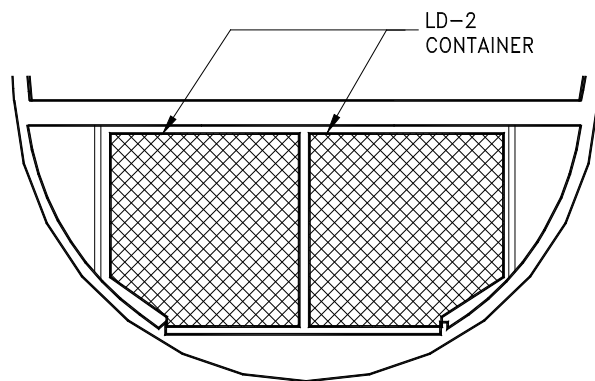
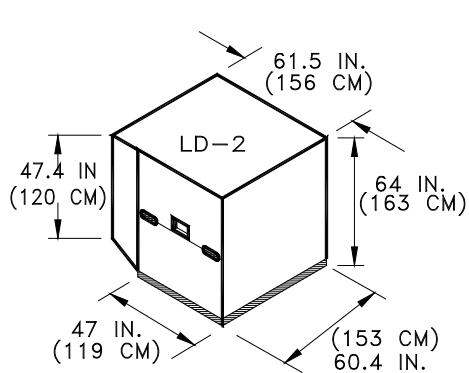
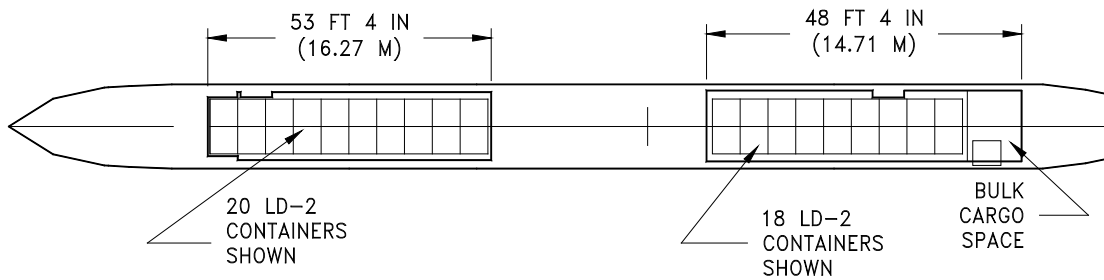
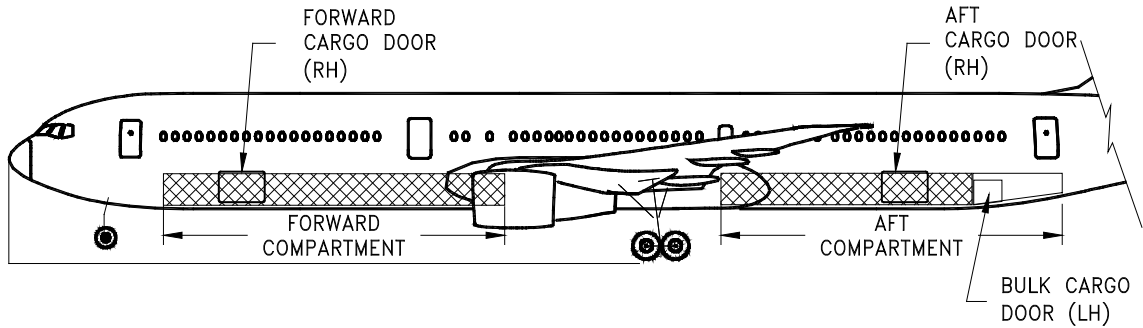

2.7 DOOR CLEARANCES

2.7.1 Door Clearances: Model 767-200, -200ER, -300, -300ER, -300 Freighter, -400ER, Passenger and Service Doors

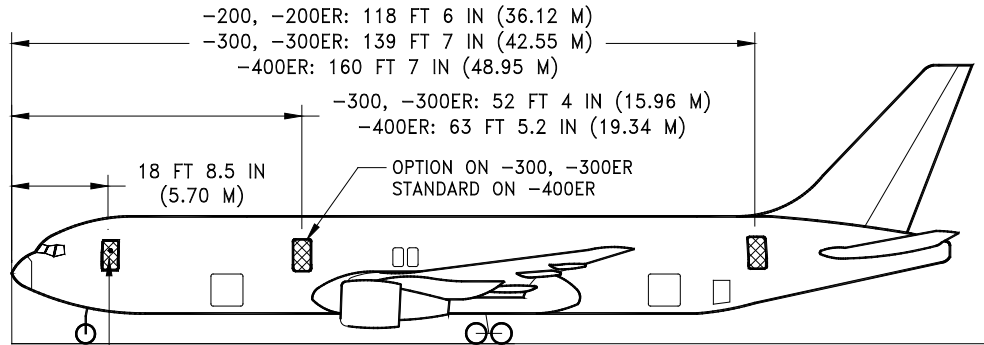

PASSENGER DOOR
 LH SIDE TWO OR THREE PLACES
 FWD LH SIDE ONLY ON -300 FREIGHTER
 42 BY 74 IN
 (1.07 BY 1.88 M)

SERVICE DOOR
 RH SIDE TWO OR THREE PLACES
 42 X 72 IN
 (1.07 BY 1.83 M)

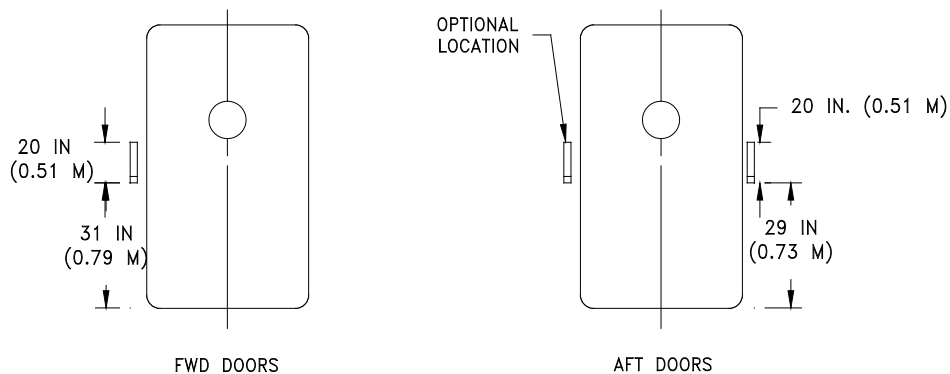
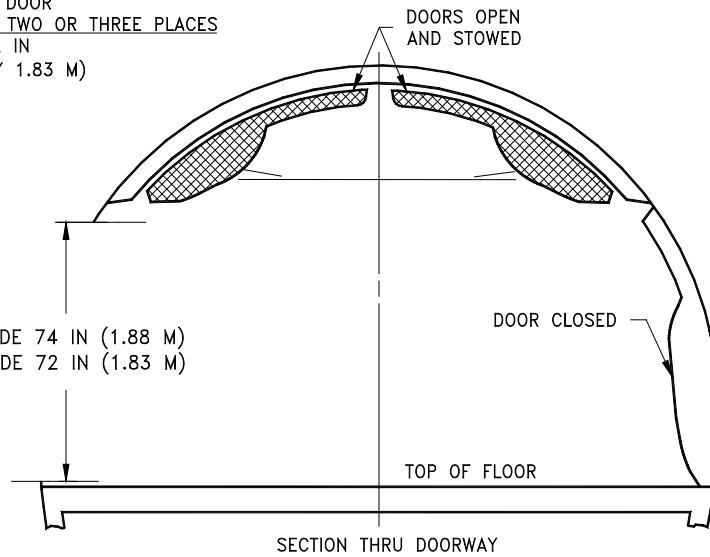

DOOR HANDLE LOCATIONS--LH EXTERIOR VIEW SHOWN--RH IS OPPOSITE

2.7.2 Door Clearances: Model 767-200, -200ER, -300, -300ER, -300 Freighter, -400ER, Locations of Probes and Sensors Near Main Entry Door No. 1

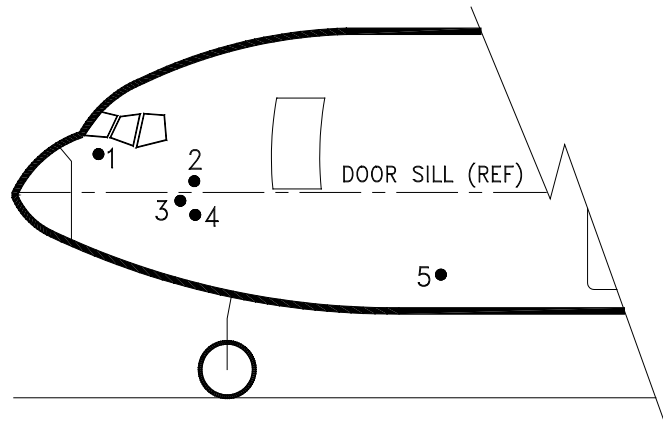

LEFT SIDE VIEW

NO	SENSOR	AFT OF NOSE		ABOVE DOOR SILL		BELOW DOOR SILL	
		FT-IN	M	FT-IN	M	FT-IN	M
1	TOTAL AIR TEMPERATURE (LH SIDE ONLY)	4-3	1.39	2-4	0.71	-	-
2	PITOT STATIC PROBE (LH AND RH SIDES)	9-0	2.74	1-0	0.30	-	-
3	ANGLE OF ATTACK (LH AND RH SIDES)	8-3	2.51	-	-	0-2	0.05
4	PITOT STATIC PROBES (LH AND RH SIDES)	9-0	2.74	-	-	0-6	0.15
5	FLUSH STATIC PORT (LH AND RH SIDES)	31-0	9.45	-	-	5-0	1.52

2.7.3 Door Clearances: Model 767-200, -200ER, -300, -300ER, Standard Forward Cargo Door

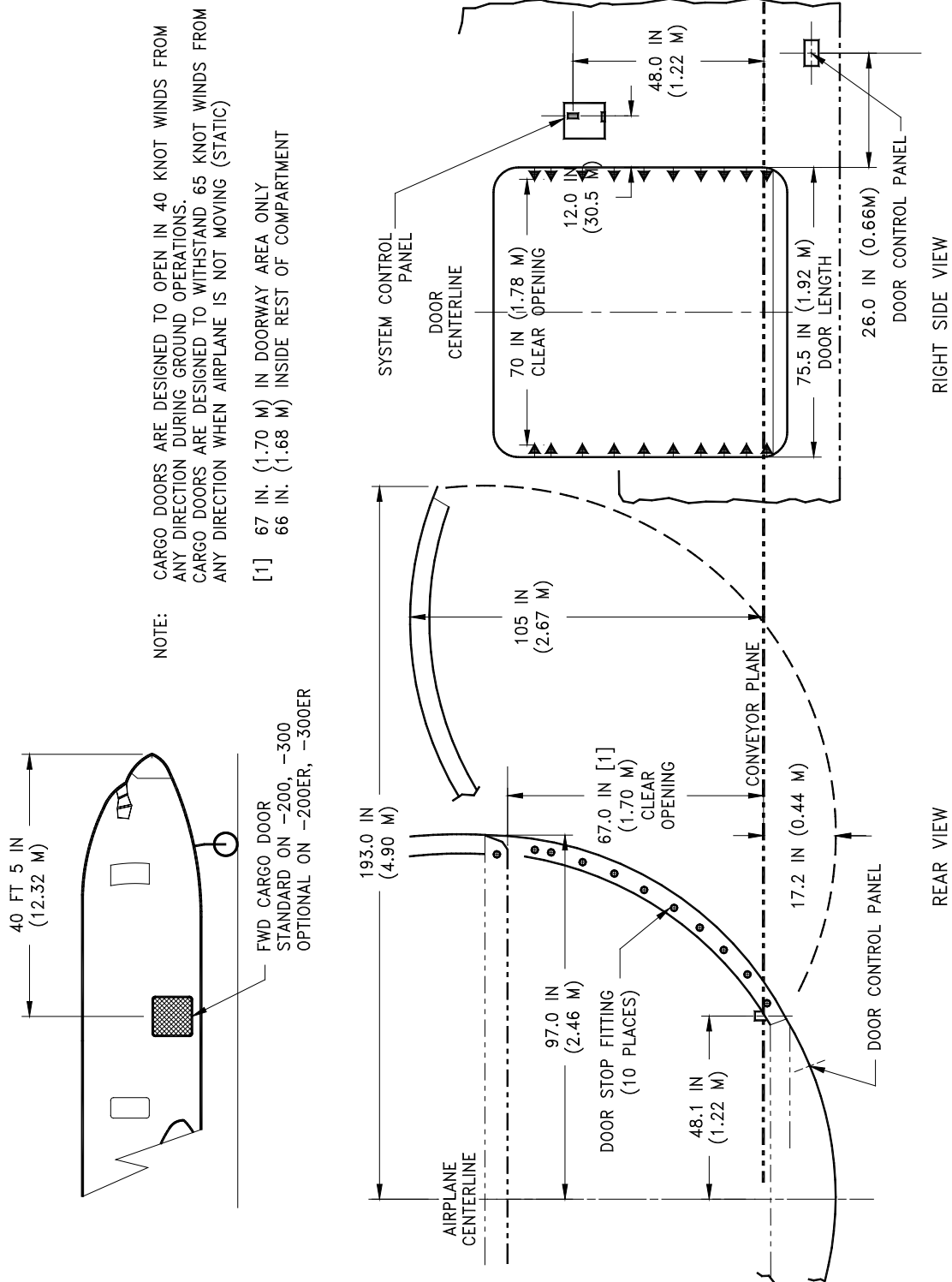

D6-58328

2.7.4 Door Clearances: Model 767-200, -200ER, -300, -300ER, -300 Freighter, -400ER, Large Forward Cargo Door

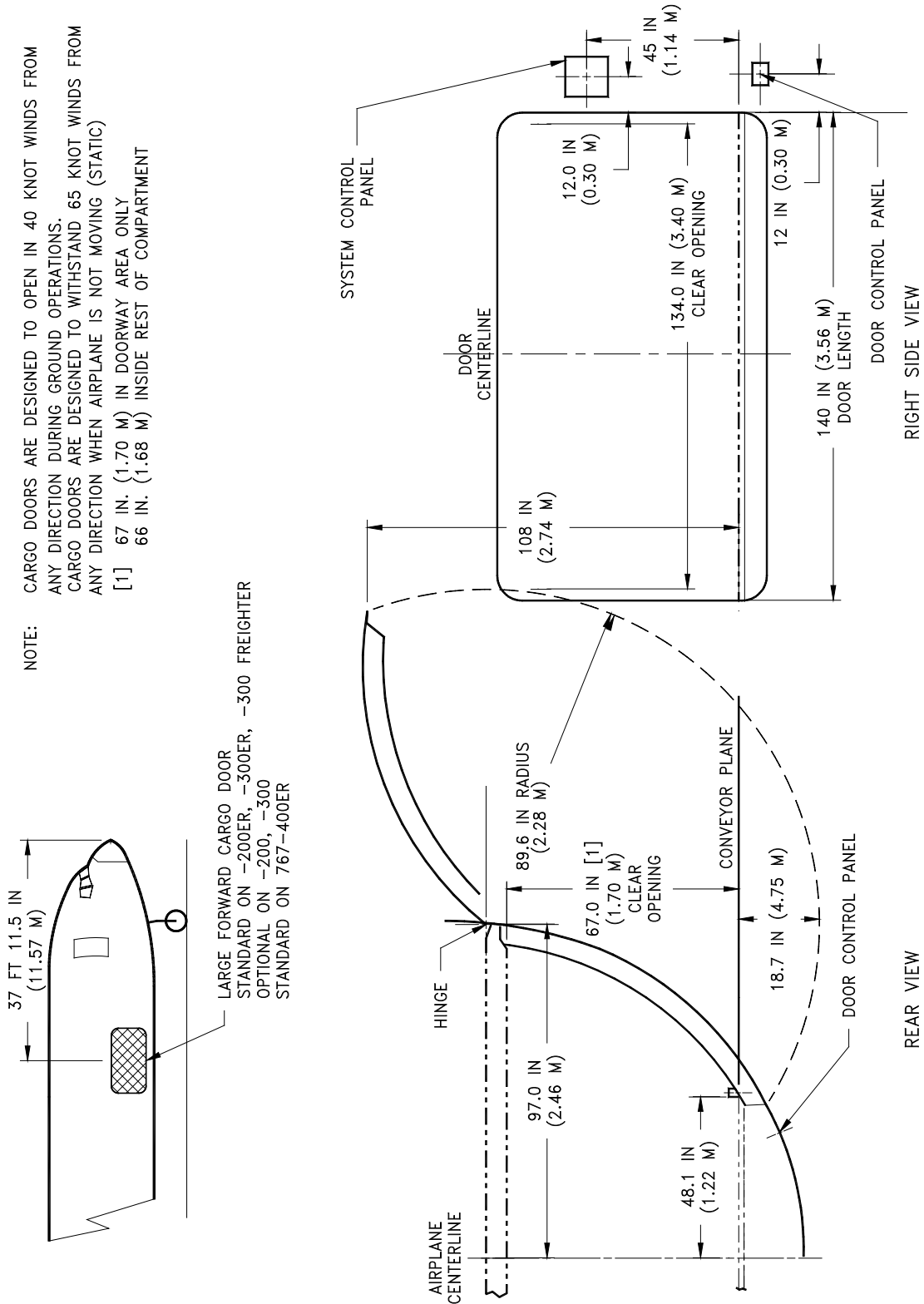

2.7.5 Door Clearances: Model 767-200, -200ER, -300, -300ER, -300 Freighter, -400ER, Aft Cargo Door

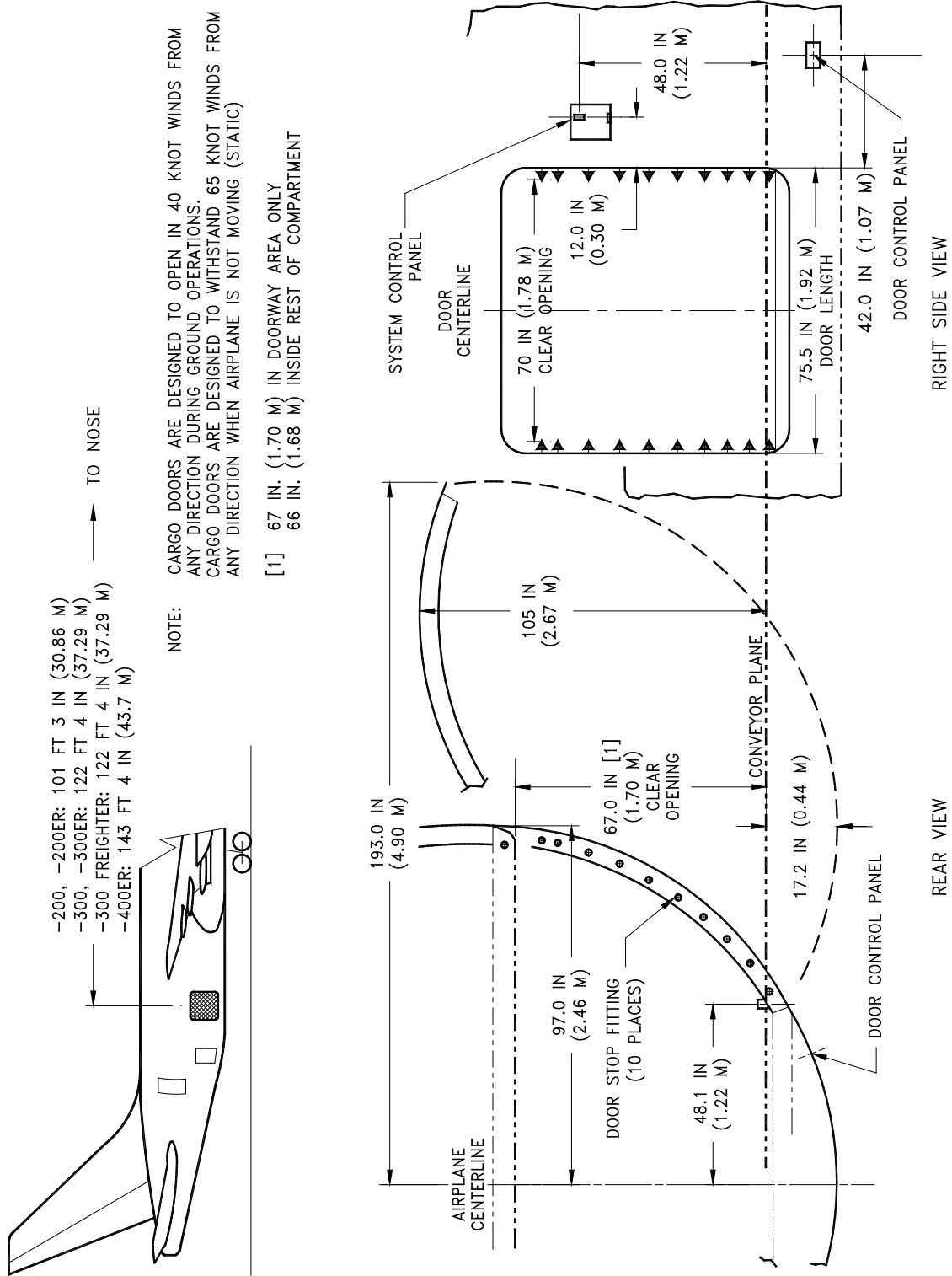

2.7.6 Door Clearances: Model 767-200, -200ER, -300, -300ER, -300 Freighter, -400ER, Bulk Cargo Door

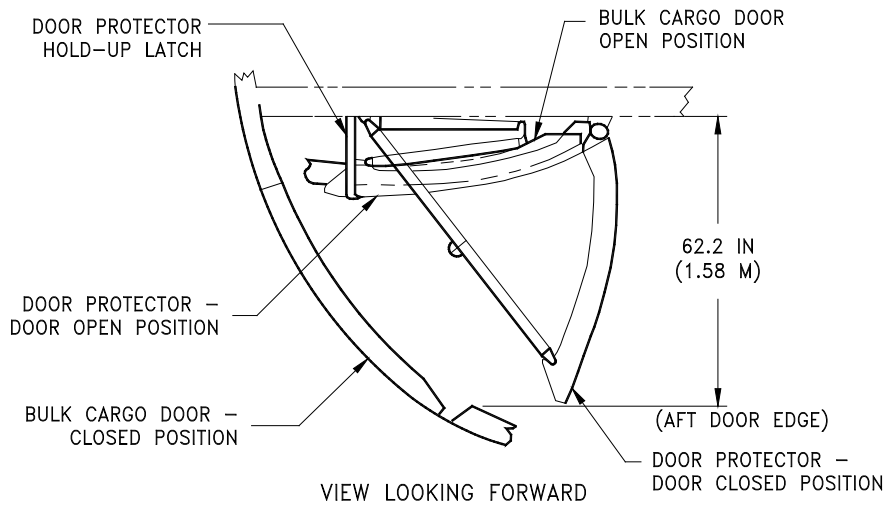
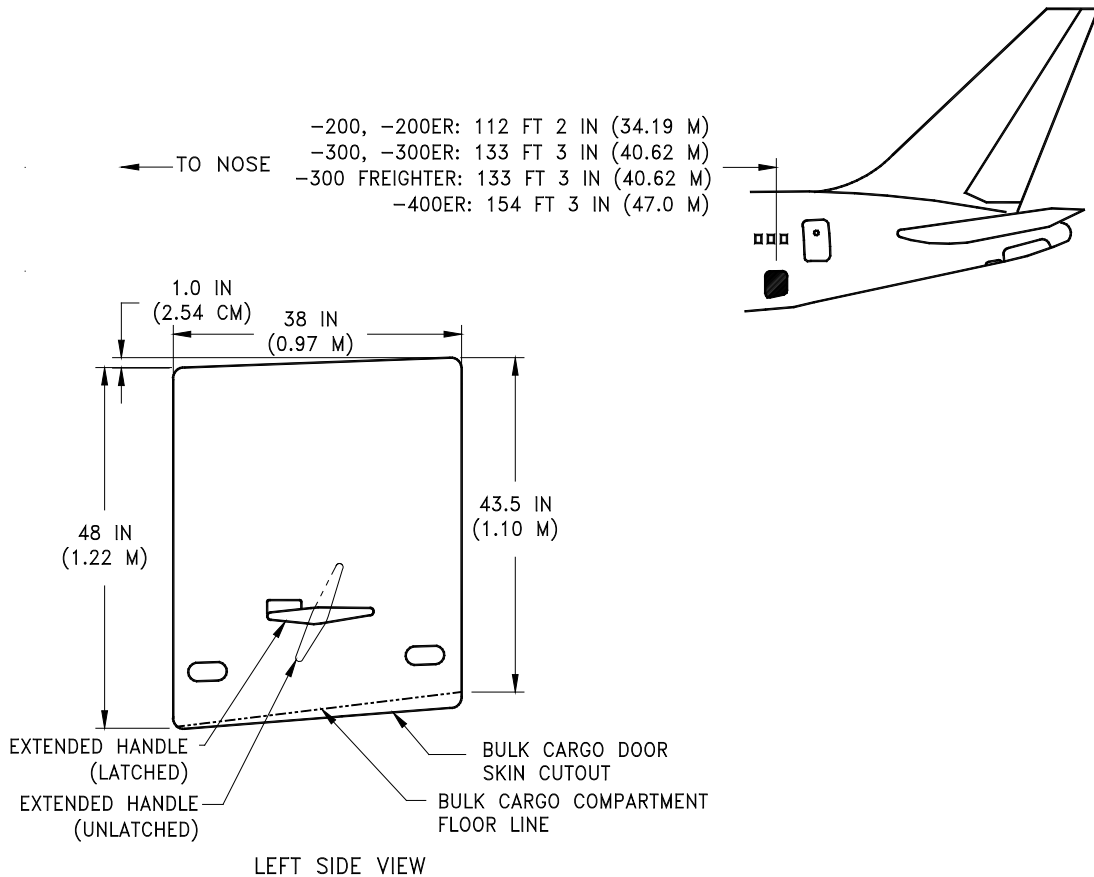

D6-58328

2.7.7 Door Clearances: Model 767-300 Freighter, Main Deck Cargo Door

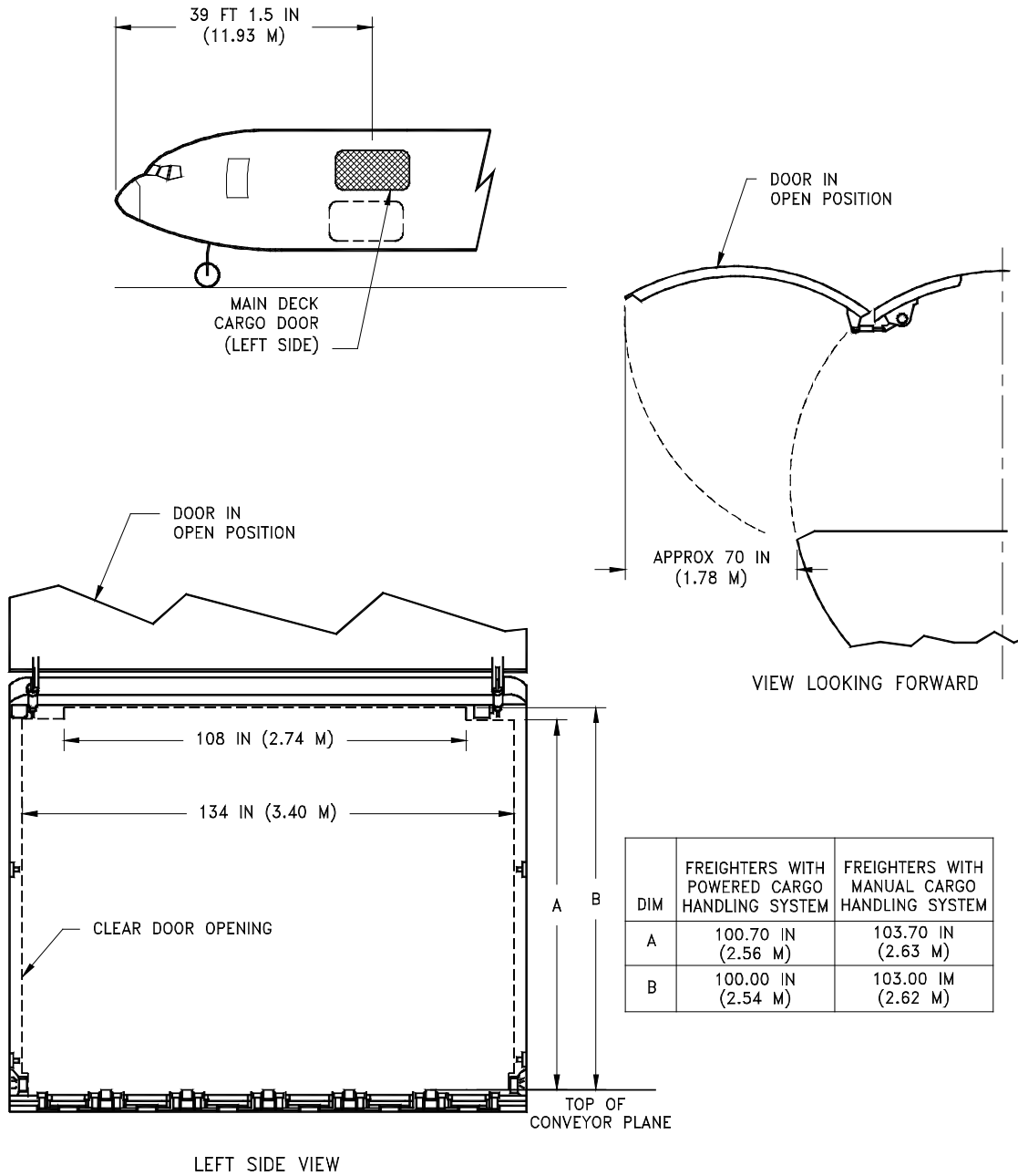

D6-58328

REV I

July 2021

2-36

3.0 AIRPLANE PERFORMANCE

3.1 GENERAL INFORMATION

The graph in Section 3.2 provides information on operational empty weight (OEW) and payload, trip range, brake release gross weight, and fuel limits for a typical 767-200, -200ER, -300, -300ER, -300 Freighter, and -400ER airplanes. To use this graph, if the trip range and zero fuel weight (OEW + payload) are known, the approximate brake release weight can be found, limited by fuel quantity.

The graphs in Section 3.3 provide information on FAA/EASA takeoff runway length requirements with typical engines at different pressure altitudes. Maximum takeoff weights shown on the graphs are the heaviest for the particular airplane models with the corresponding engines. Standard day temperatures for pressure altitudes shown on the FAA/EASA takeoff graphs are given below:

PRESSURE ALTITUDE		STANDARD DAY TEMP	
FEET	METERS	°F	°C
0	0	59.0	15.00
2,000	610	51.9	11.04
4,000	1,219	44.7	7.06
6,000	1,829	37.6	3.11
8,000	2,438	30.5	-0.85
10,000	3,048	23.3	-4.81

The graph in Section 3.4 provides information on landing runway length requirements for different airplane weights and airport altitudes. The maximum landing weights shown are the heaviest for the particular airplane model.

3.2 PAYLOAD/RANGE

3.2.1 Payload/Range: Model 767-200, Long-Range Cruise

NOTES:

- 0.80 MACH AT 35,000 AND 39,000 FT (10,668 AND 11,887 METERS)
- ATA DOMESTIC RESERVES
- STANDARD DAY
- TAKEOFF WEIGHTS ARE 2,000 LB (970 KG) LESS THAN TAXI WEIGHTS
- CONSULT USING AIRLINE FOR SPECIFIC OPERATING PROCEDURE PRIOR TO FACILITY DESIGN

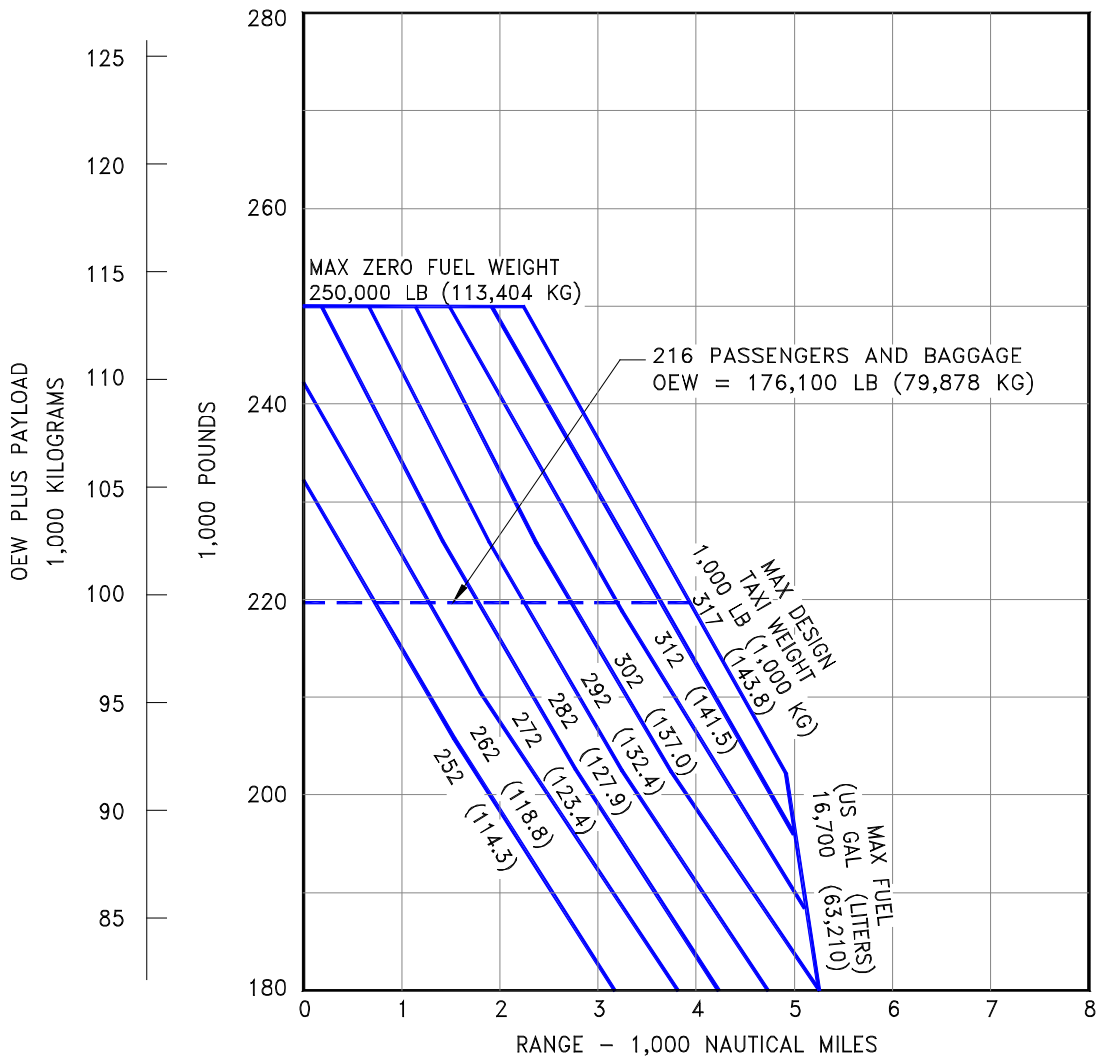

3.2.2 Payload/Range: Model 767-200ER, Long-Range Cruise

NOTES:

- 0.80 MACH AT 35,000 AND 39,000 FT (10,668 AND 11,887 METERS)
- ATA DOMESTIC RESERVES
- STANDARD DAY
- TAKEOFF WEIGHTS ARE 1,000 LB (454 KG) LESS THAN TAXI WEIGHTS
- CONSULT USING AIRLINE FOR SPECIFIC OPERATING PROCEDURE PRIOR TO FACILITY DESIGN

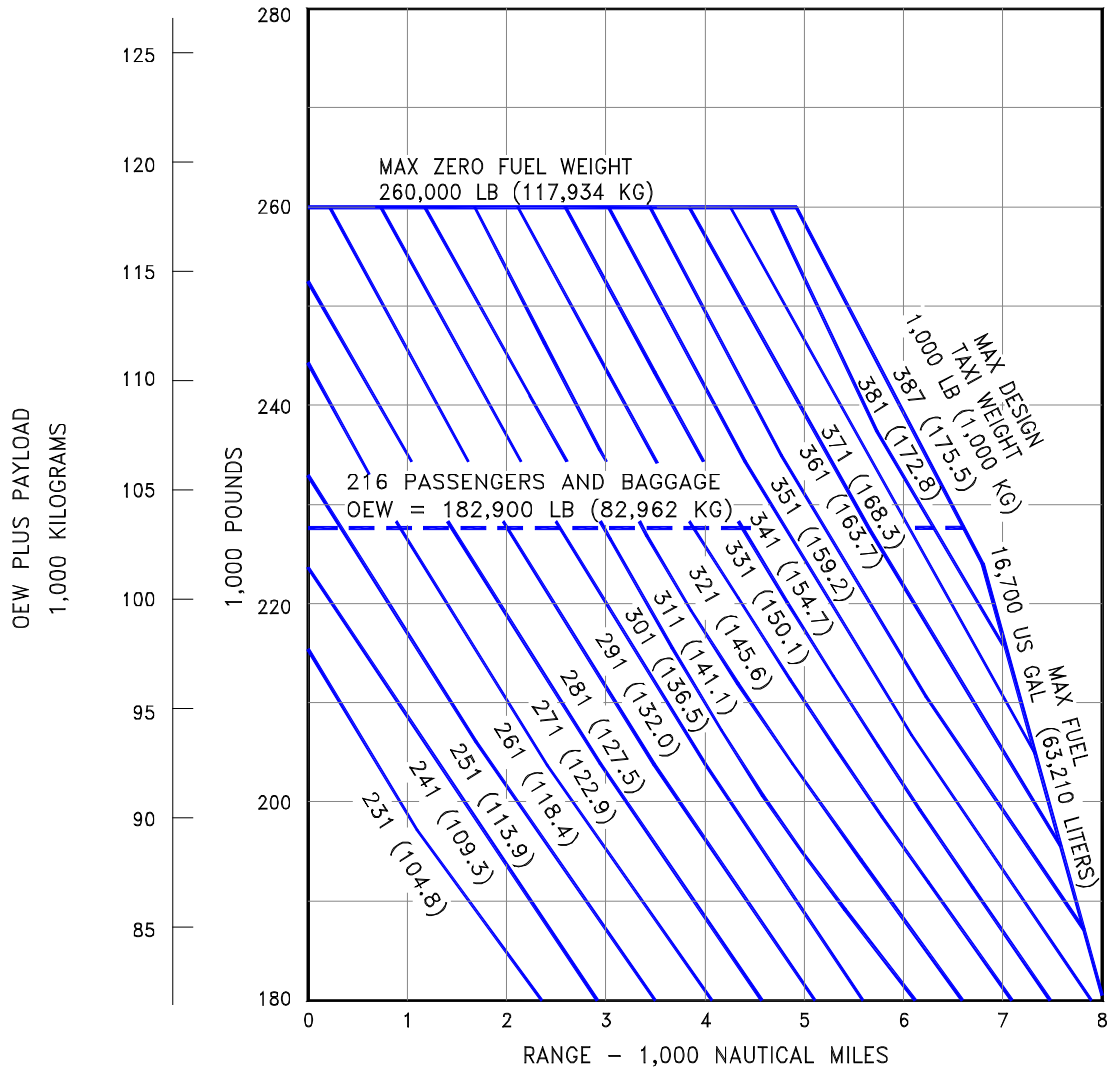

3.2.3 Payload/Range: Model 767-300, Long-Range Cruise

NOTES:

- 0.80 MACH AT 35,000 AND 39,000 FT (10,668 AND 11,887 METERS)
- ATA DOMESTIC RESERVES
- STANDARD DAY
- TAKEOFF WEIGHTS ARE 2,000 LB (907 KG) LESS THAN TAXI WEIGHTS
- CONSULT USING AIRLINE FOR SPECIFIC OPERATING PROCEDURE PRIOR TO FACILITY DESIGN

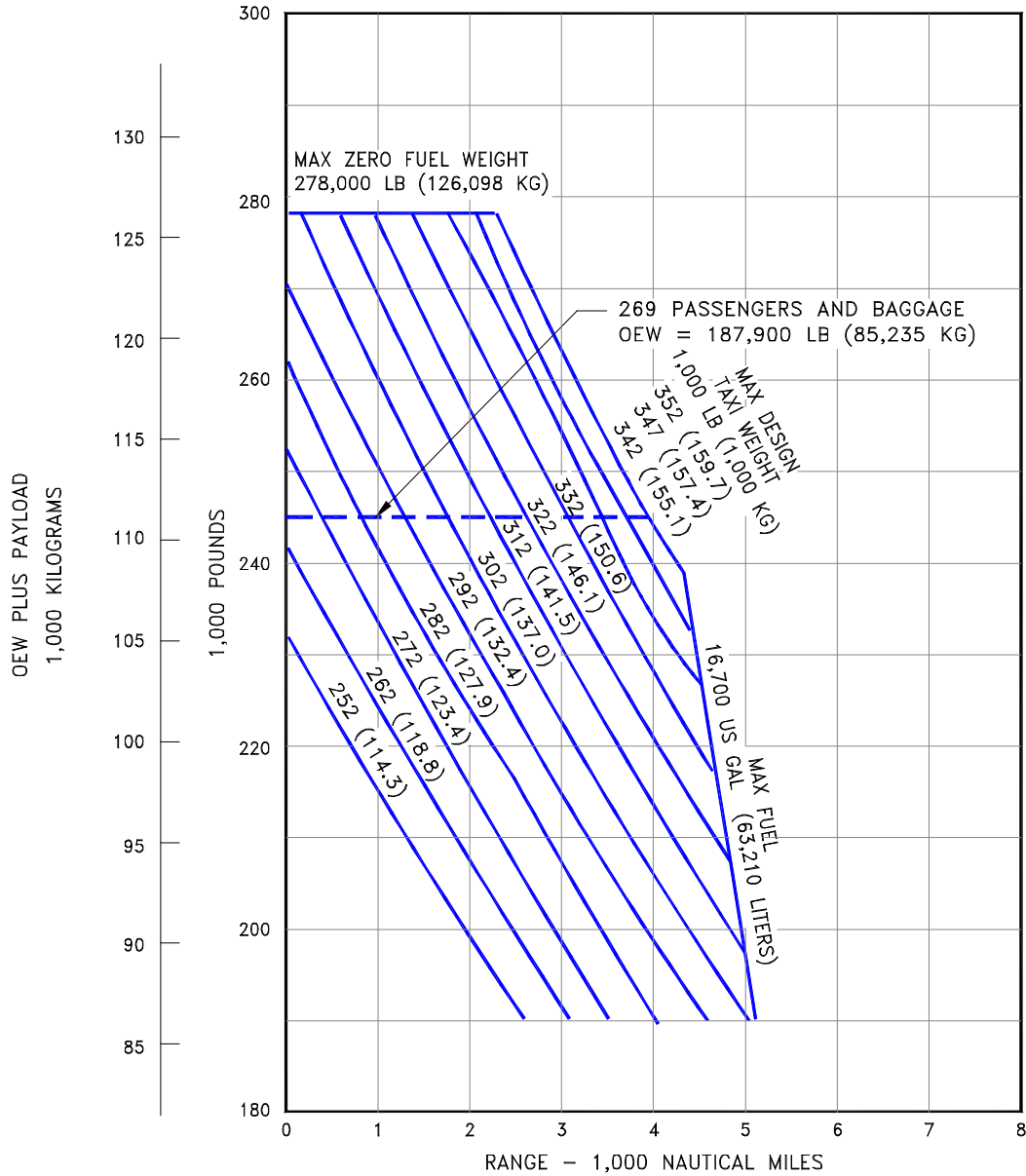

3.2.4 Payload/Range: Model 767-300ER, -300 Freighter, Long-Range Cruise

NOTES:

- 0.80 MACH AT 35,000 AND 39,000 FT (10,668 AND 11,887 METERS)
- ATA DOMESTIC RESERVES
- STANDARD DAY
- TAKEOFF WEIGHTS ARE 1,000 LB (454 KG) LESS THAN TAXI WEIGHTS
- CONSULT USING AIRLINE FOR SPECIFIC OPERATING PROCEDURE PRIOR TO FACILITY DESIGN

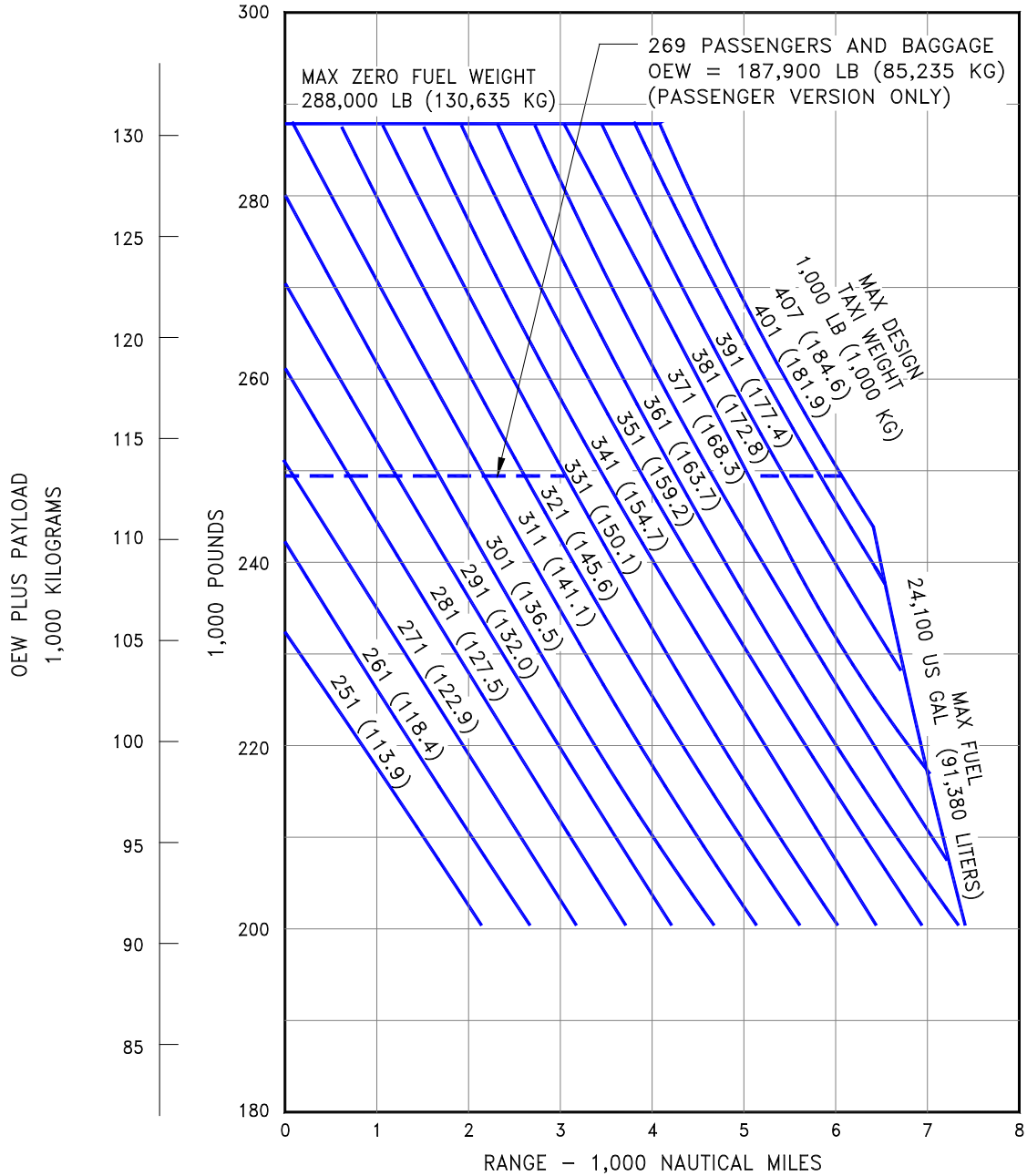

D6-58328

3.2.5 Payload/Range: Model 767-300ER, Long-Range Cruise, (CF6-80C2B7F1 Engines)

NOTES:

- 0.80 MACH AT 35,000 AND 39,000 FT (10,668 AND 11,887 METERS)
- ATA DOMESTIC RESERVES
- STANDARD DAY
- TAKEOFF WEIGHTS ARE 1,000 LB (454 KG) LESS THAN TAXI WEIGHTS
- CONSULT USING AIRLINE FOR SPECIFIC OPERATING PROCEDURE PRIOR TO FACILITY DESIGN

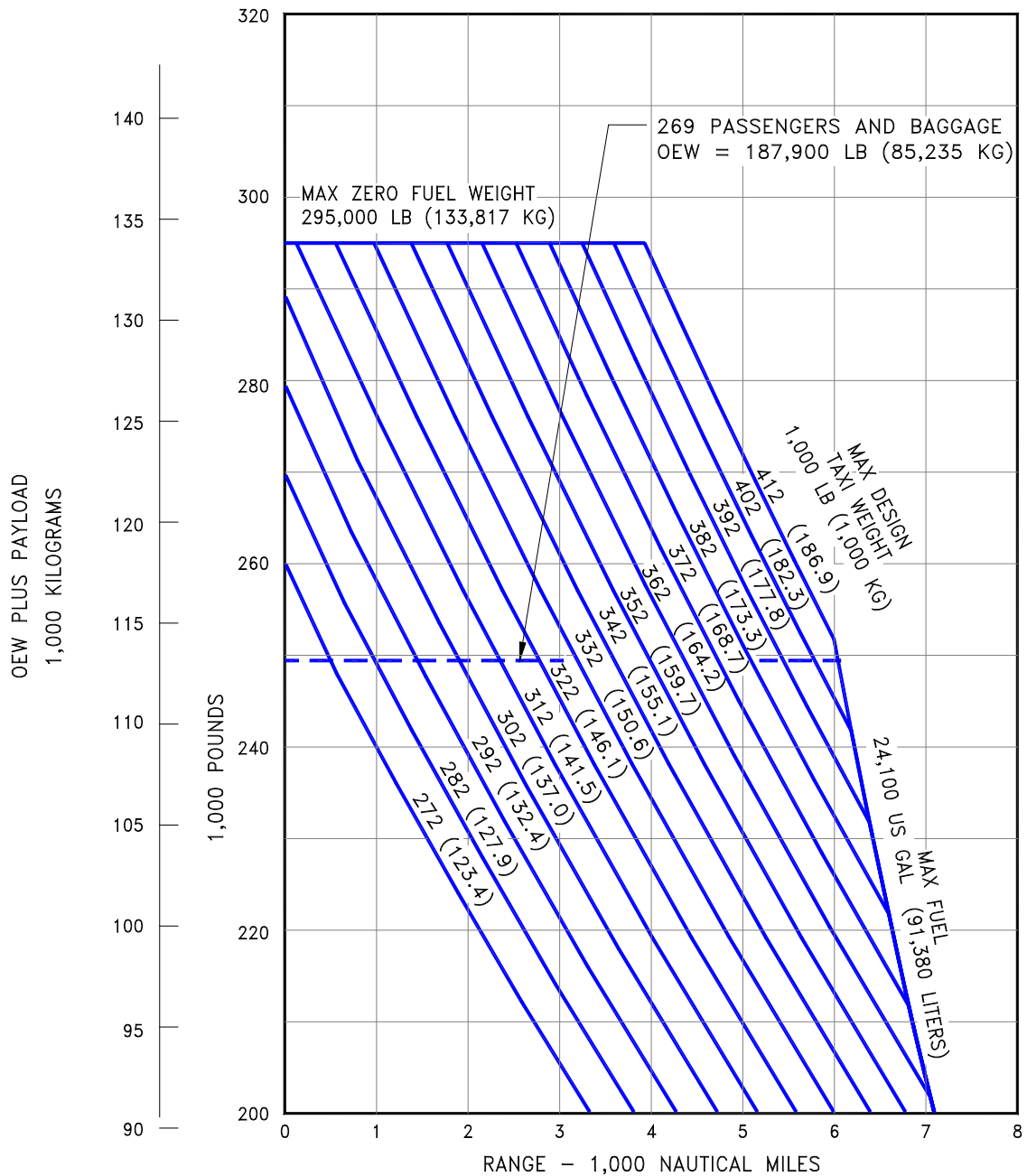

D6-58328

3.2.6 Payload/Range: Model 767-300ER, Long-Range Cruise, (PW4062 Engines)

NOTES:

- 0.80 MACH AT 35,000 AND 39,000 FT (10,668 AND 11,887 METERS)
- ATA DOMESTIC RESERVES
- STANDARD DAY
- TAKEOFF WEIGHTS ARE 1,000 LB (454 KG) LESS THAN TAXI WEIGHTS
- CONSULT USING AIRLINE FOR SPECIFIC OPERATING PROCEDURE PRIOR TO FACILITY DESIGN

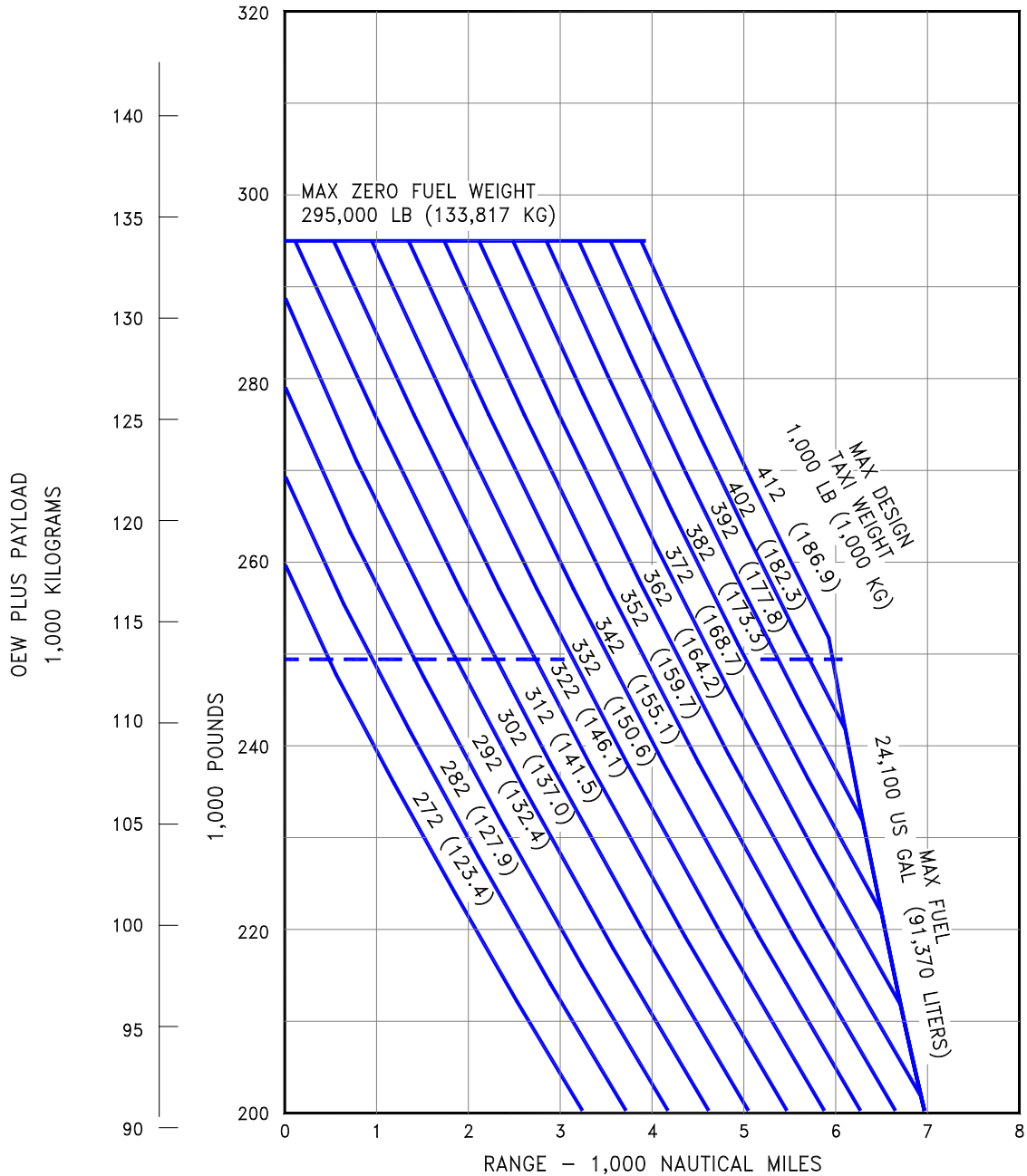

3.2.7 Payload/Range: Model 767-300 Freighter, Long-Range Cruise, (CF6-80C2B7F1 Engines)

NOTES:

- 0.80 MACH AT 35,000 AND 39,000 FT (10,668 AND 11,887 METERS)
- ATA DOMESTIC RESERVES
- STANDARD DAY
- TAKEOFF WEIGHTS ARE 1,000 LB (454 KG) LESS THAN TAXI WEIGHTS
- CONSULT USING AIRLINE FOR SPECIFIC OPERATING PROCEDURE PRIOR TO FACILITY DESIGN

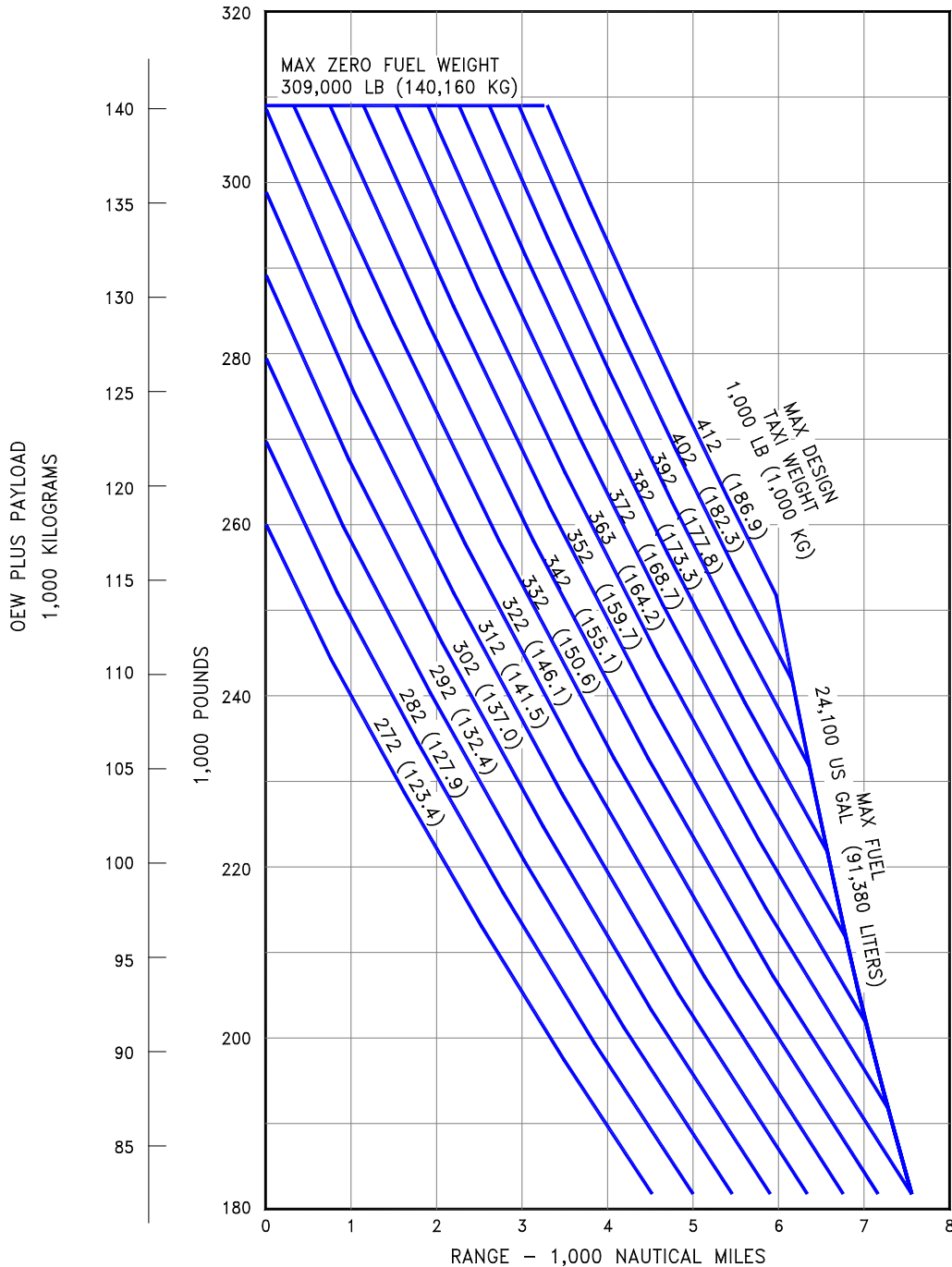

D6-58328

3.2.8 Payload/Range: Model 767-300 Freighter, Long-Range Cruise, (PW4062 Engines)

NOTES:

- 0.80 MACH AT 35,000 AND 39,000 FT (10,668 AND 11,887 METERS)
- ATA DOMESTIC RESERVES
- STANDARD DAY
- TAKEOFF WEIGHTS ARE 1,000 LB (454 KG) LESS THAN TAXI WEIGHTS
- CONSULT USING AIRLINE FOR SPECIFIC OPERATING PROCEDURE PRIOR TO FACILITY DESIGN

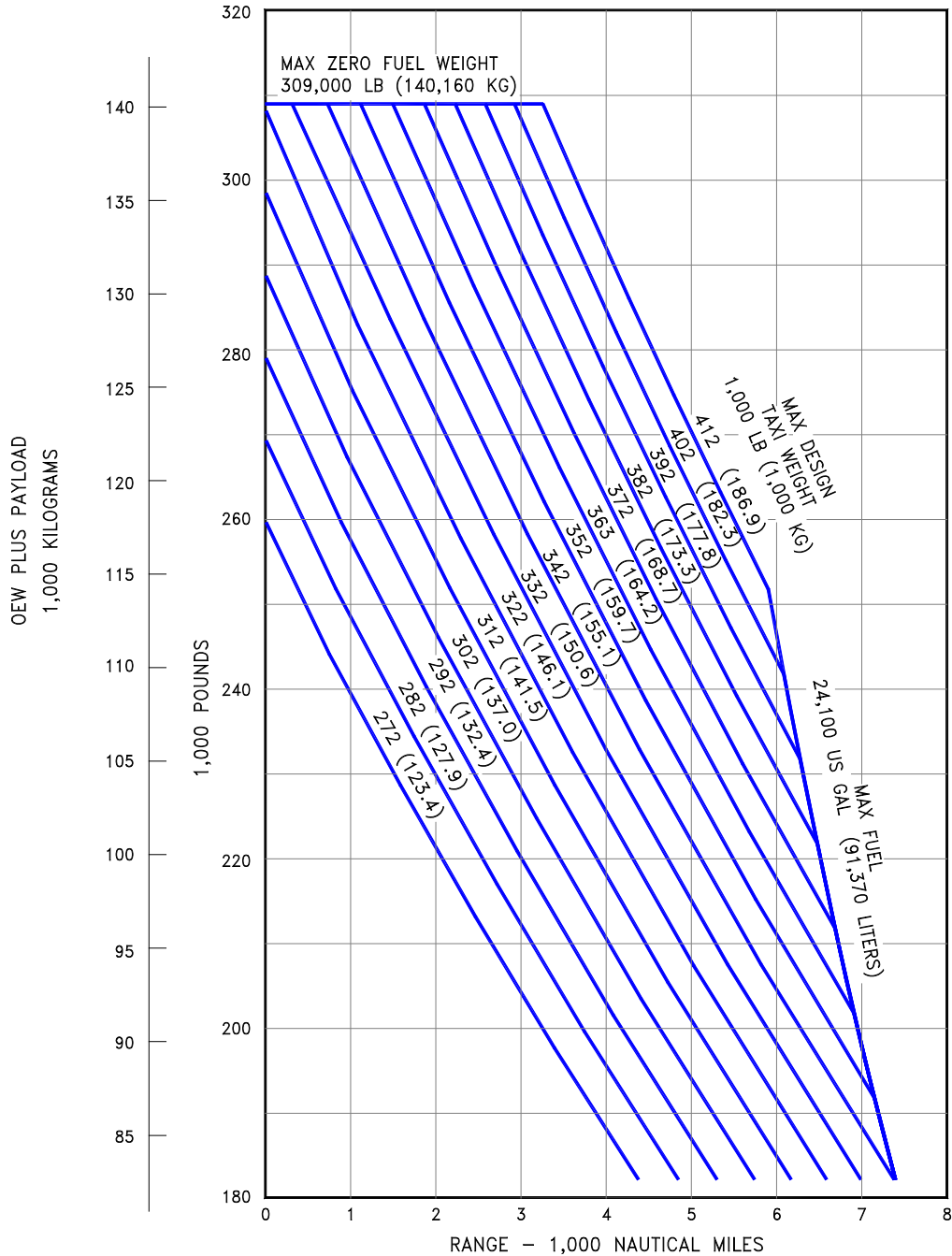

3.2.9 Payload/Range: Model 767-400ER, Long-Range Cruise, (CF6-80C2B8 Engines)

NOTES:

- CF6-80C2B8F ENGINES
- 31-35-39,000 FT STEP CRUISE
- CRUISE MACH = 0.80
- TYPICAL MISSION RULES
- STANDARD DAY
- 200 NMI ALTERNATE
- NOMINAL PERFORMANCE
- TAKEOFF WEIGHTS ARE 1000 LB LESS THAN CORRESPONDING TAXI WEIGHTS
- CONSULT USING AIRLINES FOR SPECIFIC OPERATING PROCEDURES PRIOR TO FACILITY DESIGN

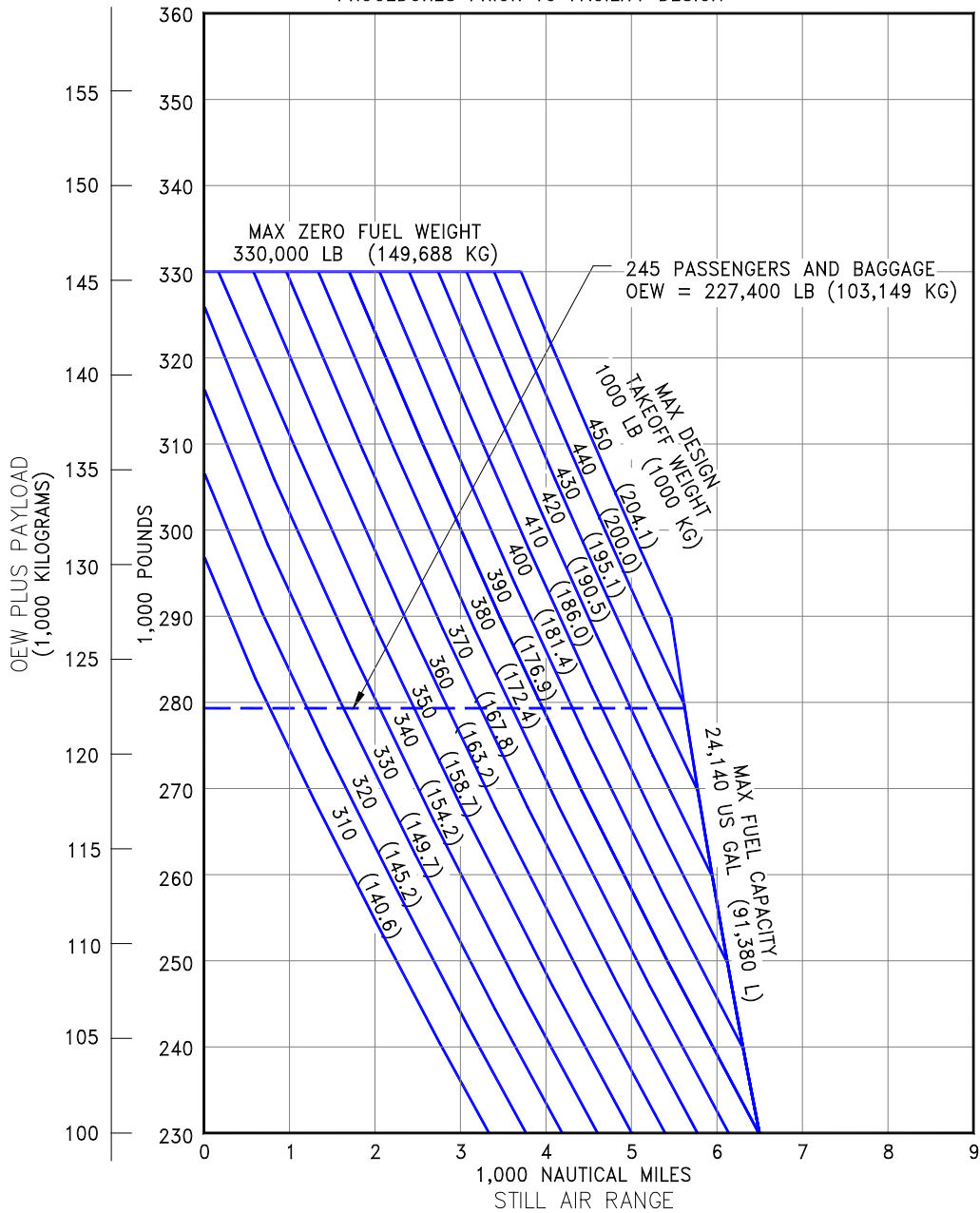

D6-58328

3.2.10 Payload/Range: Model 767-400ER, Long-Range Cruise, (PW4062 Engines)

NOTES:

- PW4062 ENGINES
- 31–35–39,000 FT STEP CRUISE
- CRUISE MACH = 0.80
- TYPICAL MISSION RULES
- STANDARD DAY
- 200 NMI ALTERNATE
- NOMINAL PERFORMANCE
- TAKEOFF WEIGHTS ARE 1000 LB LESS THAN CORRESPONDING TAXI WEIGHTS
- CONSULT USING AIRLINES FOR SPECIFIC OPERATING PROCEDURES PRIOR TO FACILITY DESIGN

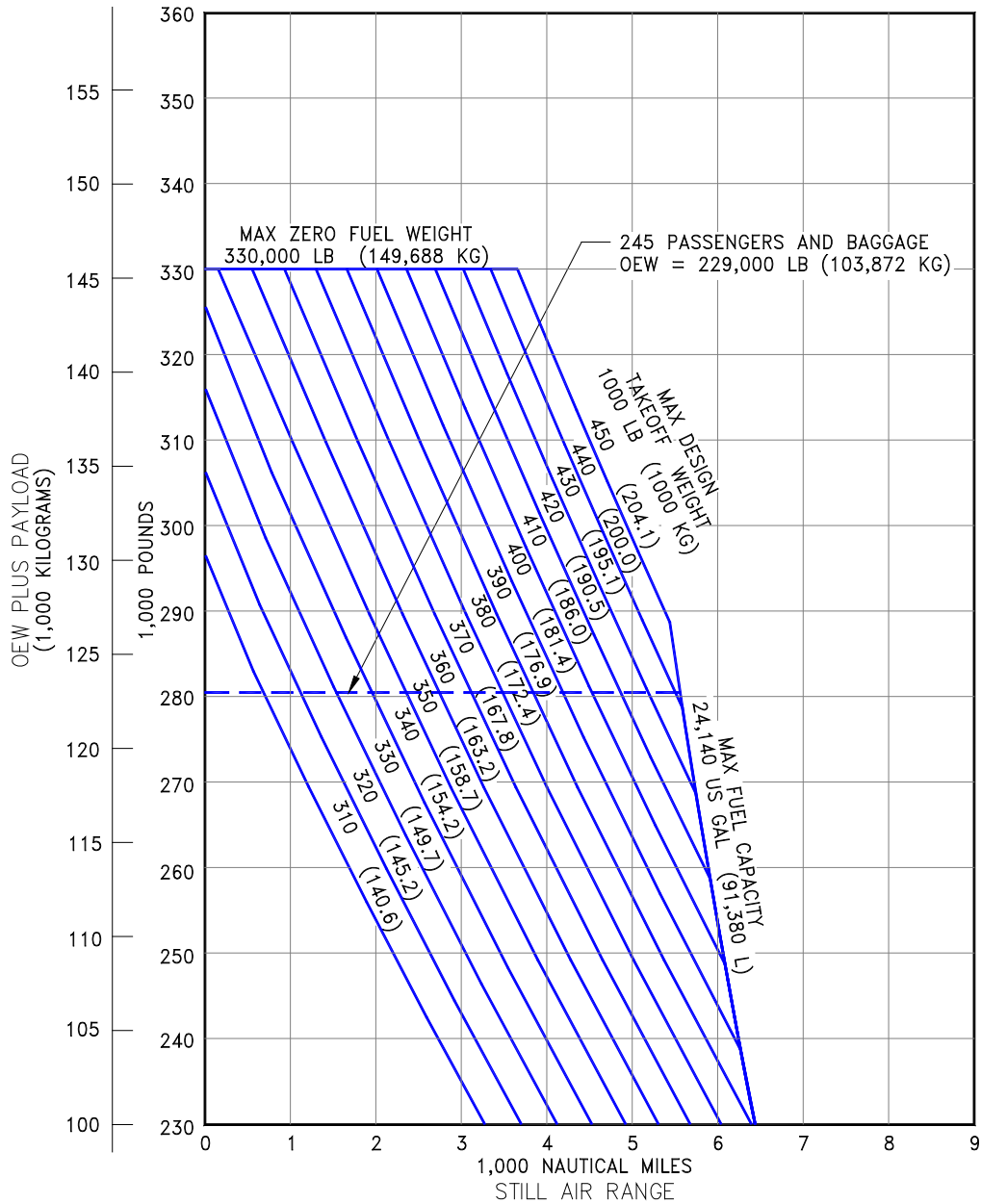

3.3 FAA/EASA TAKEOFF RUNWAY LENGTH REQUIREMENTS

3.3.1 FAA/EASA Takeoff Runway Length Requirements - Standard Day: Model 767-200, -200ER (JT9D-7R4D/7R4E, CF6-80A/80A2 Engines)

NOTES:

- JT9D-7R4D/7R4E, CF6-80A/80A2 ENGINES
- ZERO RUNWAY GRADIENT
- ZERO WIND
- AIR CONDITIONING OFF
- CONSULT USING AIRLINE FOR SPECIFIC OPERATING PROCEDURE PRIOR TO FACILITY DESIGN

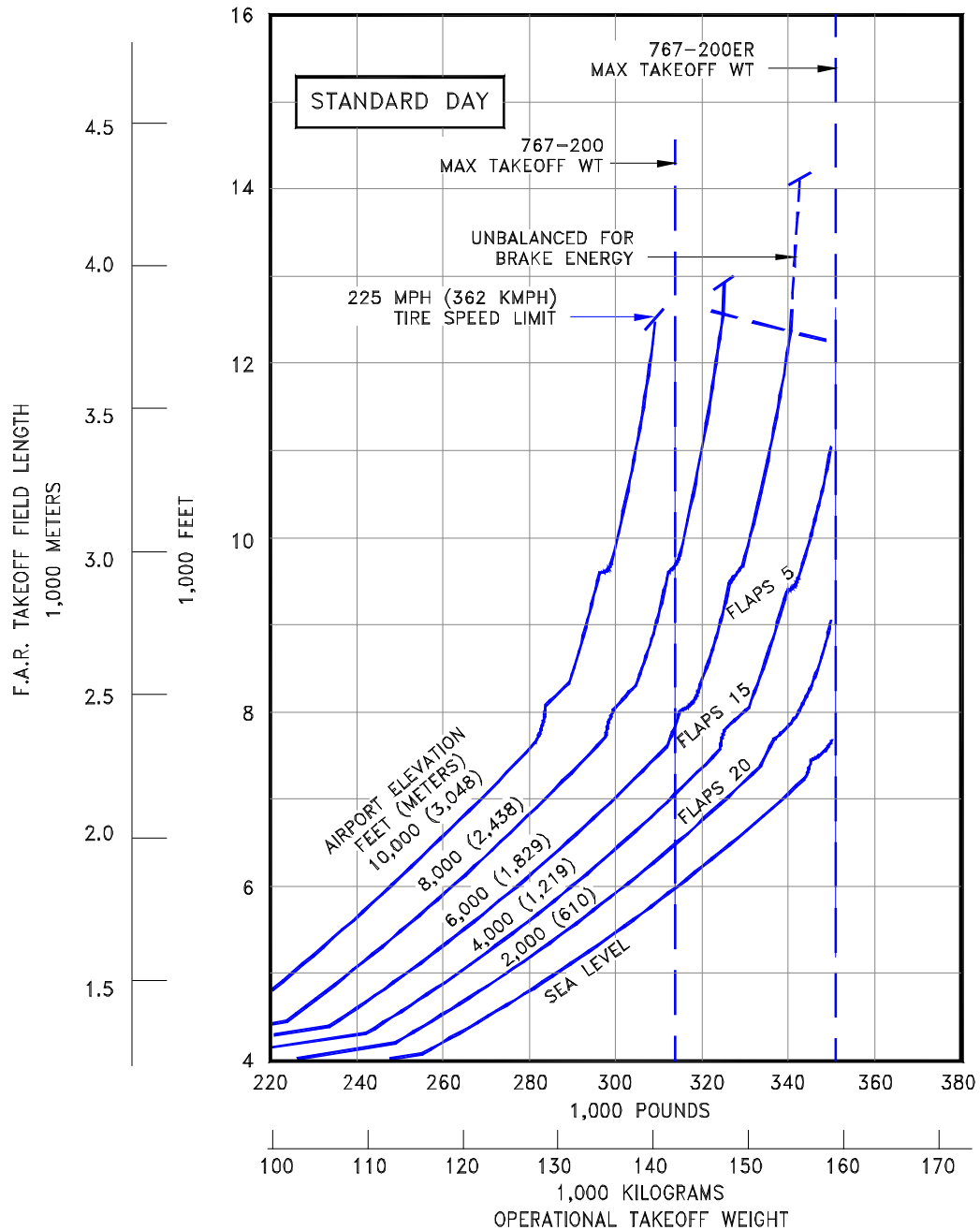

D6-58328

REV I

July 2021

3-12

3.3.2 FAA/EASA Takeoff Runway Length Requirements - Standard Day + 31°F (STD + 17°C): Model 767-200, -200ER (JT9D-7R4D/7R4E, CF6-80A/80A2 Engines)

NOTES:

- JT9D-7R4D/7R4E, CF6-80A/80A2 ENGINES
- ZERO RUNWAY GRADIENT
- ZERO WIND
- AIR CONDITIONING OFF
- CONSULT USING AIRLINE FOR SPECIFIC OPERATING PROCEDURE PRIOR TO FACILITY DESIGN

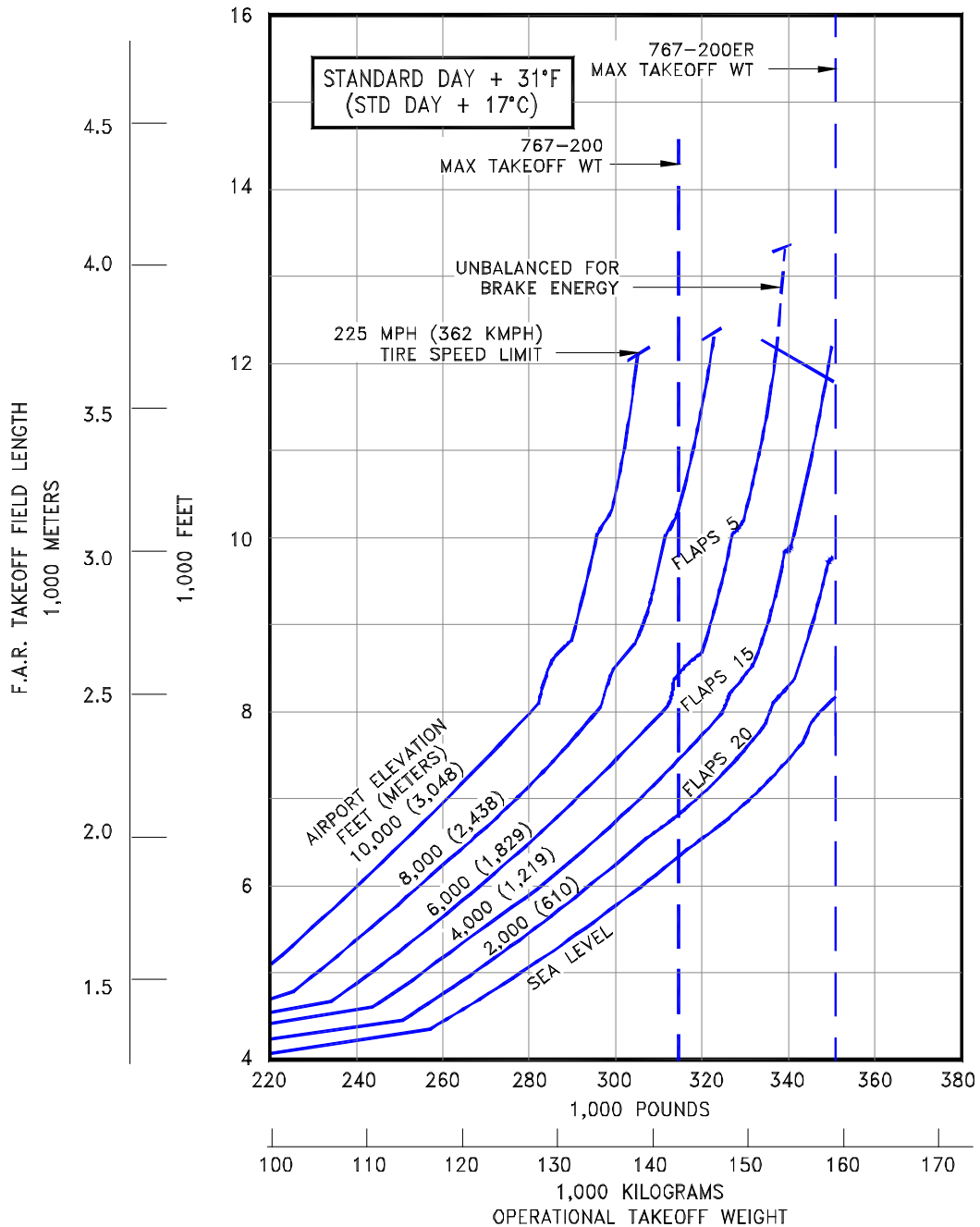

D6-58328

3.3.3 FAA/EASA Takeoff Runway Length Requirements - Standard Day: Model 767-200, -200ER (CF6-80C2B2, PW4052 Engines)

NOTES:

- CF6-80C2B2, PW4052 ENGINES
- ZERO RUNWAY GRADIENT
- ZERO WIND
- AIR CONDITIONING OFF
- CONSULT USING AIRLINE FOR SPECIFIC OPERATING PROCEDURE PRIOR TO FACILITY DESIGN

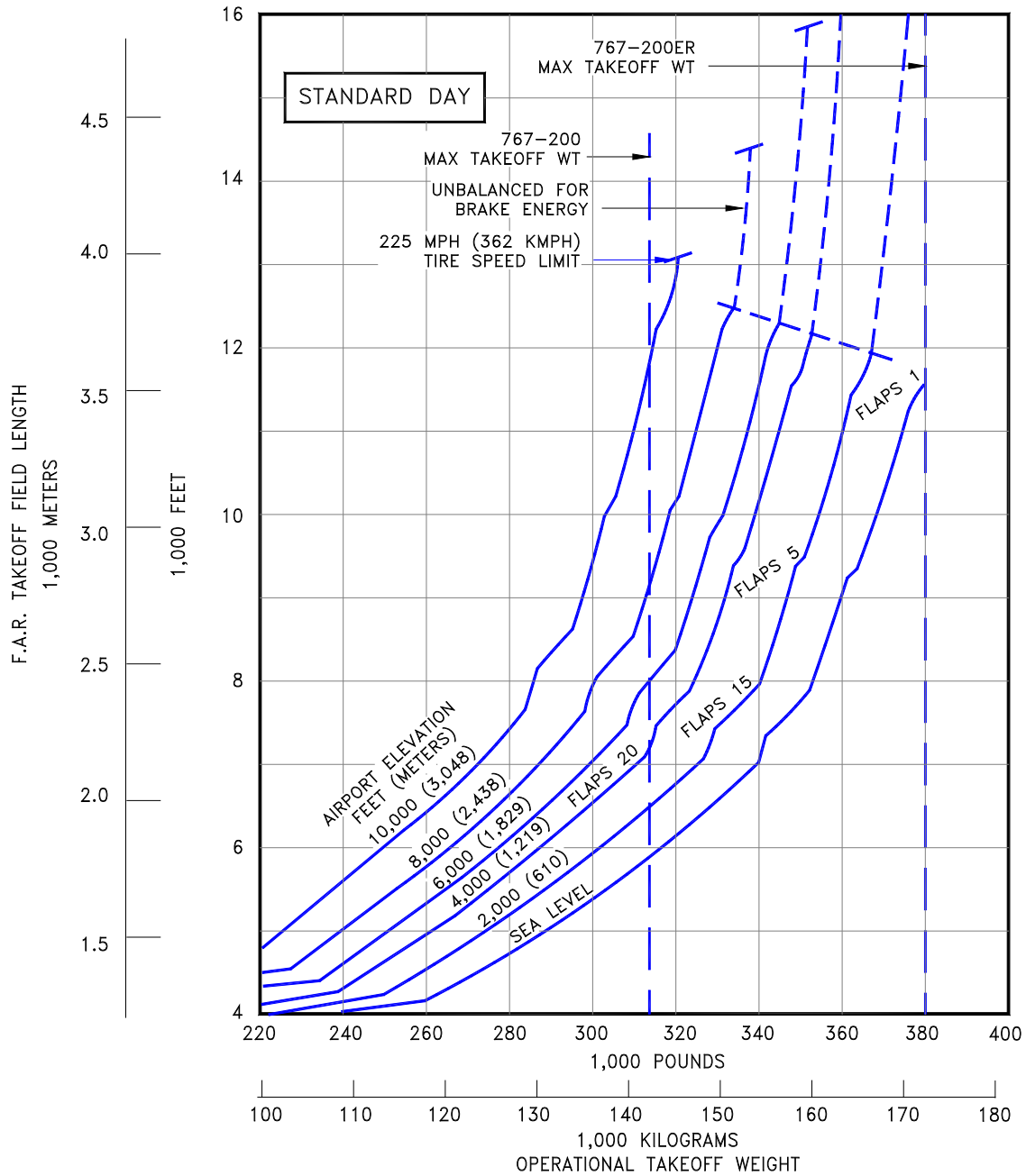

3.3.4 FAA/EASA Takeoff Runway Length Requirements - Standard Day + 31°F (STD + 17°C): Model 767-200, -200ER (CF6-80C2B2, PW4052 Engines)

NOTES:

- CF6-80C2B2, PW4052 ENGINES
- ZERO RUNWAY GRADIENT
- ZERO WIND
- AIR CONDITIONING OFF
- CONSULT USING AIRLINE FOR SPECIFIC OPERATING PROCEDURE PRIOR TO FACILITY DESIGN

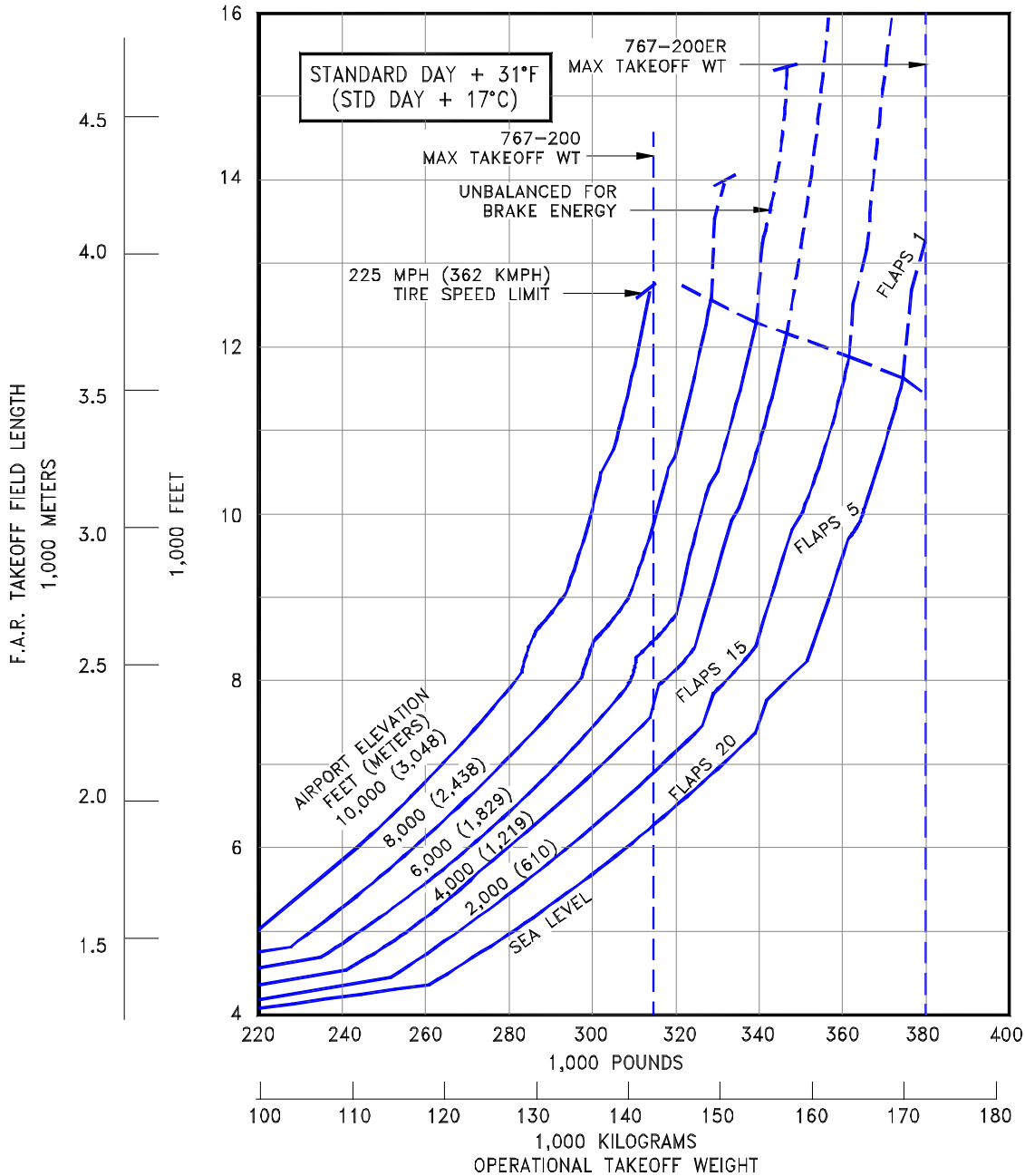

D6-58328

REV I

July 2021

3-15

3.3.5 FAA/EASA Takeoff Runway Length Requirements - Standard Day: Model 767-200ER (CF6-80C2B4, PW4056, RB211-524G Engines)

NOTES:

- CF6-80C2B4, PW4056, RB211-524G ENGINES
- ZERO RUNWAY GRADIENT
- ZERO WIND
- AIR CONDITIONING OFF
- CONSULT USING AIRLINE FOR SPECIFIC OPERATING PROCEDURE PRIOR TO FACILITY DESIGN

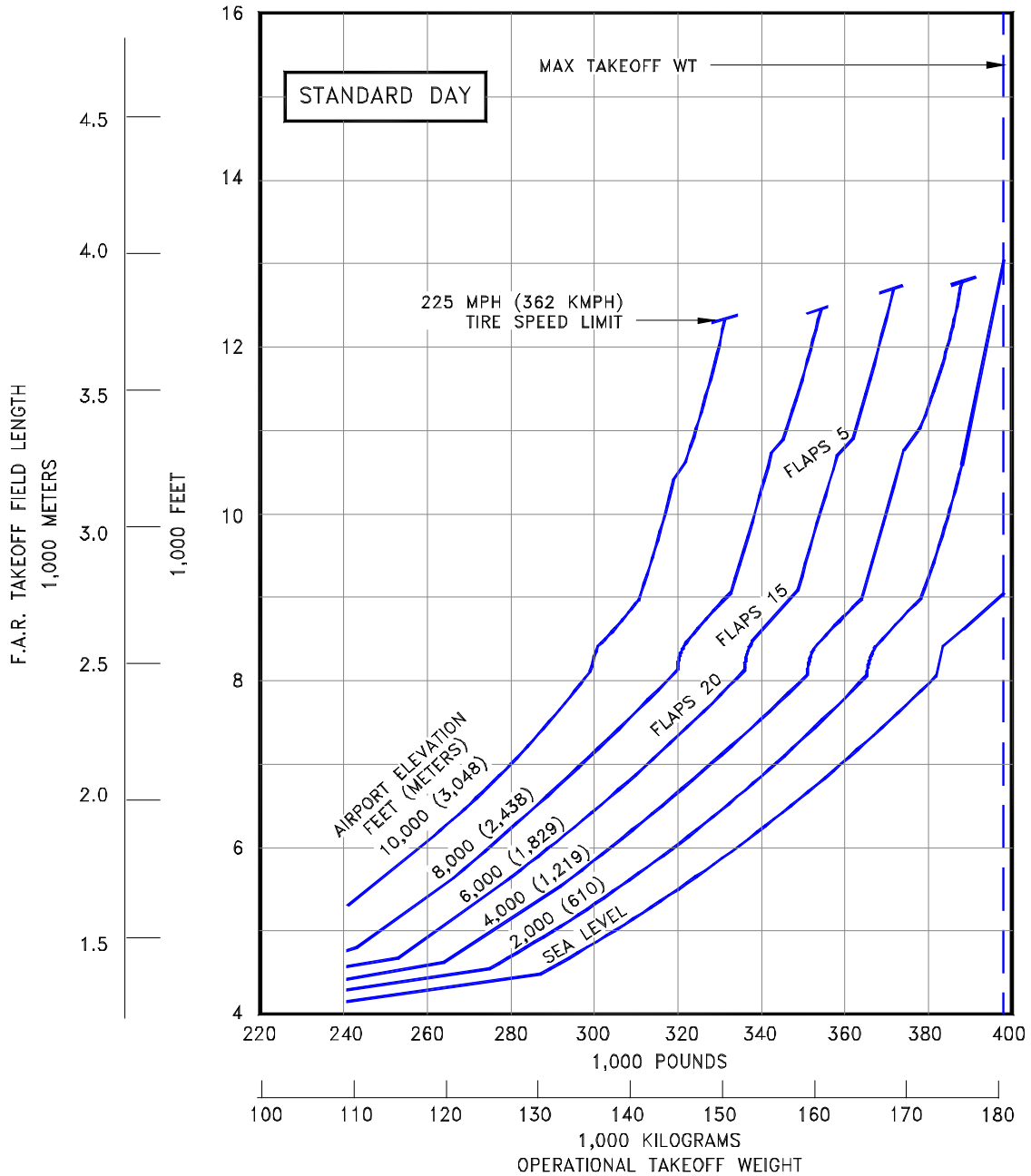

3.3.6 FAA/EASA Takeoff Runway Length Requirements - Standard Day + 31°F (STD + 17°C): Model 767-200ER (CF6-80C2B4, PW4056, RB211-524G Engines)

NOTES:

- CF6-80C2B4, PW4056, RB211-524G ENGINES
- ZERO RUNWAY GRADIENT
- ZERO WIND
- AIR CONDITIONING OFF
- CONSULT USING AIRLINE FOR SPECIFIC OPERATING PROCEDURE PRIOR TO FACILITY DESIGN

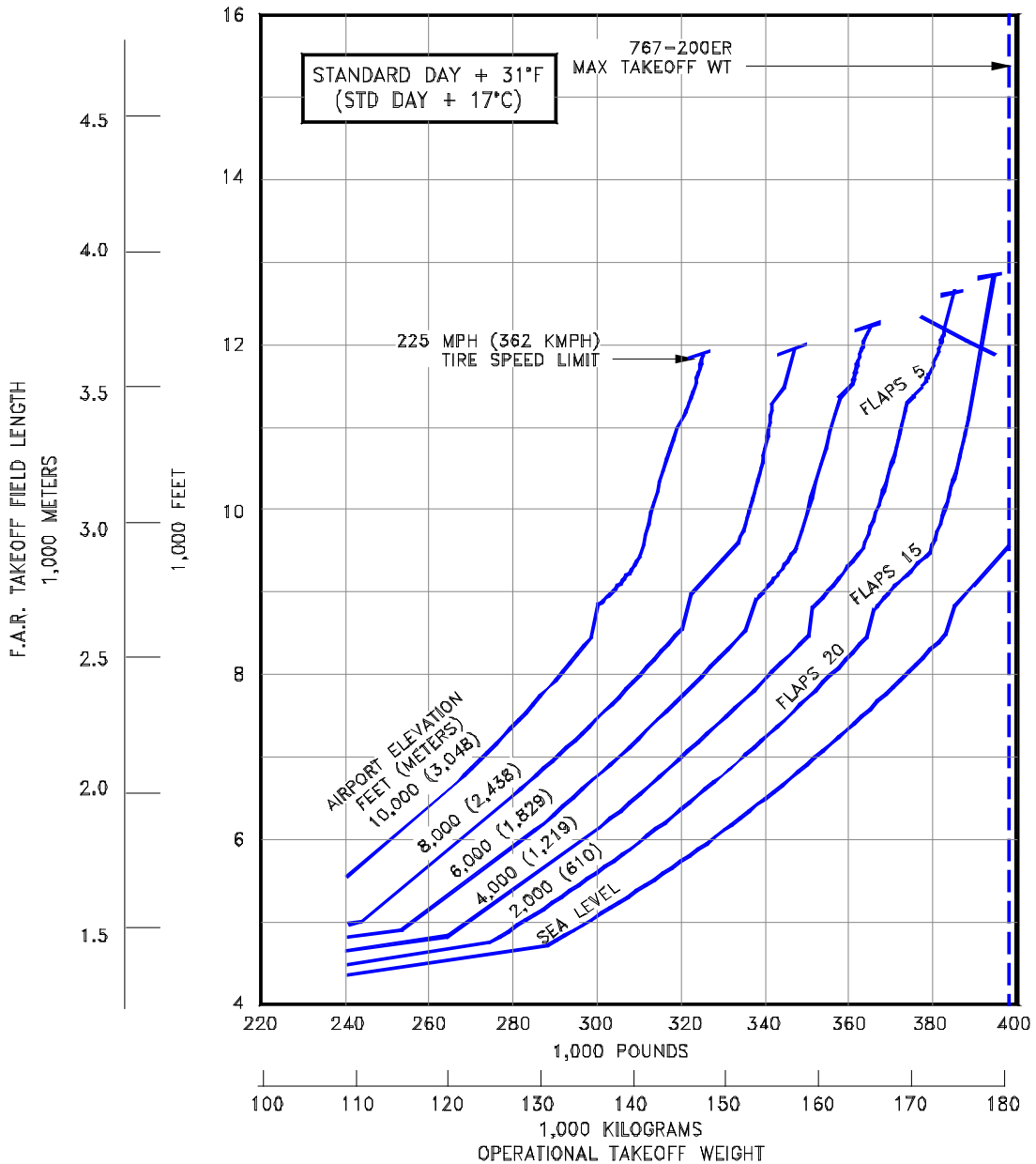

3.3.7 FAA/EASA Takeoff Runway Length Requirements - Standard Day: Model 767-300 (CF6-80A/80A2 Engines)

- NOTES:
- CF6-80A/80A2 ENGINES
 - ZERO RUNWAY GRADIENT
 - ZERO WIND
 - AIR CONDITIONING OFF
 - CONSULT USING AIRLINE FOR SPECIFIC OPERATING PROCEDURE PRIOR TO FACILITY DESIGN

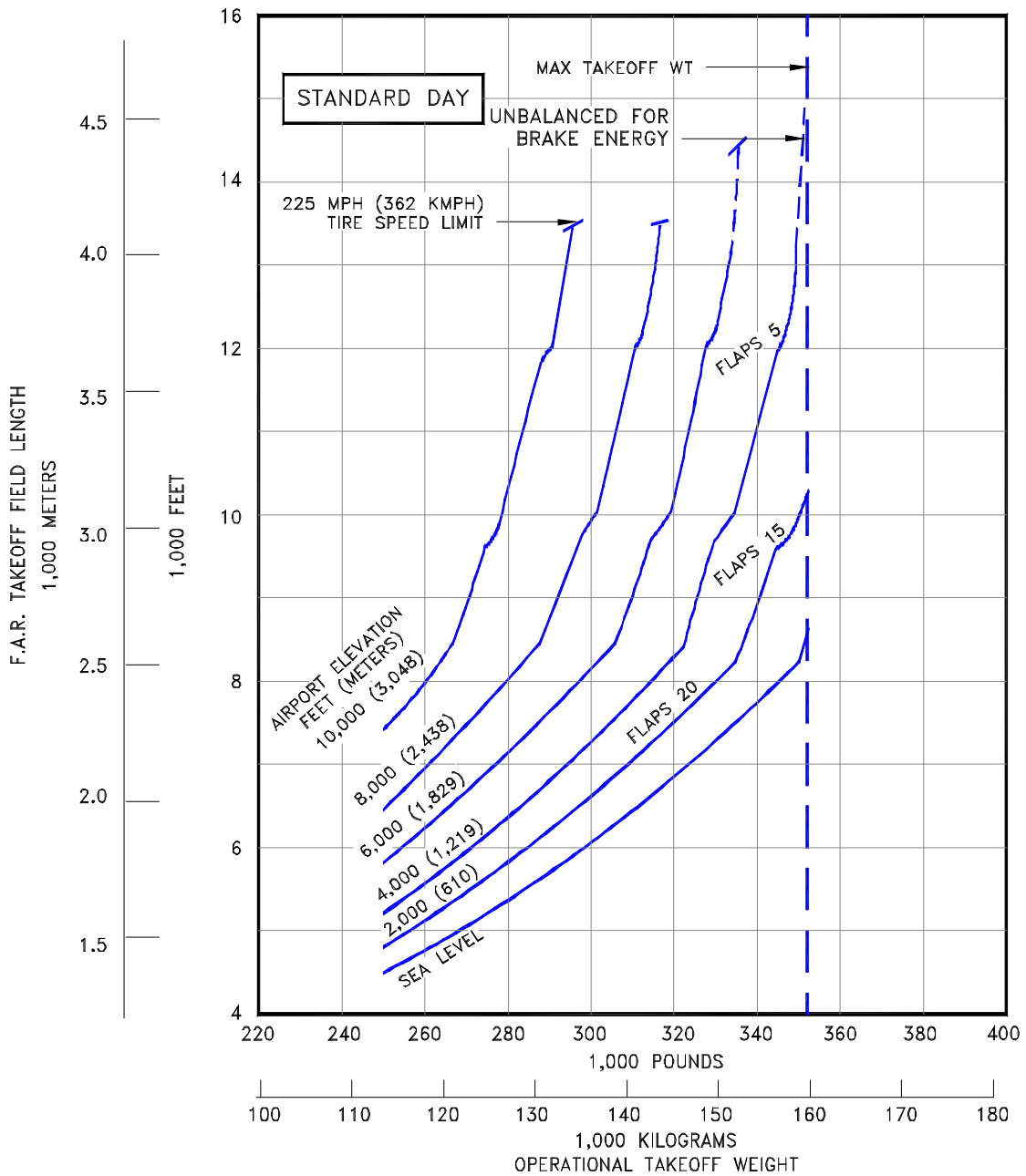

D6-58328

3.3.8 FAA/EASA Takeoff Runway Length Requirements - Standard Day + 33°F (STD + 18°C): Model 767-300 (CF6-80A/80A2 Engines)

NOTES:

- CF6-80A/80A2 ENGINES
- ZERO RUNWAY GRADIENT
- ZERO WIND
- AIR CONDITIONING OFF
- CONSULT USING AIRLINE FOR SPECIFIC OPERATING PROCEDURE PRIOR TO FACILITY DESIGN

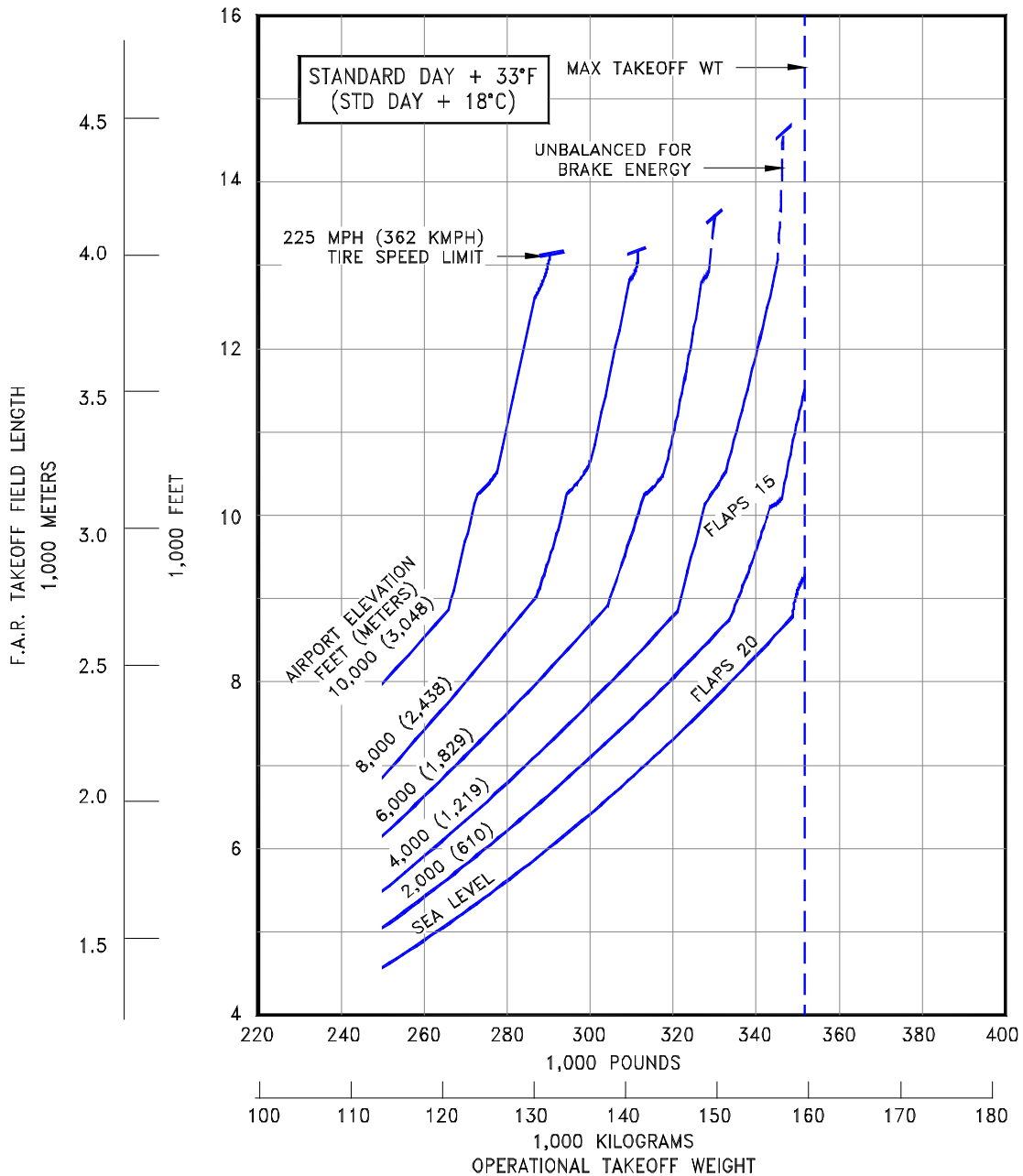

3.3.9 FAA/EASA Takeoff Runway Length Requirements - Standard Day: Model 767-300 (JT9D-7R4D/7R4E Engines)

NOTES:

- JT9D-74RD/74RE ENGINES
- ZERO RUNWAY GRADIENT
- ZERO WIND
- AIR CONDITIONING OFF
- CONSULT USING AIRLINE FOR SPECIFIC OPERATING PROCEDURE PRIOR TO FACILITY DESIGN

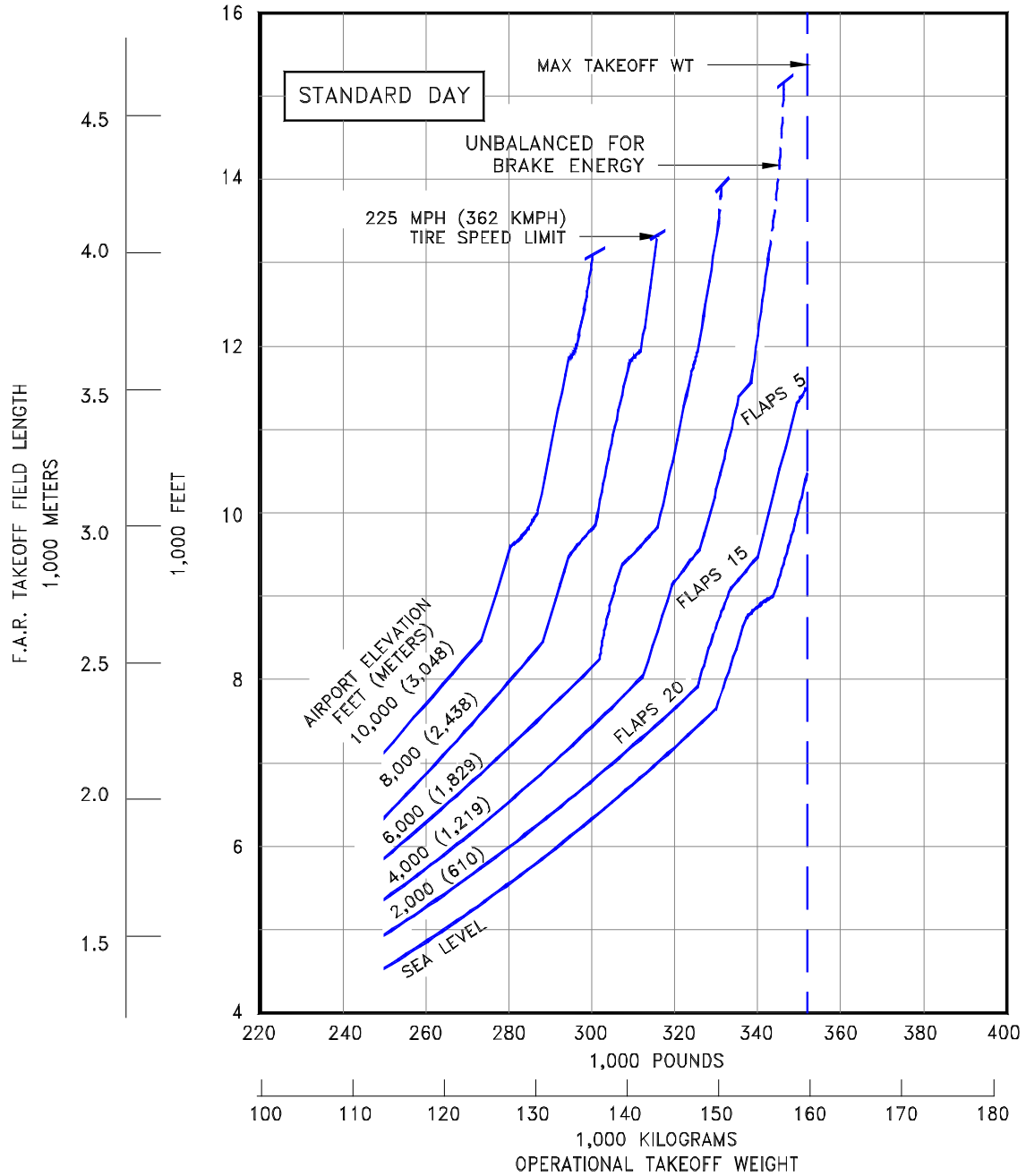

D6-58328

3.3.10 FAA/EASA Takeoff Runway Length Requirements - Standard Day + 27°F (STD + 15°C): Model 767-300 (JT9D-7R4D/7R4E Engines)

NOTES:

- JT9D-7R4D/7R4E ENGINES
- ZERO RUNWAY GRADIENT
- ZERO WIND
- AIR CONDITIONING OFF
- CONSULT USING AIRLINE FOR SPECIFIC OPERATING PROCEDURE PRIOR TO FACILITY DESIGN

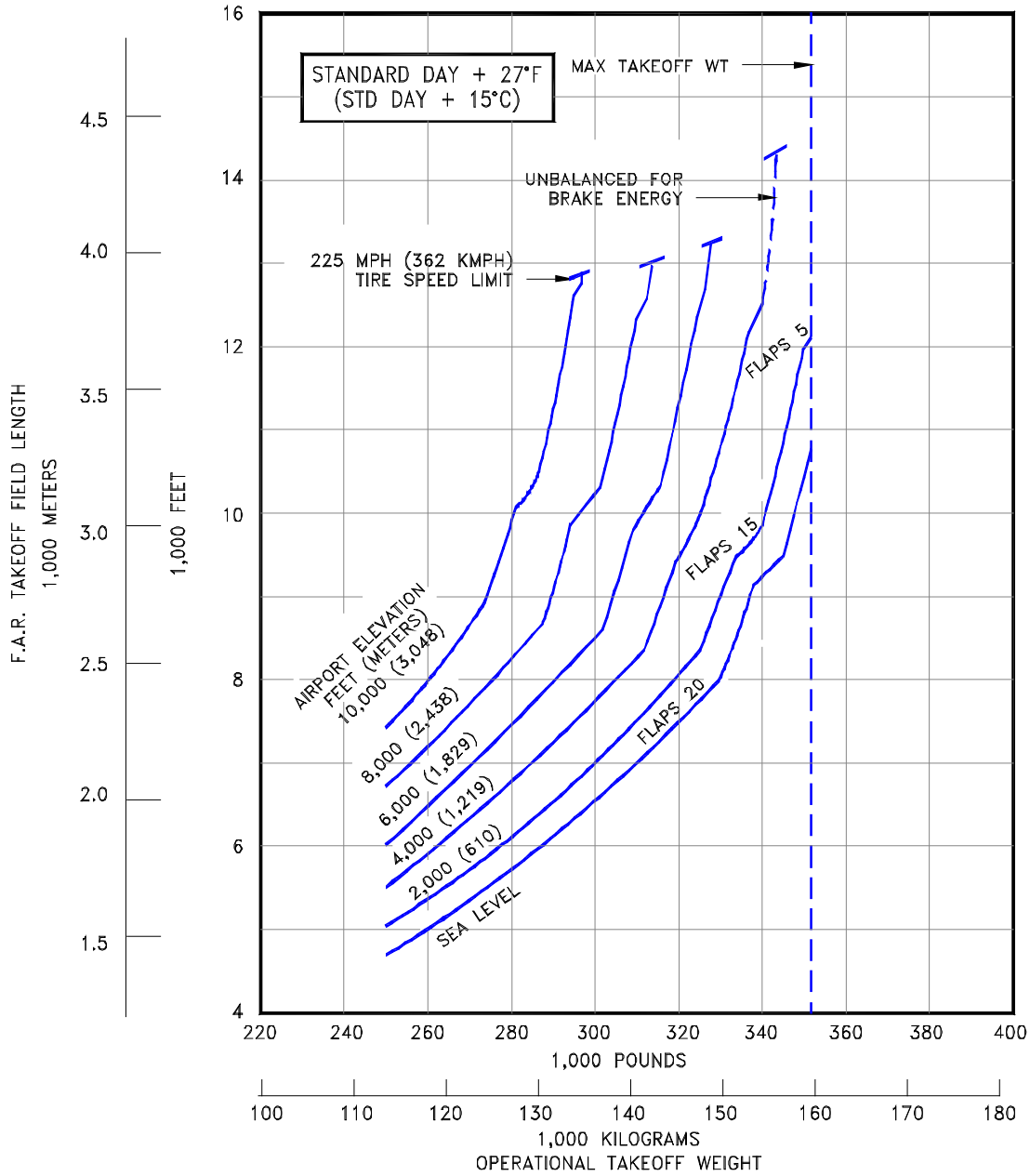

3.3.11 FAA/EASA Takeoff Runway Length Requirements - Standard Day: Model 767-300 (CF6-80C2B2, PW4052 Engines)

NOTES:

- CF6-80C2-B2, PW4052 ENGINES
- ZERO RUNWAY GRADIENT
- ZERO WIND
- AIR CONDITIONING OFF
- CONSULT USING AIRLINE FOR SPECIFIC OPERATING PROCEDURE PRIOR TO FACILITY DESIGN

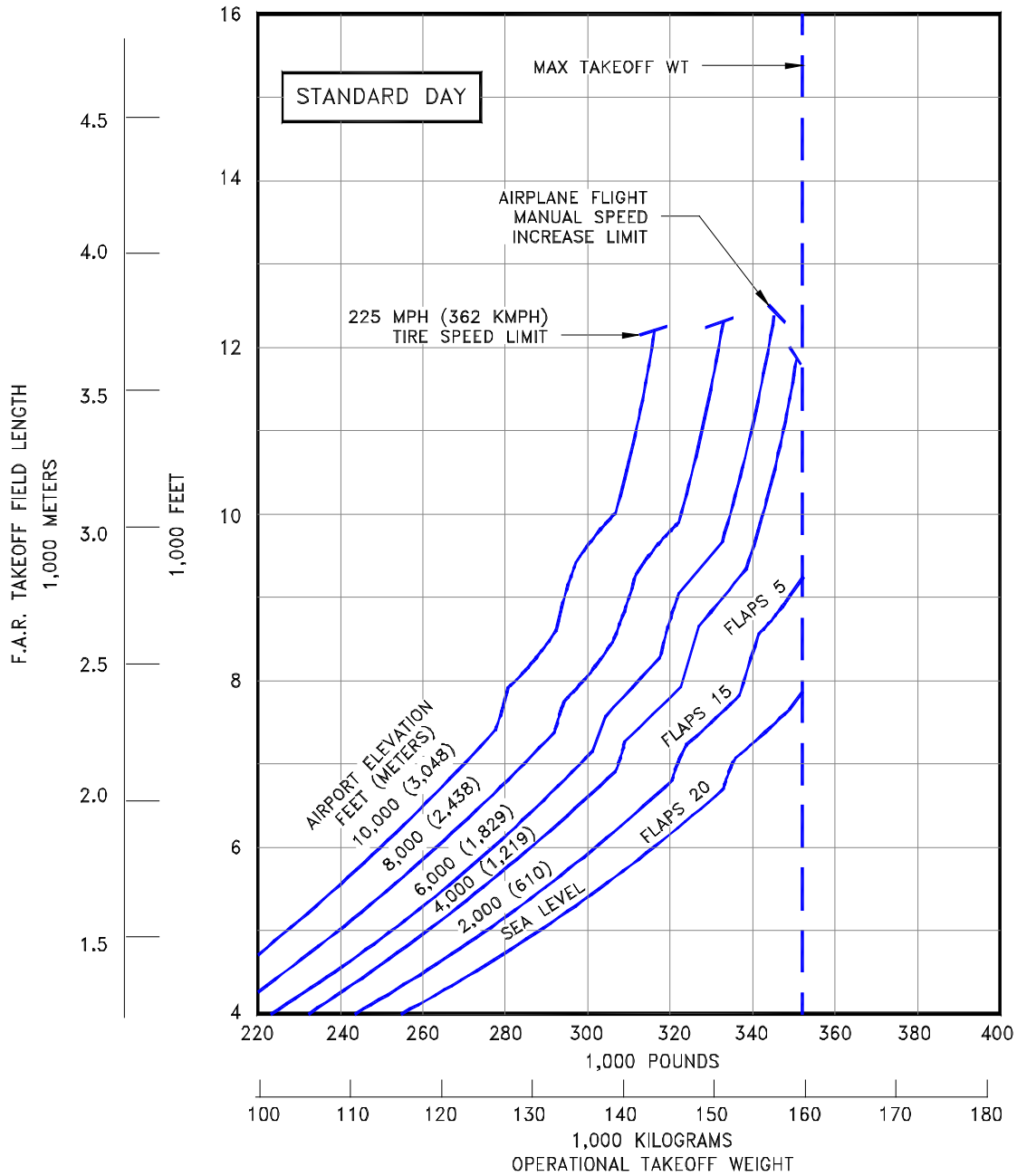

3.3.12 FAA/EASA Takeoff Runway Length Requirements - Standard Day + 31°F (STD Day + 17°C): Model 767-300 (CF6-80C2B2, PW4052 Engines)

NOTES:

- CF6-80C2B2, PW4052 ENGINES
- ZERO RUNWAY GRADIENT
- ZERO WIND
- AIR CONDITIONING OFF
- CONSULT USING AIRLINE FOR SPECIFIC OPERATING PROCEDURE PRIOR TO FACILITY DESIGN

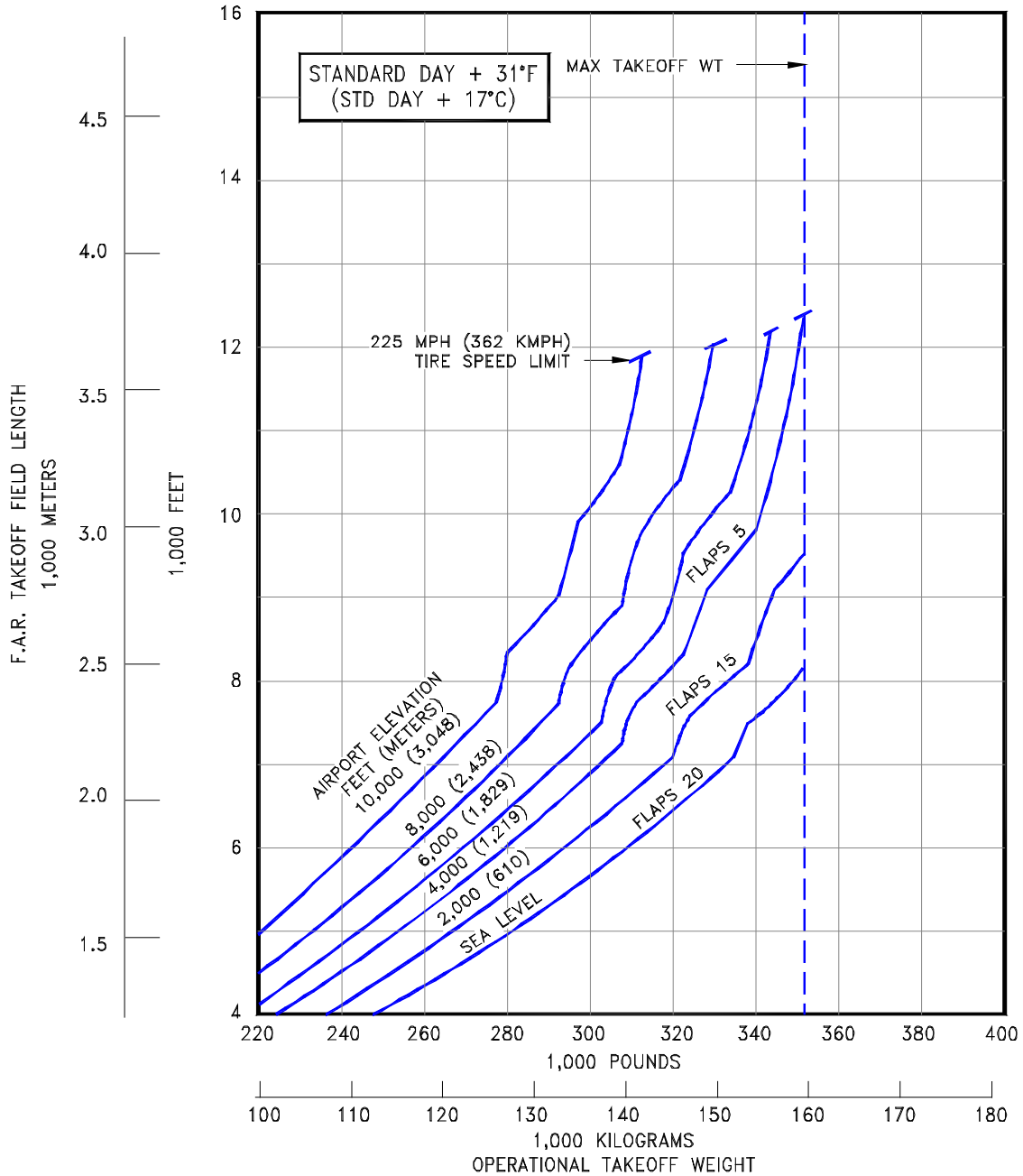

3.3.13 FAA/EASA Takeoff Runway Length Requirements – Standard Day: Model 767-300ER, -300 Freighter (CF6-80C2B4, PW4056, RB211-524G Engines)

NOTES:

- CF6-80C2B4, PW4056, RB211-524G ENGINES
- ZERO RUNWAY GRADIENT
- ZERO WIND
- AIR CONDITIONING OFF
- CONSULT USING AIRLINE FOR SPECIFIC OPERATING PROCEDURE PRIOR TO FACILITY DESIGN

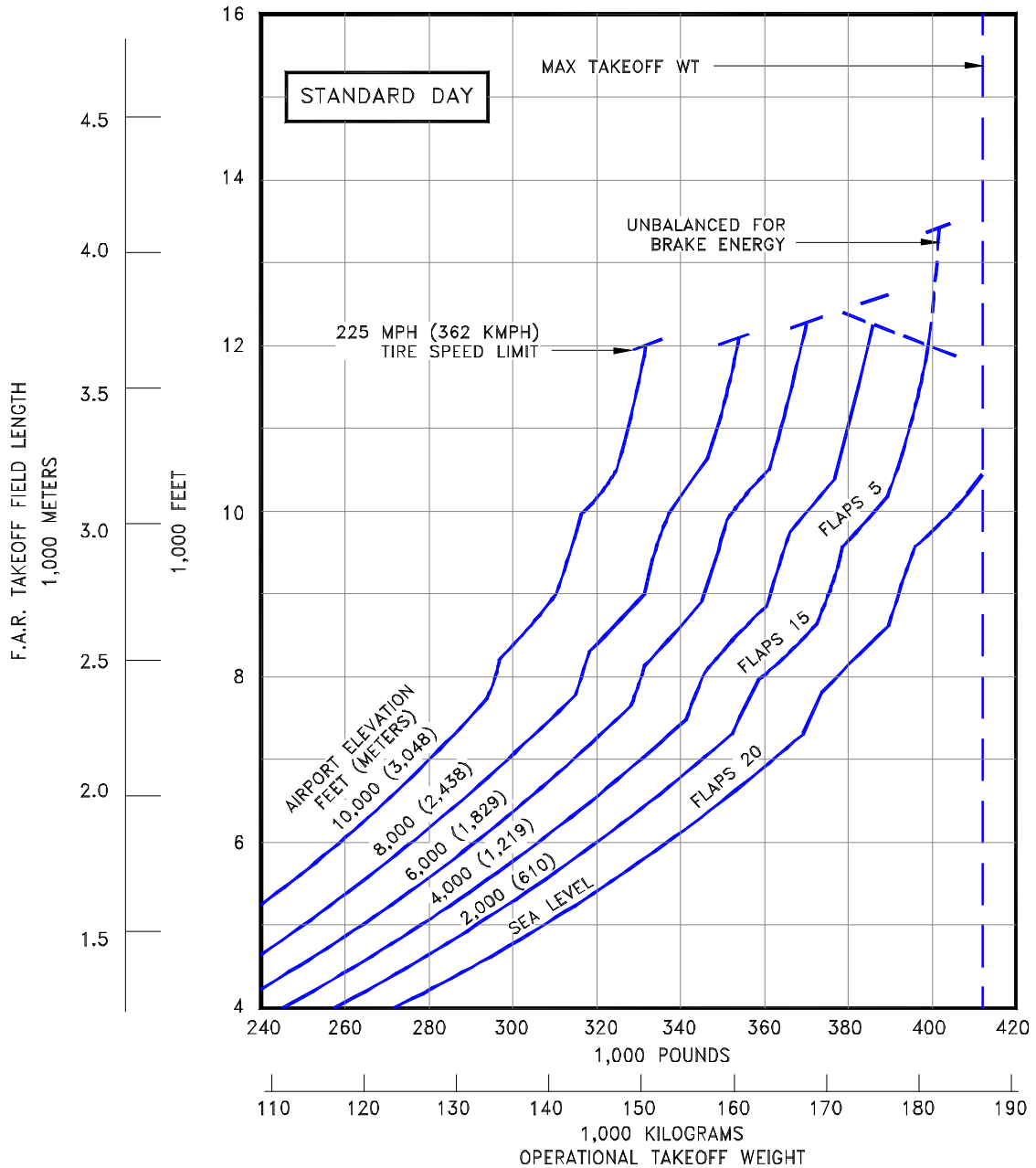

D6-58328

REV I

July 2021

3-24

3.3.14 FAA/EASA Takeoff Runway Length Requirements - Standard Day + 31°F (STD + 17°C): Model 767-300ER, -300 Freighter (CF6-80C2B4, PW4052, RB211-524G Engines)

NOTES:

- CF6-80C2B4, PW4052, RB211-524G ENGINES
- ZERO RUNWAY GRADIENT
- ZERO WIND
- AIR CONDITIONING OFF
- CONSULT USING AIRLINE FOR SPECIFIC OPERATING PROCEDURE PRIOR TO FACILITY DESIGN

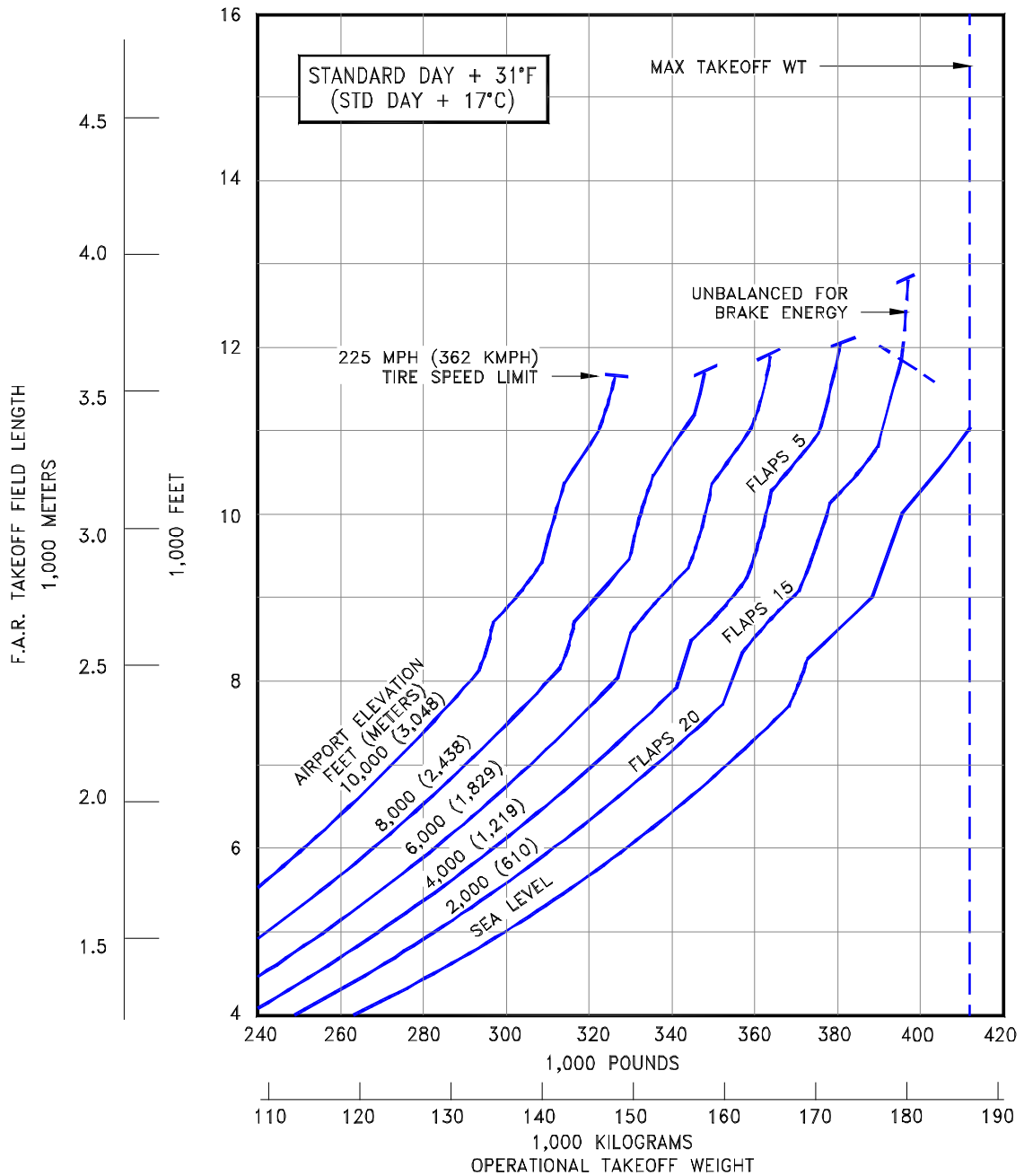

D6-58328

REV I

July 2021

3-25

3.3.15 FAA/EASA Takeoff Runway Length Requirements – Standard Day: Model 767-300ER, -300 Freighter (CF6-80C2B64, PW4060, RB211-524H Engines)

NOTES:

- CF6-80C2B6, PW4060, RB211-524H ENGINES
- ZERO RUNWAY GRADIENT
- ZERO WIND
- AIR CONDITIONING OFF
- CONSULT USING AIRLINE FOR SPECIFIC OPERATING PROCEDURE PRIOR TO FACILITY DESIGN

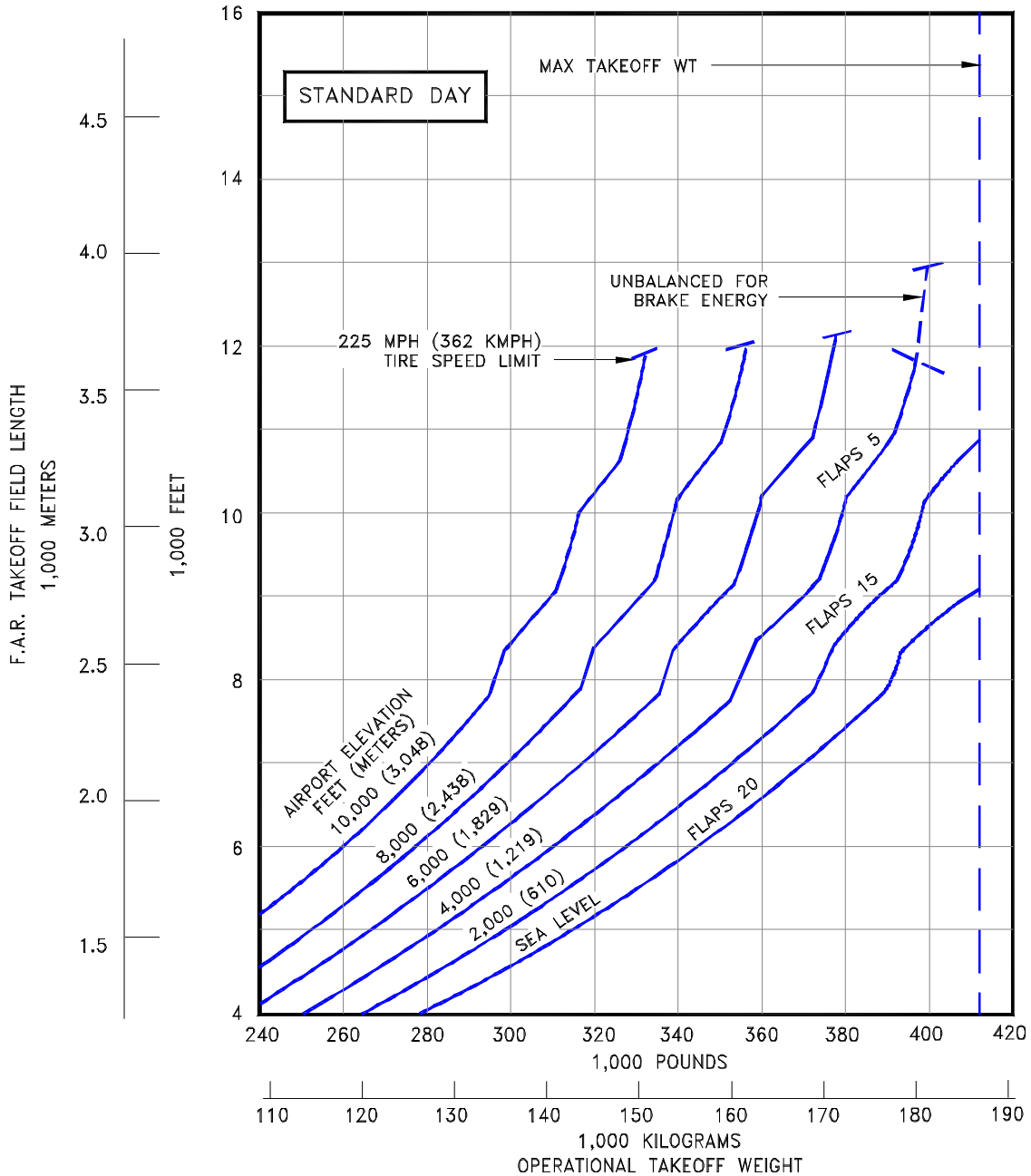

3.3.16 FAA/EASA Takeoff Runway Length Requirements - Standard Day + 27°F (STD + 15°C): Model 767-300ER, -300 Freighter (CF6-80C2B6, PW4060, RB211-524H Engines)

- NOTES:
- CF6-80C2B6, PW4060, RB211-524H ENGINES
 - ZERO RUNWAY GRADIENT
 - ZERO WIND
 - AIR CONDITIONING OFF
 - CONSULT USING AIRLINE FOR SPECIFIC OPERATING PROCEDURE PRIOR TO FACILITY DESIGN

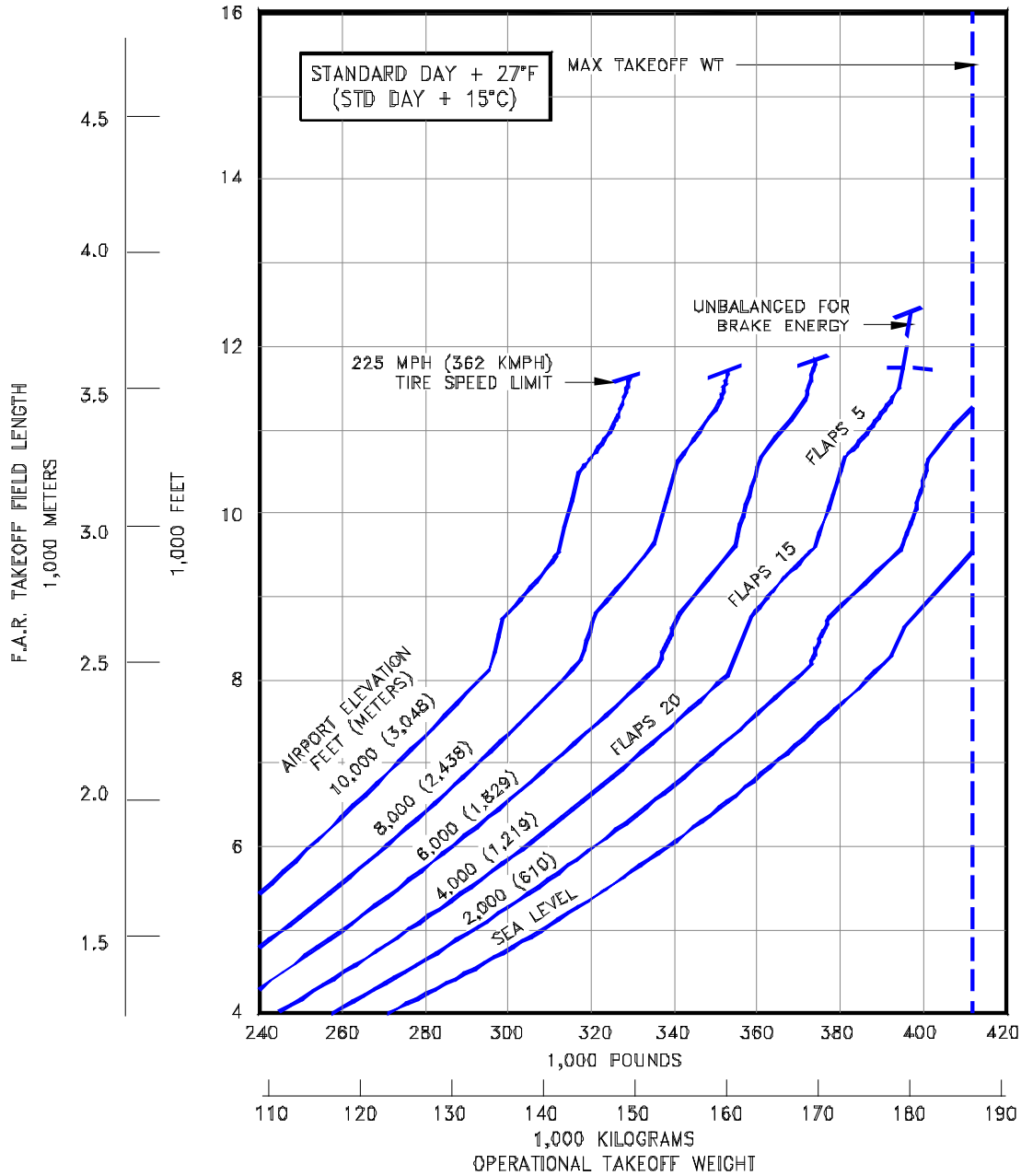

3.3.17 FAA/EASA Takeoff Runway Length Requirements - Standard Day: Model 767-300ER (CF6-80C2B7F Engines)

NOTES:

- CF6-80C2B7F ENGINES
- ZERO RUNWAY GRADIENT
- ZERO WIND
- AIR CONDITIONING OFF
- CONSULT USING AIRLINE FOR SPECIFIC OPERATING PROCEDURE PRIOR TO FACILITY DESIGN

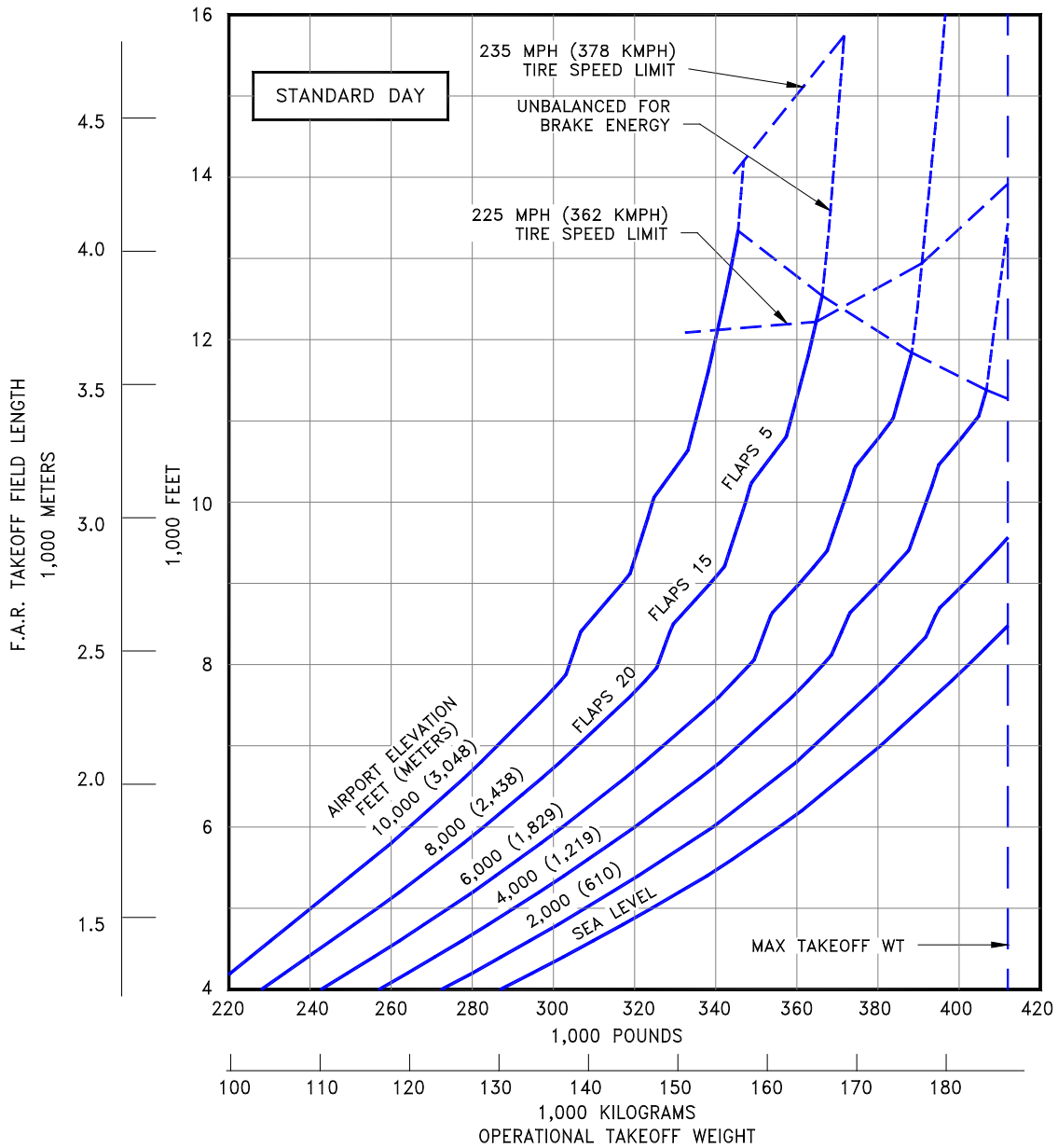

3.3.18 FAA/EASA Takeoff Runway Length Requirements - Standard Day + 27°F (STD + 15°C): Model 767-300ER (CF6-80C2B7F Engines)

NOTES:

- CF6-80C2B7F ENGINES
- ZERO RUNWAY GRADIENT
- ZERO WIND
- AIR CONDITIONING OFF
- CONSULT USING AIRLINE FOR SPECIFIC OPERATING PROCEDURE PRIOR TO FACILITY DESIGN

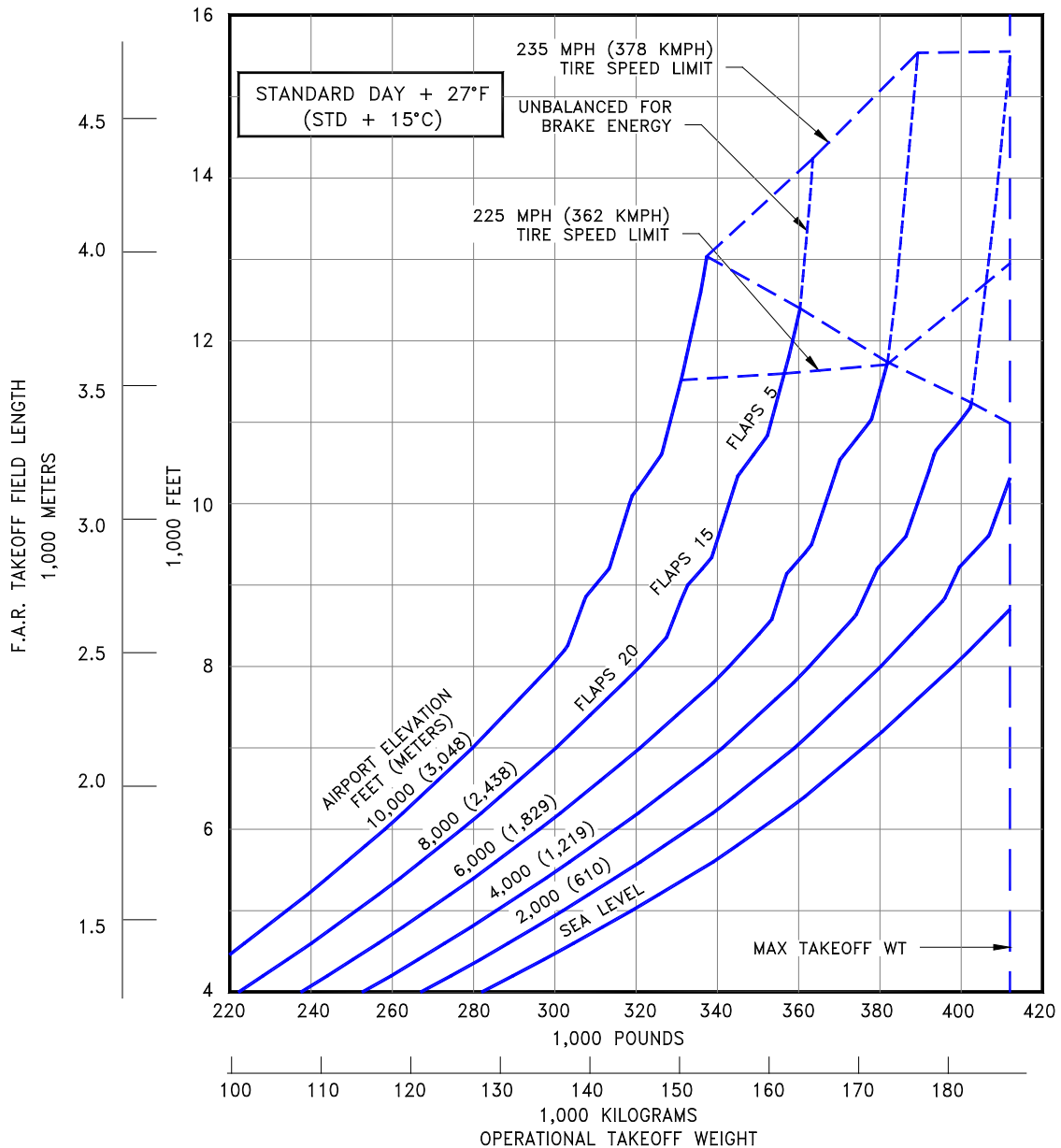

D6-58328

REV I

July 2021

3-29

3.3.19 FAA/EASA Takeoff Runway Length Requirements - Standard Day: Model 767-300ER (PW4062 Engines)

NOTES:

- PW4062 ENGINES
- ZERO RUNWAY GRADIENT
- ZERO WIND
- AIR CONDITIONING OFF
- CONSULT USING AIRLINE FOR SPECIFIC OPERATING PROCEDURE PRIOR TO FACILITY DESIGN

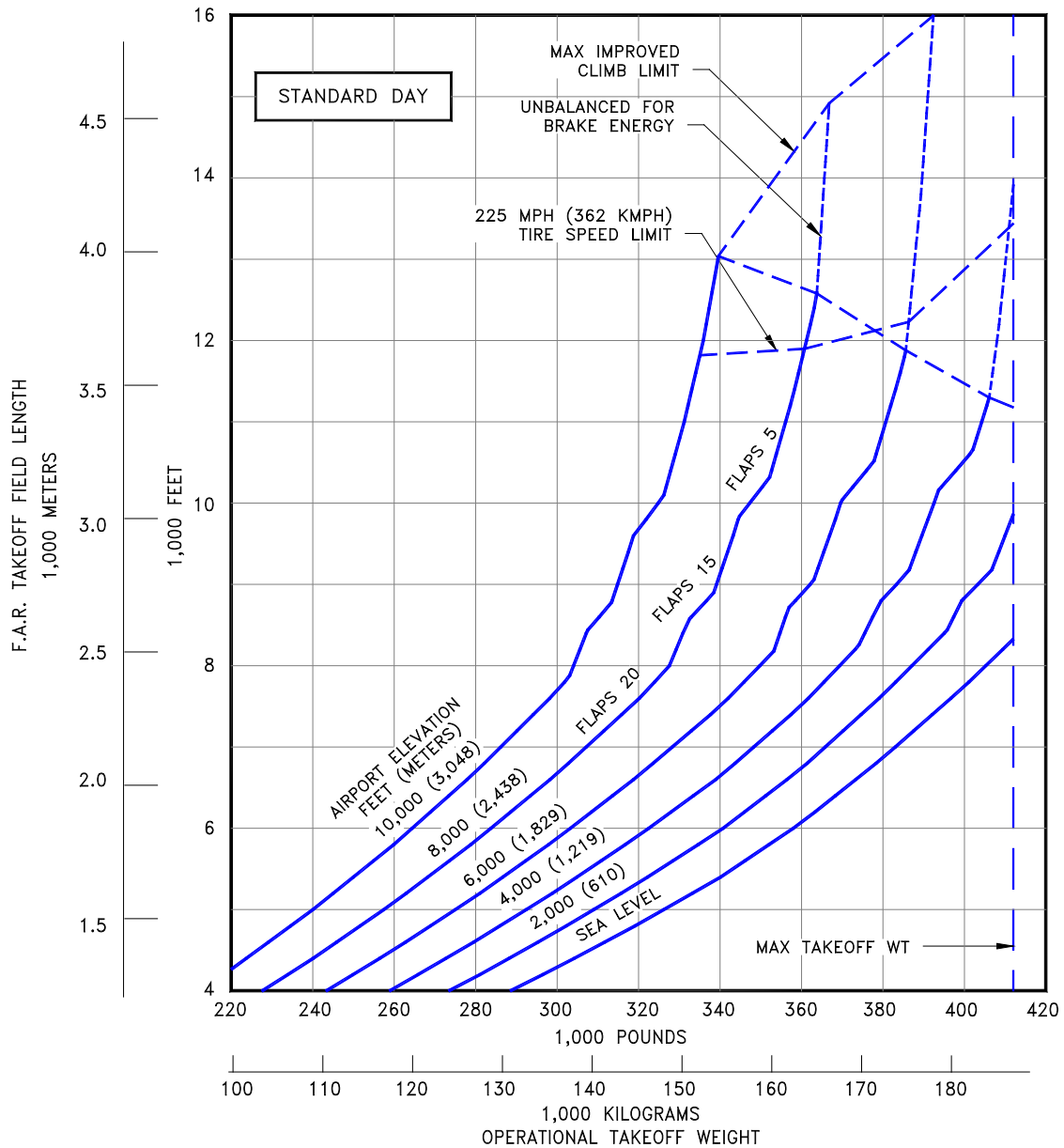

3.3.20 FAA/EASA Takeoff Runway Length Requirements - Standard Day + 27°F (STD + 15°C): Model 767-300ER (PW4062 Engines)

NOTES:

- PW4062 ENGINES
- ZERO RUNWAY GRADIENT
- ZERO WIND
- AIR CONDITIONING OFF
- CONSULT USING AIRLINE FOR SPECIFIC OPERATING PROCEDURE PRIOR TO FACILITY DESIGN

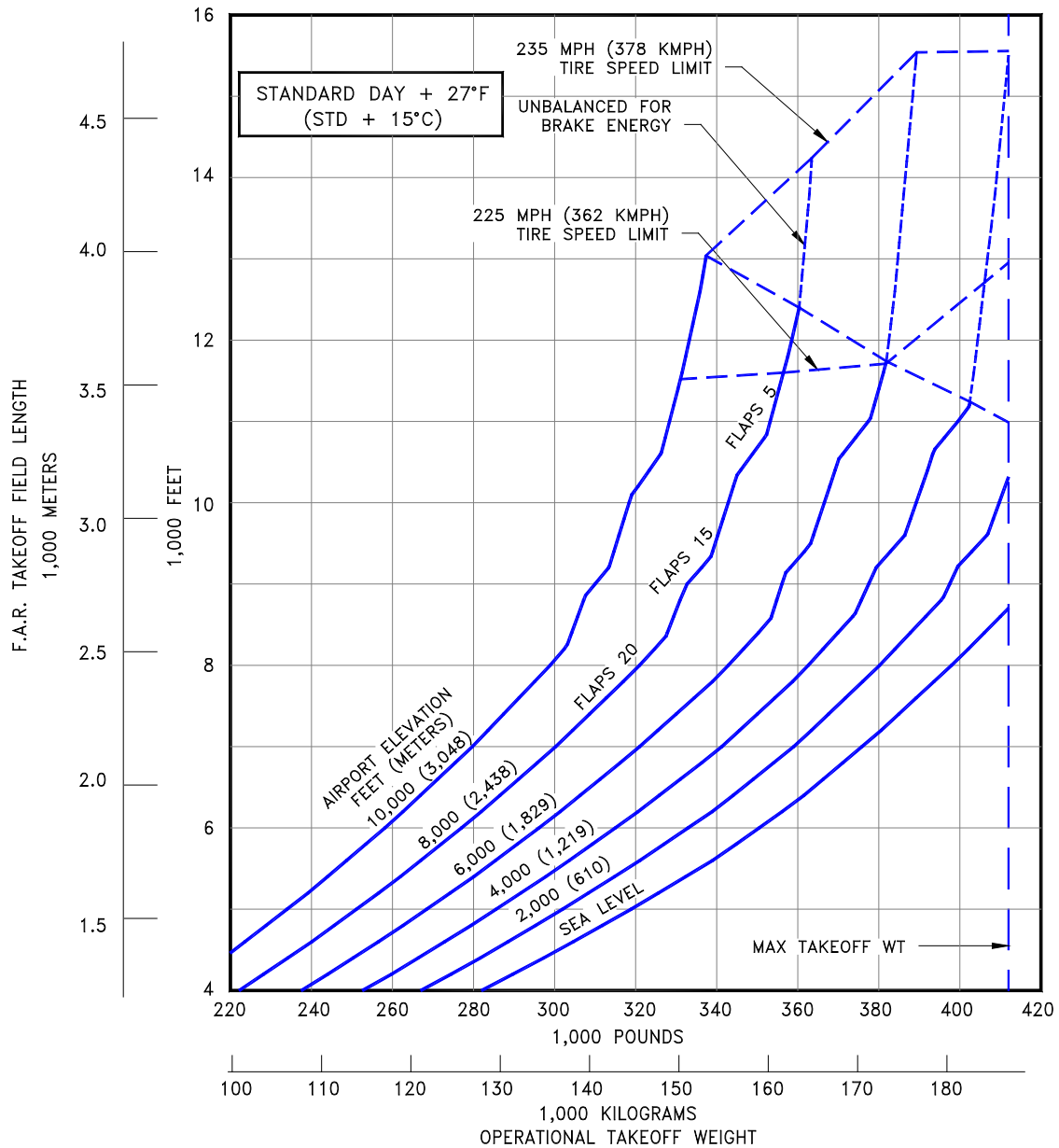

3.3.21 FAA/EASA Takeoff Runway Length Requirements - Standard Day: Model 767-300 Freighter (CF6-80C2B7F Engines)

NOTES:

- CF6-80C2B7F ENGINES
- ZERO RUNWAY GRADIENT
- ZERO WIND
- AIR CONDITIONING OFF
- CONSULT USING AIRLINE FOR SPECIFIC OPERATING PROCEDURE PRIOR TO FACILITY DESIGN

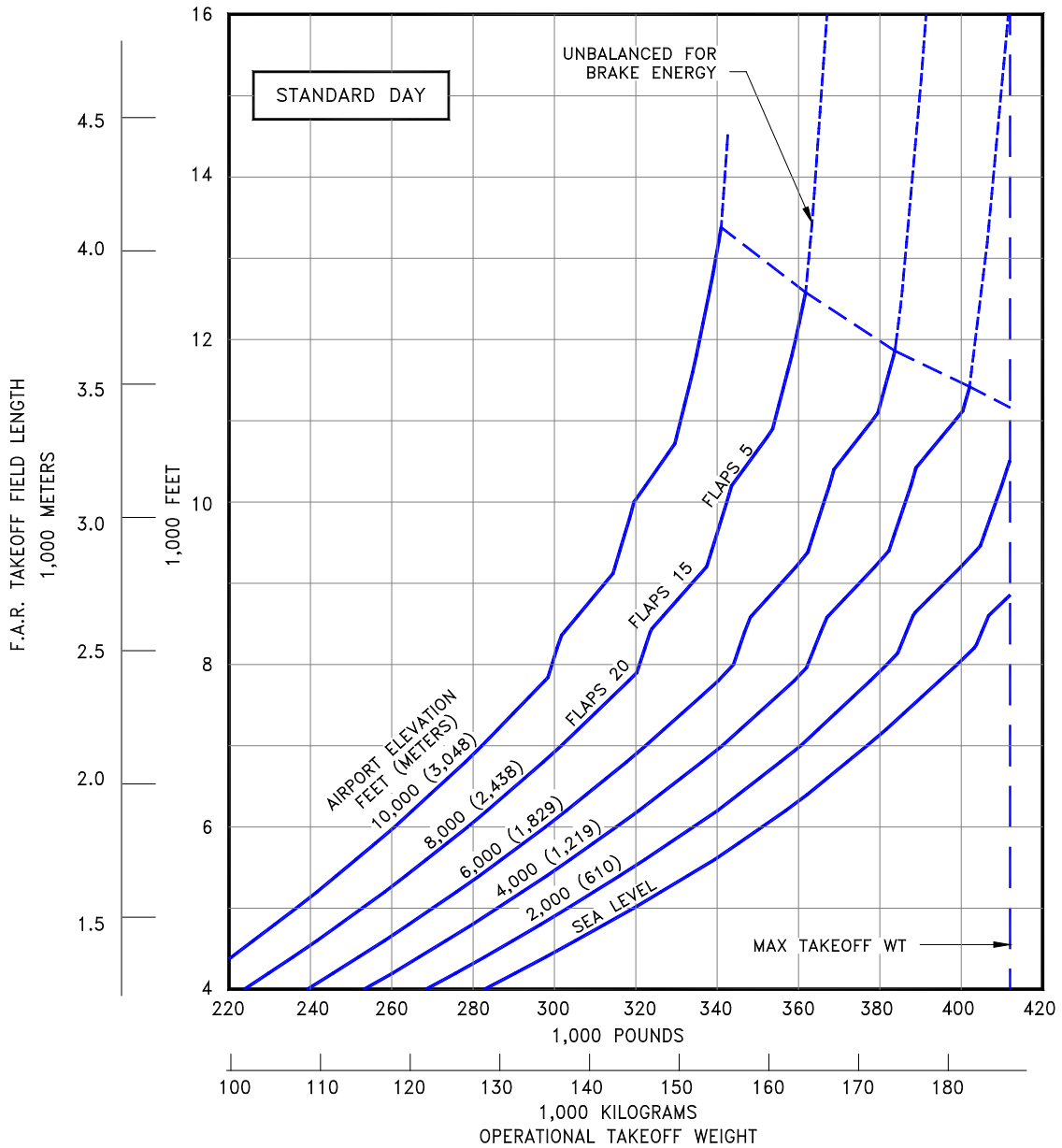

3.3.22 FAA/EASA Takeoff Runway Length Requirements - Standard Day + 27°F (STD + 15°C): Model 767-300 Freighter, (CF6-80C2B7F Engines)

NOTES:

- CF6-80C2B7F ENGINES
- ZERO RUNWAY GRADIENT
- ZERO WIND
- AIR CONDITIONING OFF
- CONSULT USING AIRLINE FOR SPECIFIC OPERATING PROCEDURE PRIOR TO FACILITY DESIGN

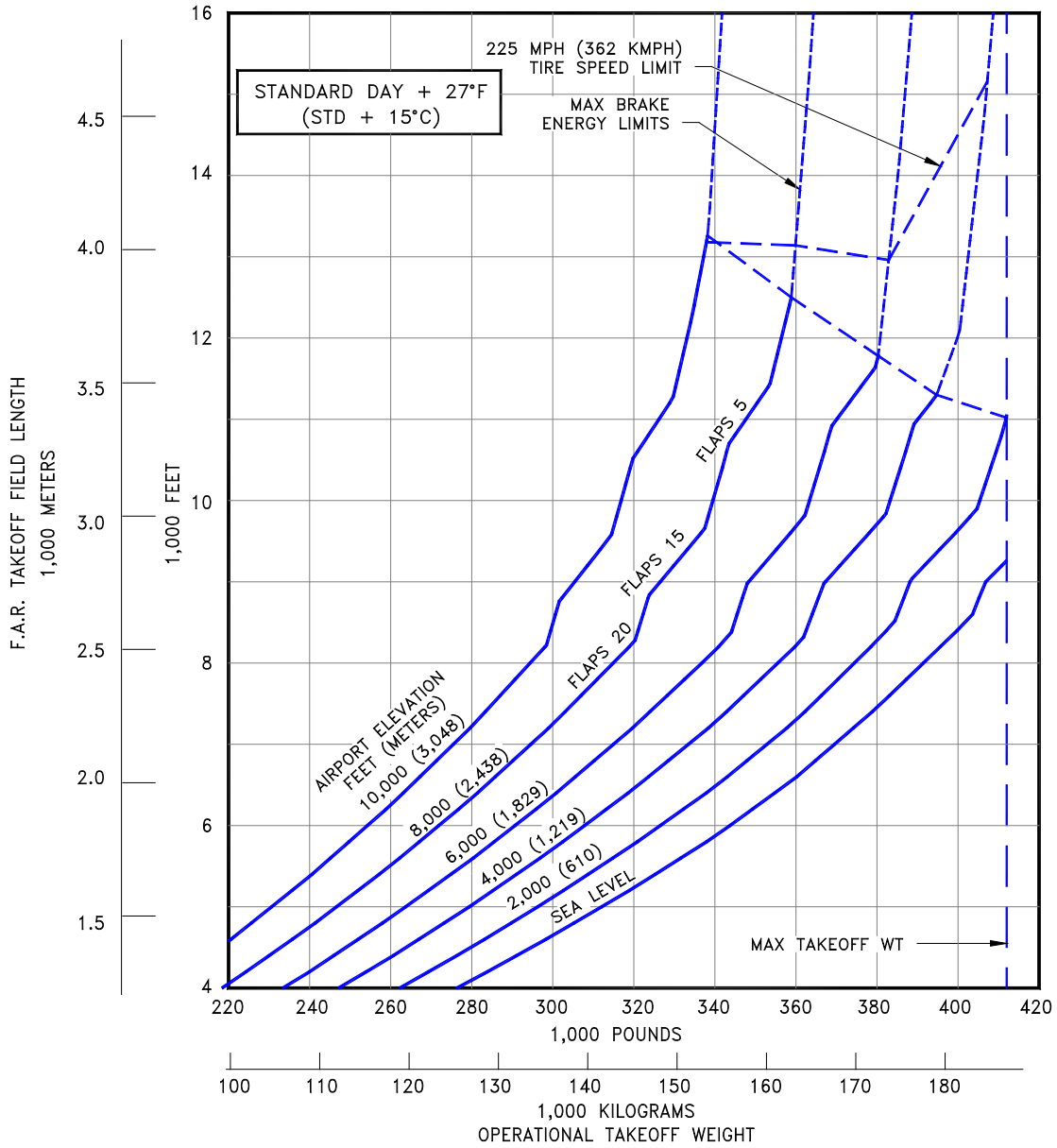

3.3.23 FAA/EASA Takeoff Runway Length Requirements - Standard Day: Model 767-300 Freighter (PW4062 Engines)

NOTES:

- PW4062 ENGINES
- ZERO RUNWAY GRADIENT
- ZERO WIND
- AIR CONDITIONING OFF
- CONSULT USING AIRLINE FOR SPECIFIC OPERATING PROCEDURE PRIOR TO FACILITY DESIGN

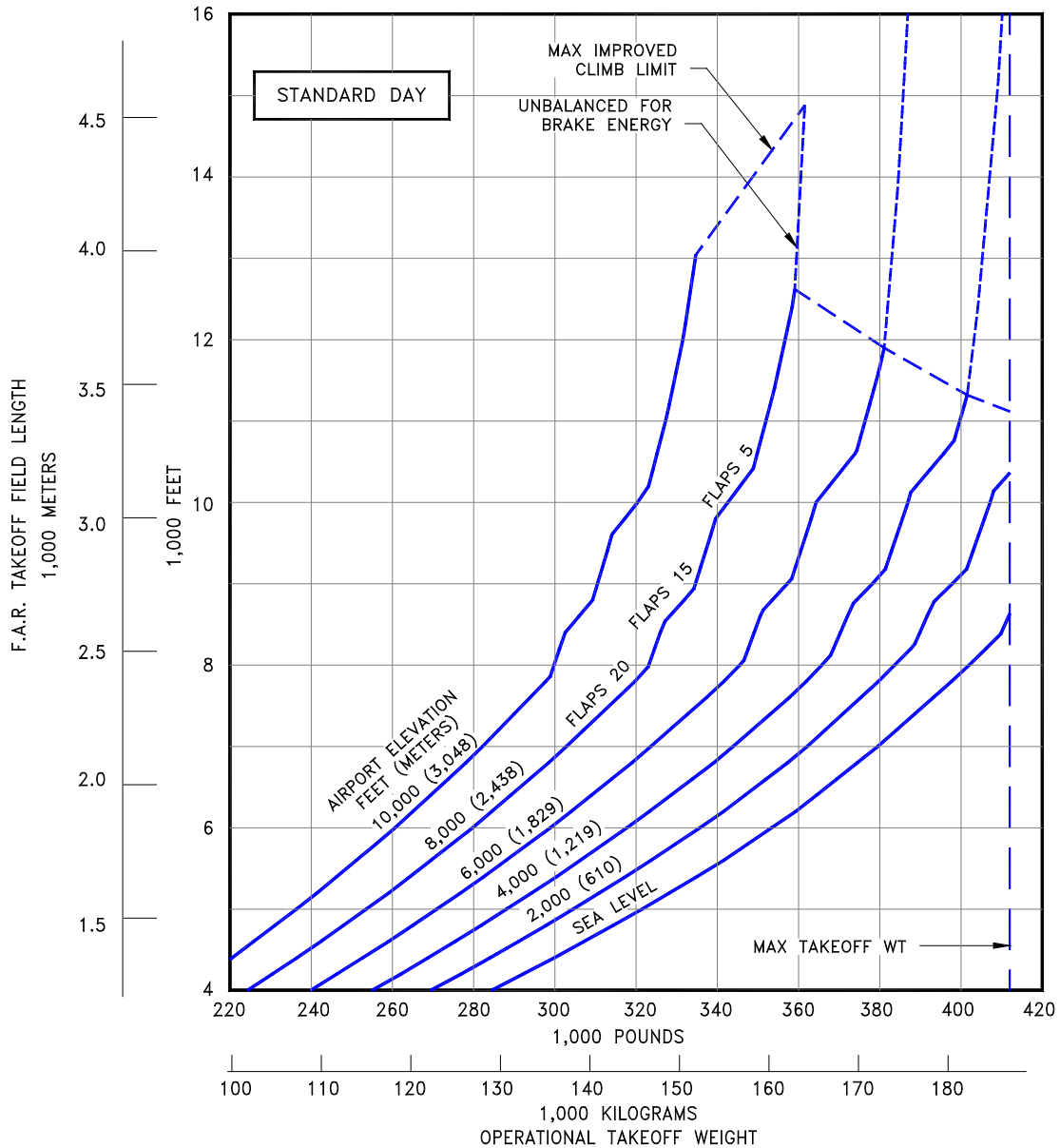

3.3.24 FAA/EASA Takeoff Runway Length Requirements - Standard Day + 27°F (STD + 15°C): Model 767-300 Freighter (PW4062 Engines)

NOTES:

- PW4062 ENGINES
- ZERO RUNWAY GRADIENT
- ZERO WIND
- AIR CONDITIONING OFF
- CONSULT USING AIRLINE FOR SPECIFIC OPERATING PROCEDURE PRIOR TO FACILITY DESIGN

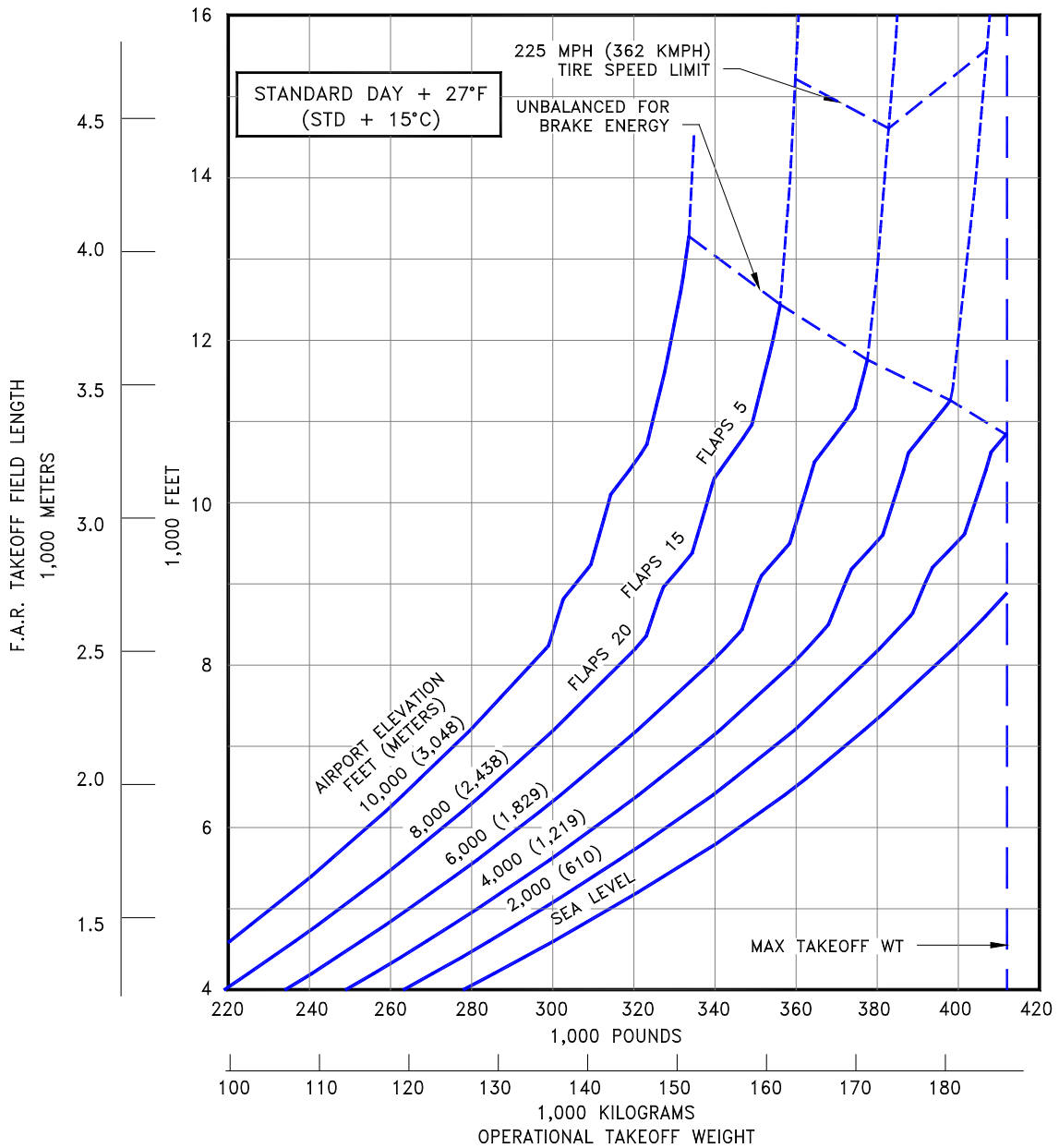

3.3.25 FAA/EASA Takeoff Runway Length Requirements - Standard Day, Dry Runway Surface: Model 767-400ER (CF6-80C2B8F Engines)

NOTES:

- CF6-80C2B8F ENGINES
- NO ENGINE AIRBLEED FOR AIR CONDITIONING
- ZERO WIND, ZERO RUNWAY GRADIENT
- DRY RUNWAY SURFACE
- CONSULT USING AIRLINE FOR SPECIFIC OPERATING PROCEDURE PRIOR TO FACILITY DESIGN

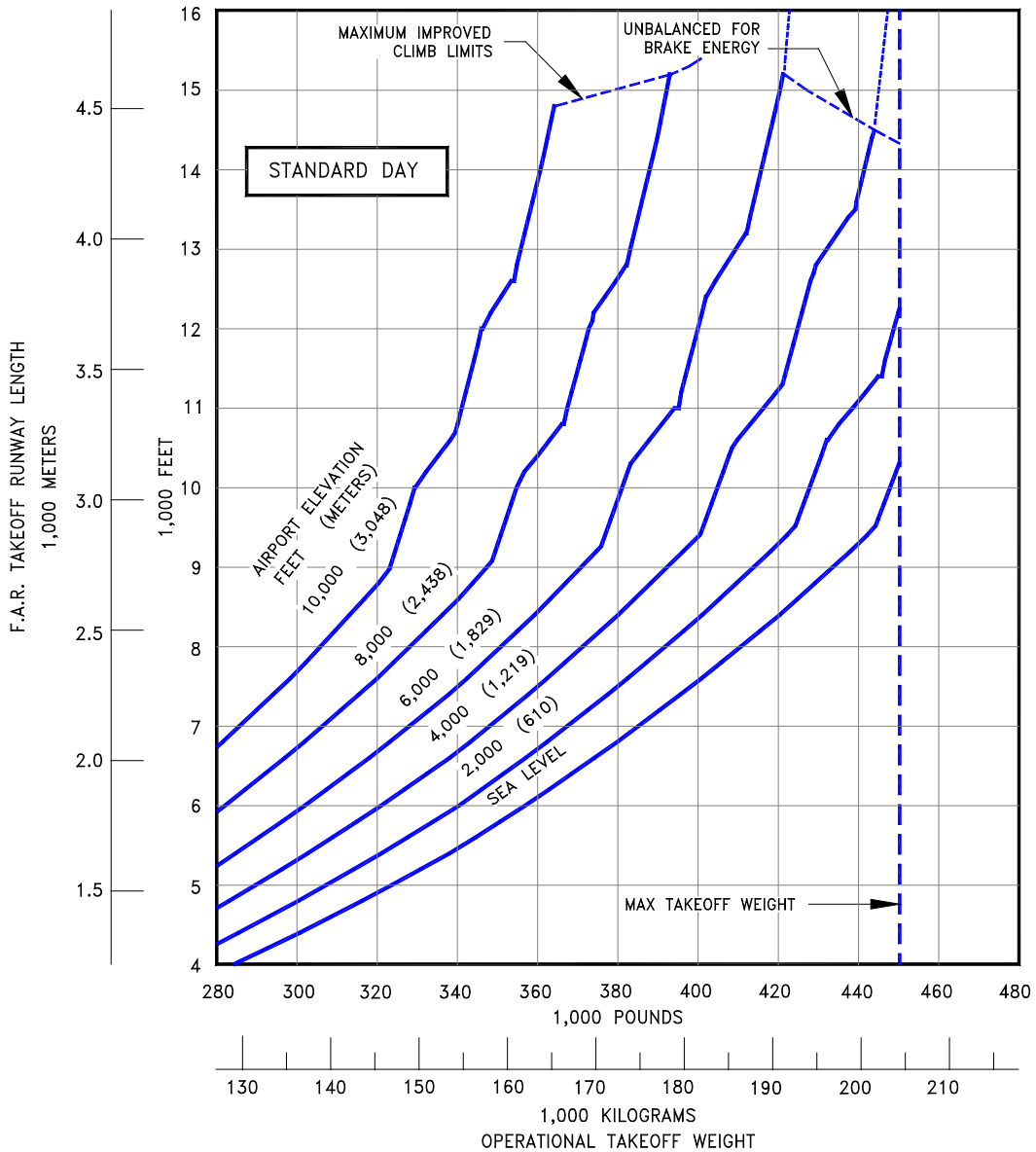

3.3.26 FAA/EASA Takeoff Runway Length Requirements - Standard Day + 31°F (STD + 17°C), Dry Runway Surface: Model 767-400ER (CF6-80C2B8F Engines)

NOTES:

- CF6-80C2B8F ENGINES
- NO ENGINE AIRBLEED FOR AIR CONDITIONING
- ZERO WIND, ZERO RUNWAY GRADIENT
- DRY RUNWAY SURFACE
- CONSULT USING AIRLINE FOR SPECIFIC OPERATING PROCEDURE PRIOR TO FACILITY DESIGN

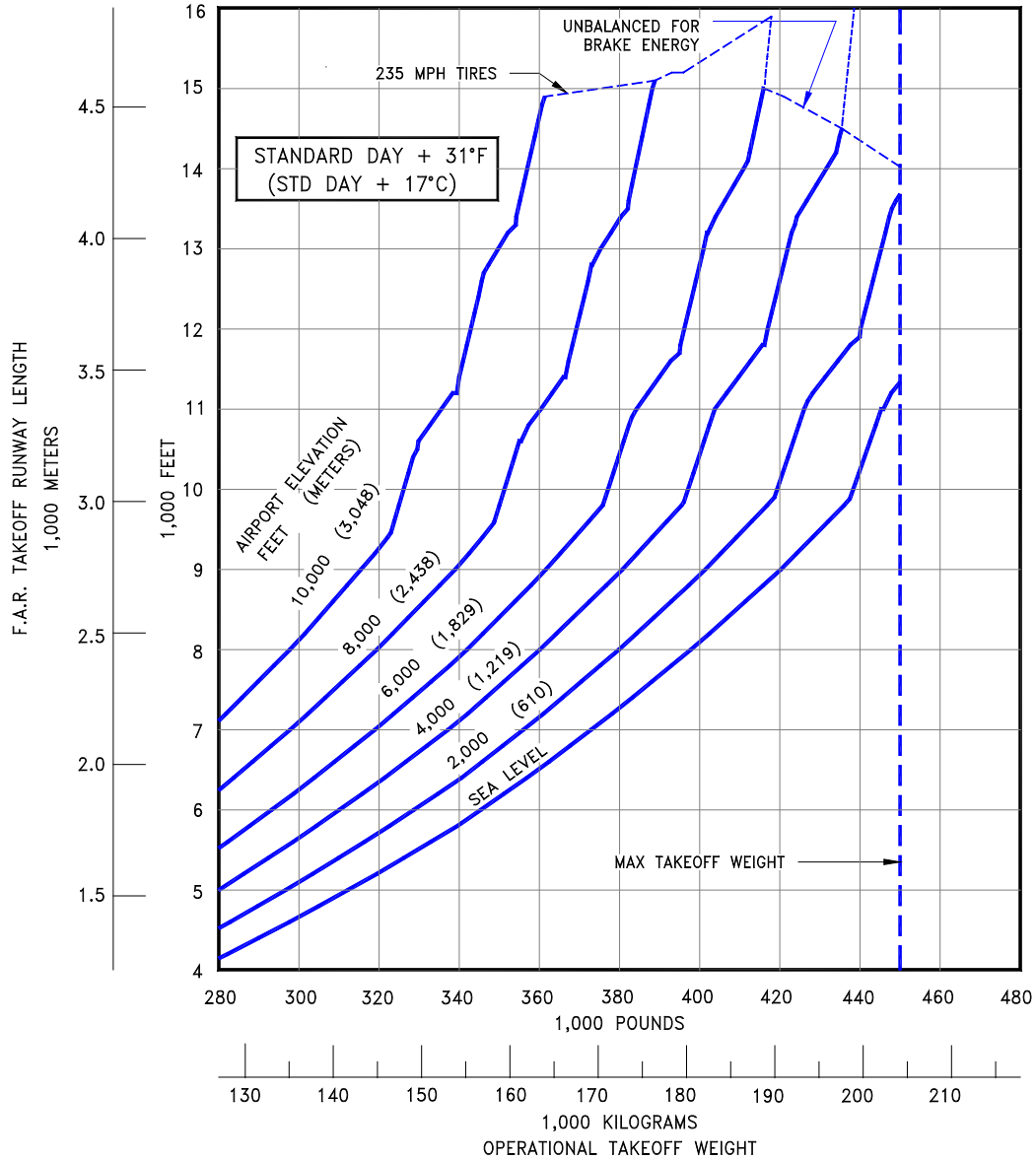

3.3.27 FAA/EASA Takeoff Runway Length Requirements - Standard Day, Wet Smooth Runway Surface: Model 767-400ER (CF6-80C2B8F Engines)

NOTES:

- CF6-80C2B8F ENGINES
- NO ENGINE AIRBLED FOR AIR CONDITIONING
- ZERO WIND, ZERO RUNWAY GRADIENT
- WET SMOOTH RUNWAY SURFACE
- CONSULT USING AIRLINE FOR SPECIFIC OPERATING PROCEDURE PRIOR TO FACILITY DESIGN

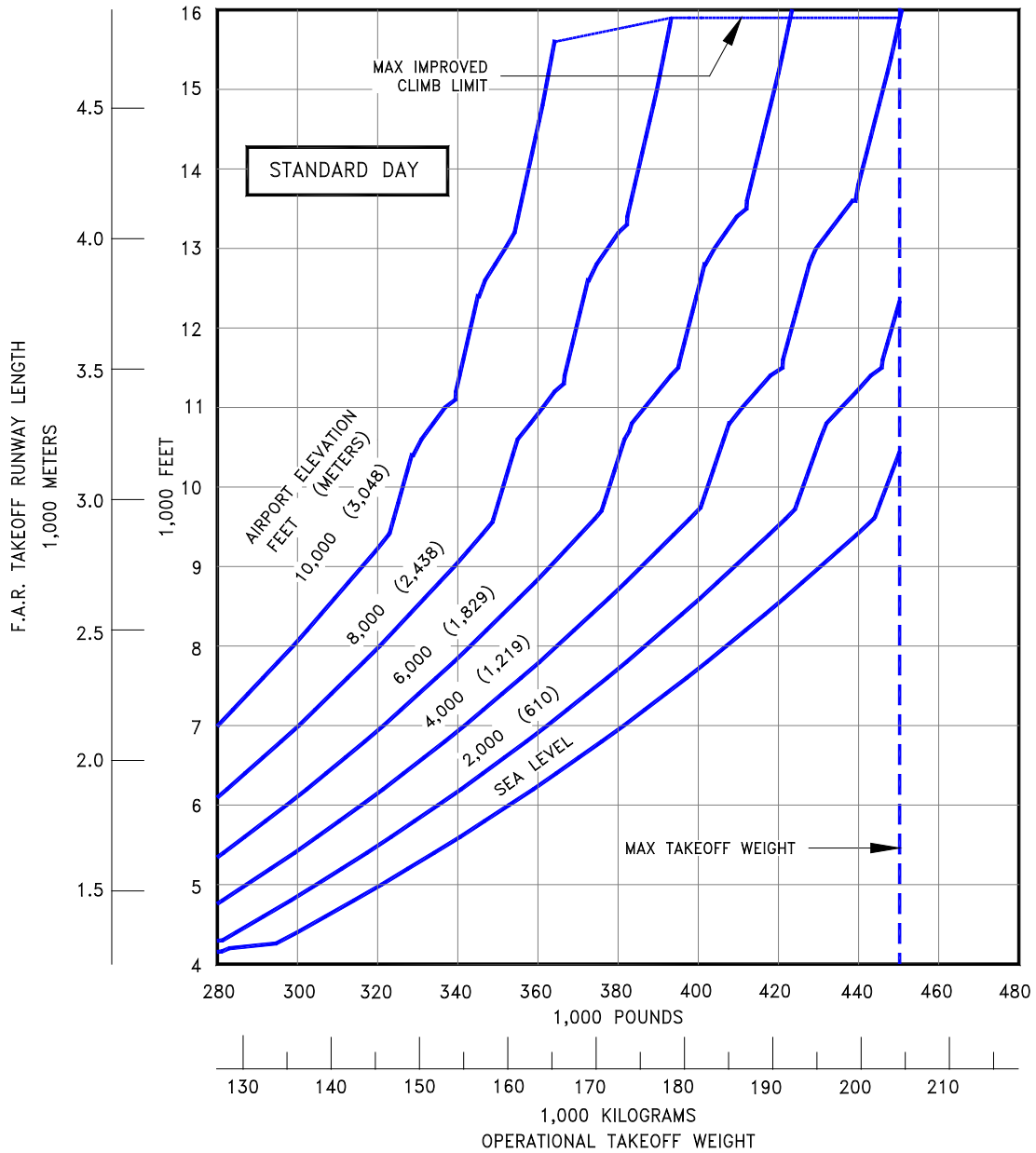

3.3.28 FAA/EASA Takeoff Runway Length Requirements - Standard Day + 27°F (STD + 15°C), Wet Smooth Runway Surface: Model 767-400ER (CF6-80C2B8F Engines)

NOTES:

- CF6-80C2B8F ENGINES
- NO ENGINE AIRBLEED FOR AIR CONDITIONING
- ZERO WIND, ZERO RUNWAY GRADIENT
- WET SMOOTH RUNWAY SURFACE
- CONSULT USING AIRLINE FOR SPECIFIC OPERATING PROCEDURE PRIOR TO FACILITY DESIGN

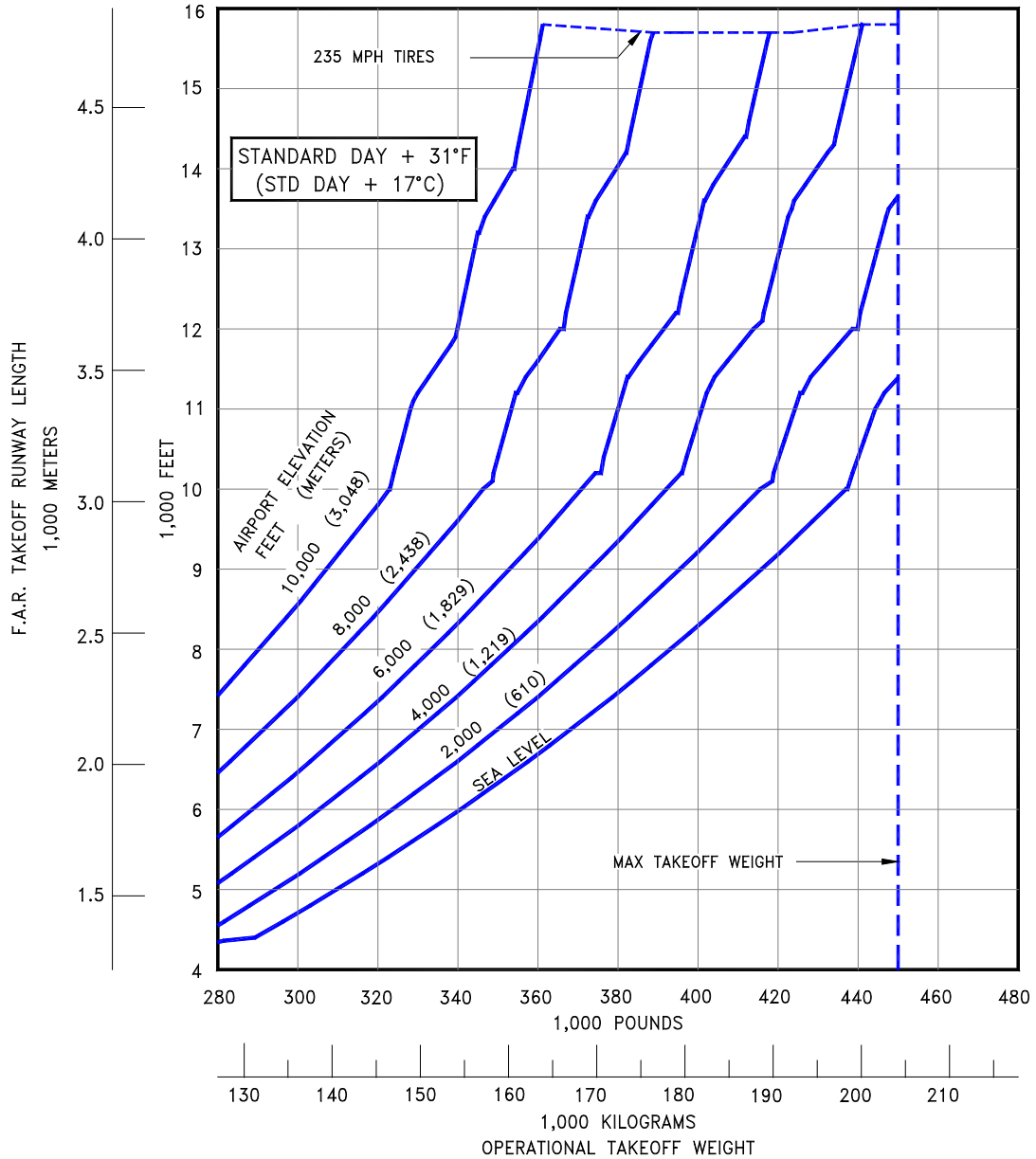

3.3.29 FAA/EASA Takeoff Runway Length Requirements - Standard Day, Dry Runway Surface: Model 767-400ER (CF6-80C2B7F1 Engines)

NOTES:

- CF6-80C2B7F1 ENGINES
- NO ENGINE AIRBLEED FOR AIR CONDITIONING
- ZERO WIND, ZERO RUNWAY GRADIENT
- DRY RUNWAY SURFACE
- CONSULT USING AIRLINE FOR SPECIFIC OPERATING PROCEDURE PRIOR TO FACILITY DESIGN

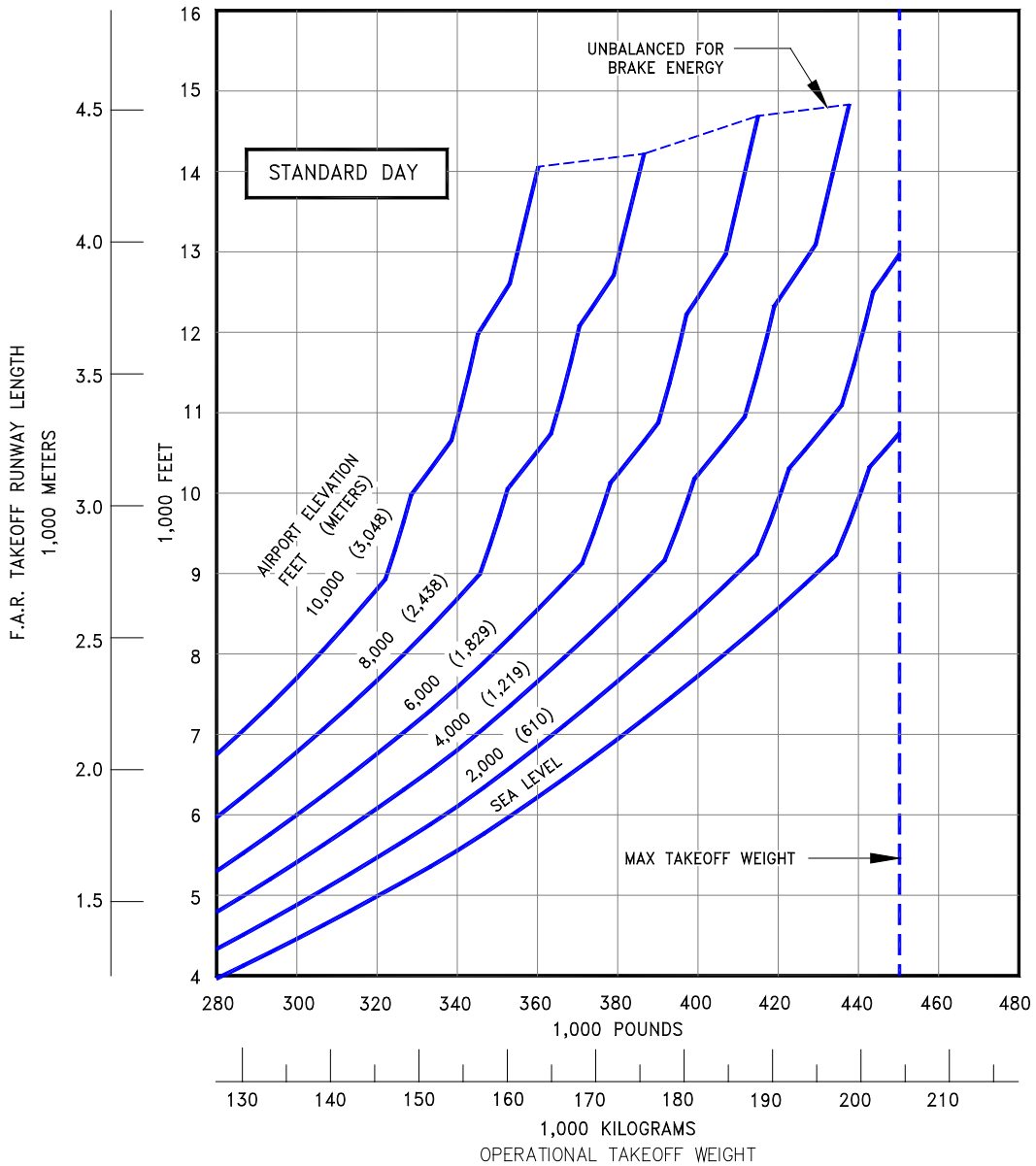

3.3.30 FAA/EASA Takeoff Runway Length Requirements - Standard Day + 27°F (STD + 15°C), Dry Runway Surface: Model 767-400ER (CF6-80C2B7F1 Engines)

NOTES:

- CF6-80C2B7F1 ENGINES
- NO ENGINE AIRBLEED FOR AIR CONDITIONING
- ZERO WIND, ZERO RUNWAY GRADIENT
- DRY RUNWAY SURFACE
- CONSULT USING AIRLINE FOR SPECIFIC OPERATING PROCEDURE PRIOR TO FACILITY DESIGN

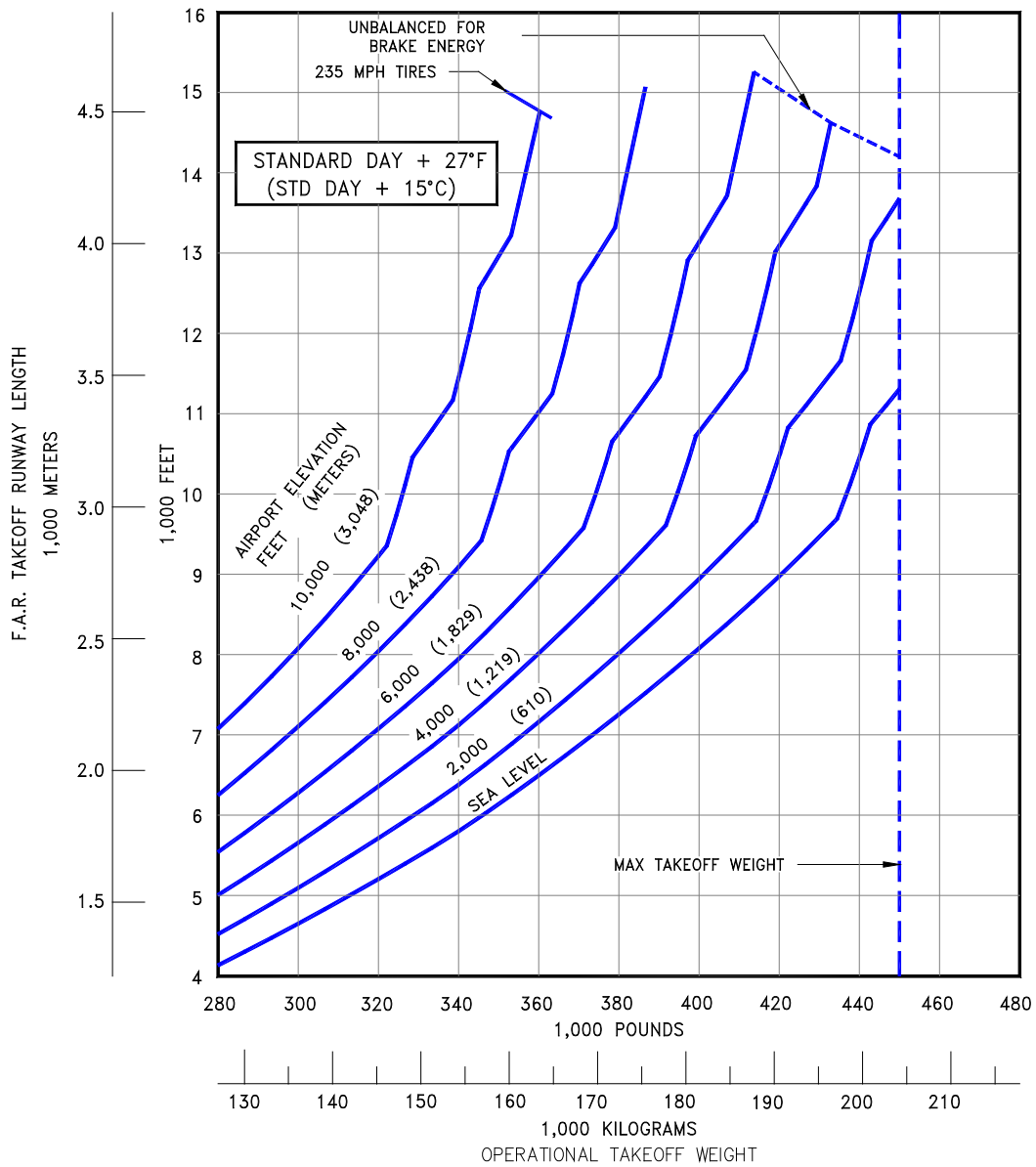

3.3.31 FAA/EASA Takeoff Runway Length Requirements - Standard Day, Wet Smooth Runway Surface: Model 767-400ER (CF6-80C2B7F1 Engines)

NOTES:

- CF6-80C2B7F1 ENGINES
- NO ENGINE AIRBLEED FOR AIR CONDITIONING
- ZERO WIND, ZERO RUNWAY GRADIENT
- WET SMOOTH RUNWAY SURFACE
- CONSULT USING AIRLINE FOR SPECIFIC OPERATING PROCEDURE PRIOR TO FACILITY DESIGN

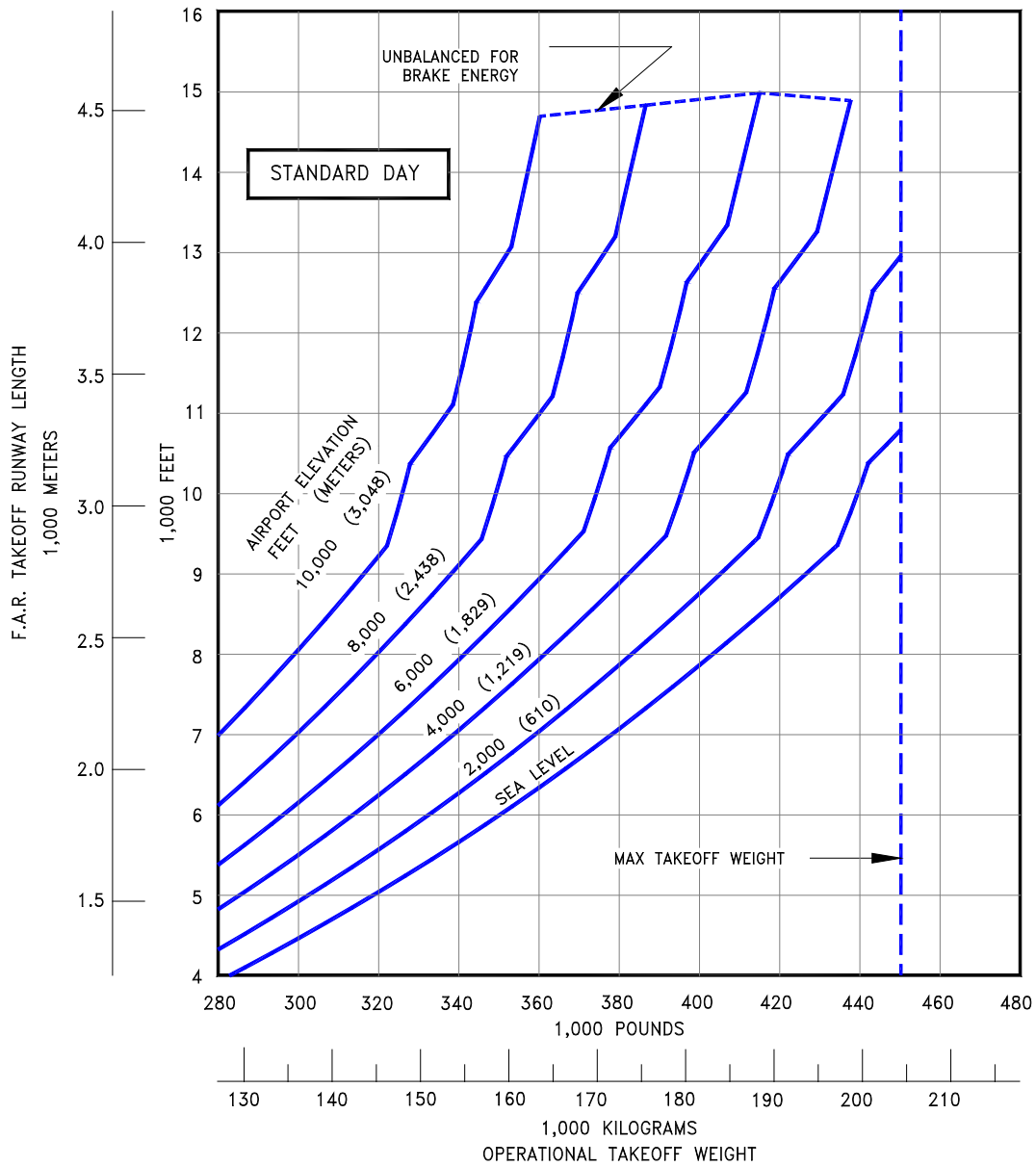

3.3.32 FAA/EASA Takeoff Runway Length Requirements - Standard Day + 27°F (STD + 15°C), Wet Smooth Runway Surface: Model 767-400ER (CF6-80C2B7F1 Engines)

NOTES:

- CF6-80C2B7F1 ENGINES
- NO ENGINE AIRBLEED FOR AIR CONDITIONING
- ZERO WIND, ZERO RUNWAY GRADIENT
- WET SMOOTH RUNWAY SURFACE
- CONSULT USING AIRLINE FOR SPECIFIC OPERATING PROCEDURE PRIOR TO FACILITY DESIGN

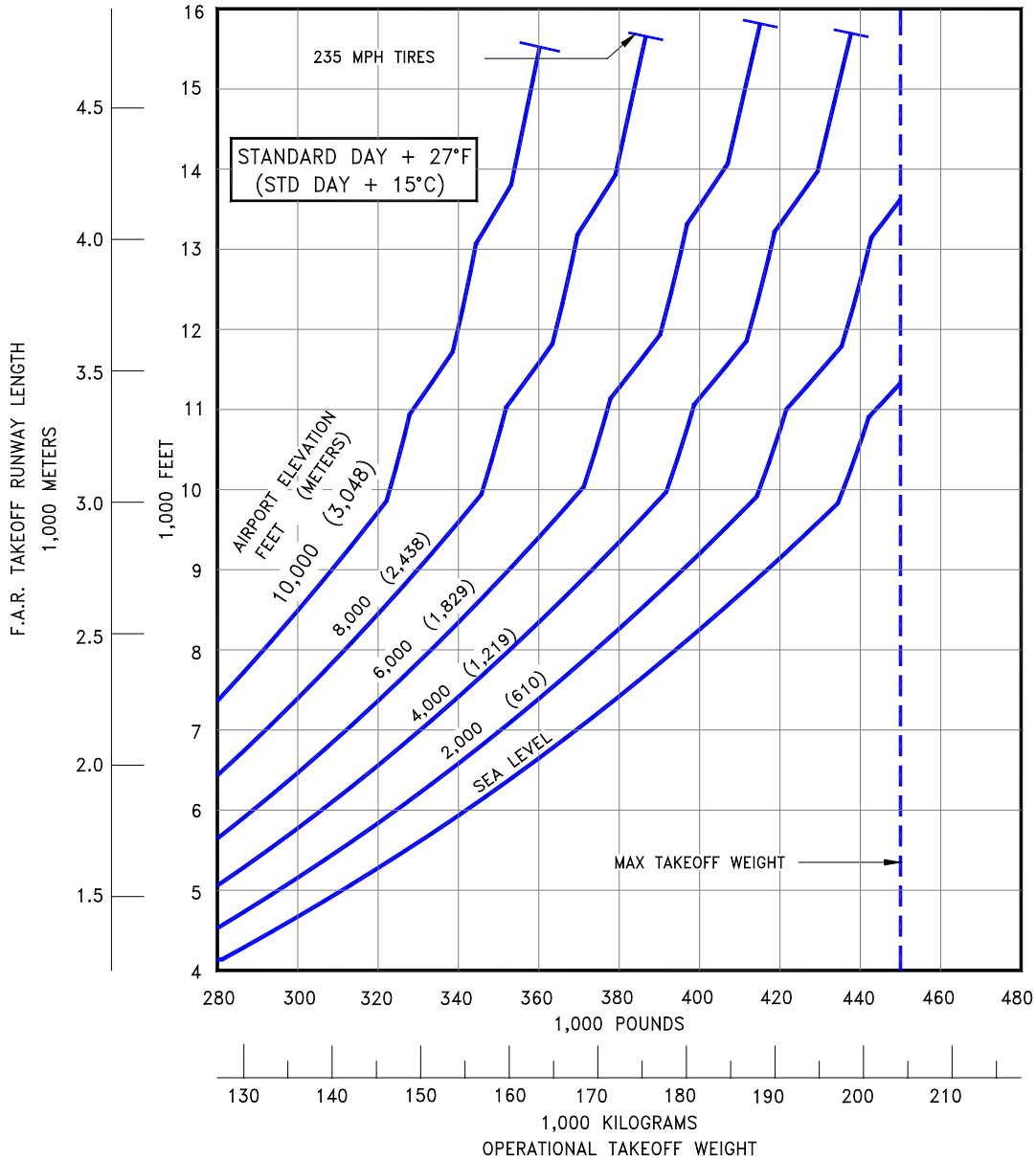

3.3.33 FAA/EASA Takeoff Runway Length Requirements - Standard Day, Dry Runway Surface: Model 767-400ER (PW4062 Engines)

NOTES:

- PW 4062 ENGINES
- NO ENGINE AIRBLEED FOR AIR CONDITIONING
- ZERO WIND, ZERO RUNWAY GRADIENT
- DRY RUNWAY SURFACE
- CONSULT USING AIRLINE FOR SPECIFIC OPERATING PROCEDURE PRIOR TO FACILITY DESIGN

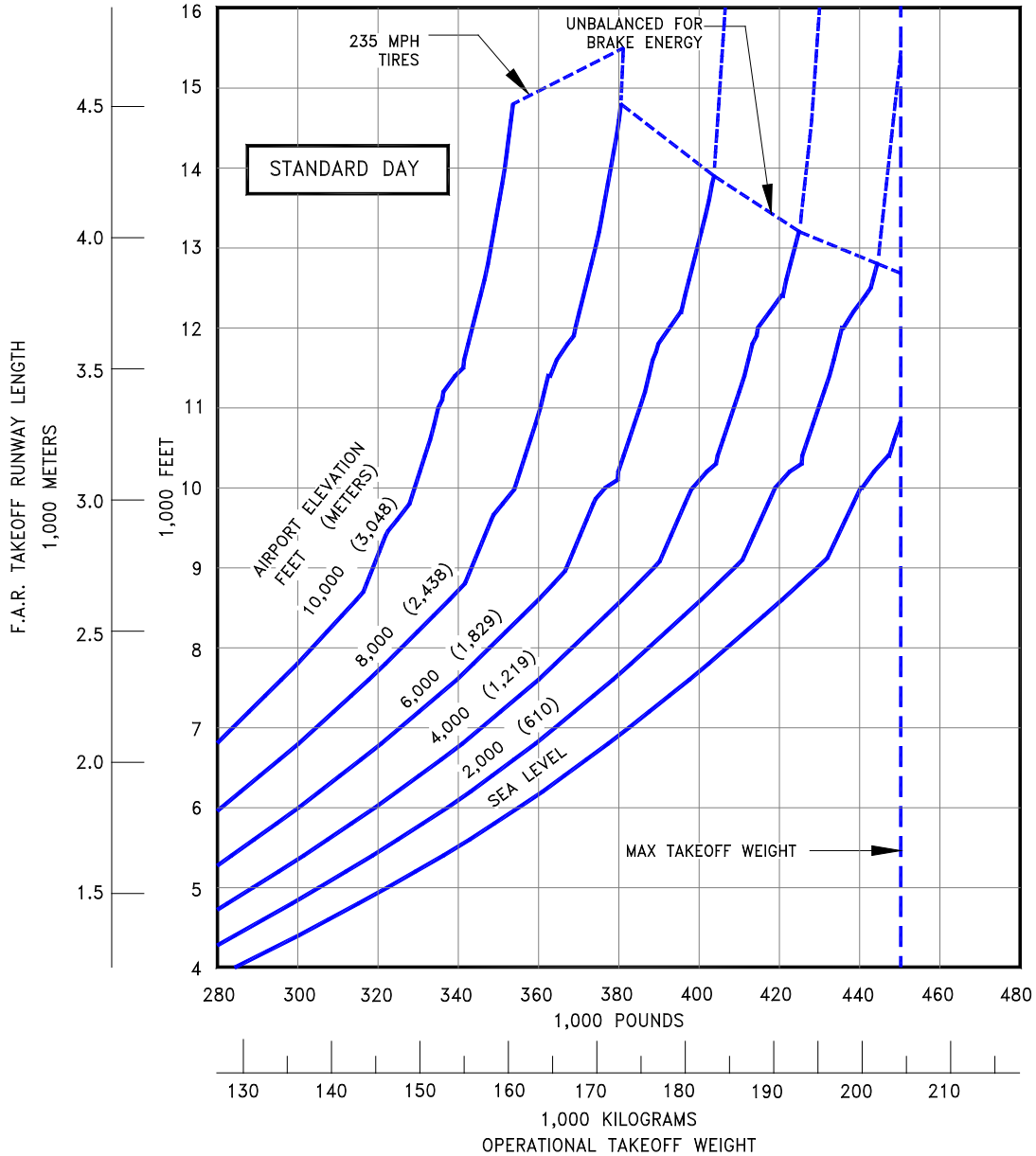

3.3.34 FAA/EASA Takeoff Runway Length Requirements - Standard Day + 27°F (STD + 15°C), Dry Runway Surface: Model 767-400ER (PW4062 Engines)

NOTES:

- PW 4062 ENGINES
- NO ENGINE AIRBLEED FOR AIR CONDITIONING
- ZERO WIND, ZERO RUNWAY GRADIENT
- DRY RUNWAY SURFACE
- CONSULT USING AIRLINE FOR SPECIFIC OPERATING PROCEDURE PRIOR TO FACILITY DESIGN

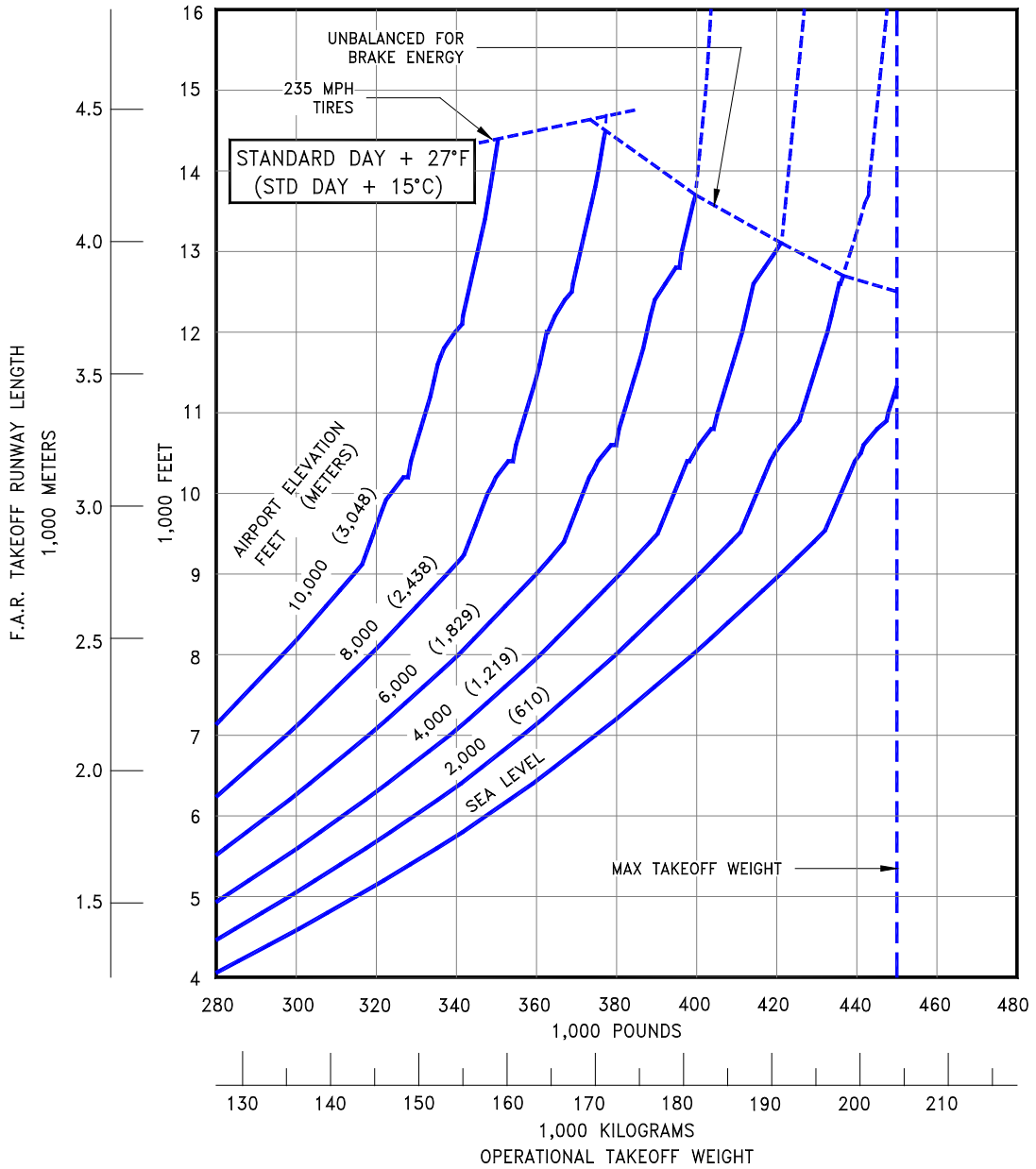

3.3.35 FAA/EASA Takeoff Runway Length Requirements - Standard Day, Wet Smooth Runway Surface: Model 767-400ER (PW4062 Engines)

NOTES:

- PW4062 ENGINES
- NO ENGINE AIRBLEED FOR AIR CONDITIONING
- ZERO WIND, ZERO RUNWAY GRADIENT
- WET SMOOTH RUNWAY SURFACE
- CONSULT USING AIRLINE FOR SPECIFIC OPERATING PROCEDURE PRIOR TO FACILITY DESIGN

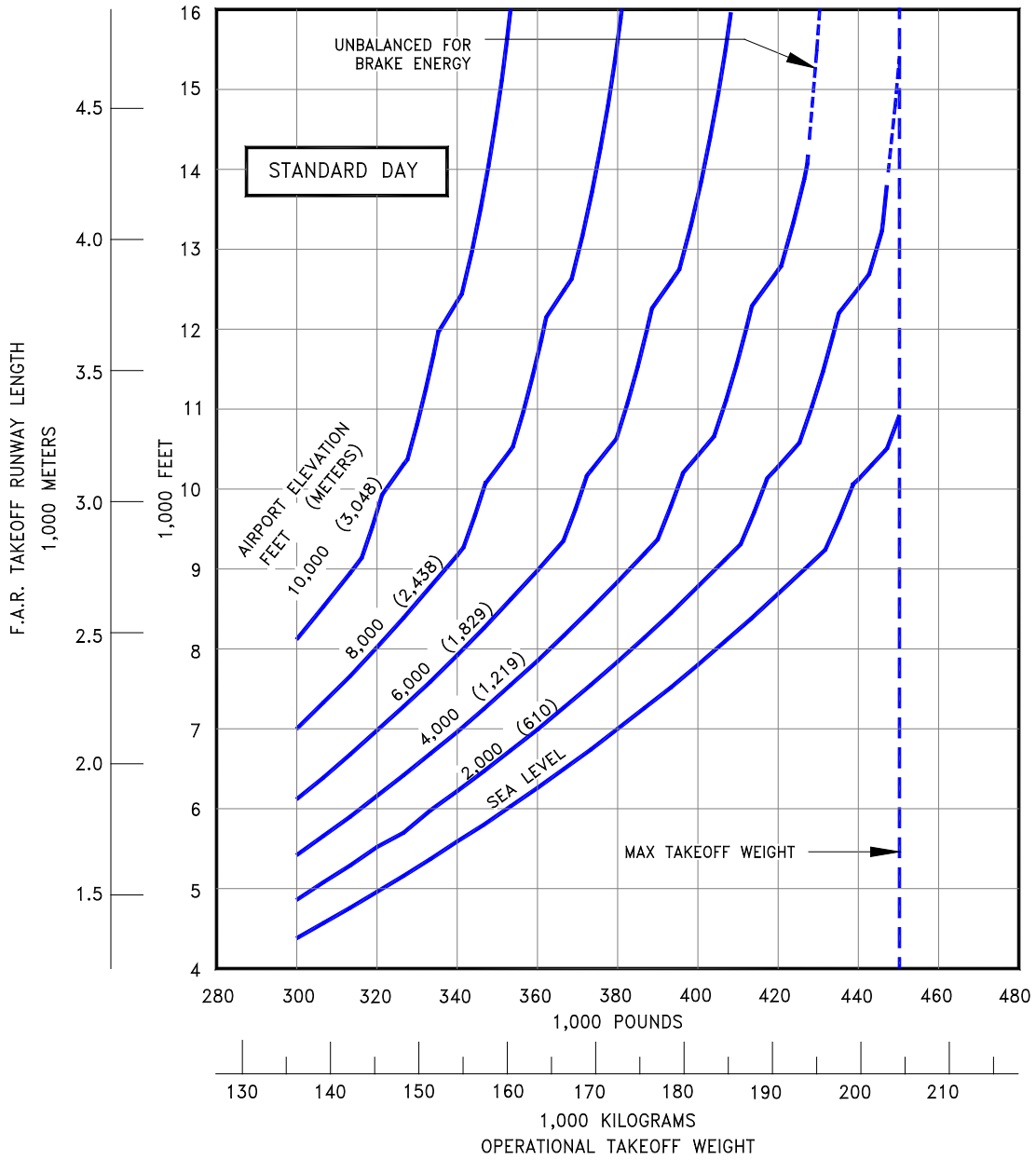

3.3.36 FAA/EASA Takeoff Runway Length Requirements - Standard Day + 27°F (STD + 15°C), Wet Smooth Runway Surface: Model 767-400ER (PW4062 Engines)

NOTES:

- PW 4062 ENGINES
- NO ENGINE AIRBLEED FOR AIR CONDITIONING
- ZERO WIND, ZERO RUNWAY GRADIENT
- WET SMOOTH RUNWAY SURFACE
- CONSULT USING AIRLINE FOR SPECIFIC OPERATING PROCEDURE PRIOR TO FACILITY DESIGN

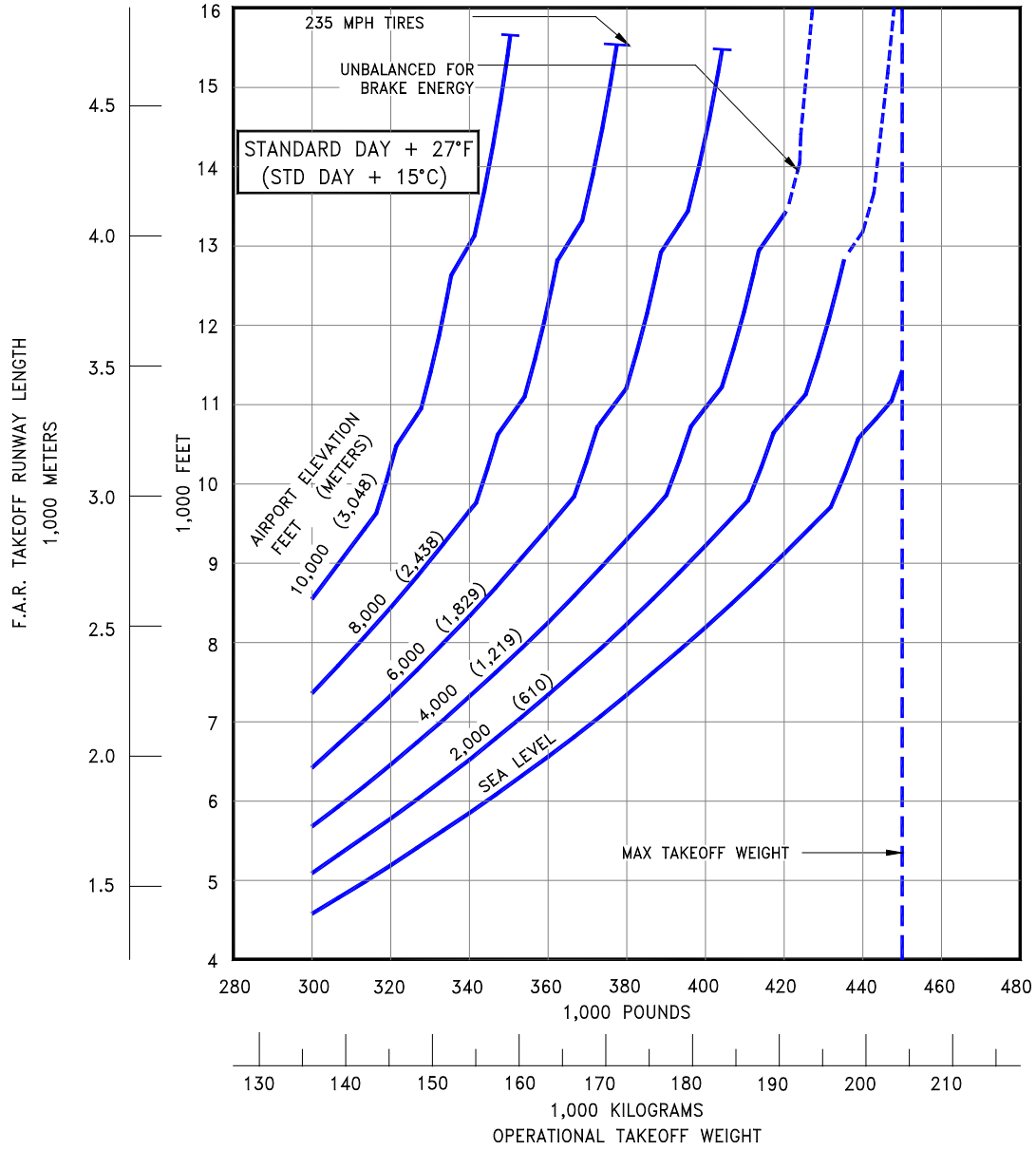

3.4 FAA/EASA LANDING RUNWAY LENGTH REQUIREMENTS

3.4.1 FAA Landing Runway Length Requirements – Flaps 25: Model 767-200, -200ER

NOTES:

- NO REVERSE THRUST
- ANTI-SKID ON
- AUTO SPEED BRAKES
- ZERO WIND, ZERO RUNWAY SLOPE
- CONSULT USING AIRLINE FOR SPECIFIC OPERATING PROCEDURE PRIOR TO FACILITY DESIGN

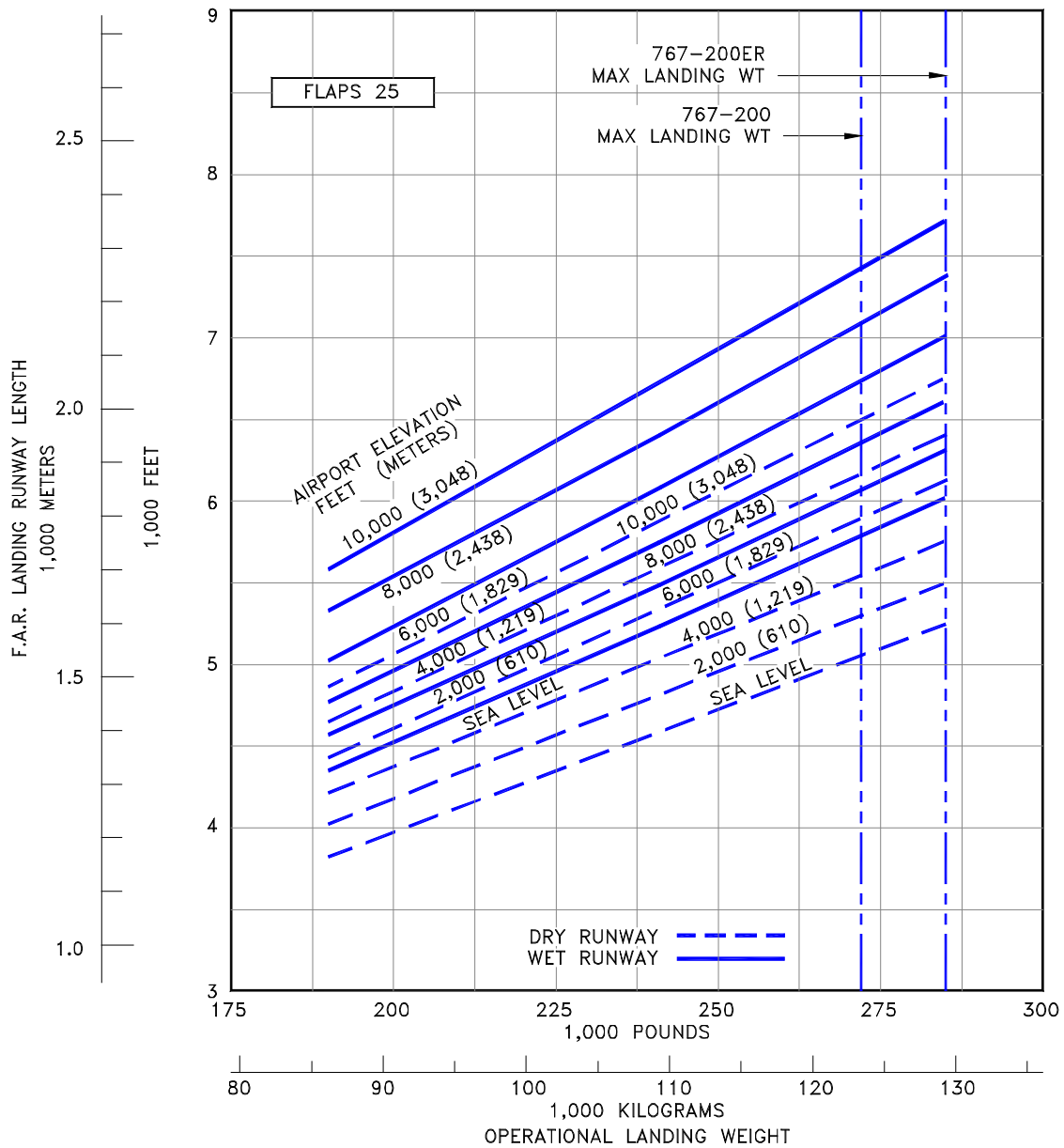

3.4.2 FAA/EASA Landing Runway Length Requirements – Flaps 30: Model 767-200, -200ER

NOTES:

- NO REVERSE THRUST
- ANTI-SKID ON
- AUTO SPEED BRAKES
- ZERO WIND, ZERO RUNWAY SLOPE
- CONSULT USING AIRLINE FOR SPECIFIC OPERATING PROCEDURE PRIOR TO FACILITY DESIGN

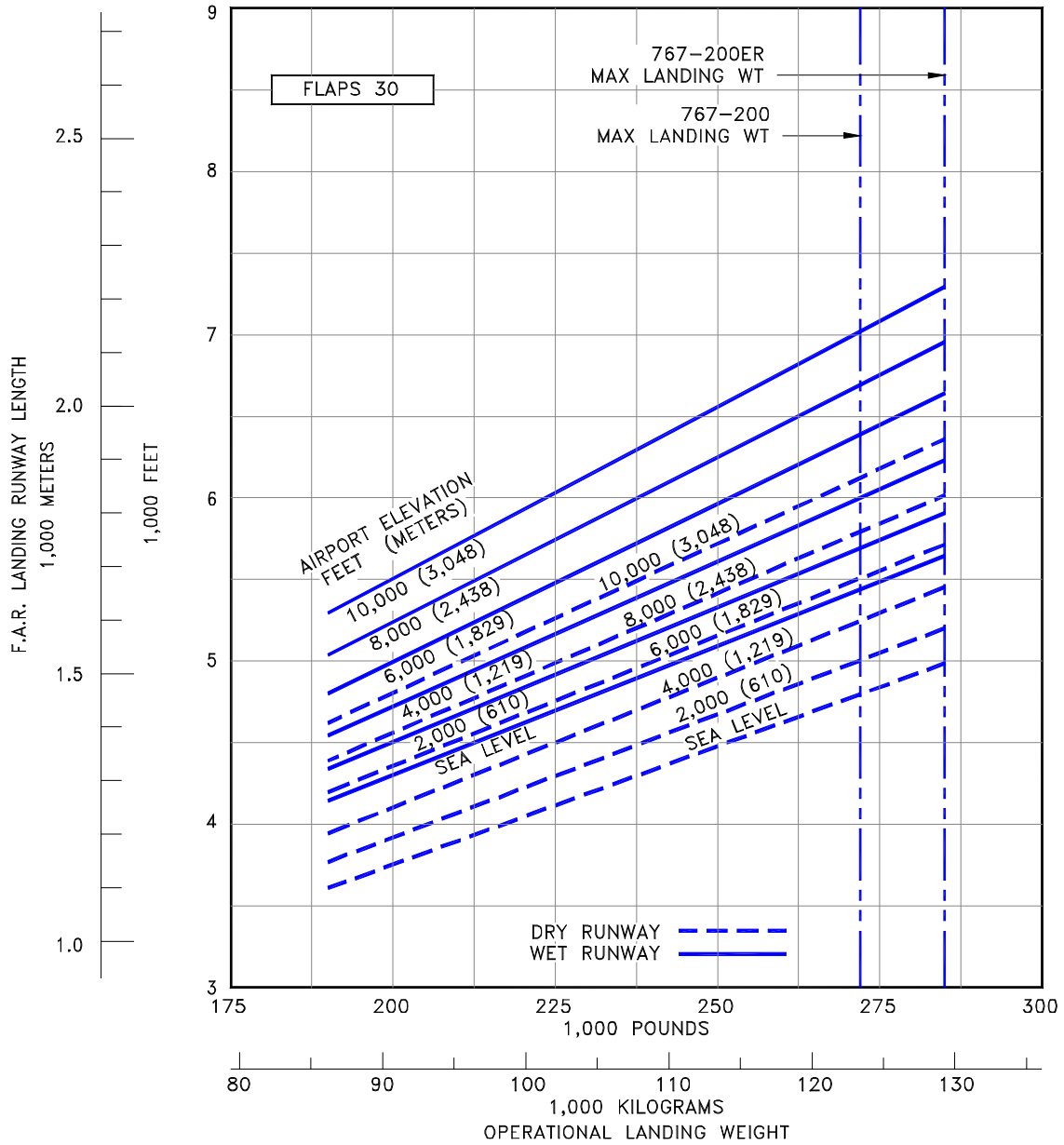

D6-58328

REV I

July 2021

3-49

3.4.3 FAA/EASA Landing Runway Length Requirements – Flaps 25: Model 767-300

NOTES:

- NO REVERSE THRUST
- ANTI-SKID ON
- AUTO SPEED BRAKES
- ZERO WIND, ZERO RUNWAY SLOPE
- CONSULT USING AIRLINE FOR SPECIFIC OPERATING PROCEDURE PRIOR TO FACILITY DESIGN

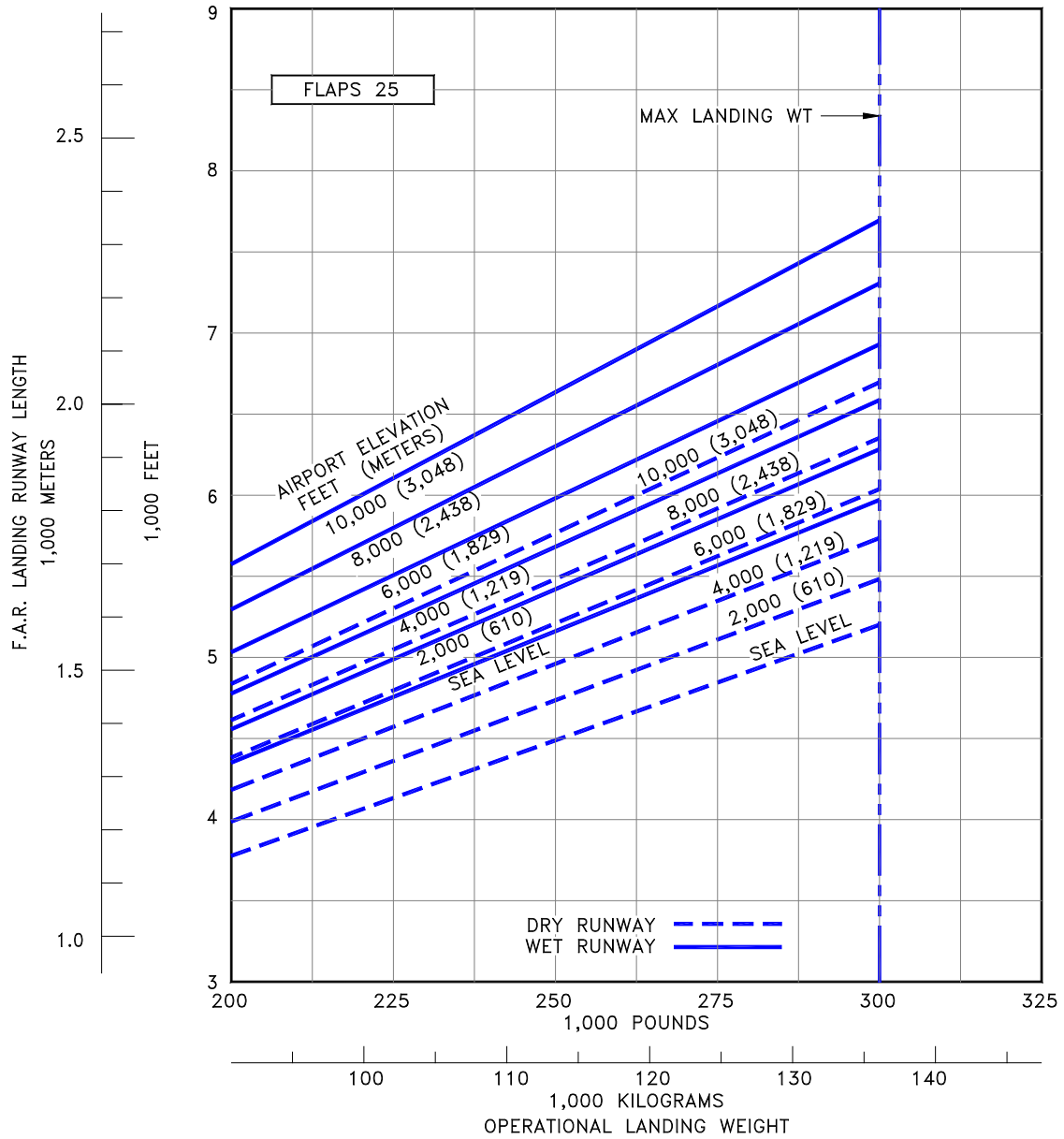

3.4.4 FAA/EASA Landing Runway Length Requirements – Flaps 30: Model 767-300

NOTES:

- NO REVERSE THRUST
- ANTI-SKID ON
- AUTO SPEED BRAKES
- ZERO WIND, ZERO RUNWAY SLOPE
- CONSULT USING AIRLINE FOR SPECIFIC OPERATING PROCEDURE PRIOR TO FACILITY DESIGN

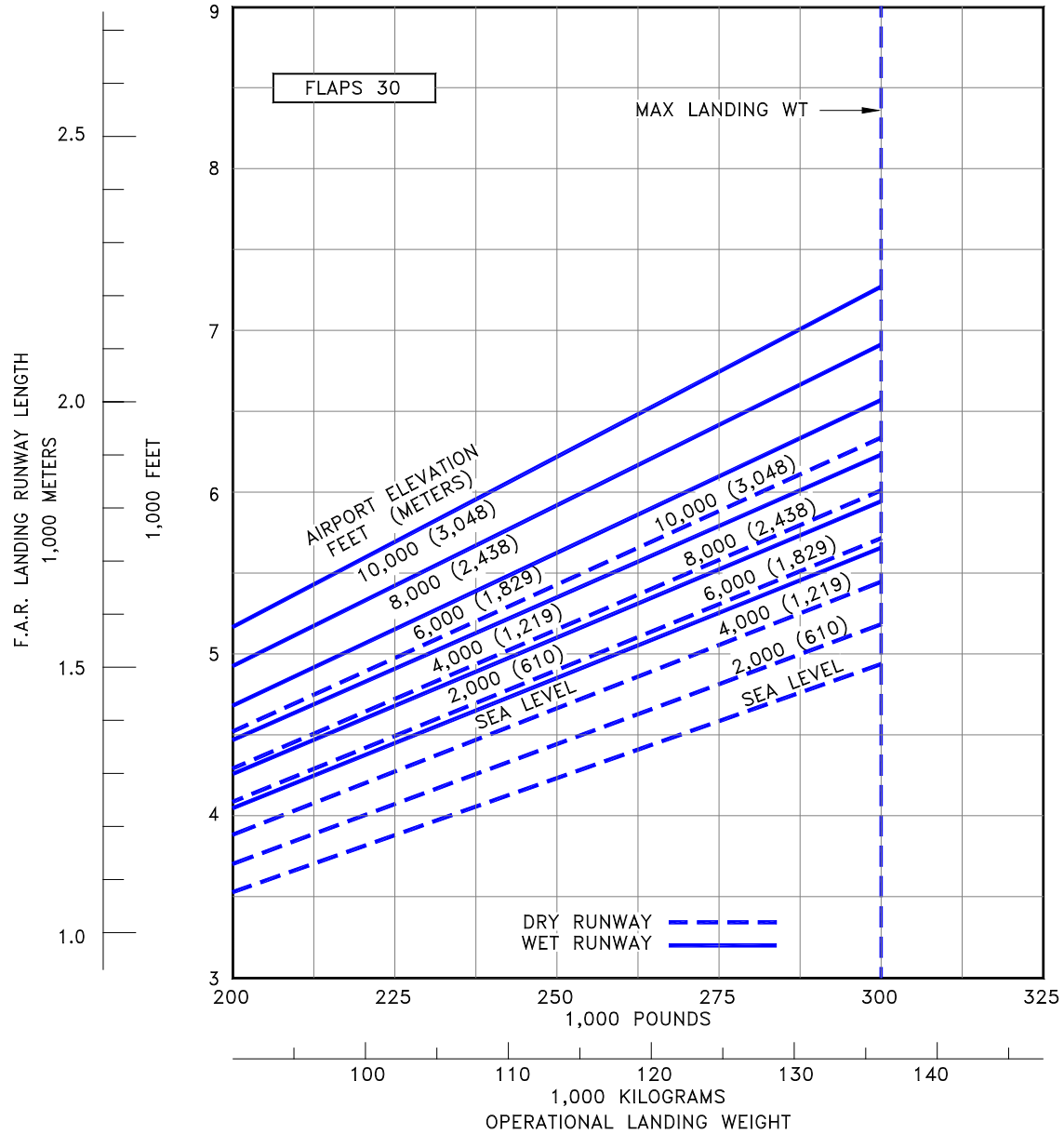

3.4.5 FAA/EASA Landing Runway Length Requirements – Flaps 25: Model 767-300ER

NOTES:

- NO REVERSE THRUST
- ANTI-SKID ON
- AUTO SPEED BRAKES
- ZERO WIND, ZERO RUNWAY SLOPE
- CONSULT USING AIRLINE FOR SPECIFIC OPERATING PROCEDURE PRIOR TO FACILITY DESIGN

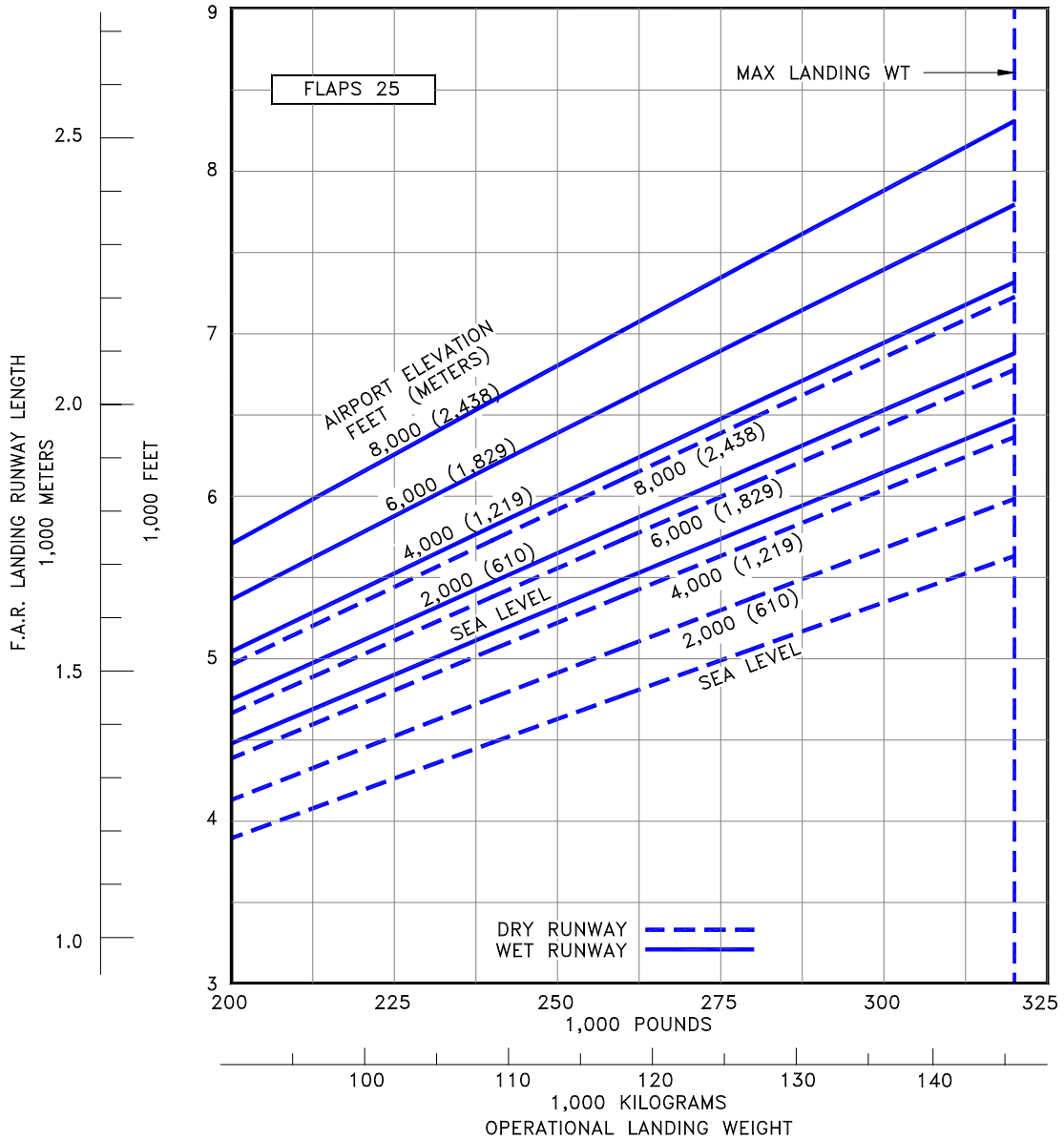

3.4.6 FAA/EASA Landing Runway Length Requirements – Flaps 30: Model 767-300ER

NOTES:

- NO REVERSE THRUST
- ANTI-SKID ON
- AUTO SPEED BRAKES
- ZERO WIND, ZERO RUNWAY SLOPE
- CONSULT USING AIRLINE FOR SPECIFIC OPERATING PROCEDURE PRIOR TO FACILITY DESIGN

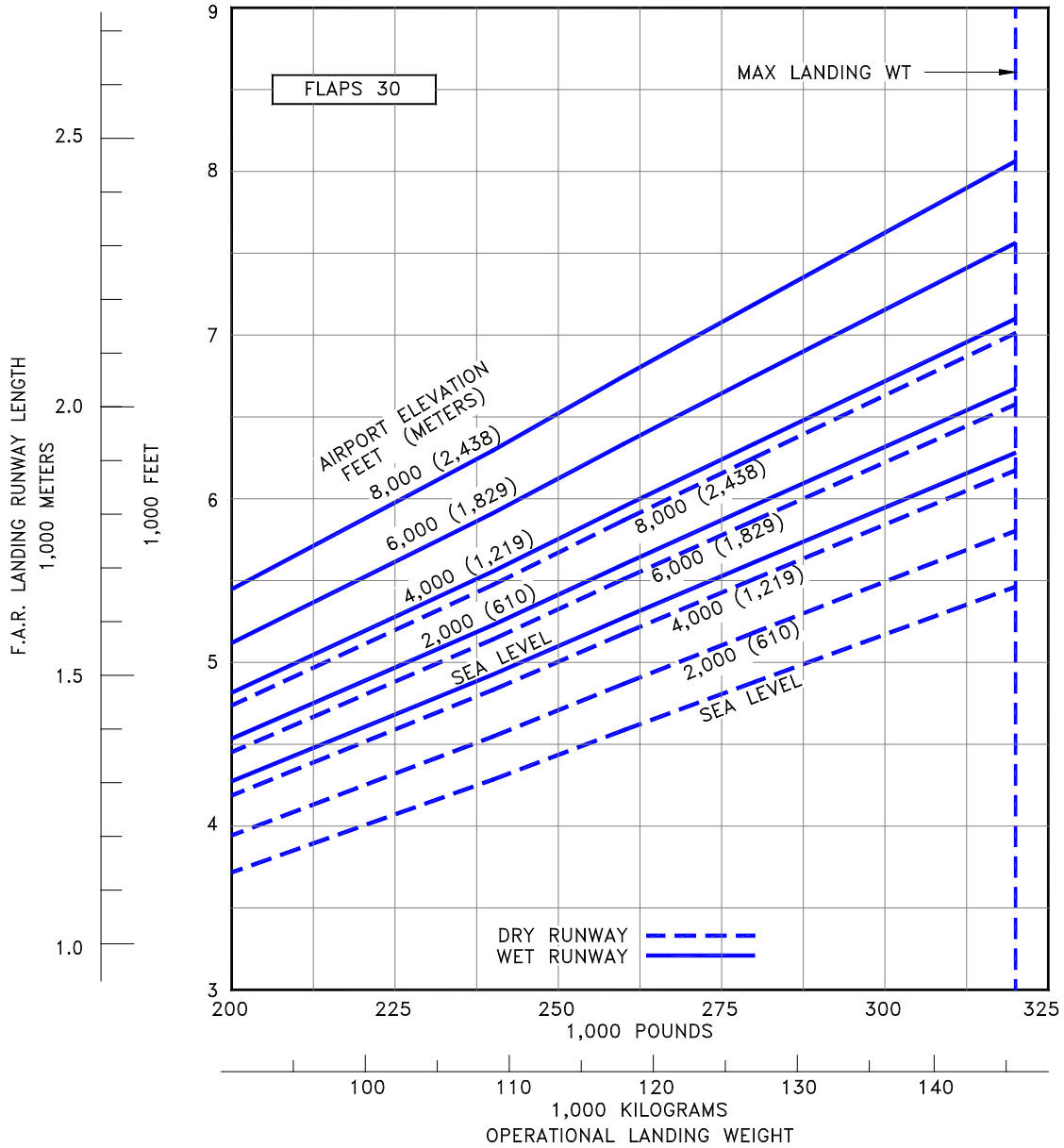

3.4.7 FAA/EASA Landing Runway Length Requirements – Flaps 25: Model 767-300 Freighter

NOTES:

- NO REVERSE THRUST
- ANTI-SKID ON
- AUTO SPEED BRAKES
- ZERO WIND, ZERO RUNWAY SLOPE
- CONSULT USING AIRLINE FOR SPECIFIC OPERATING PROCEDURE PRIOR TO FACILITY DESIGN

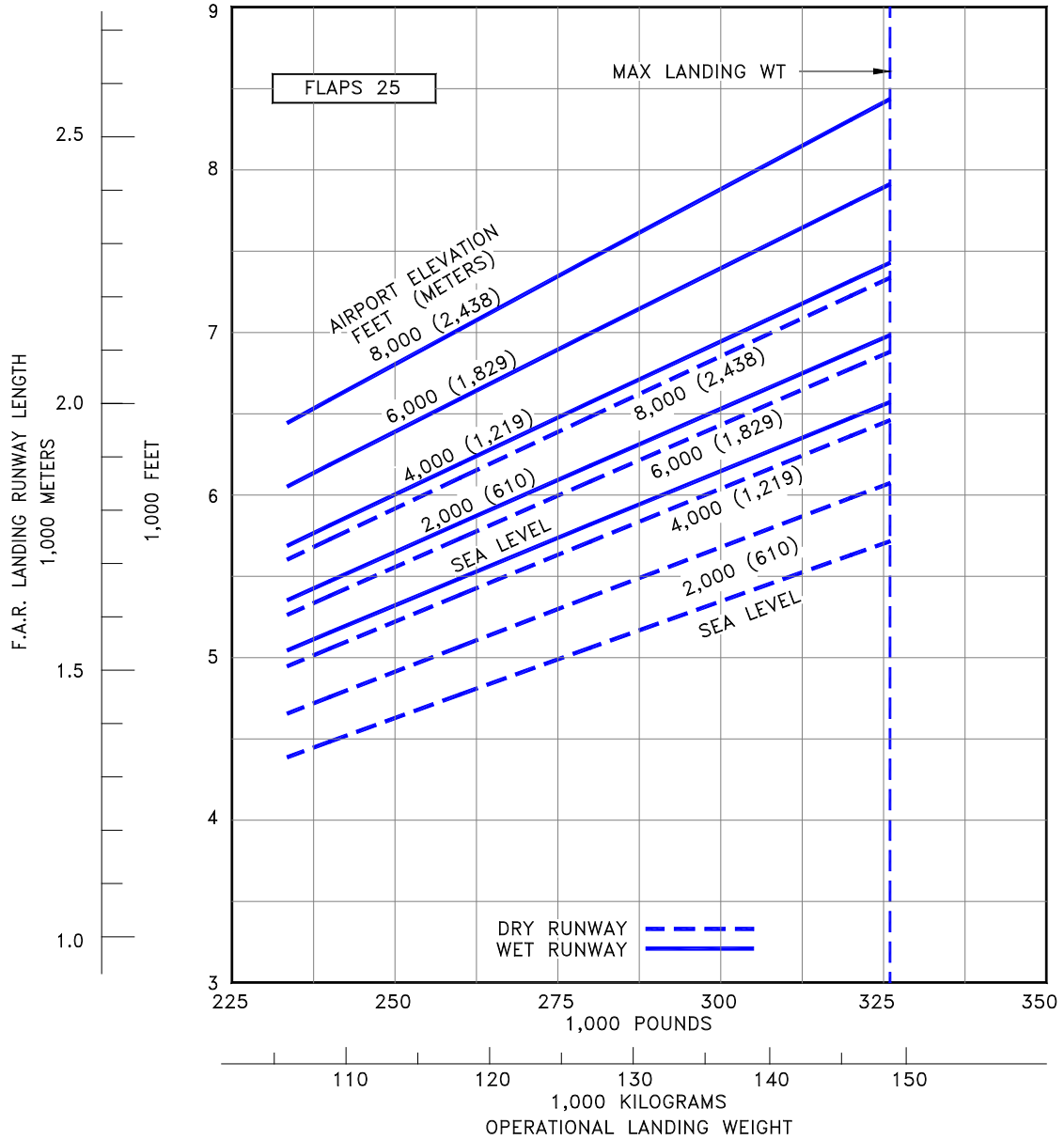

3.4.8 FAA/EASA Landing Runway Length Requirements – Flaps 30: Model 767-300 Freighter

NOTES:

- NO REVERSE THRUST
- ANTI-SKID ON
- AUTO SPEED BRAKES
- ZERO WIND, ZERO RUNWAY SLOPE
- CONSULT USING AIRLINE FOR SPECIFIC OPERATING PROCEDURE PRIOR TO FACILITY DESIGN

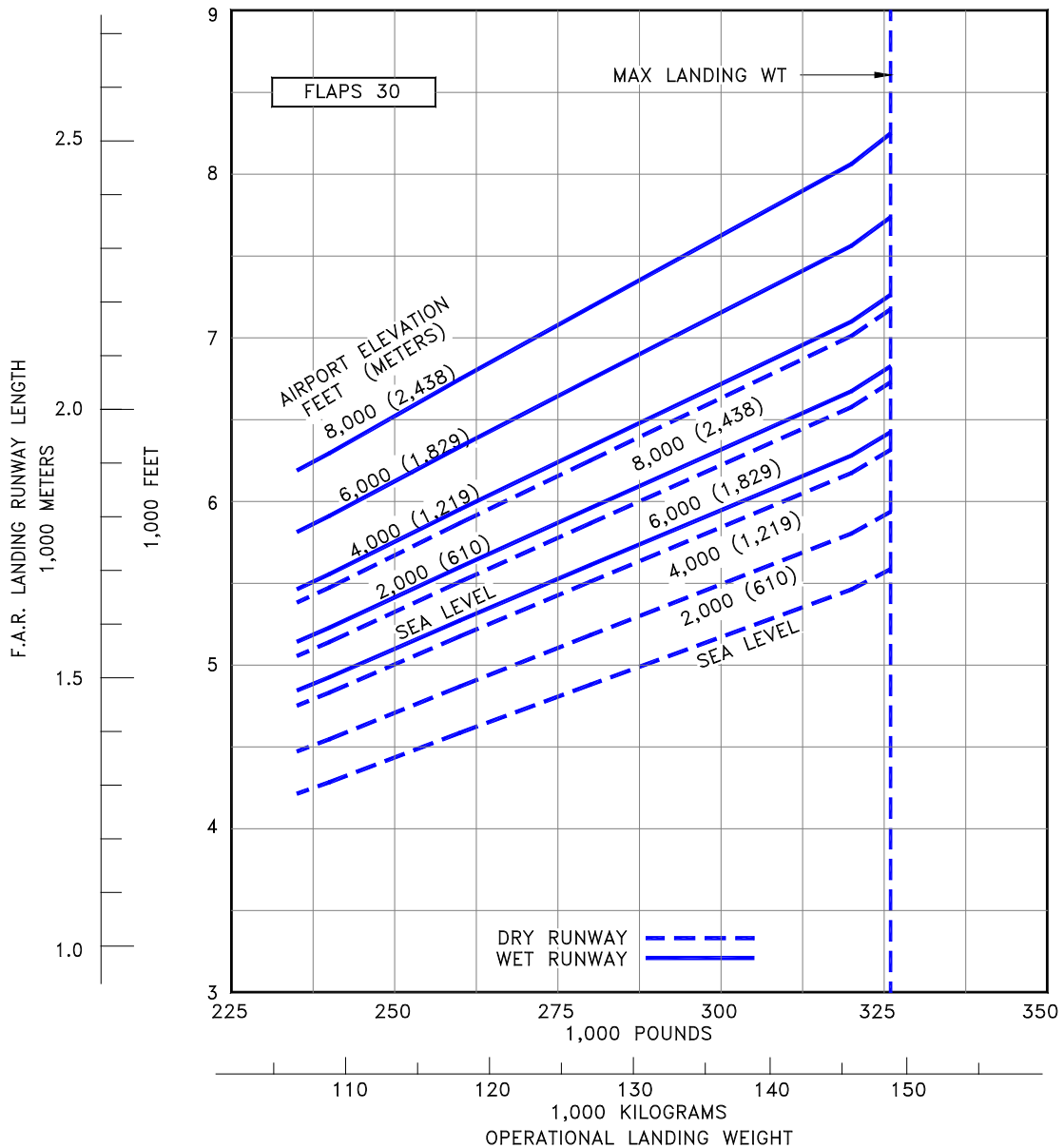

3.4.9 FAA/EASA Landing Runway Length Requirements – Flaps 25: Model 767-400ER

NOTES:

- STANDARD DAY
- NO REVERSE THRUST
- ANTI-SKID OPERATIVE
- AUTO SPEED BRAKES
- ZERO WIND
- ZERO SLOPE
- CONSULT USING AIRLINE FOR SPECIFIC OPERATING PROCEDURE PRIOR TO FACILITY DESIGN

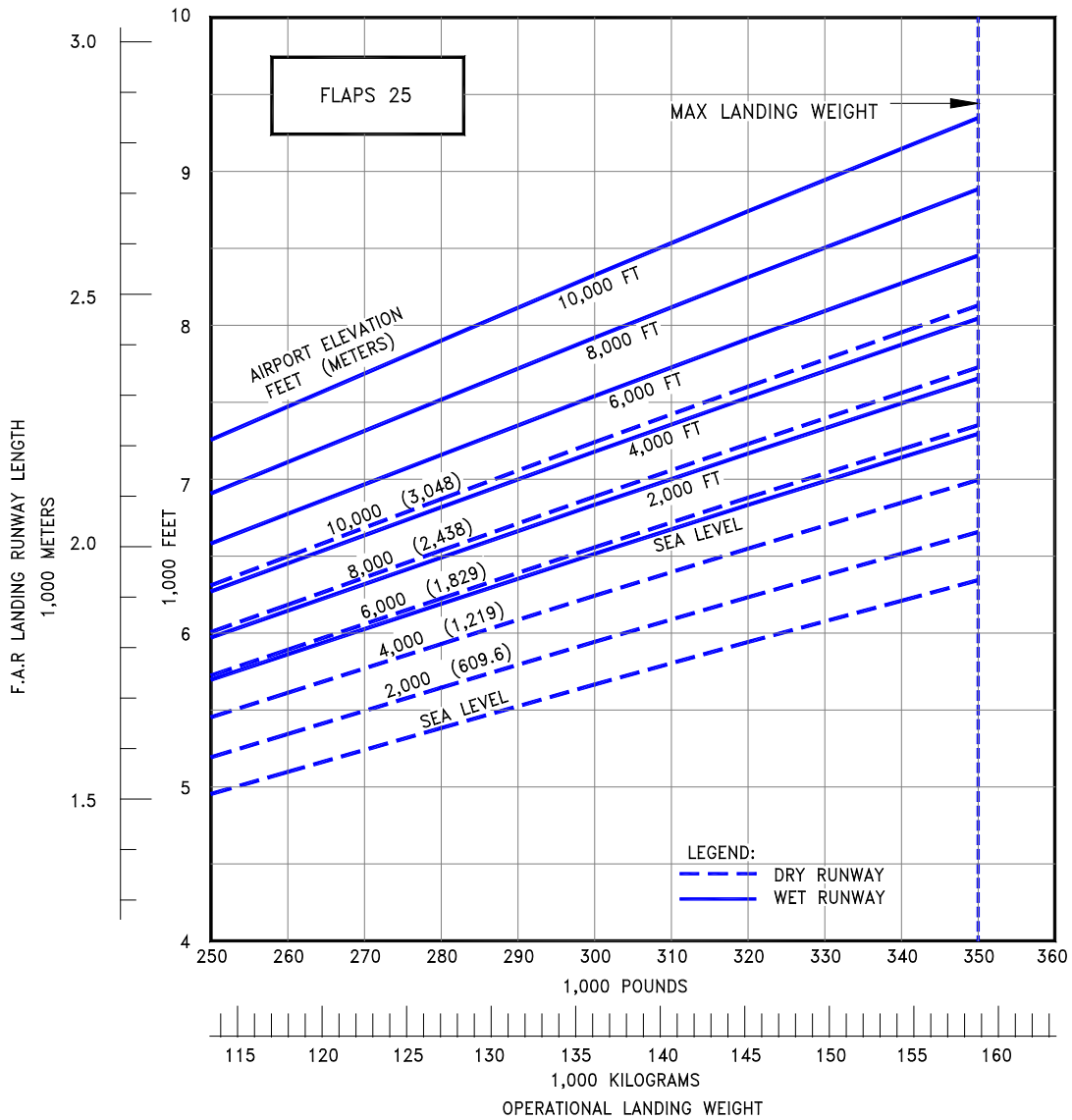

D6-58328

3.4.10 FAA/EASA Landing Runway Length Requirements – Flaps 30: Model 767-400ER

NOTES:

- STANDARD DAY
- NO REVERSE THRUST
- ANTI-SKID OPERATIVE
- AUTO SPEED BRAKES
- ZERO WIND
- ZERO SLOPE
- CONSULT USING AIRLINE FOR SPECIFIC OPERATING PROCEDURE PRIOR TO FACILITY DESIGN

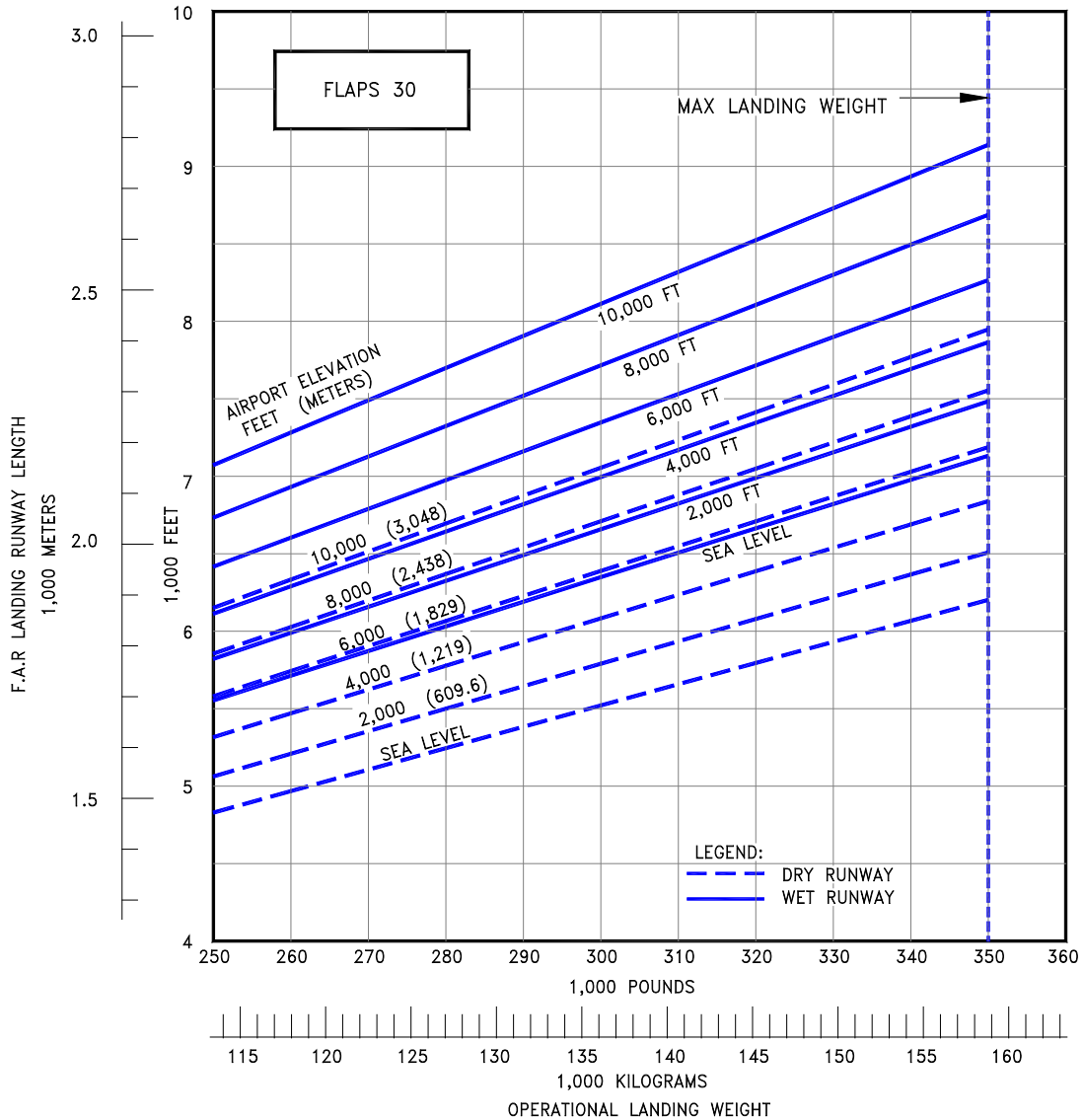

4.0 GROUND MANEUVERING

4.1 GENERAL INFORMATION

This section provides airplane turning capability and maneuvering characteristics.

For ease of presentation, these data have been determined from the theoretical limits imposed by the geometry of the aircraft, and where noted, provide for a normal allowance for tire slippage. As such, they reflect the turning capability of the aircraft in favorable operating circumstances. These data should be used only as guidelines for the method of determination of such parameters and for the maneuvering characteristics of this aircraft.

In the ground operating mode, varying airline practices may demand that more conservative turning procedures be adopted to avoid excessive tire wear and reduce possible maintenance problems. Airline operating procedures will vary in the level of performance over a wide range of operating circumstances throughout the world. Variations from standard aircraft operating patterns may be necessary to satisfy physical constraints within the maneuvering area, such as adverse grades, limited area, or high risk of jet blast damage. For these reasons, ground maneuvering requirements should be coordinated with the using airlines prior to layout planning.

Section 4.2 presents turning radii for various nose gear steering angles. Radii for the main and nose gears are measured from the turn center to the outside of the tire.

Section 4.3 provides data on minimum width of pavement required for 180° turn.

Section 4.4 shows the pilot's visibility from the cockpit and the limits of ambinocular vision through the windows. Ambinocular vision is defined as the total field of vision seen simultaneously by both eyes.

Section 4.5 shows approximate wheel paths for various runway and taxiway turn scenarios. The pavement fillet geometries are based on the FAA's Advisory Circular (AC) 150/5300-13 (thru change 16). They represent typical fillet geometries built at many airports worldwide. ICAO and other civil aviation authorities publish many different fillet design methods. Prior to determining the size of fillets, airports are advised to check with the airlines regarding the operating procedures and aircraft types they expect to use at the airport. Further, given the cost of modifying fillets and the operational impact to ground movement and air traffic during construction, airports may want to design critical fillets for larger aircraft types to minimize future operational impacts.

Section 4.6 illustrates a typical runway holding bay configuration.

4.2 TURNING RADII

4.2.1 Turning Radii – No Slip Angle: Model 767-200, -200ER

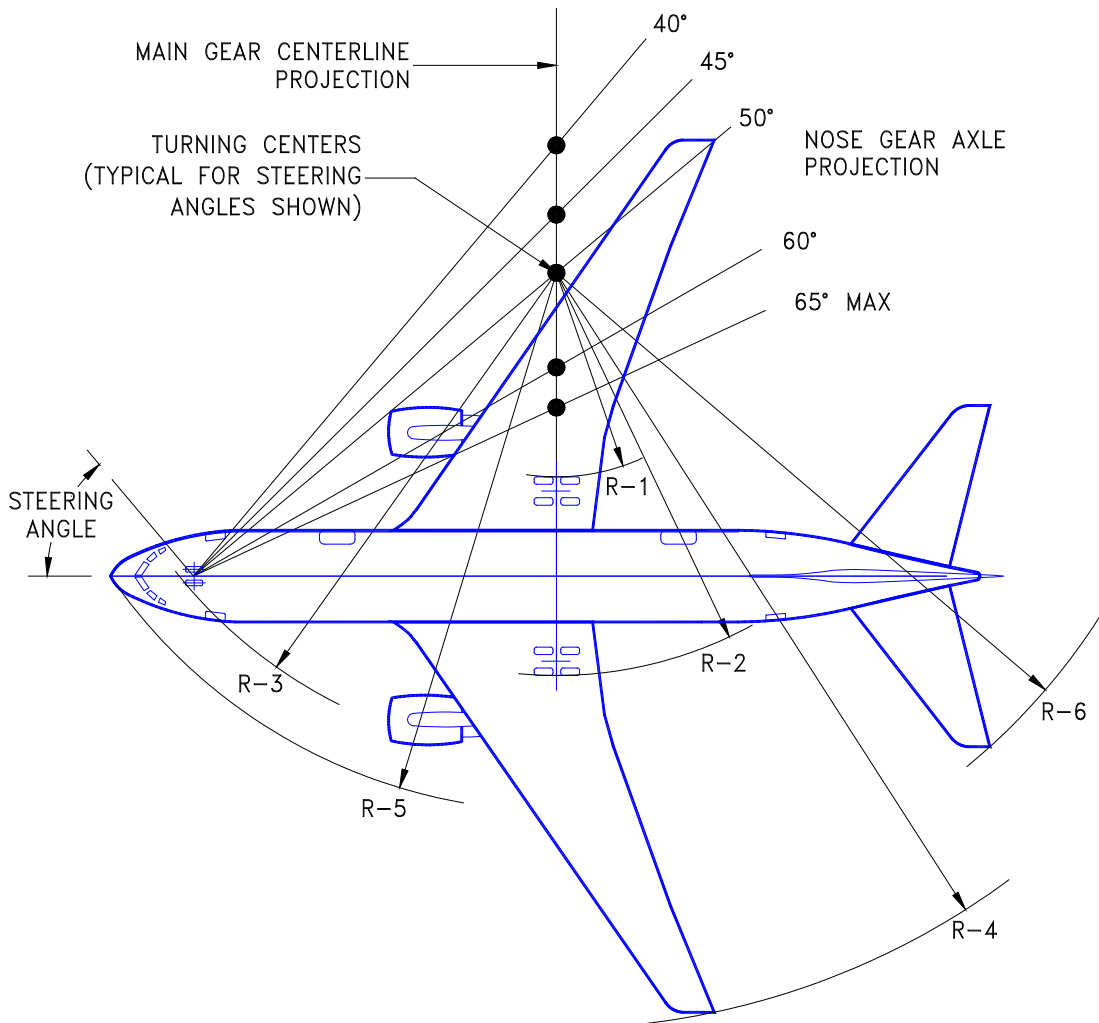

NOTES: * ACTUAL OPERATING TURNING RADII MAY BE GREATER THAN SHOWN.
 * CONSULT WITH AIRLINE FOR SPECIFIC OPERATING PROCEDURE

STEERING ANGLE (DEG)	R1 INNER GEAR		R2 OUTER GEAR		R3 NOSE GEAR		R4 WINGTIP		R5 NOSE		R6 TAIL	
	FT	M	FT	M	FT	M	FT	M	FT	M	FT	M
30	94.0	28.7	129.7	39.5	130.8	39.9	192.1	58.5	137.3	41.8	161.8	49.3
35	74.4	22.7	110.1	33.6	114.3	34.8	172.7	52.6	121.8	37.1	144.8	44.1
40	59.1	18.0	94.8	28.9	102.1	31.1	157.6	48.0	110.7	33.7	132.1	40.3
45	46.7	14.2	82.4	25.1	93.0	28.3	145.4	44.3	102.4	31.2	122.2	37.3
50	36.4	11.1	72.1	22.0	86.0	26.2	135.2	41.2	96.2	29.3	114.3	34.8
55	27.4	8.3	63.1	19.2	80.5	24.5	126.5	38.6	91.5	27.9	107.8	32.9
60	19.4	5.9	55.1	16.8	76.2	23.2	118.7	36.2	87.8	26.8	102.4	31.2
65 (MAX)	12.3	3.7	48.0	14.6	72.9	22.2	111.8	34.1	85.0	25.9	97.8	29.8

D6-58328

4.2.2 Turning Radii – No Slip Angle: Model 767-300, -300ER, -300 Freighter

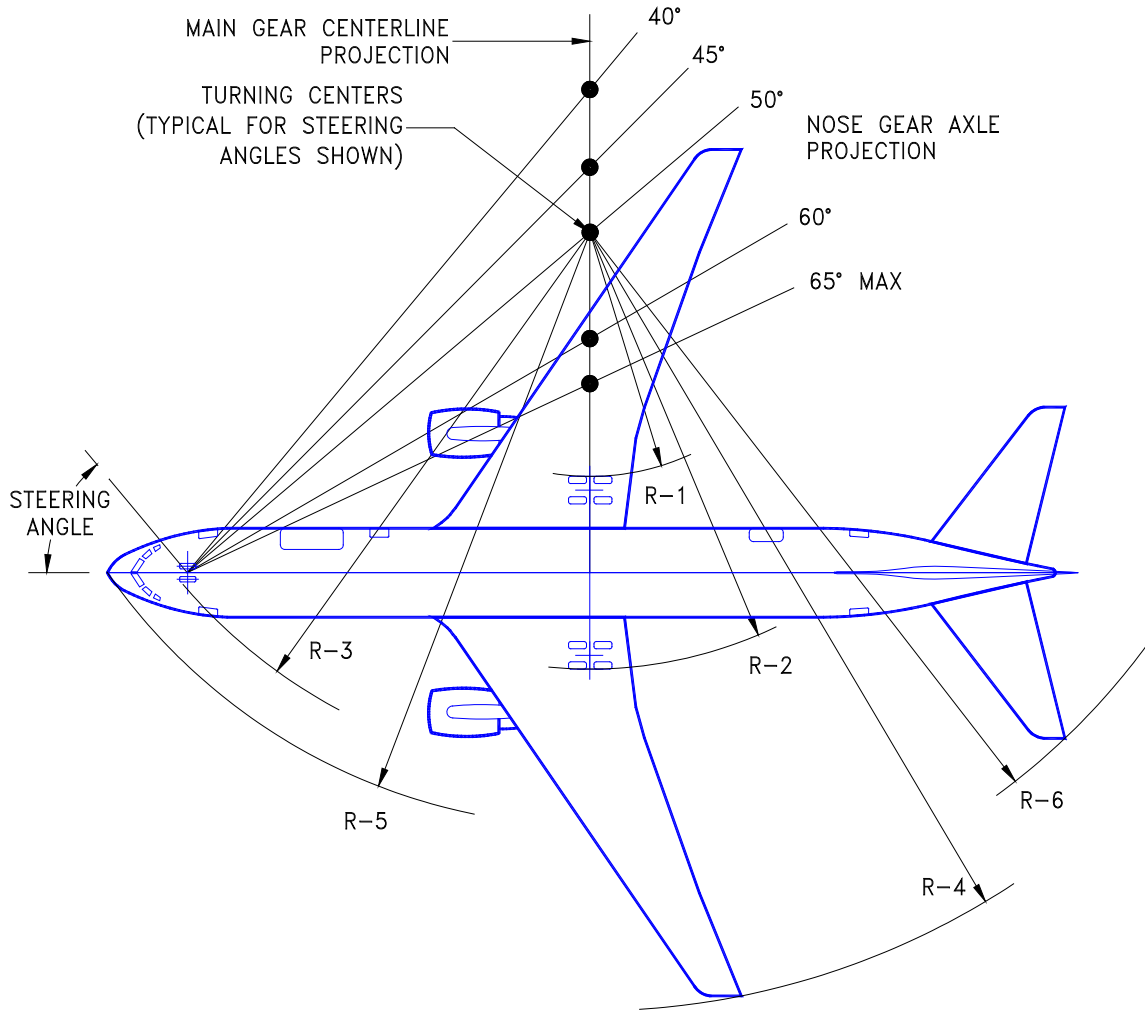

NOTES: * ACTUAL OPERATING TURNING RADII MAY BE GREATER THAN SHOWN.
* CONSULT WITH AIRLINE FOR SPECIFIC OPERATING PROCEDURE

STEERING ANGLE (DEG)	R1 INNER GEAR		R2 OUTER GEAR		R3 NOSE GEAR		R4 WINGTIP		R5 NOSE		R6 TAIL	
	FT	M	FT	M	FT	M	FT	M	FT	M	FT	M
30	111.5	34.0	147.3	44.9	151.0	46.0	209.4	63.8	157.4	48.0	181.8	55.4
35	88.8	27.1	124.6	38.0	131.9	40.2	186.9	57.0	139.3	42.5	162.2	49.4
40	71.1	21.7	106.9	32.6	117.9	35.9	169.5	51.7	126.3	38.5	147.6	45.0
45	56.8	17.3	92.6	28.2	107.3	32.7	155.4	47.4	116.7	35.6	136.2	41.5
50	44.8	13.6	80.6	24.6	99.2	30.2	143.5	43.8	109.3	33.3	127.2	38.8
55	34.4	10.5	70.2	21.4	92.8	28.3	133.4	40.7	103.7	31.6	119.8	36.5
60	25.2	7.7	61.0	18.6	87.9	26.8	124.4	37.9	99.4	30.3	113.6	34.6
65 (MAX)	16.9	5.2	52.7	16.1	84.1	25.6	116.4	35.5	96.1	29.3	108.4	33.1

4.2.3 Turning Radii – No Slip Angle: Model 767-400ER

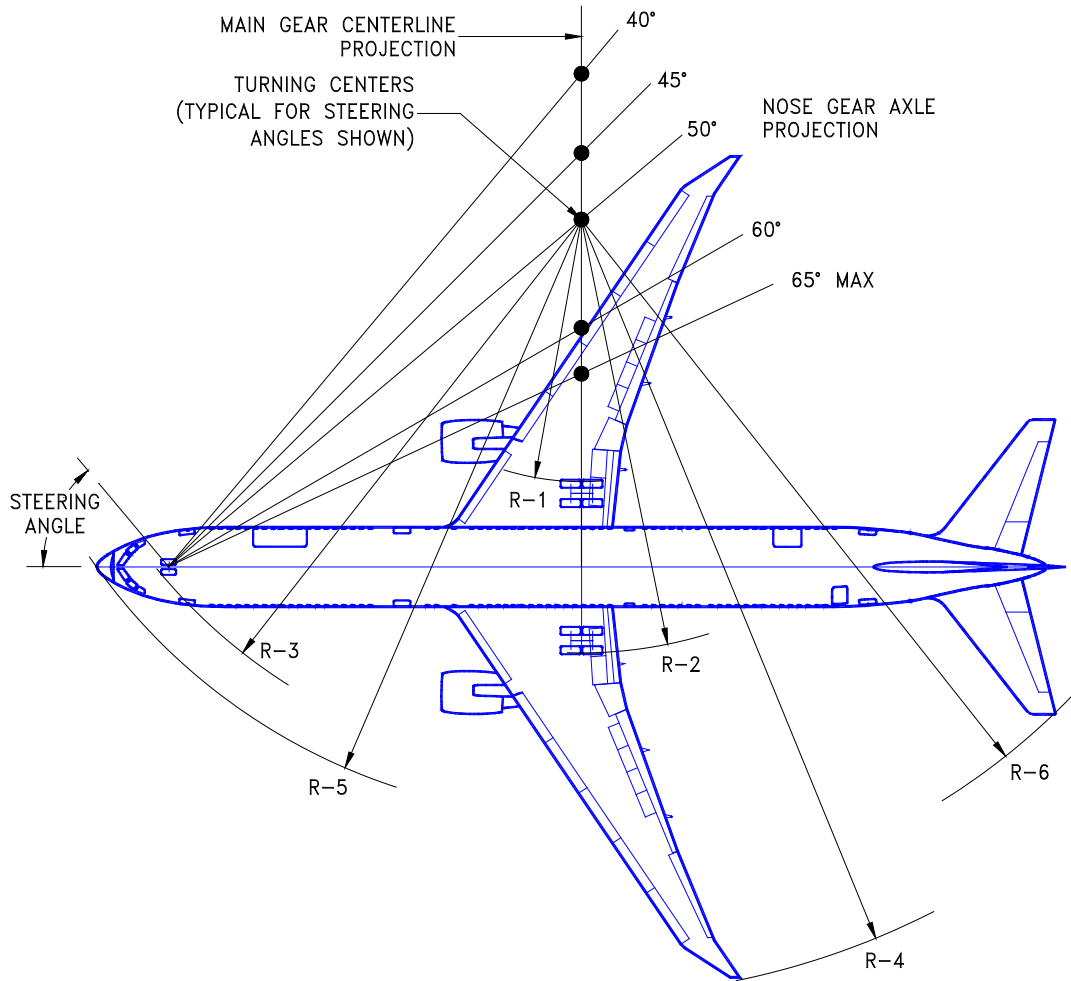

NOTES: * ACTUAL OPERATING TURNING RADII MAY BE GREATER THAN SHOWN.
 * CONSULT WITH AIRLINE FOR SPECIFIC OPERATING PROCEDURE

STEERING ANGLE (DEG)	R1 INNER GEAR		R2 OUTER GEAR		R3 NOSE GEAR		R4 WINGTIP		R5 NOSE		R6 TAIL	
	FT	M	FT	M	FT	M	FT	M	FT	M	FT	M
30	130.5	39.8	166.3	50.7	173.0	52.7	236.0	71.8	179.3	54.7	203.4	62.0
35	104.5	31.8	140.3	42.8	151.1	46.0	210.3	63.9	158.4	48.3	180.9	55.1
40	84.2	25.7	120.0	36.6	135.0	41.1	190.3	57.8	143.4	43.7	164.1	50.0
45	67.8	20.7	103.6	31.6	122.8	37.4	174.1	52.9	132.2	40.3	151.1	46.1
50	54.0	16.5	89.8	27.4	113.5	34.6	160.6	48.7	123.7	37.7	140.8	42.9
55	42.1	12.8	77.9	23.7	106.3	32.4	149.0	45.2	117.1	35.7	132.4	40.4
60	31.6	9.6	67.4	20.5	100.6	30.7	138.7	42.0	112.1	34.2	125.4	38.2
65 (MAX)	22.1	6.7	57.9	17.6	96.2	29.3	129.5	39.2	108.2	33.0	119.6	36.5

4.3 CLEARANCE RADII: MODEL 767-200, -200ER, -300, -300ER, -300 FREIGHTER -400ER

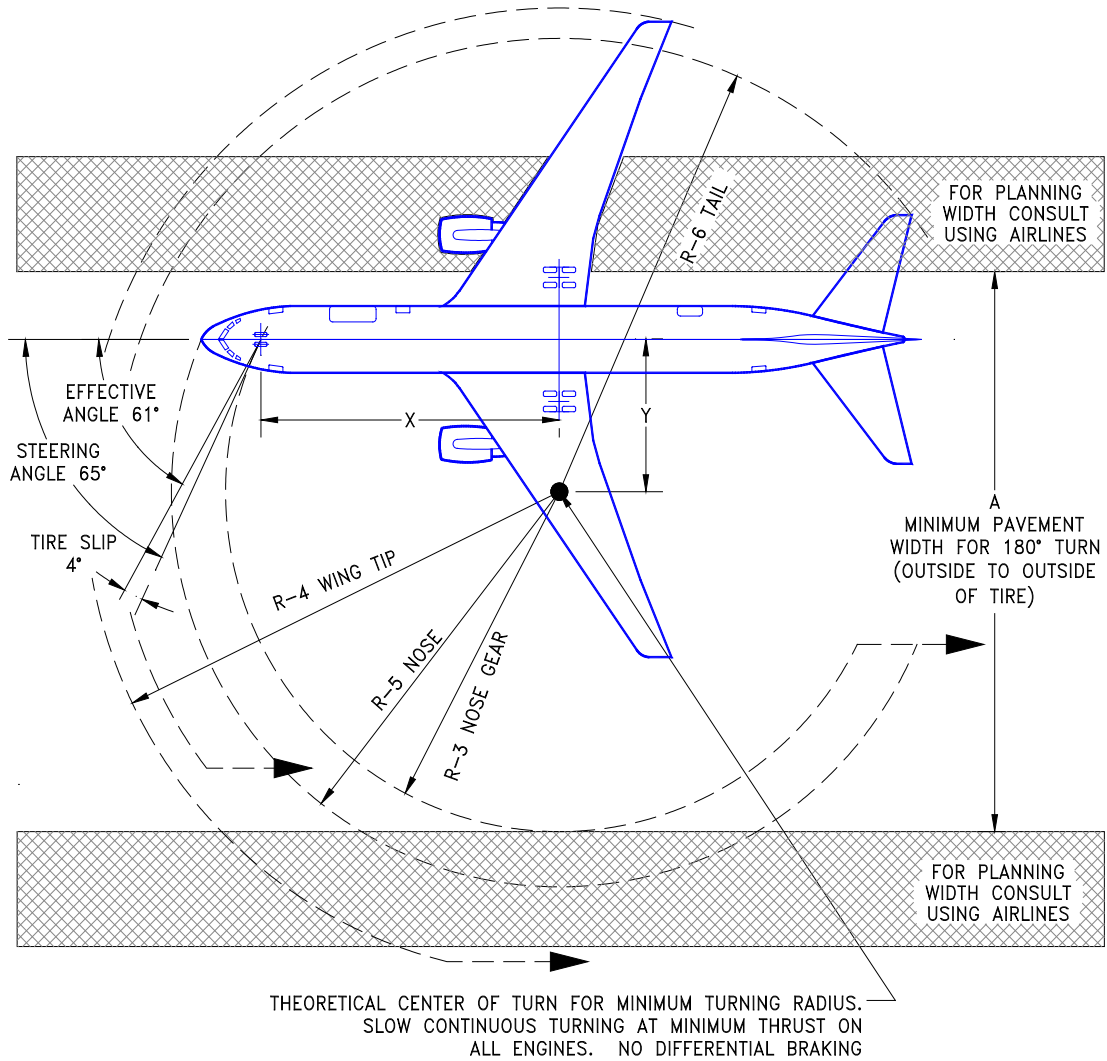

NOTES: * TIRE SLIP ANGLE APPROXIMATE FOR 61° STEERING ANGLE
 * CONSULT USING AIRLINE FOR SPECIFIC OPERATING PROCEDURE

AIRPLANE MODEL	EFFECTIVE TURNING ANGLE (DEG)	X		Y		A		R3		R4		R5		R6	
		FT	M	FT	M	FT	M	FT	M	FT	M	FT	M	FT	M
-200, -200ER	61	64.6	19.7	35.8	10.9	129.2	39.4	75.5	23.0	117.3	35.8	87.2	26.6	101.4	30.9
-300, -300ER, -300F	61	74.7	22.8	41.4	12.6	146.3	44.6	87.0	26.5	122.7	37.4	98.7	30.1	112.5	34.3
-400ER	61	85.7	26.1	47.5	14.5	165.1	50.3	99.6	30.4	136.8	41.7	111.3	33.9	124.2	37.9

4.4 VISIBILITY FROM COCKPIT IN STATIC POSITION: MODEL 767-200, -200ER, -300, -300ER, -300 FREIGHTER -400ER

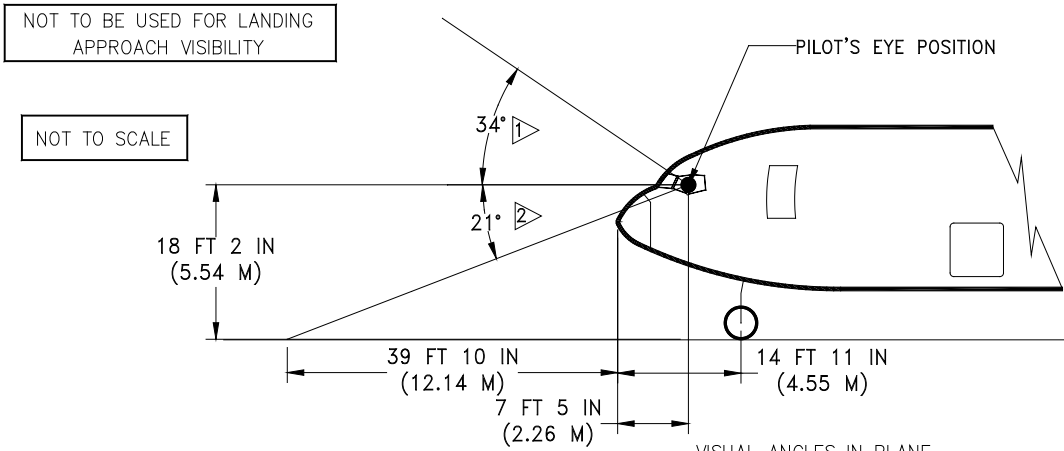

VISUAL ANGLES IN PLANE PARALLEL TO LONGITUDINAL AXIS THROUGH PILOT'S EYE POSITION

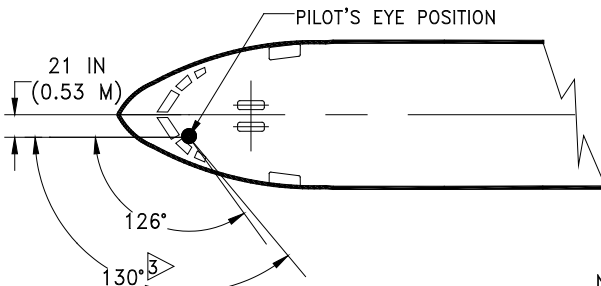

VISUAL ANGLES IN HORIZONTAL PLANE THROUGH PILOT'S EYE POSITION

NOTES: HEAD ROTATED ABOUT POINT 3.3 IN (0.08 M) AFT OF PILOT'S EYE POSITION

- 1 UPWARD VISION THROUGH MAIN WINDOW
- 2 DOWNWARD VISION THROUGH MAIN WINDOW
- 3 WITH HEAD MOVED 5 IN (0.13 M) OUTBOARD

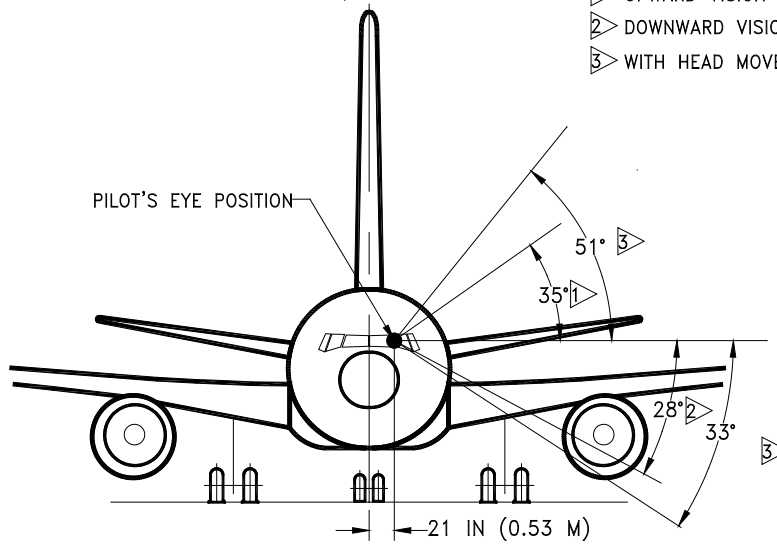

VISUAL ANGLES IN PLANE PERPENDICULAR TO LONGITUDINAL AXIS THROUGH PILOT'S EYE POSITION

4.5 RUNWAY AND TAXIWAY TURN PATHS

4.5.1 Runway and Taxiway Turnpaths - Runway-to-Taxiway, More Than 90 Degrees: Model 767-200, -200ER, -300, -300ER, -300 Freighter, -400ER

NOTE

BEFORE DETERMINING THE SIZE OF THE INTERSECTION FILLET, CHECK WITH THE AIRLINES REGARDING THE OPERATING PROCEDURES THAT THEY USE AND THE AIRCRAFT TYPES THAT ARE EXPECTED TO SERVE THE AIRPORT

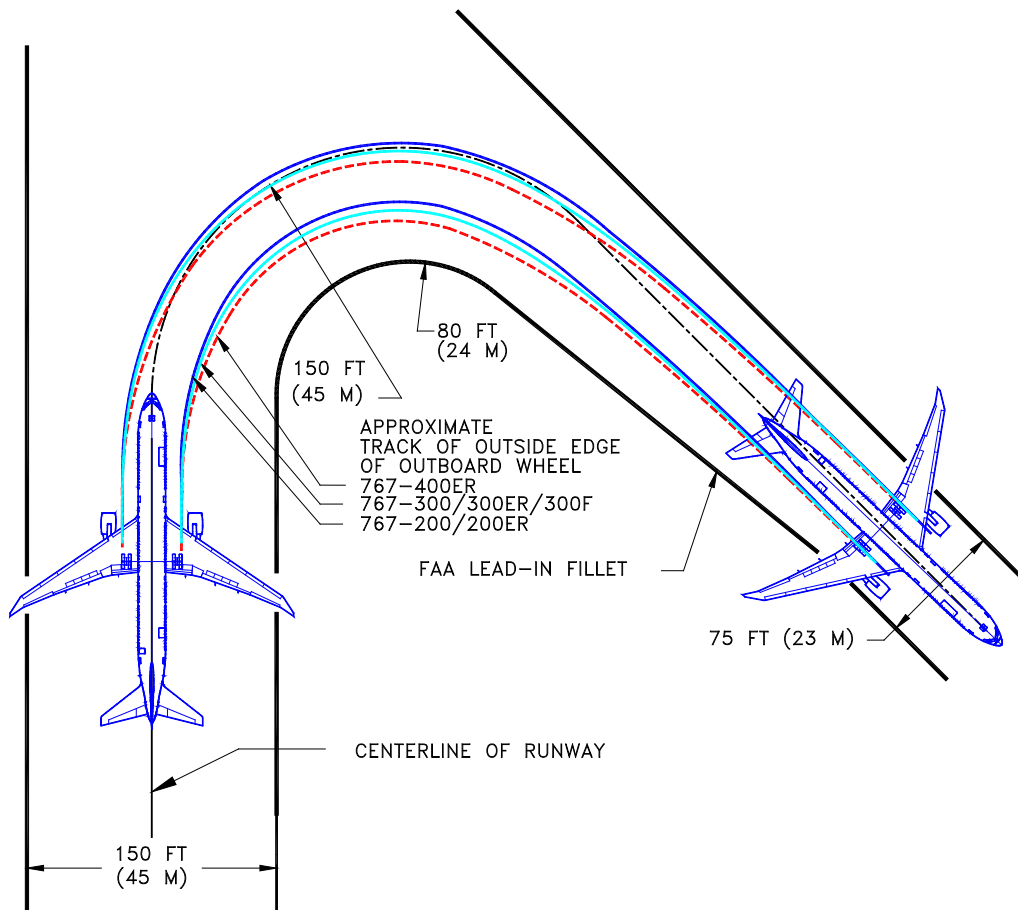

NOSE GEAR TRACKS
CENTERLINE OF TURNS

**4.5.2 Runway and Taxiway Turnpaths - Runway-to-Taxiway, 90 Degrees:
Model 767-200, -200ER, -300, -300ER, -300 Freighter, -400ER**

NOTE

BEFORE DETERMINING THE SIZE OF THE INTERSECTION FILLET, CHECK WITH THE AIRLINES REGARDING THE OPERATING PROCEDURES THAT THEY USE AND THE AIRCRAFT TYPES THAT ARE EXPECTED TO SERVE THE AIRPORT

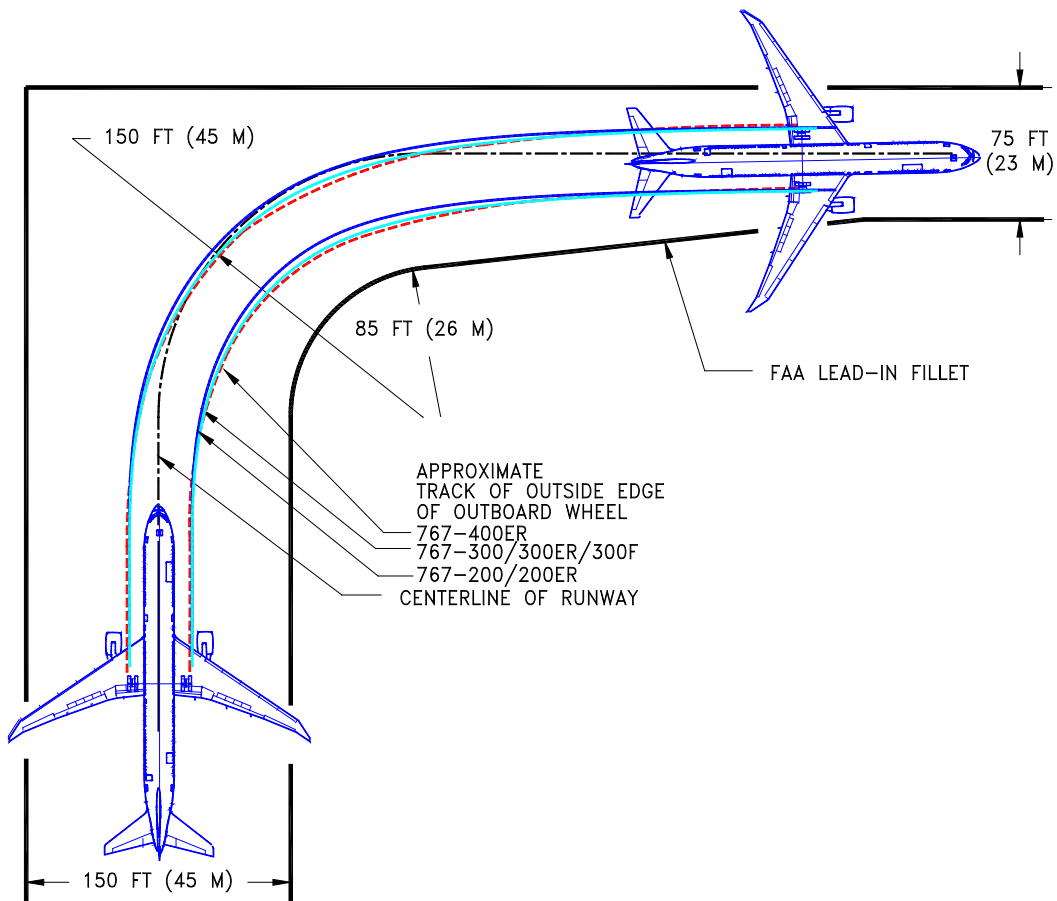

NOSE GEAR TRACKS
CENTERLINE OF TURNS

4.5.3 Runway and Taxiway Turnpaths - Taxiway-to-Taxiway, 90 Degrees, Nose Gear Tracks Centerline: Model 767-200, -200ER, -300, -300ER, -300 Freighter, -400ER

NOTE

BEFORE DETERMINING THE SIZE OF THE INTERSECTION FILLET, CHECK WITH THE AIRLINES REGARDING THE OPERATING PROCEDURES THAT THEY USE AND THE AIRCRAFT TYPES THAT ARE EXPECTED TO SERVE THE AIRPORT

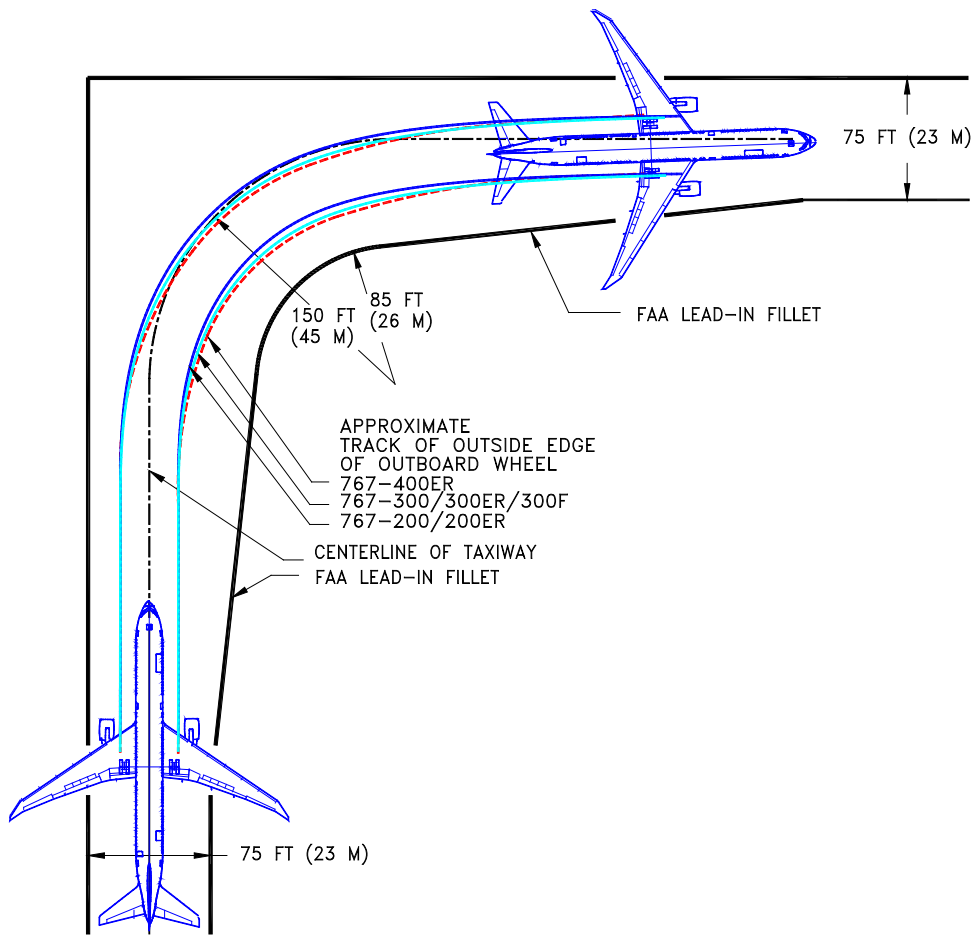

NOSE GEAR TRACKS
CENTERLINE OF TURNS

4.5.4 Runway and Taxiway Turnpaths - Taxiway-to-Taxiway, 90 Degrees, Cockpit Tracks Centerline: Model 767-200, -200ER, -300, -300ER, -300 Freighter, -400ER

NOTE

BEFORE DETERMINING THE SIZE OF THE INTERSECTION FILLET, CHECK WITH THE AIRLINES REGARDING THE OPERATING PROCEDURES THAT THEY USE AND THE AIRCRAFT TYPES THAT ARE EXPECTED TO SERVE THE AIRPORT

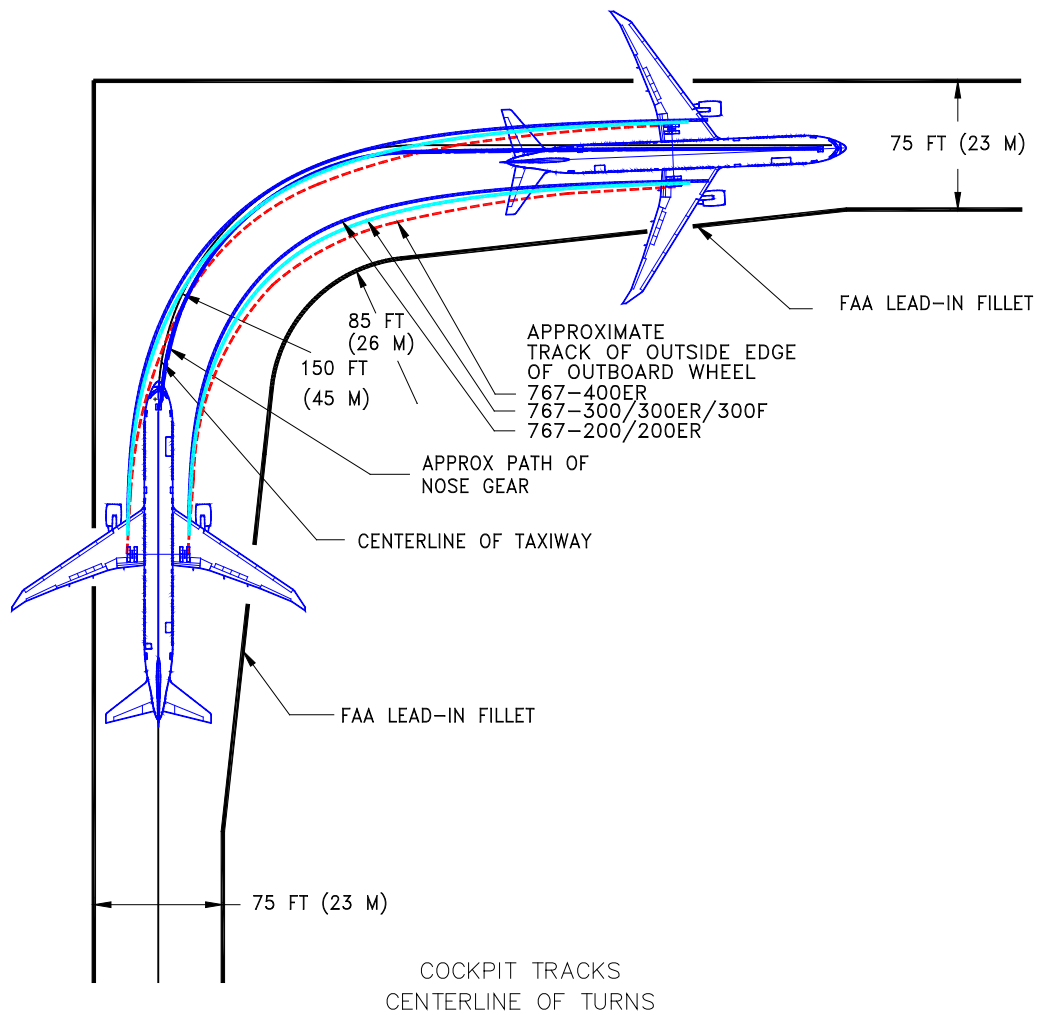

4.5.5 Runway and Taxiway Turnpaths - Taxiway-to-Taxiway, 90 Degrees, Judgmental Oversteer: Model 767-200, -200ER, -300, -300ER, -300 Freighter, -400ER

NOTE

BEFORE DETERMINING THE SIZE OF THE INTERSECTION FILLET, CHECK WITH THE AIRLINES REGARDING THE OPERATING PROCEDURES THAT THEY USE AND THE AIRCRAFT TYPES THAT ARE EXPECTED TO SERVE THE AIRPORT

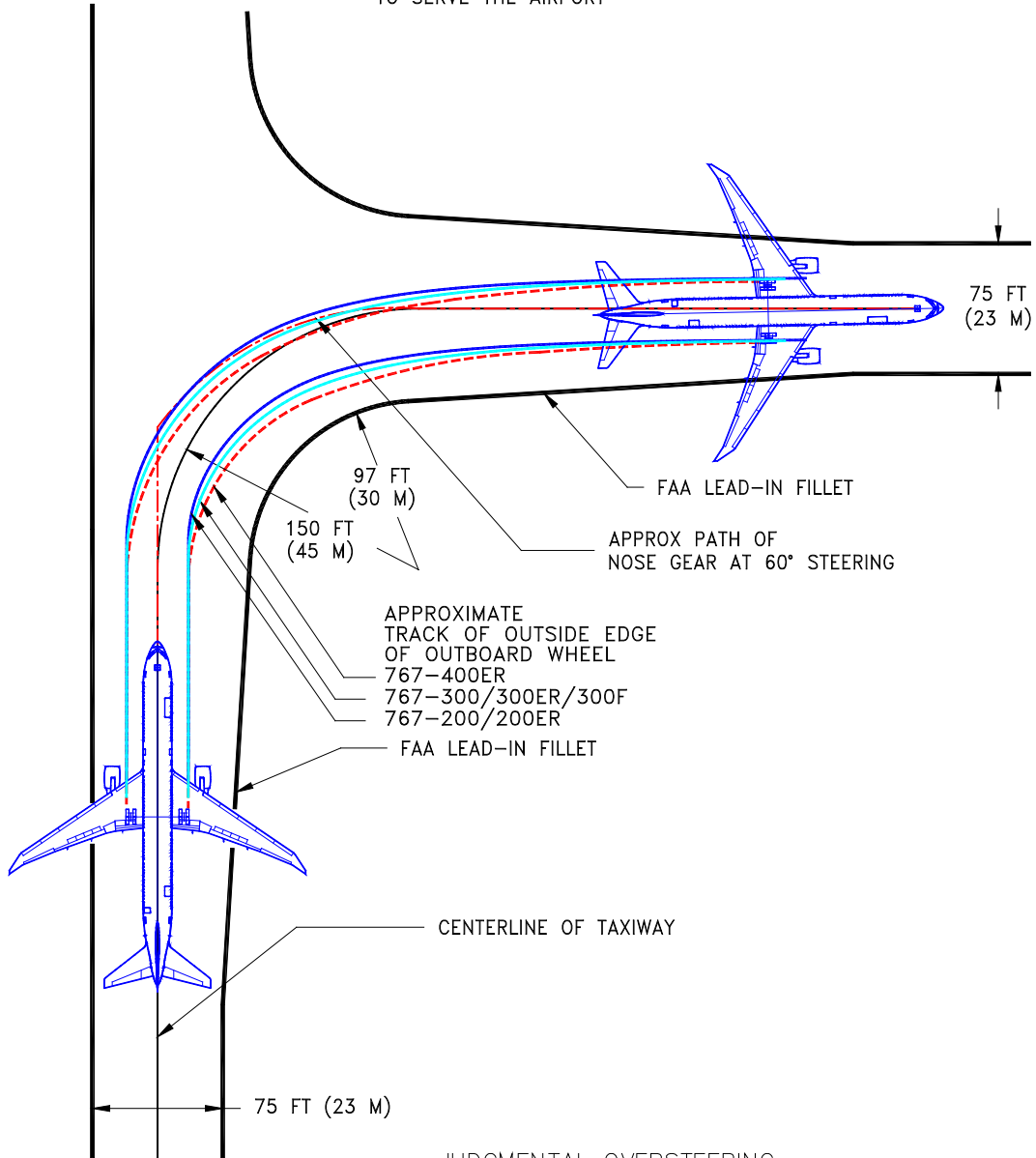

JUDGMENTAL OVERSTEERING
NOSE GEAR TRACKING BEYOND
CENTERLINE OF TURNS

4.6 RUNWAY HOLDING BAY: MODEL 767-200, -200ER, -300, -300ER, -300 FREIGHTER, -400ER

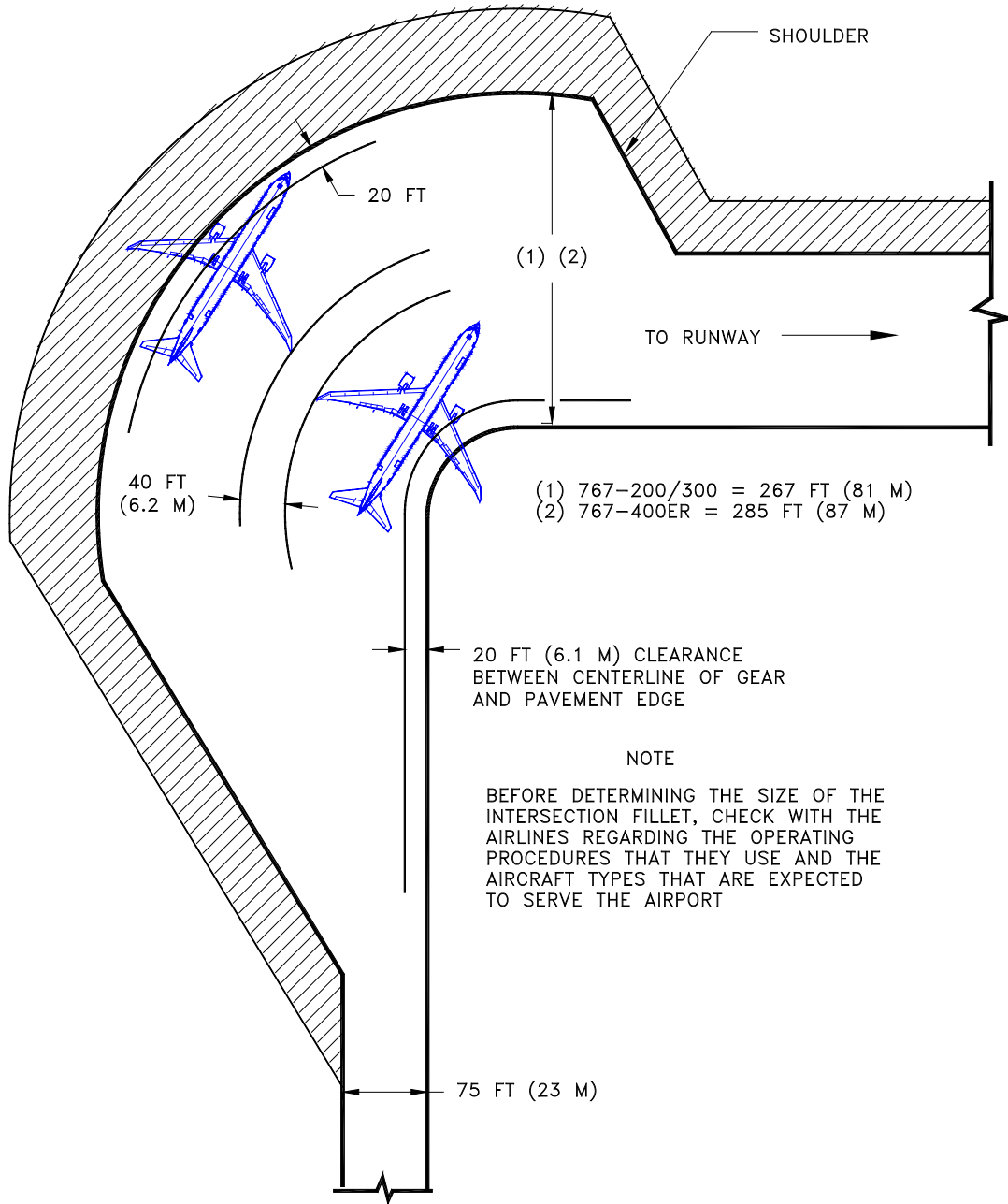

5.0 TERMINAL SERVICING

During turnaround at the terminal, certain services must be performed on the aircraft, usually within a given time, to meet flight schedules. This section shows service vehicle arrangements, schedules, locations of service points, and typical service requirements. The data presented in this section reflect ideal conditions for a single airplane. Service requirements may vary according to airplane condition and airline procedure.

Section 5.1 shows typical arrangements of ground support equipment during turnaround. As noted, if the auxiliary power unit (APU) is used, the electrical, air start, and air-conditioning service vehicles would not be required. Passenger loading bridges or portable passenger stairs could be used to load or unload passengers.

Sections 5.2 and 5.3 show typical service times at the terminal. These charts give typical schedules for performing service on the airplane within a given time. Service times could be rearranged to suit availability of personnel, airplane configuration, and degree of service required.

Section 5.4 shows the locations of ground service connections in graphic and in tabular forms. Typical capacities and service requirements are shown in the tables. Services with requirements that vary with conditions are described in subsequent sections.

Section 5.5 shows typical sea level air pressure and flow requirements for starting different engines. The curves are based on an engine start time of 90 seconds.

Section 5.6 shows air conditioning requirements for heating and cooling (pull-down and pull-up) using ground conditioned air. The curves show airflow requirements to heat or cool the airplane within a given time at ambient conditions.

Section 5.7 shows air conditioning requirements for heating and cooling to maintain a constant cabin air temperature using low pressure conditioned air. This conditioned air is supplied through an 8-in (20.3 cm) ground air connection (GAC) directly to the passenger cabin, bypassing the air cycle machines.

Section 5.8 shows ground towing requirements for various ground surface conditions.

5.1 AIRPLANE SERVICING ARRANGEMENT - TYPICAL TURNAROUND

5.1.1 Airplane Servicing Arrangement - Typical Turnaround: Model 767-200, -200ER

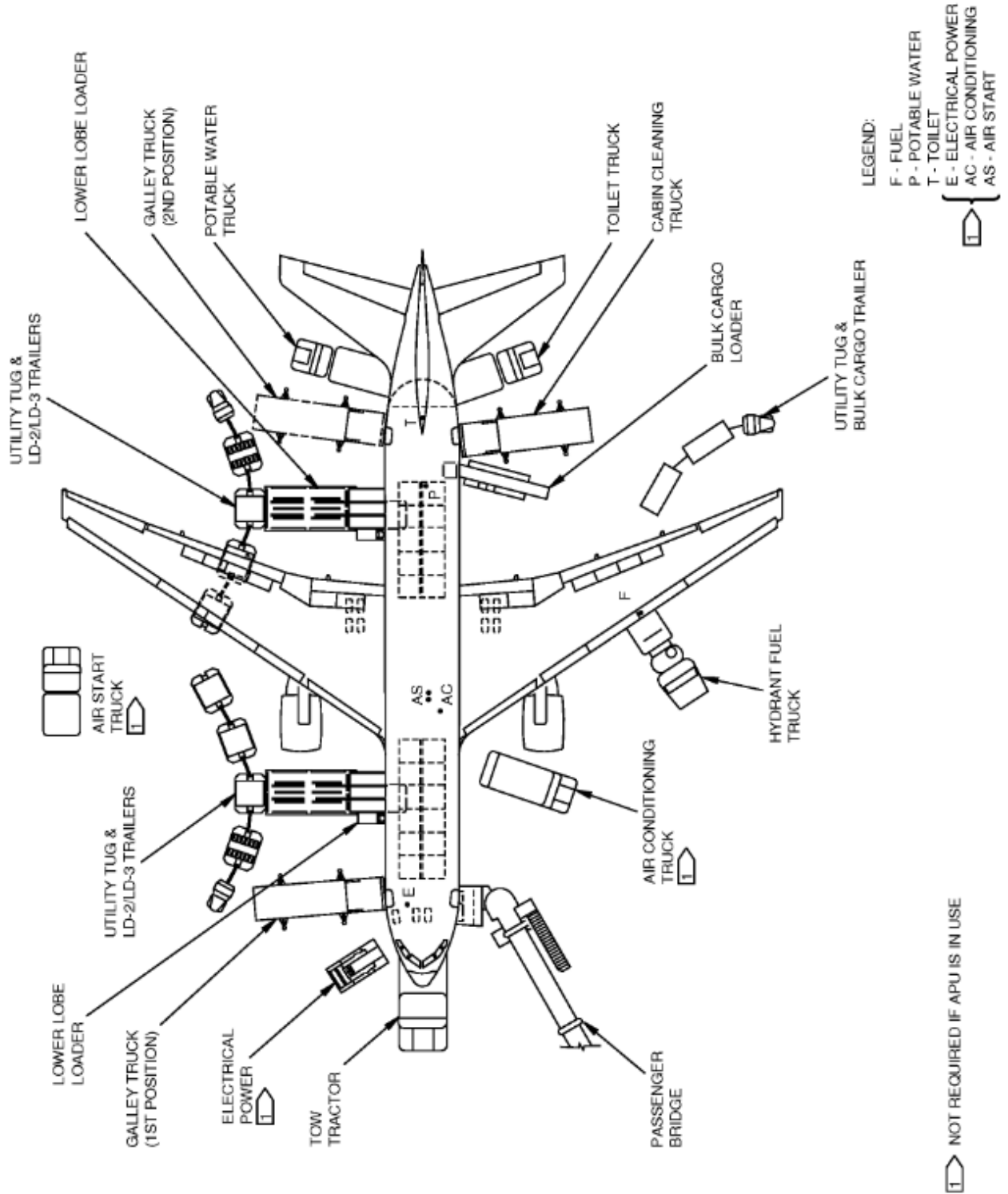

D6-58328

5.1.2 Airplane Servicing Arrangement - Typical Turnaround: Model 767-300, -300ER

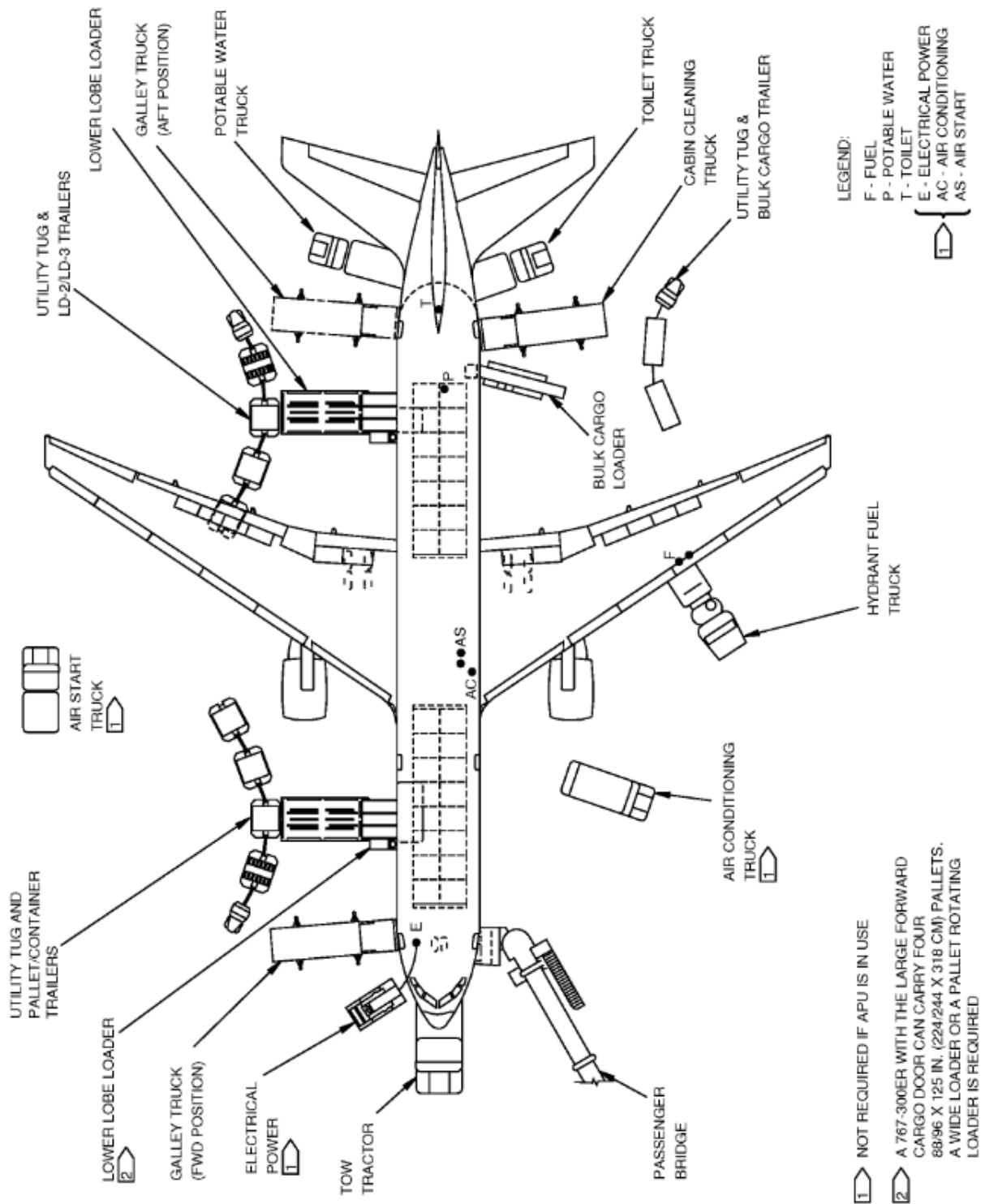

D6-58328

5.1.3 Airplane Servicing Arrangement - Typical Turnaround: Model 767-300, Freighter

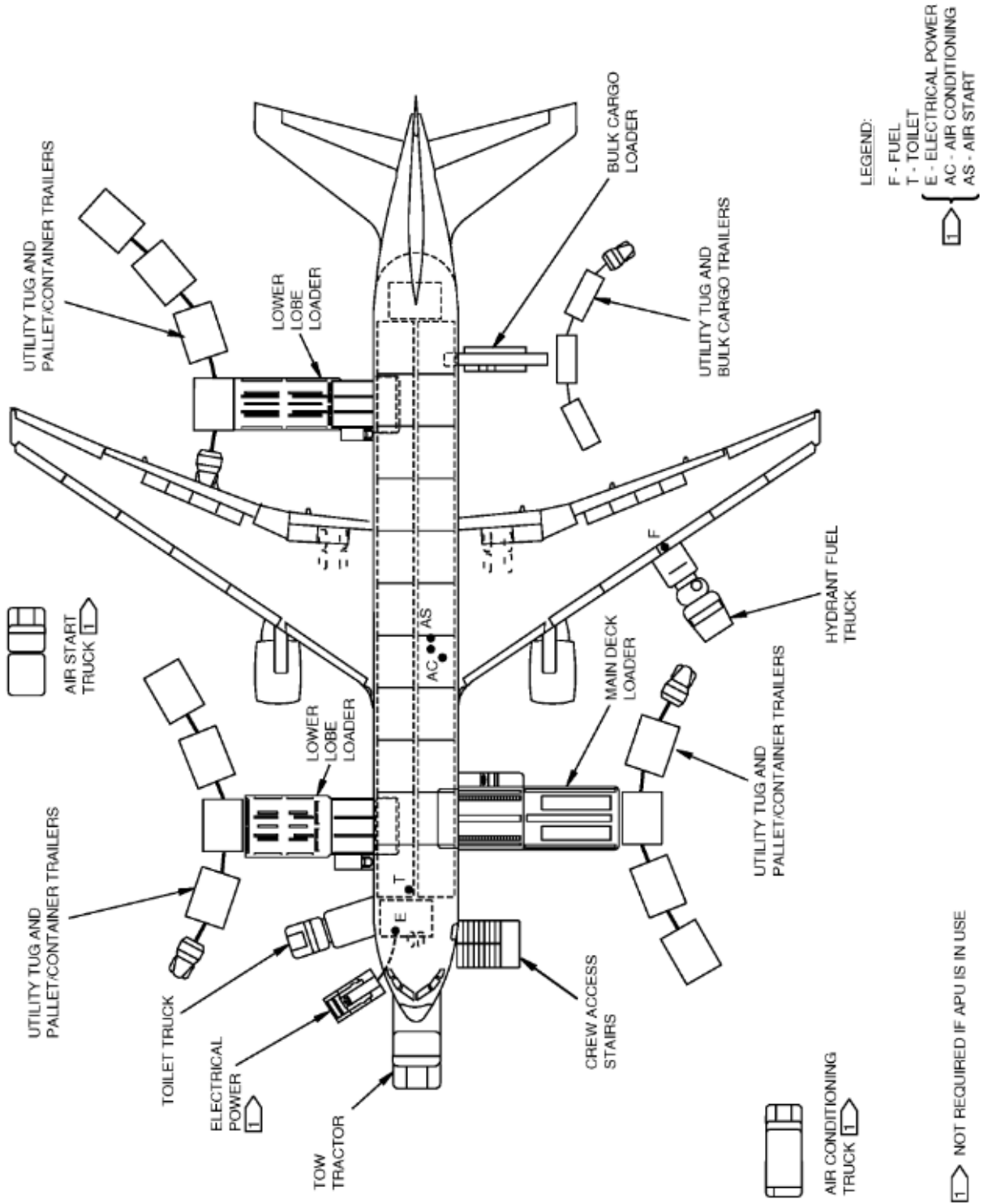

D6-58328

REV I

July 2021

5-4

5.1.4 Airplane Servicing Arrangement - Typical Turnaround: Model 767-400ER

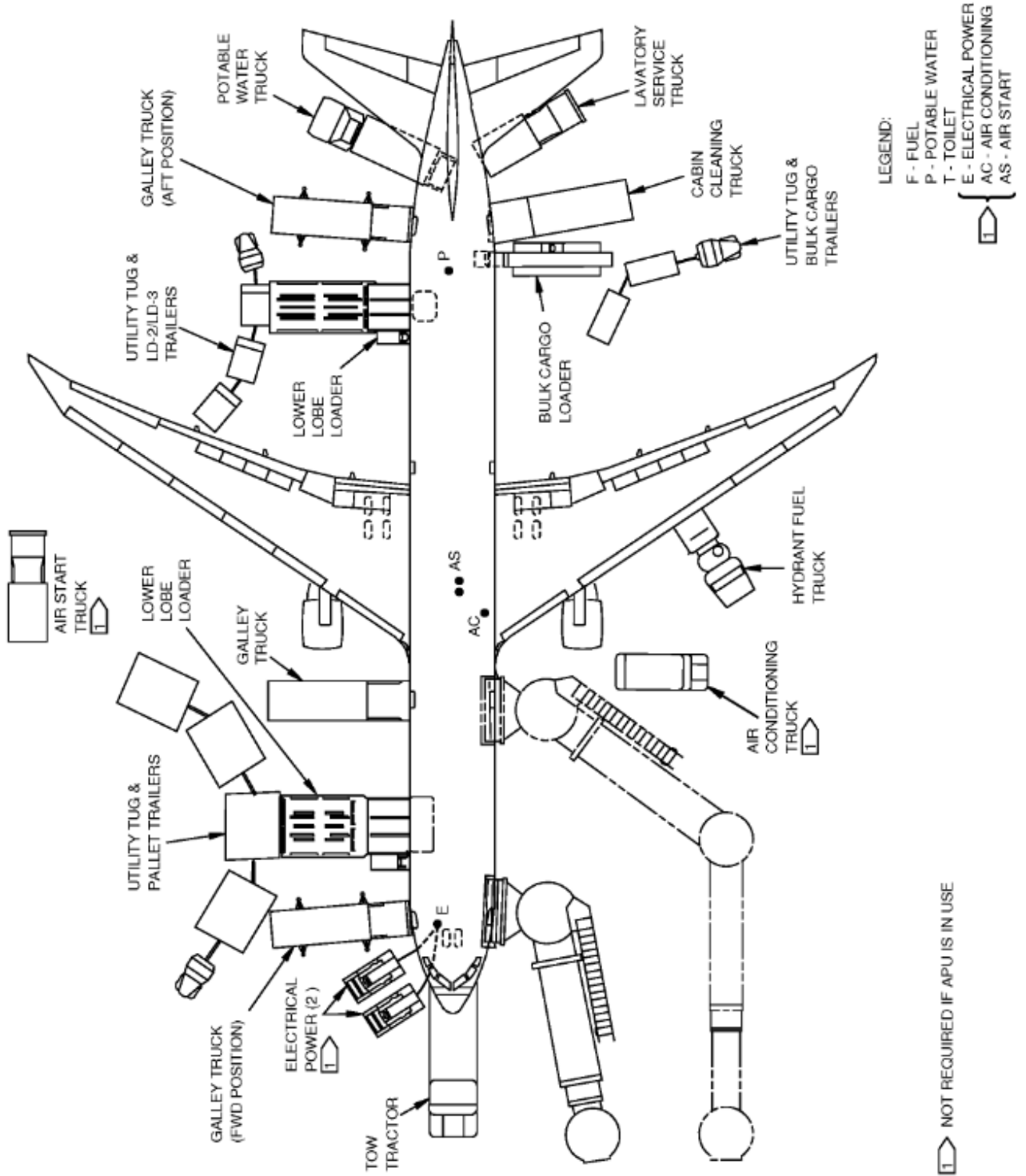

D6-58328

5.2 TERMINAL OPERATIONS - TURNAROUND STATION

5.2.1 Terminal Operations - Turnaround Station - All Passenger: Model 767-200, -200ER – 2 Class

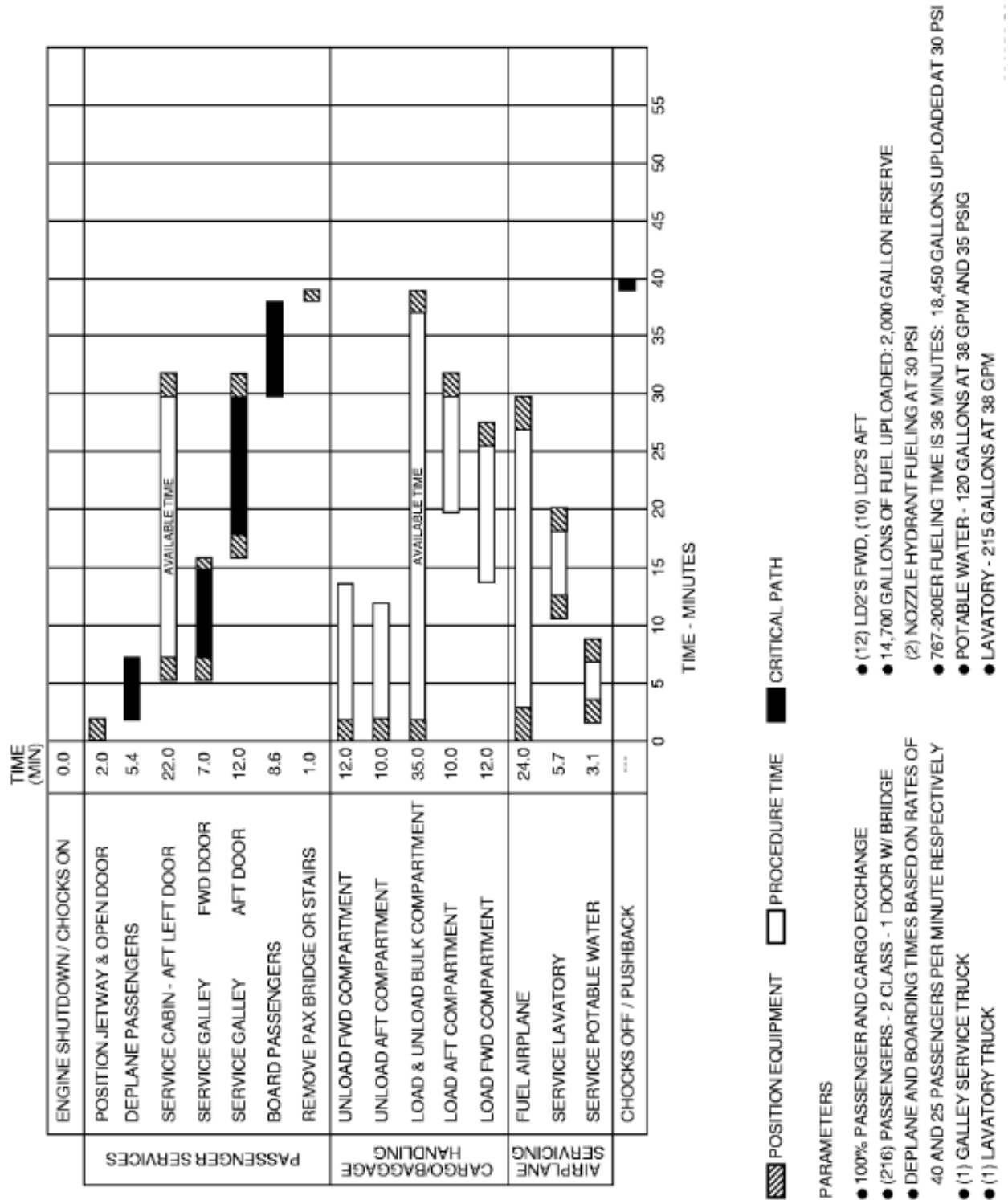

5.2.2 Terminal Operations - Turnaround Station - All Passenger: Model 767-200, -200ER – 3 Class

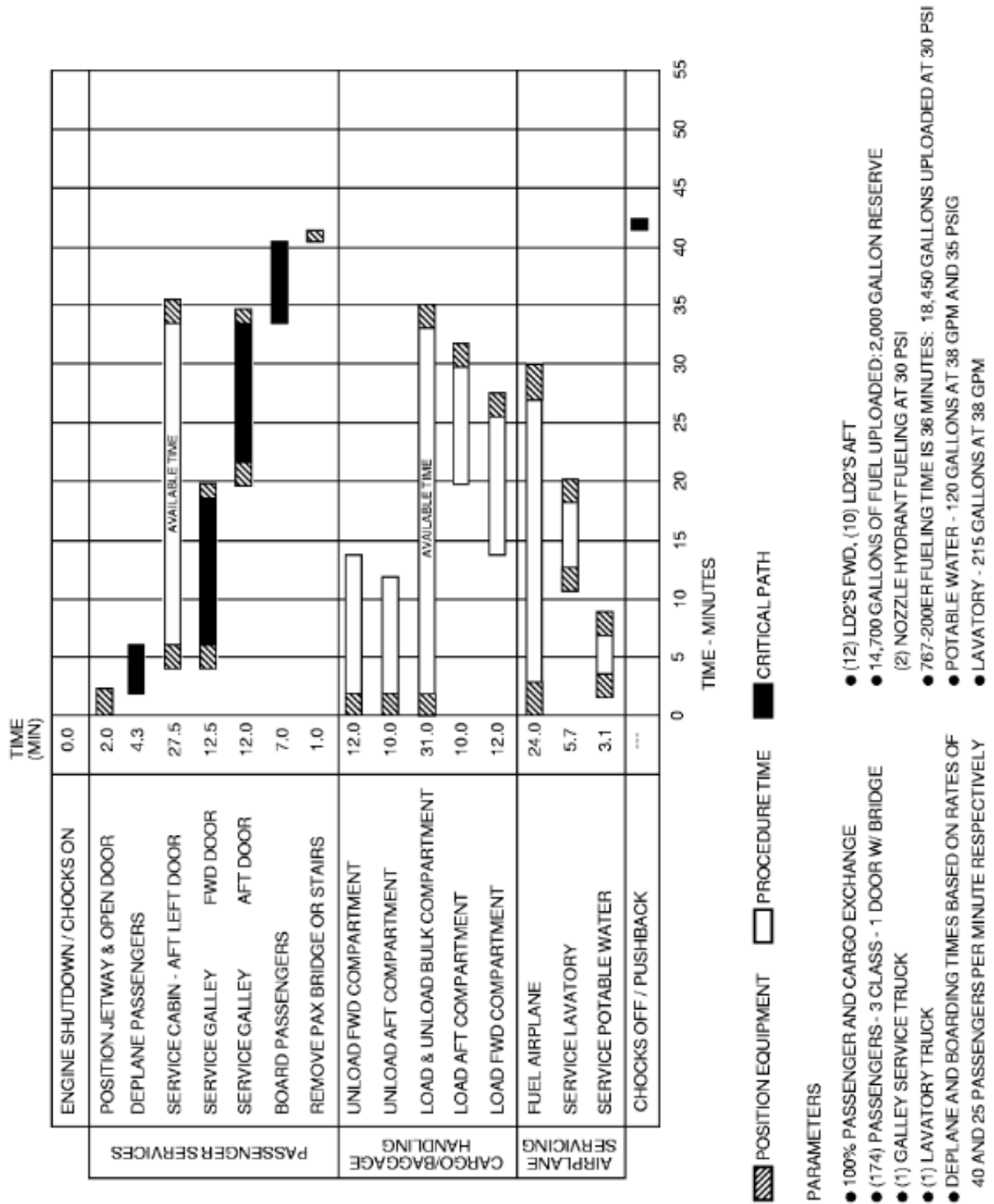

D6-58328

REV I

July 2021

5-7

5.2.3 Terminal Operations - Turnaround Station - All Passenger: Model 767-300, -300ER – 2 Class

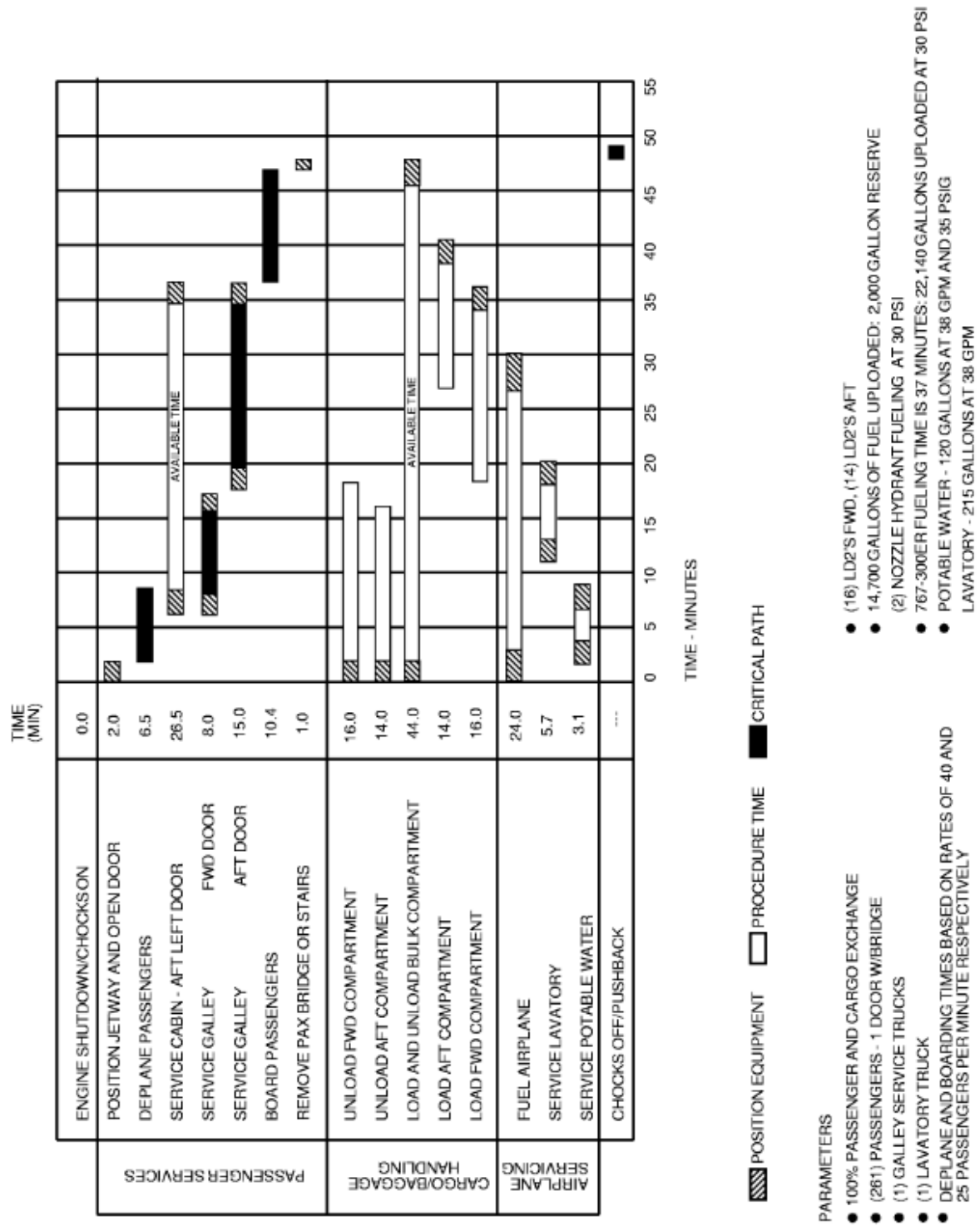

5.2.4 Terminal Operations - Turnaround Station - All Passenger: Model 767-300, -300ER – 3 Class

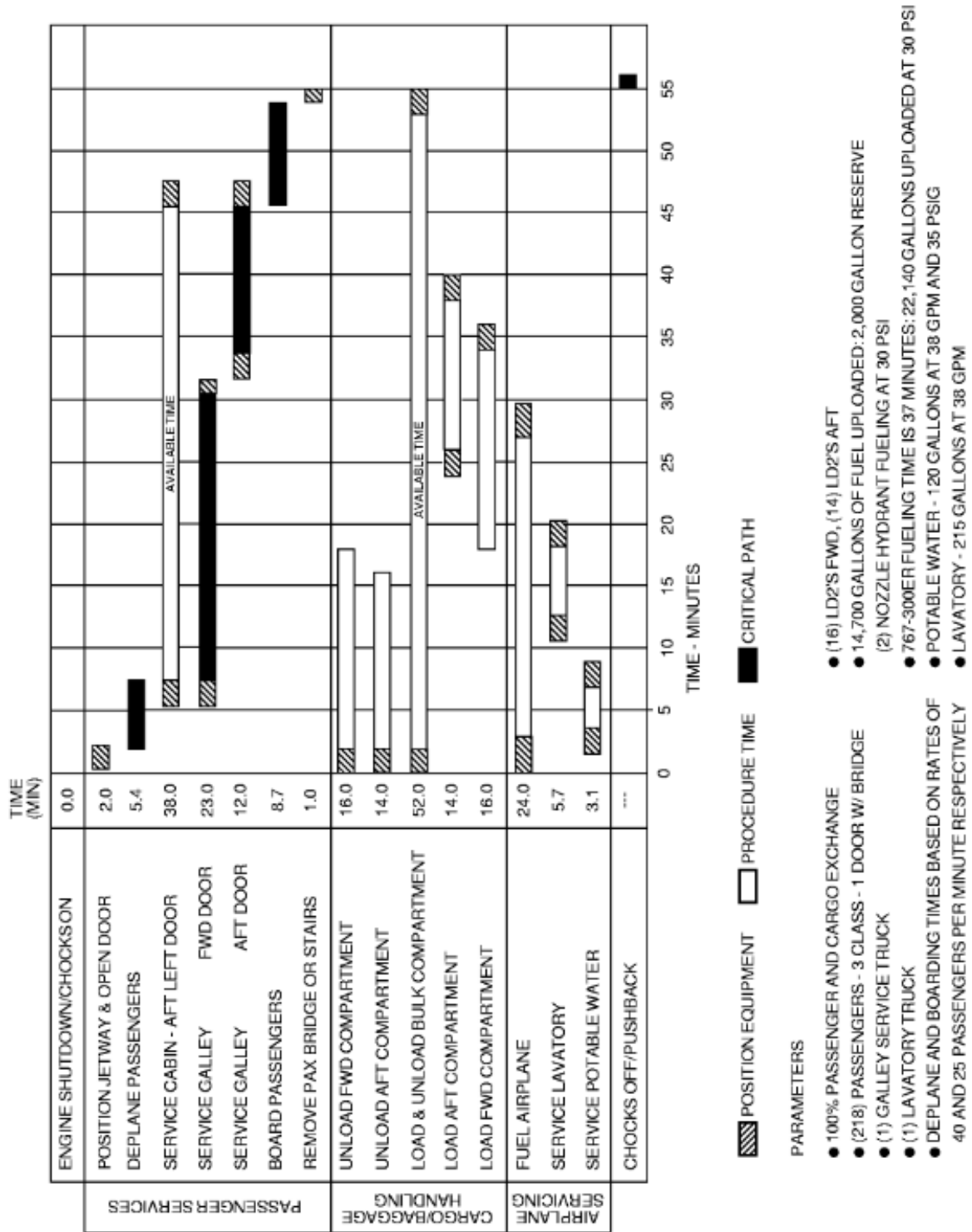

D6-58328

5.2.5 Terminal Operations - Turnaround Station - All Passenger: Model 767-300 Freighter

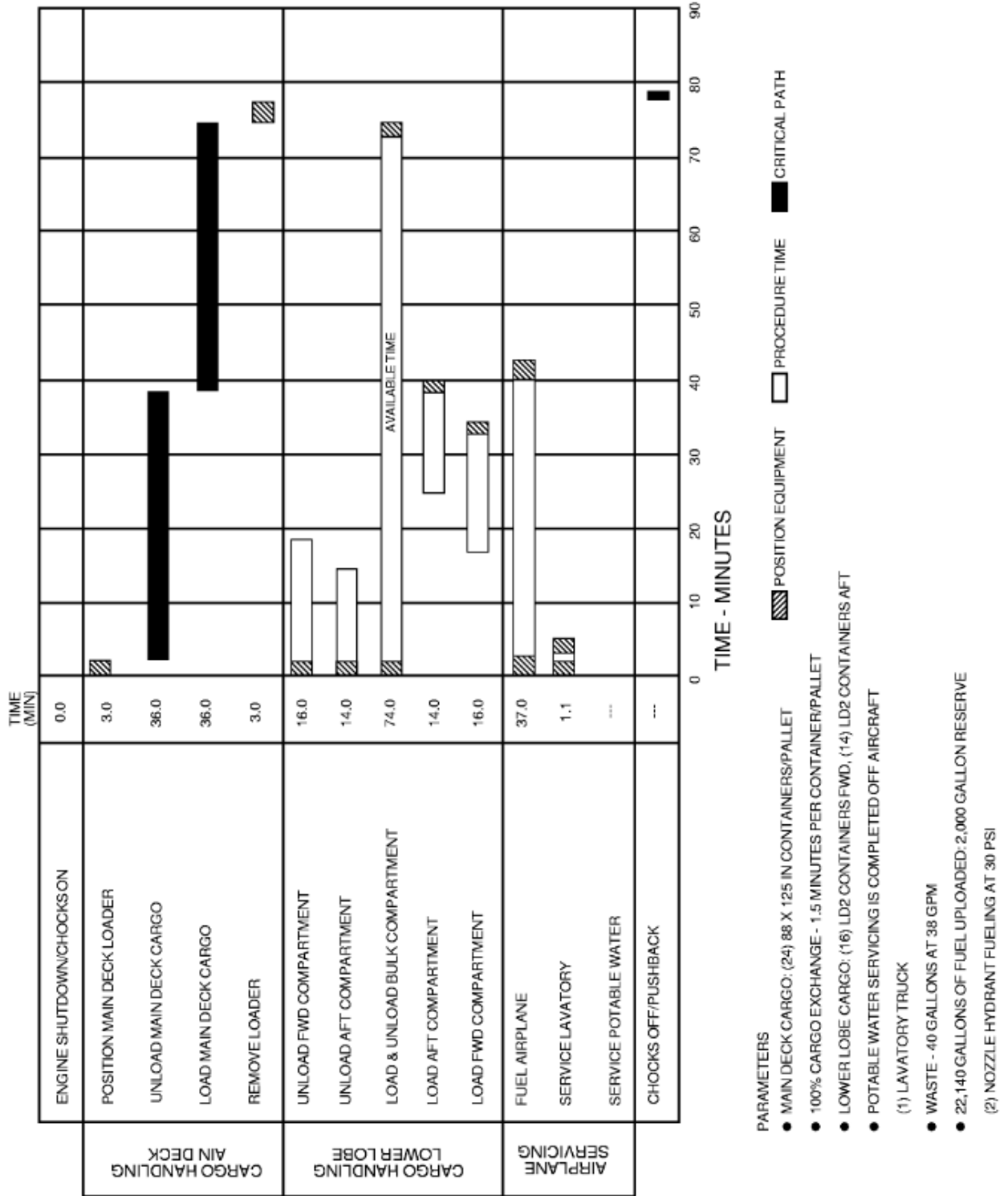

D6-58328

REV I

July 2021

5-10

5.2.6 Terminal Operations - Turnaround Station - All Passenger: Model 767-400ER – 2 Class

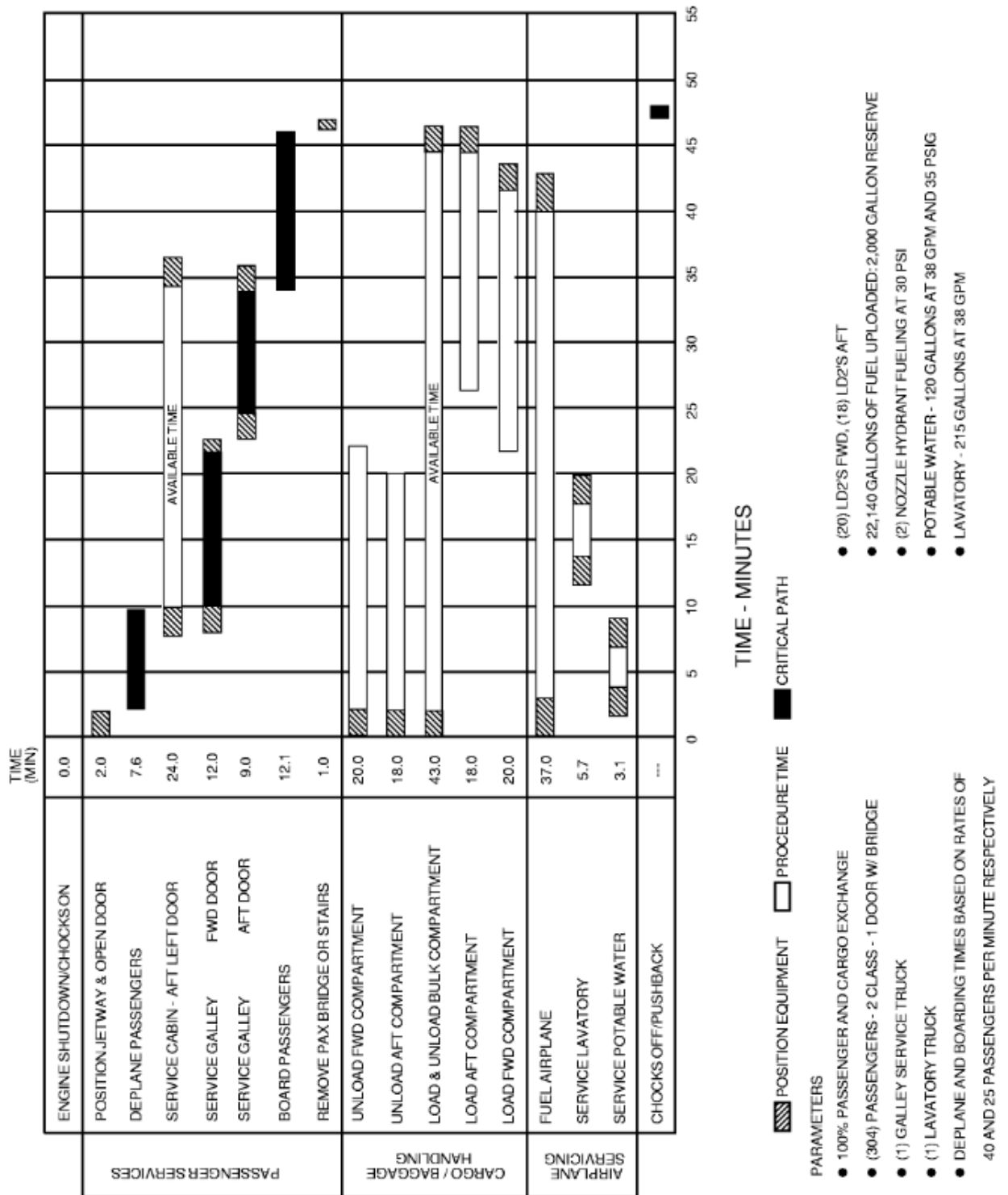

D6-58328

REV I

July 2021

5-11

5.2.7 Terminal Operations - Turnaround Station - All Passenger: Model 767-400ER – 3 Class

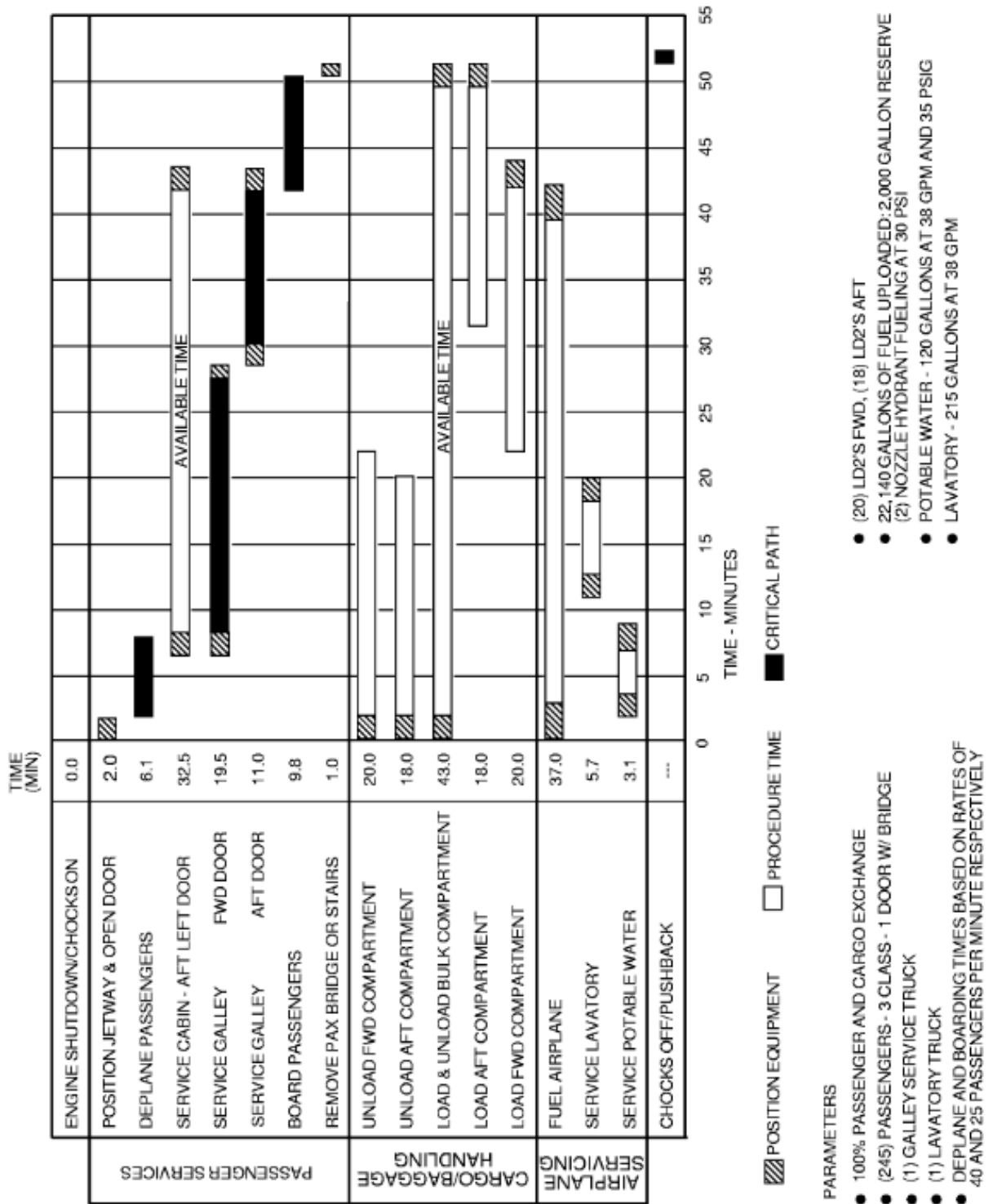

D6-58328

REV I

July 2021

5-12

5.3 TERMINAL OPERATIONS - EN ROUTE STATION

5.3.1 Terminal Operations - En Route Station - All Passenger: Model 767-200, -200ER

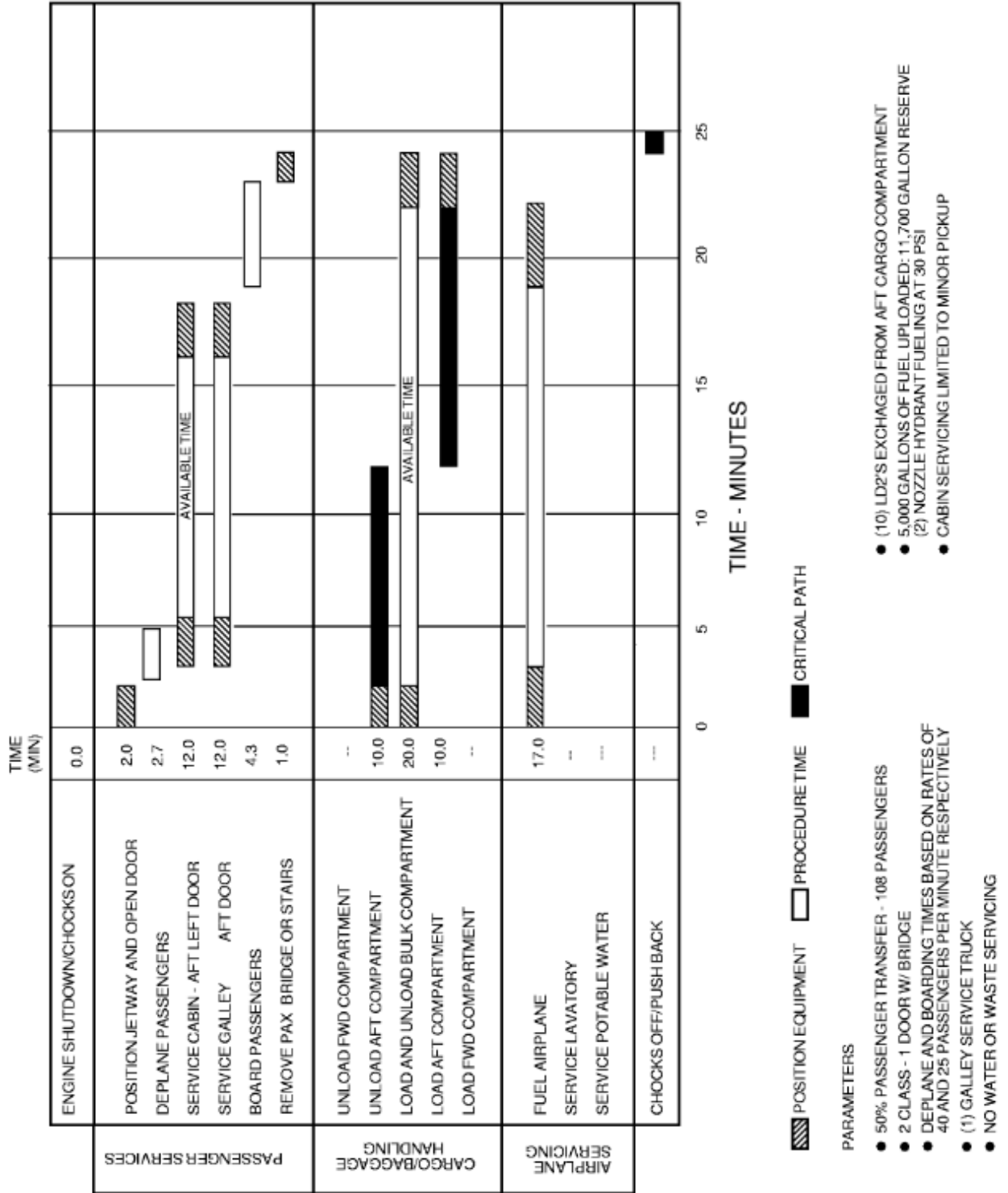

5.3.2 Terminal Operations - En Route Station - All Passenger: Model 767-300, -300ER

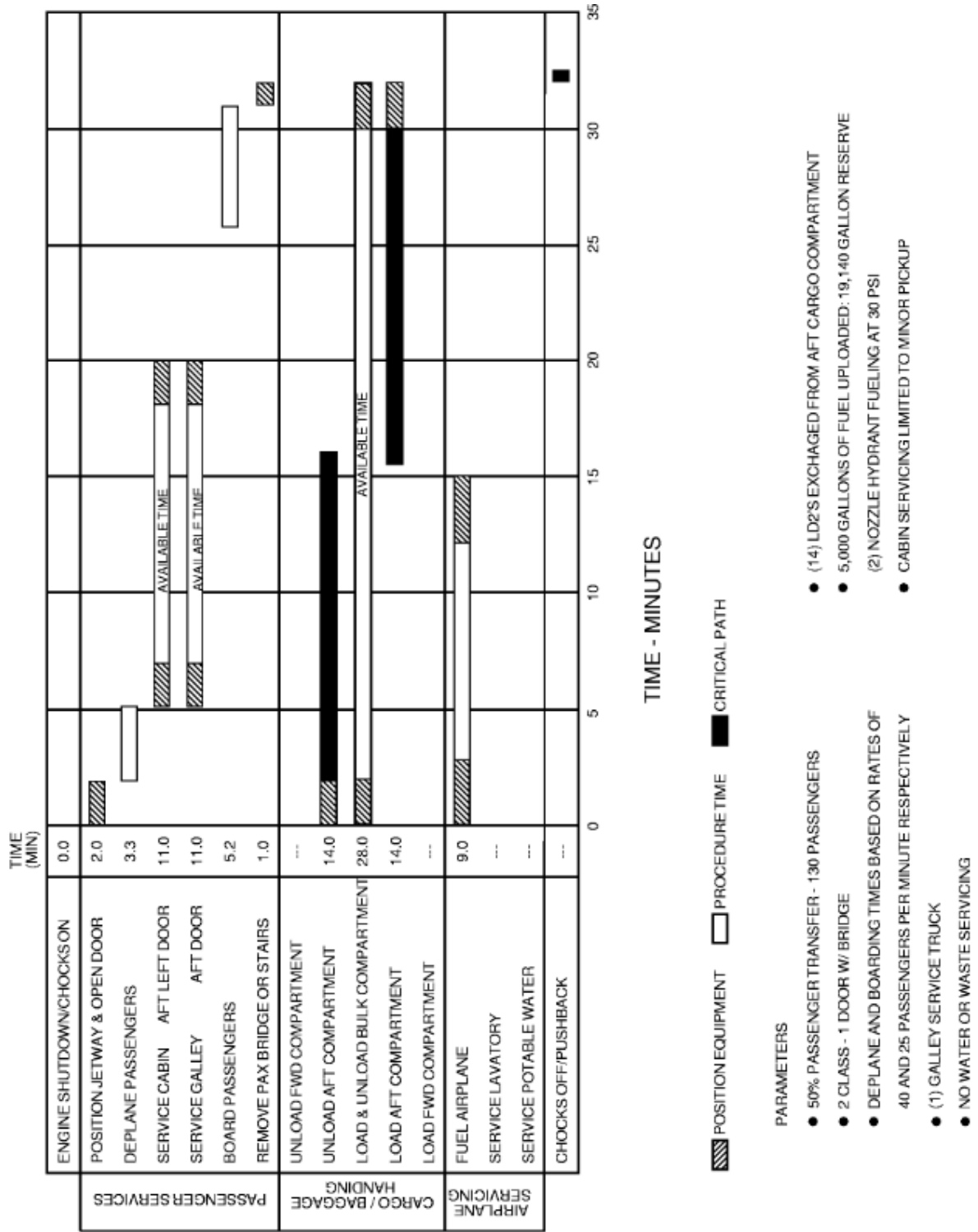

5.3.3 Terminal Operations - En Route Station - All Passenger: Model 767-400ER

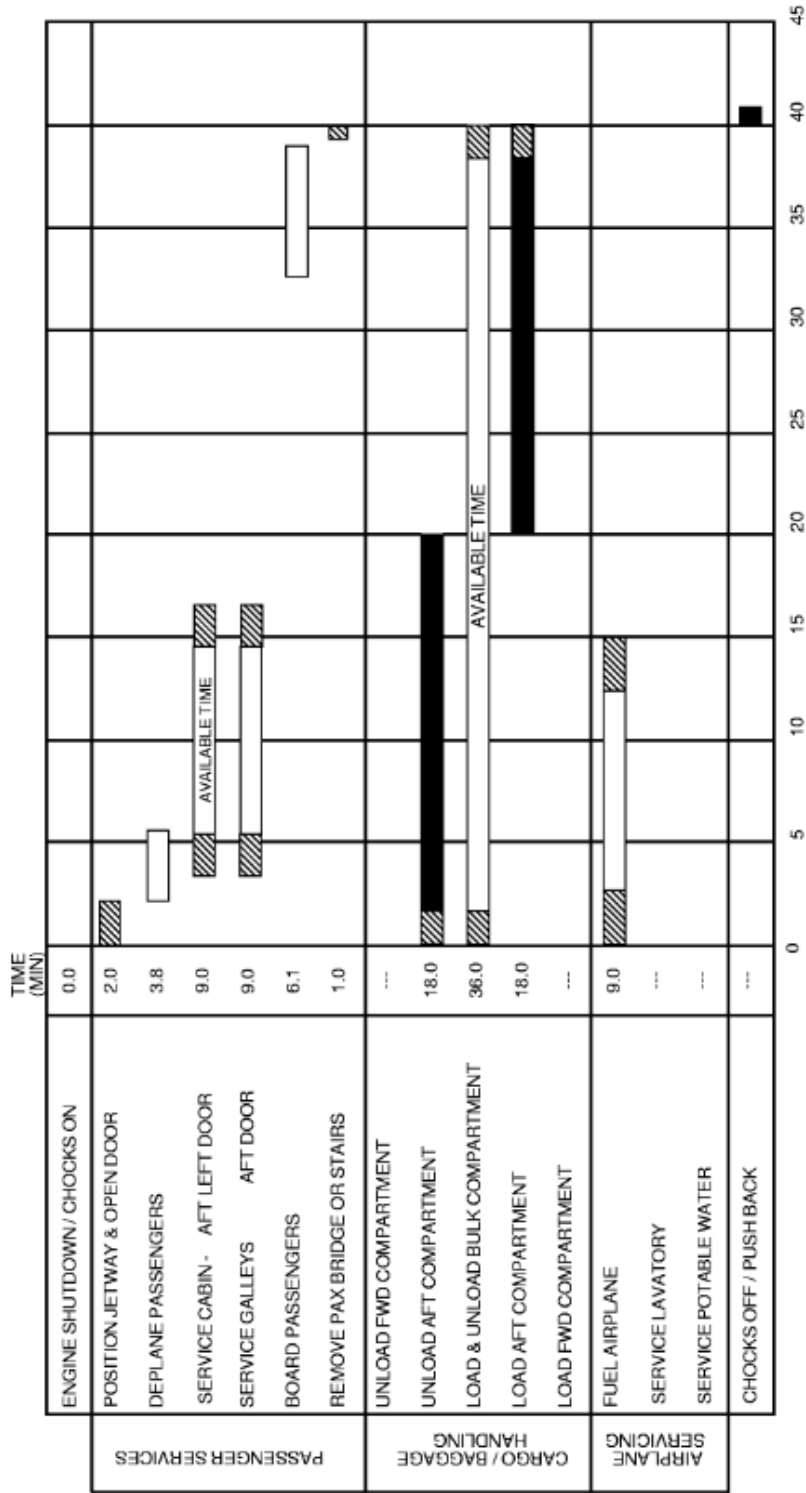

TIME - MINUTES

- ▨ POSITION EQUIPMENT
 - PROCEDURE TIME
 - CRITICAL PATH
- PARAMETERS
- 50% PASSENGER TRANSFER - 152 PASSENGERS
 - 2 CLASS - 1 DOOR W/ BRIDGE
 - DEPLANE AND BOARDING TIMES BASED ON RATES OF 40 AND 25 PASSENGERS PER MINUTE RESPECTIVELY
 - (1) GALLEY SERVICE TRUCK
 - NO WATER OR WASTE SERVICING
- (18) LD2'S EXCHANGED FROM AFT CARGO COMPARTMENT
 - 5,000 GALLONS OF FUEL UNLOADED: 19,140 GALLON RESERVE
 - (2) NOZZLE HYDRANT FUELING AT 30 PSI
 - CABIN SERVICING LIMITED TO MINOR PICKUP

5.4 GROUND SERVICING CONNECTIONS

5.4.1 Ground Service Connections: Model 767-200, -200ER

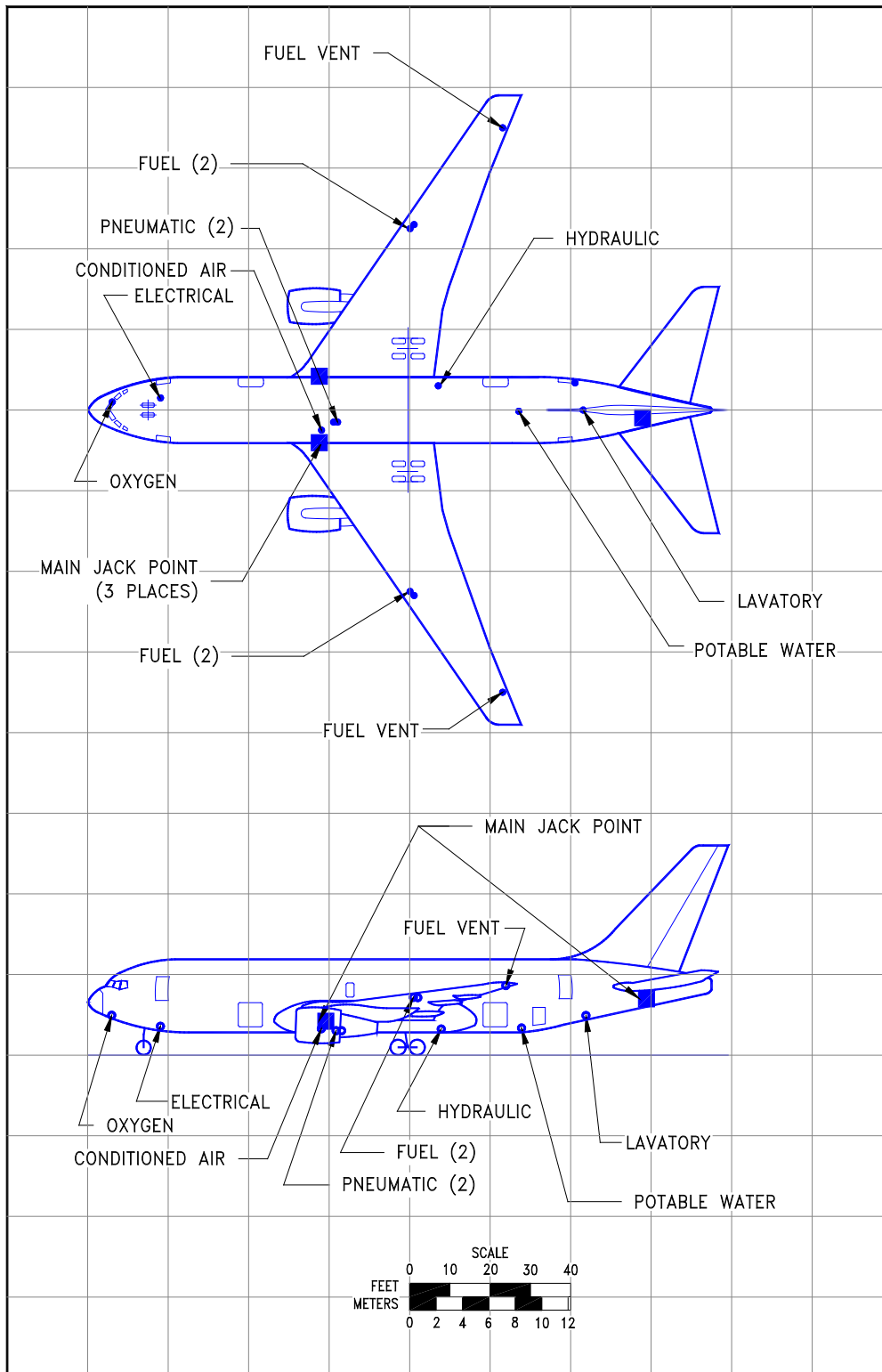

D6-58328

REV I

July 2021

5-16

5.4.2 Ground Service Connections: -300, -300ER

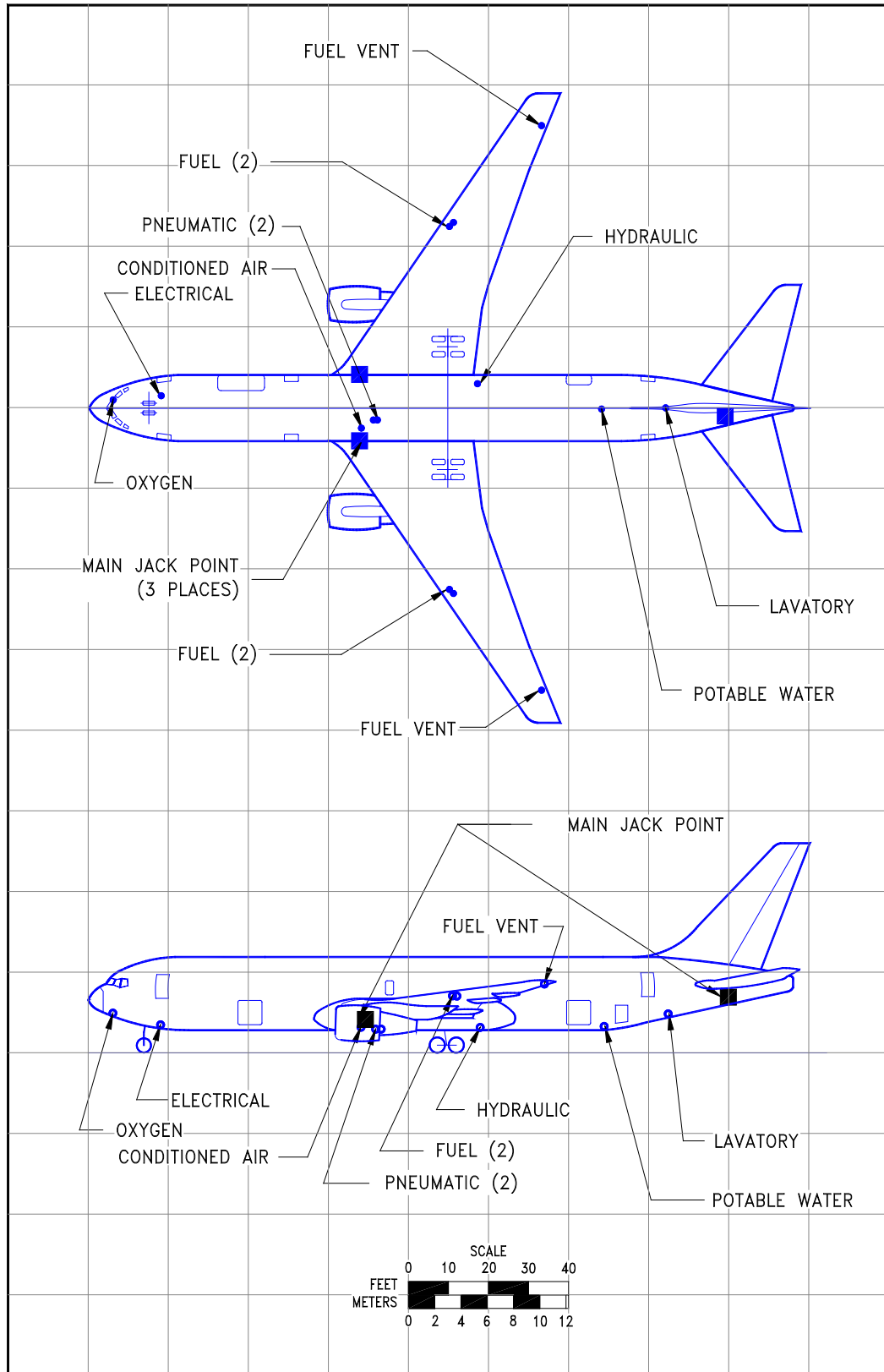

D6-58328

REV I

July 2021

5-17

5.4.3 Ground Service Connections: Model 767-300 Freighter

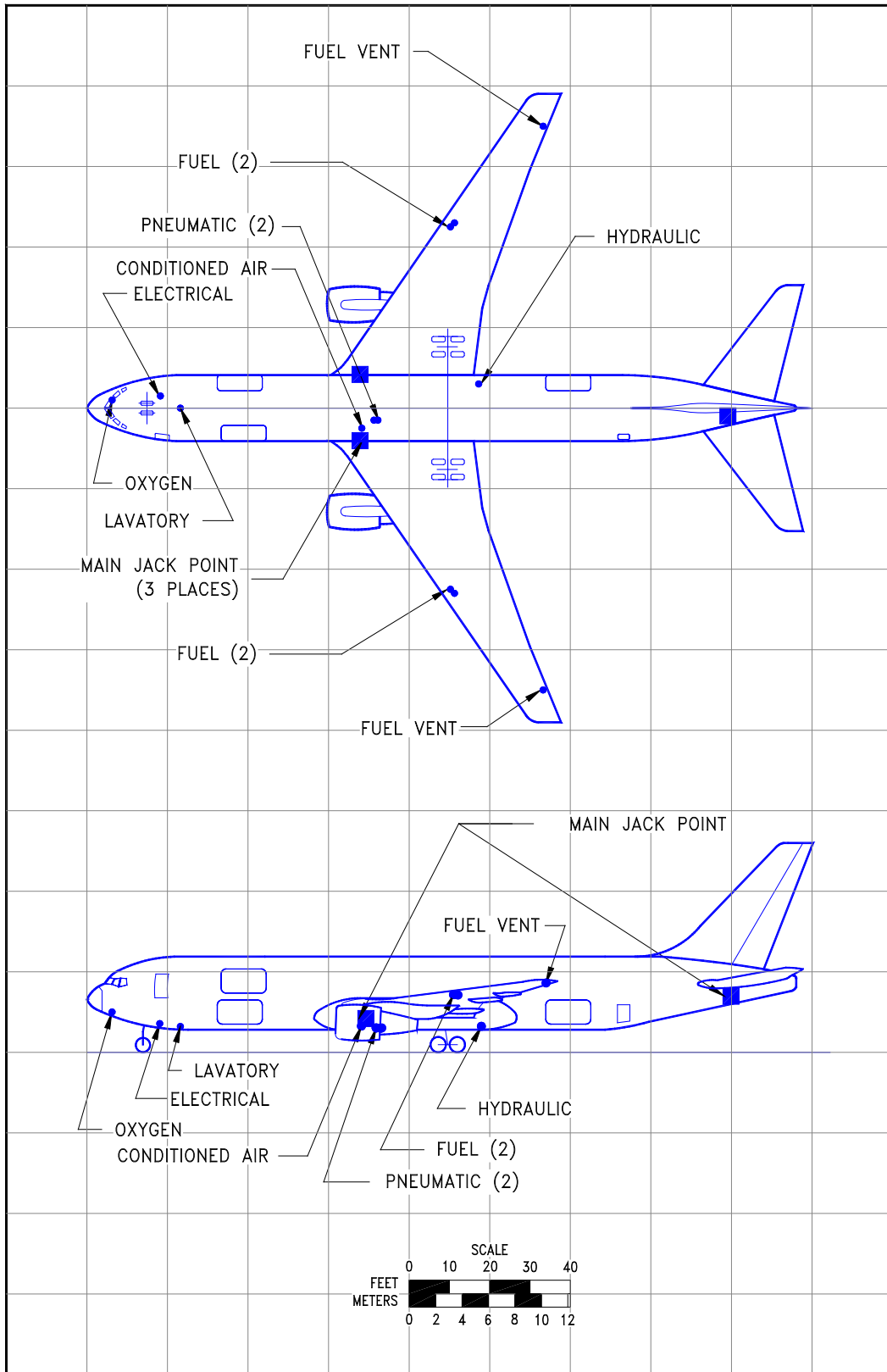

D6-58328

5.4.4 Ground Service Connections: Model 767-400ER

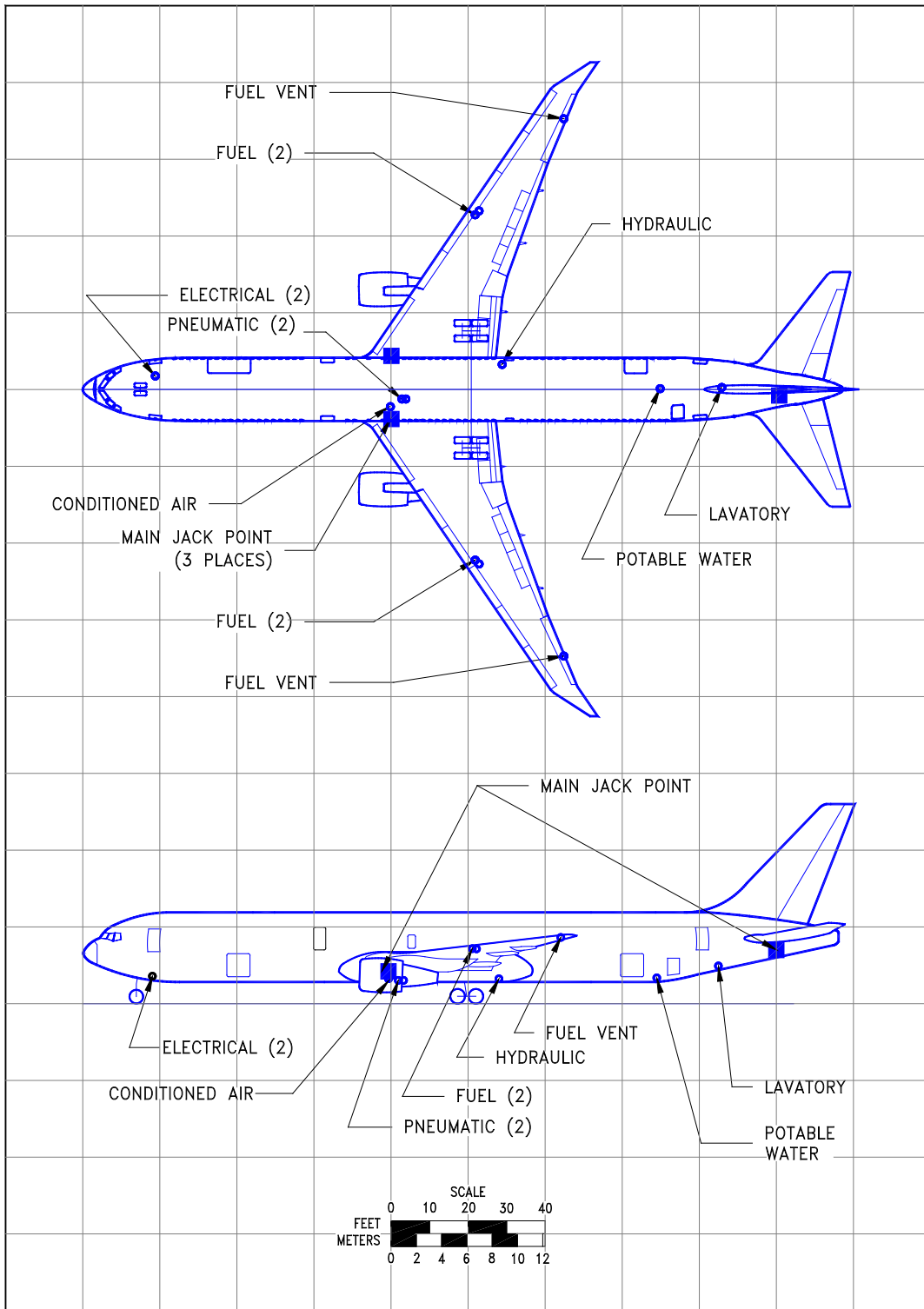

D6-58328

5.4.5 Ground Service Connections and Capacities: Model 767-200, -200ER, -300, -300ER, -300 Freighter, -400ER

SYSTEM	MODEL	DISTANCE AFT OF NOSE		DISTANCE FROM AIRPLANE CENTERLINE				HEIGHT ABOVE GROUND		
				LH SIDE		RH SIDE				
		FT	M	FT	M	FT	M	FT	M	
CONDITIONED AIR ONE 8-IN (20.3 CM) PORT	-200, -200ER	58	17.7	5	1.5	-	-	7	2.1	
	-300, -300ER, -300 F	68	20.8	5	1.5	-	-	7	2.1	
	-400ER	79	24.1	5	1.5	-	-	7	2.1	
ELECTRICAL ONE CONNECTION* 90 KVA , 200/115 V AC 400 HZ, 3-PHASE *767-400ER HAS TWO CONNECTIONS	ALL	18	5.5	-	-	3	0.9	7	2.1	
FUEL TWO UNDERWING PRESSURE CONNECTORS ON EACH WING	-200, -200ER,	80	24.4	45	13.7	45	13.7	15	4.5	
		81	24.7	46	14.0	46	14.0	15	4.5	
	-300, -300ER, -300 F	90	27.4	45	13.7	45	13.7	15	4.5	
		91	27.7	46	14.0	46	14.0	15	4.5	
	-400ER	101	30.8	45	13.7	45	13.7	14	4.3	
		102	31.1	46	14.0	46	14.0	15	4.5	
FUEL VENTS	-200, -200ER,	103	31.4	70	21.3	70	21.3	17	5.2	
		-300, -300ER,	113	34.4	70	21.3	70	21.3	17	5.2
			-400ER	124	37.8	70	21.3	70	21.3	17
TOTAL TANK CAPACITY: -200, -300, -300 FREIGHTER 16,700 U.S. GAL (63,210 L)										
-200ER 20,450 U.S. GAL (77,410 L)										
-300ER, -400ER 24,140 U.S. GAL (91,370 L)										
MAX FUEL RATE: 1,000 GPM (3,970 LPM)										
MAX FILL PRESSURE: 55 PSIG (3.87 KG/CM ²)										

5.4.6 Ground Service Connections and Capacities: Model 767-200, -200ER, -300, -300ER, -300 Freighter, -400ER

SYSTEM	MODEL	DISTANCE AFT OF NOSE		DISTANCE FROM AIRPLANE CENTERLINE				HEIGHT ABOVE GROUND	
				LH SIDE		RH SIDE			
		FT	M	FT	M	FT	M	FT	M
HYDRAULIC ONE SERVICE CONNECTION TOTAL SYSTEM CAPACITY = 80 GAL (303 L) FILL PRESSURE = 150 PSIG (10.55 KG/CM ²)	-200, -200ER								
	-300, -300ER, -300 F -400ER								
LAVATORY BOTH FORWARD AND AFT TOILETS ARE SERVICED THROUGH ONE SERVICE PANEL THREE SERVICE CONNECTIONS: DRAIN – ONE 4 IN (10.2 CM) FLUSH – TWO 1 IN (2.5 CM) TOILET FLUSH REQUIREMENTS: FLOW – 10 GPM (38 LPM) PRESSURE 30 PSIG (2.11 KG/SC CM) TOTAL SERVICE TANK REQUIREMENTS: WASTE – 140 US GAL (530 L) FLUSH – 50 US GAL (189 L) PRECHARGE – 12 US GAL (45 L)	-200, -200ER,	123	37.5	0	0	0	0	10	3.0
	-300, -300ER, -300 F	144	43.9	0	0	0	0	10	3.0
	-400ER	165	50.3	0	0	0	0	10	3.0
OXYGEN CREW SYSTEM USES REPLACEABLE CYLINDERS PASSENGER SYSTEM USES SELF-CONTAINED OXYGEN GENERATION UNITS	ALL	6	1.8	-	-	2	0.6	10	3.0
	ALL								
PNEUMATIC TWO 3-IN(7.6-CM) PORTS	-200, -200ER	61	18.6	3	0.9	-	-	7	2.1
		62	18.9	3	0.9	-	-	7	2.1
	-300, -300ER, -300 F	71	21.6	3	0.9	-	-	7	2.1
		72	21.9	3	0.9	-	-	7	2.1
	-400ER	82	25.0	3	0.9	-	-	7	2.1
		83	25.3	3	0.9	-	-	7	2.1

5.4.7 Ground Service Connections and Capacities: Model 767-200, -200ER, -300, -300ER, -300 Freighter, -400ER

SYSTEM	MODEL	DISTANCE AFT OF NOSE		DISTANCE FROM AIRPLANE CENTERLINE				HEIGHT ABOVE GROUND	
				LH SIDE		RH SIDE			
		FT	M	FT	M	FT	M	FT	M
POTABLE WATER ONE SERVICE CONNECTION (BASIC)	-200, -200ER,	107	32.6	0.3	0.1	-	-	7	2.1
OPTIONAL LOCATION ONE SERVICE CONNECTION (BASIC)	-200, -300, -300ER, -300F	121	36.8	0.3	0.1	8	2.4	18	5.5
	-400ER	149	44.4	0.3	0.1	-	-	7	2.1
FORWARD DRAIN PANEL	ALL	46	14.0	0.3	0.1	-	-	7	2.1
TANK CAPACITY 102 U.S. GAL (386 L)	-200, -300							7	2.1
149 U.S. GAL (564 L)	-200ER, -300ER, -400ER								
FILL PORT – ¾ IN (1.9 CM) MAX FILL PRESSURE = 25 PSIG (1.76 KG/SQ CM)									

5.5 ENGINE STARTING PNEUMATIC REQUIREMENTS

5.5.1 Engine Start Pneumatic Requirements - Sea Level: Model 767-200, -200ER, -300, -300ER, -300 Freighter, -400ER (GE Engines)

NOTES:

- ALTITUDE = SEA LEVEL
- GARRETT STARTER MODEL ATS200-58
- USE OF TWO GROUND CONNECTIONS IS ASSUMED
- PROVIDES MINIMUM ENGINE STARTING REQUIREMENTS

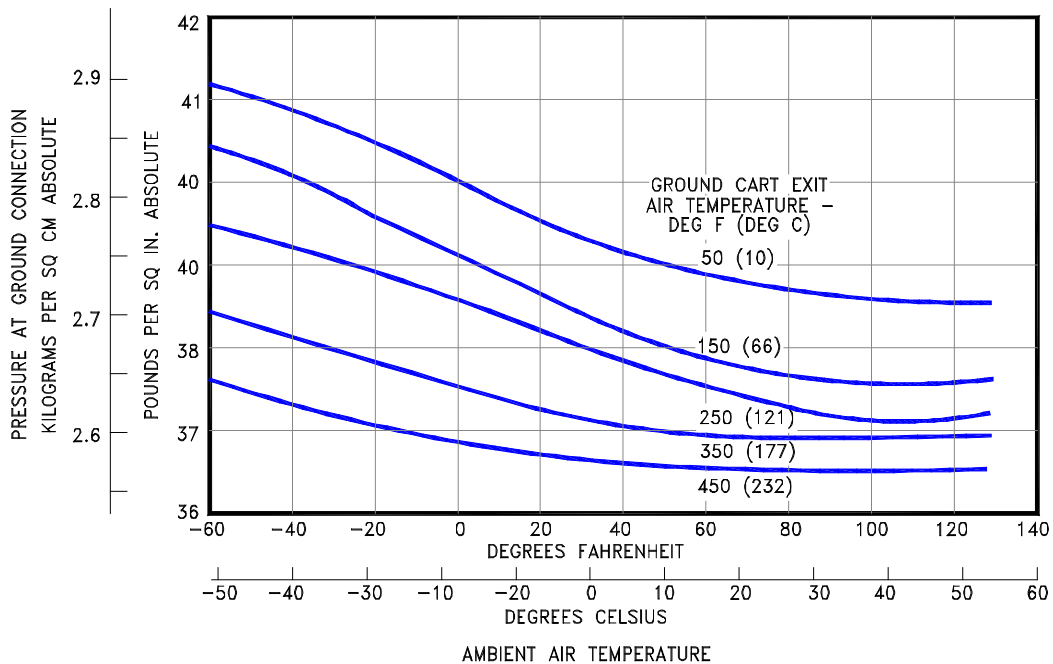
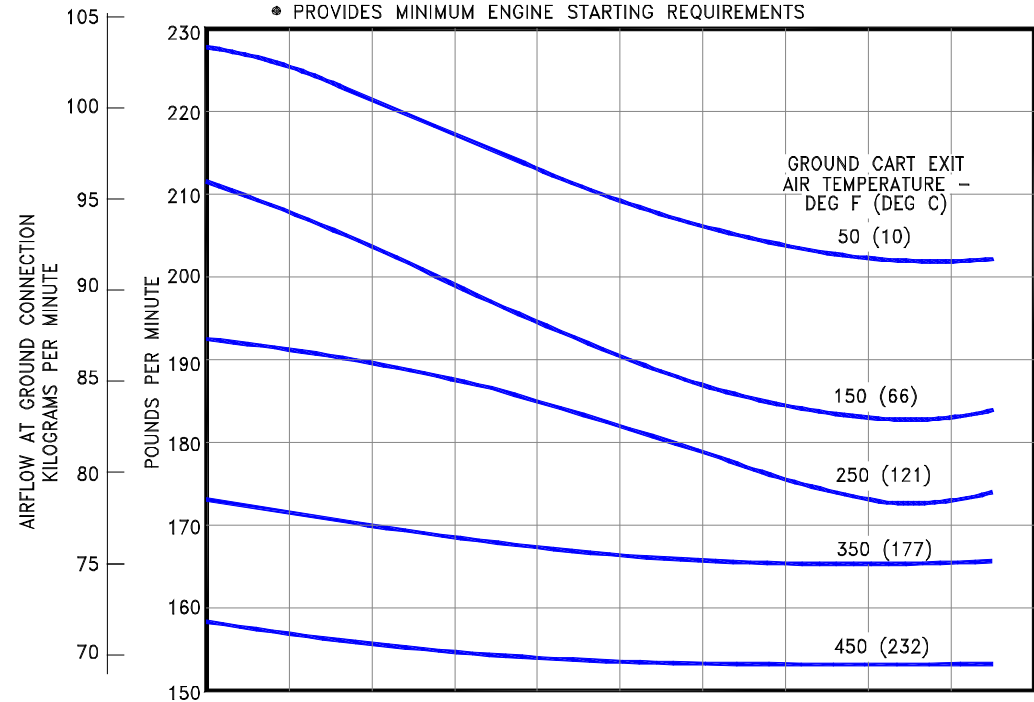

5.5.2 Engine Start Pneumatic Requirements - Sea Level: Model 767-200, -200ER, -300, -300ER, -300 Freighter, -400ER (P&W Engines)

NOTES:

- ALTITUDE = SEA LEVEL
- HAMILTON STANDARD STARTER MODEL PS700-5
- USE OF TWO GROUND CONNECTIONS IS ASSUMED
- PROVIDES MINIMUM ENGINE STARTING REQUIREMENTS

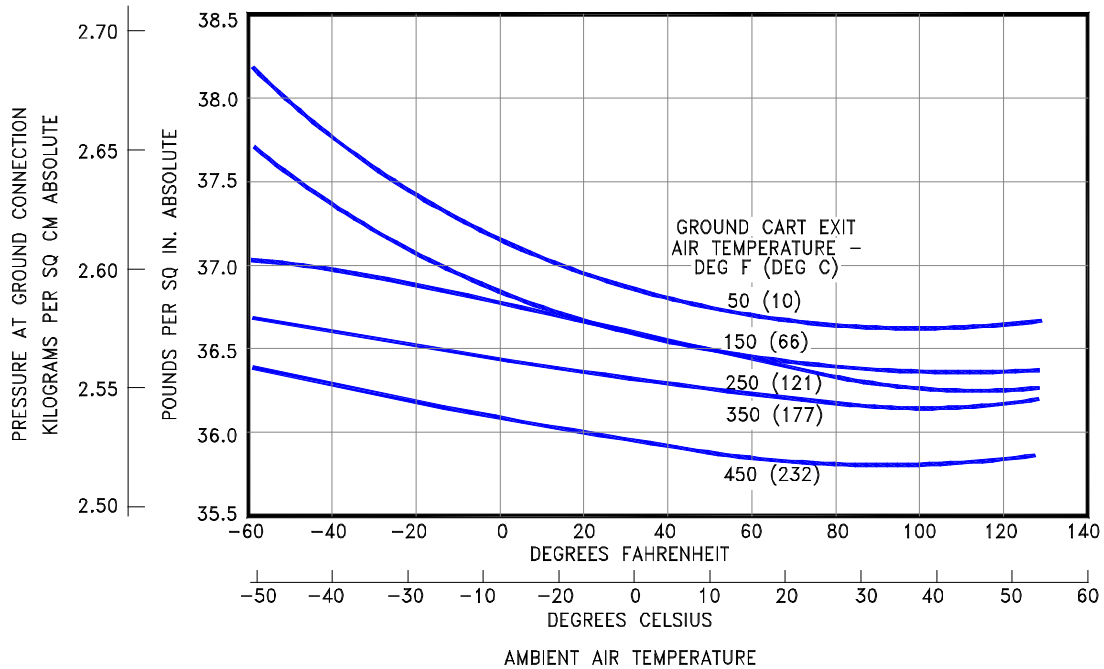
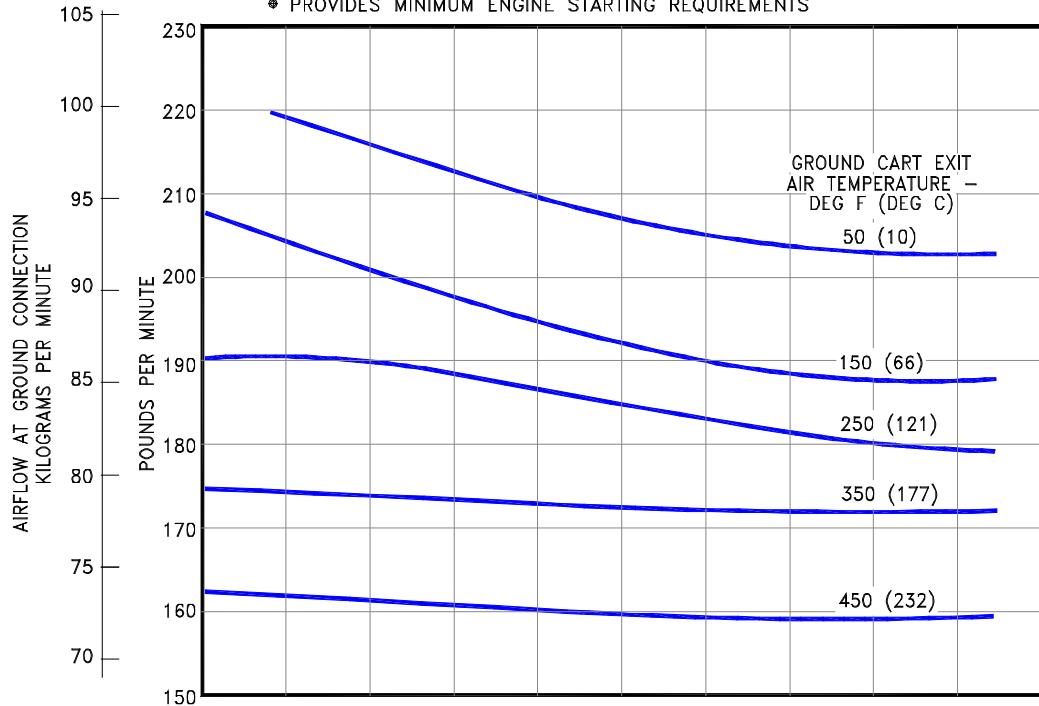

5.5.3 Engine Start Pneumatic Requirements - Sea Level: Model 767-200, -200ER, -300, -300ER, -300 Freighter, -400ER (GE Engines)

NOTES:

- ALTITUDE = SEA LEVEL
- GARRETT STARTER MODEL ATS100-350L
- USE OF TWO GROUND CONNECTIONS IS ASSUMED
- PROVIDES MINIMUM ENGINE STARTING REQUIREMENTS

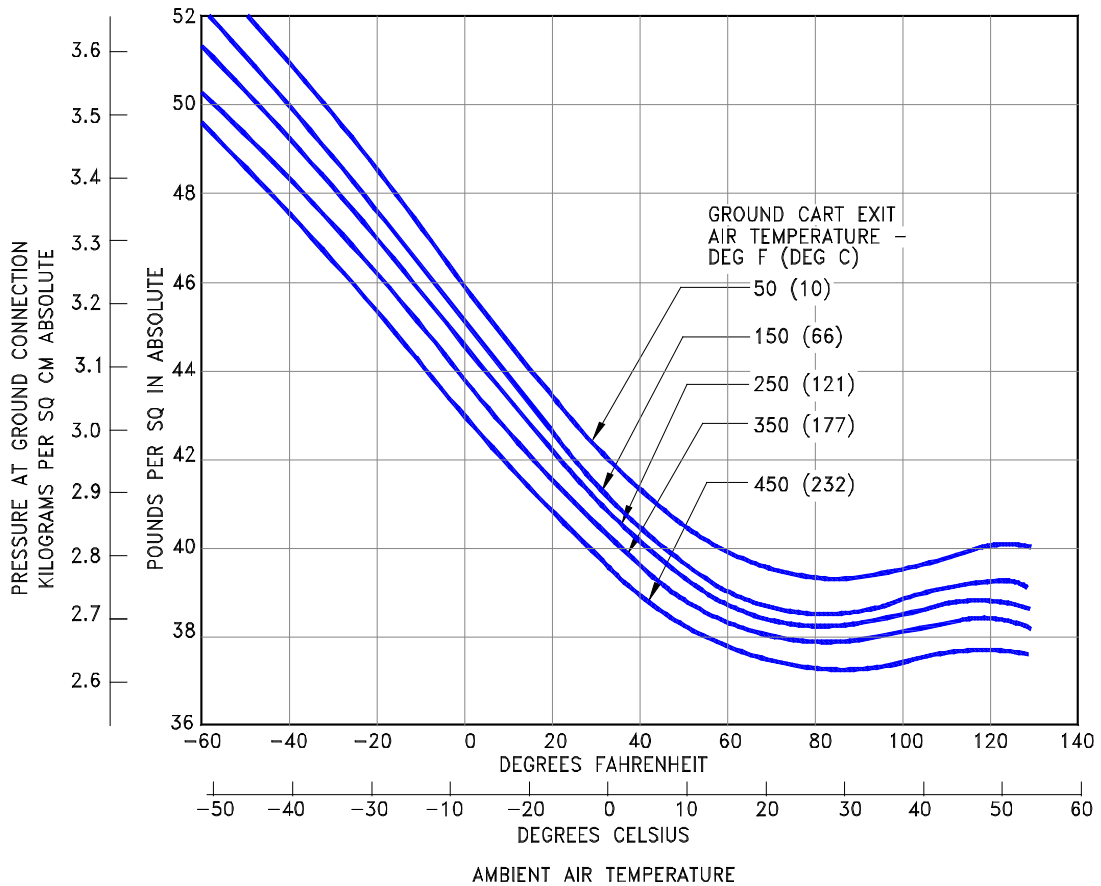
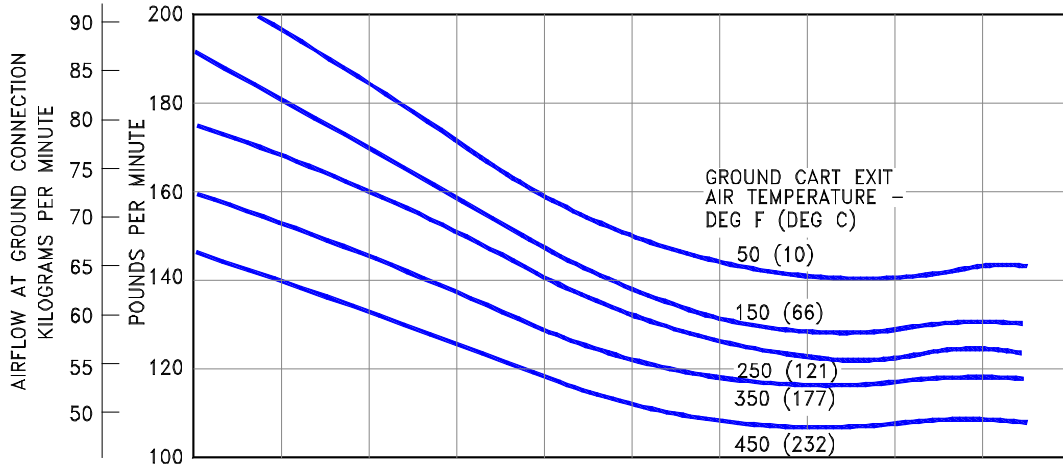

5.5.4 Engine Start Pneumatic Requirements - Sea Level: Model 767-200, -200ER, -300, -300ER, -300 Freighter, -400ER (GE Engines)

- NOTES:
- ALTITUDE = SEA LEVEL
 - HAMILTON STANDARD STARTER MODEL PS600-6
 - USE OF TWO GROUND CONNECTIONS IS ASSUMED
 - PROVIDES MINIMUM ENGINE STARTING REQUIREMENTS

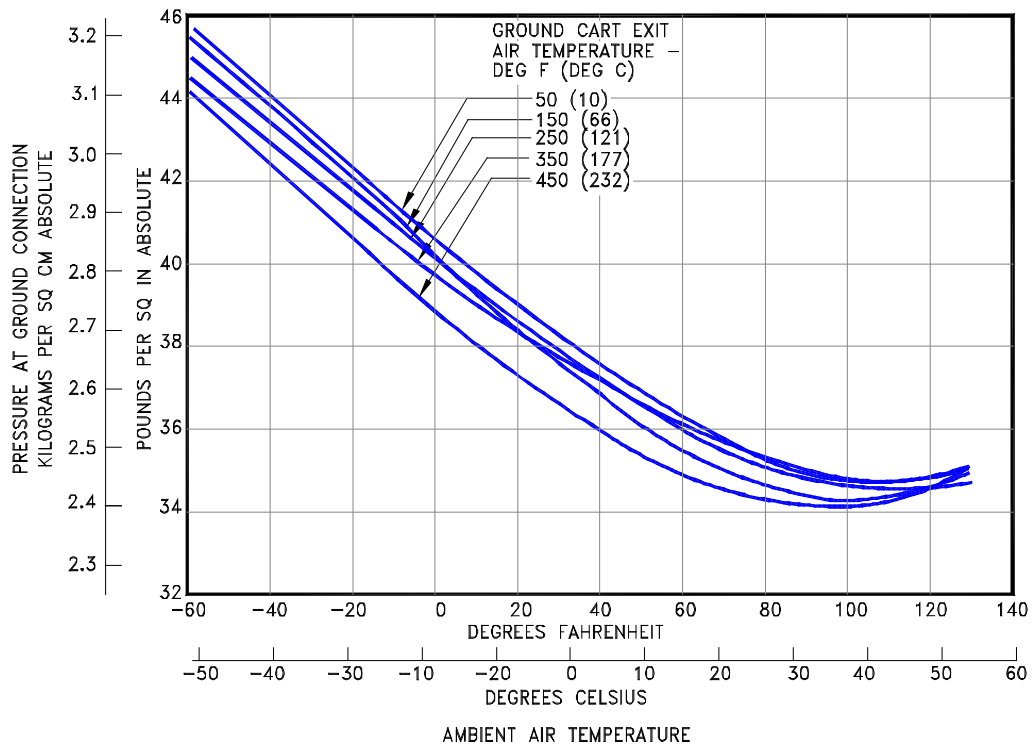
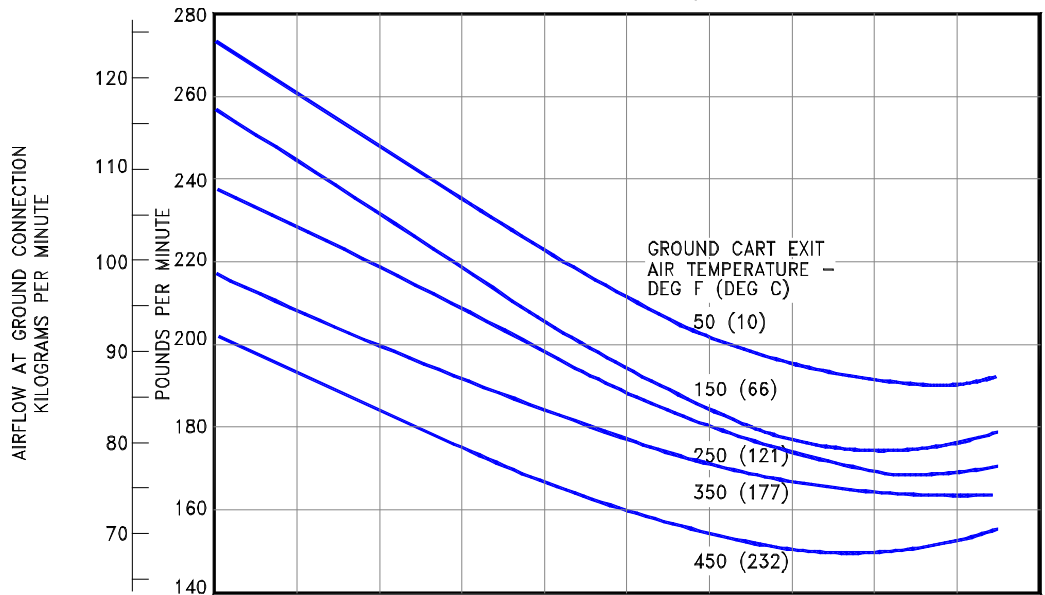

5.5.5 Engine Start Pneumatic Requirements - Sea Level: Model 767-200, -200ER, -300, -300ER, -300 Freighter (Rolls Royce Engines)

- NOTES:
- ALTITUDE = SEA LEVEL
 - HAMILTON STANDARD STARTER MODEL PS600-3
 - USE OF TWO GROUND CONNECTIONS IS ASSUMED
- PROVIDES MINIMUM ENGINE STARTING REQUIREMENTS

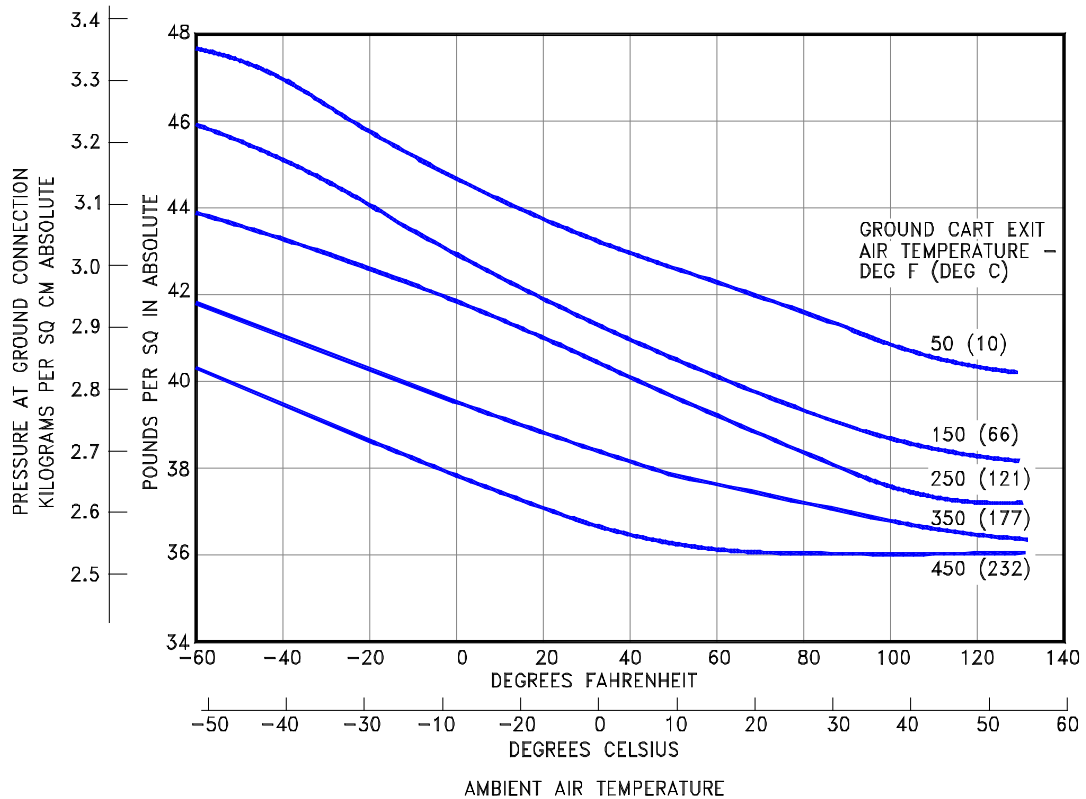
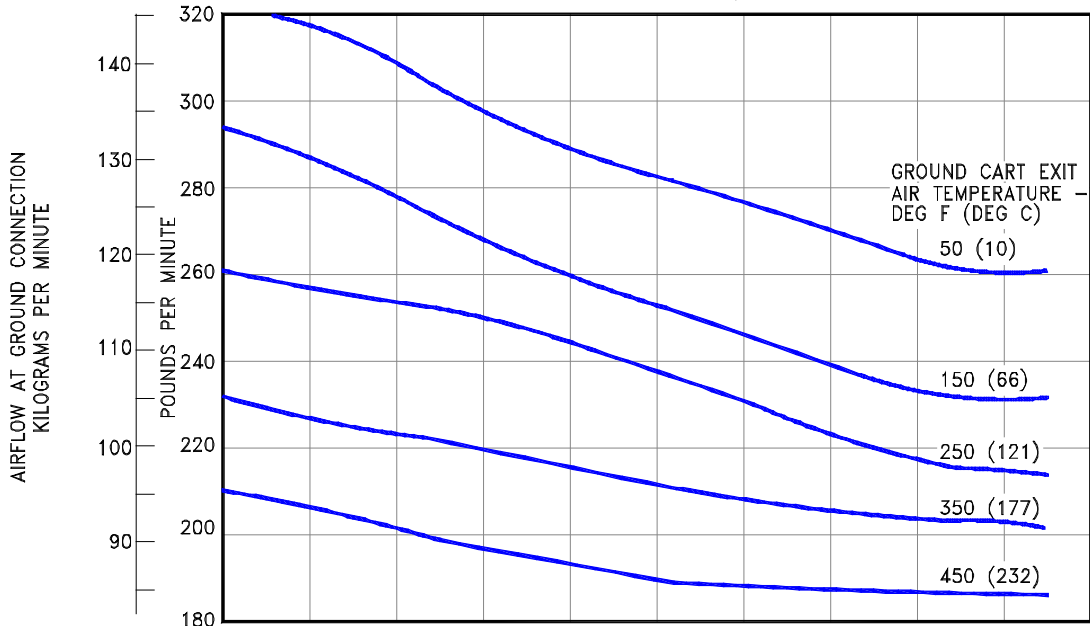

5.6 GROUND PNEUMATIC POWER REQUIREMENTS

5.6.1 Ground Pneumatic Power Requirements - Heating/Cooling: Model 767-200, -200ER

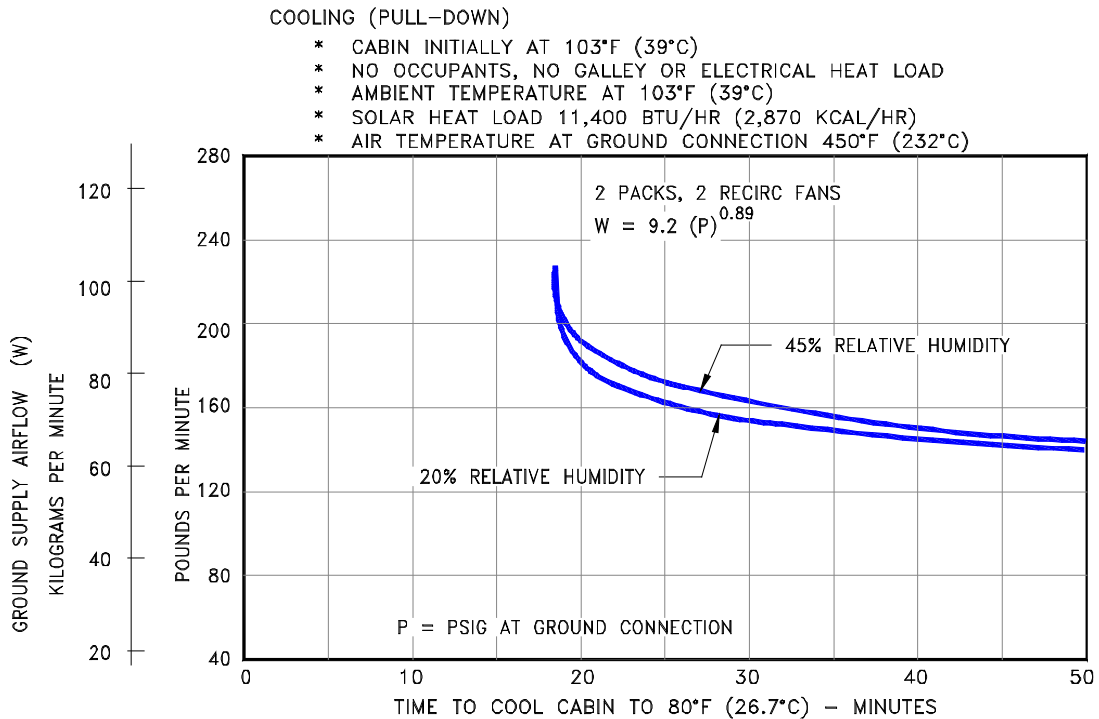
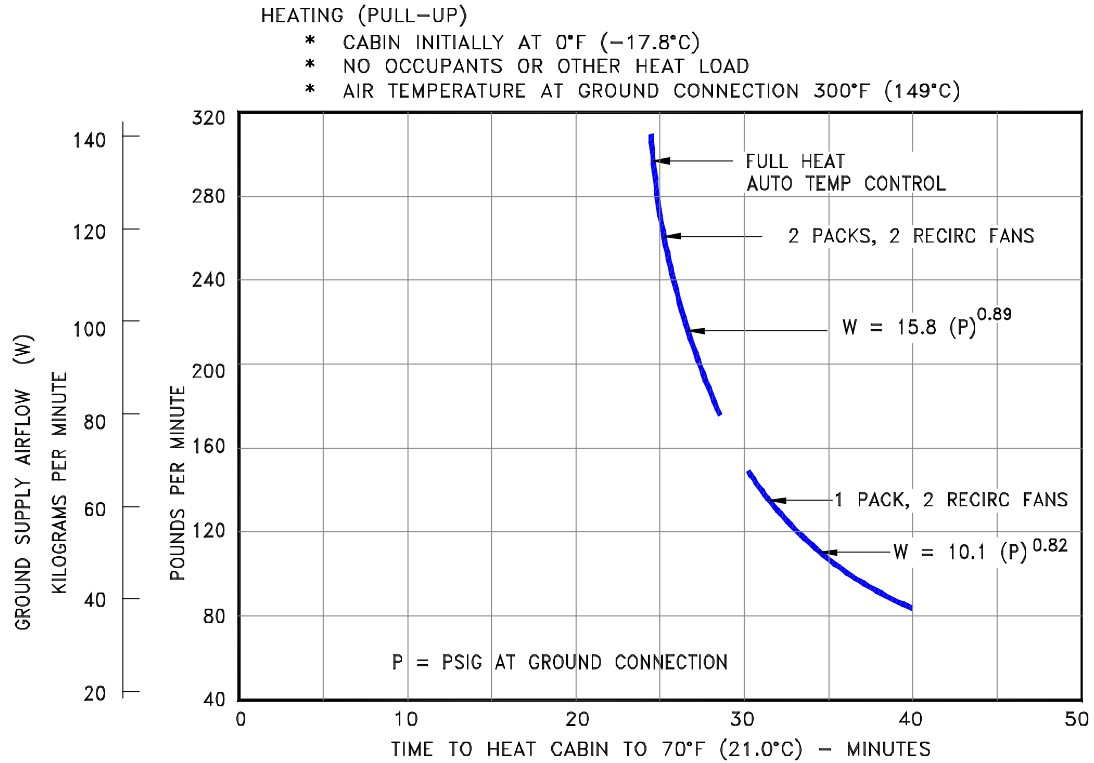

D6-58328

5.6.2 Ground Pneumatic Power Requirements - Heating/Cooling: Model 767-300, -300ER

HEATING (PULL-UP)

- * CABIN INITIALLY AT 0°F (-17.8°C)
- * NO OCCUPANTS OR OTHER HEAT LOAD
- * AIR TEMPERATURE AT GROUND CONNECTION 300°F (149°C)

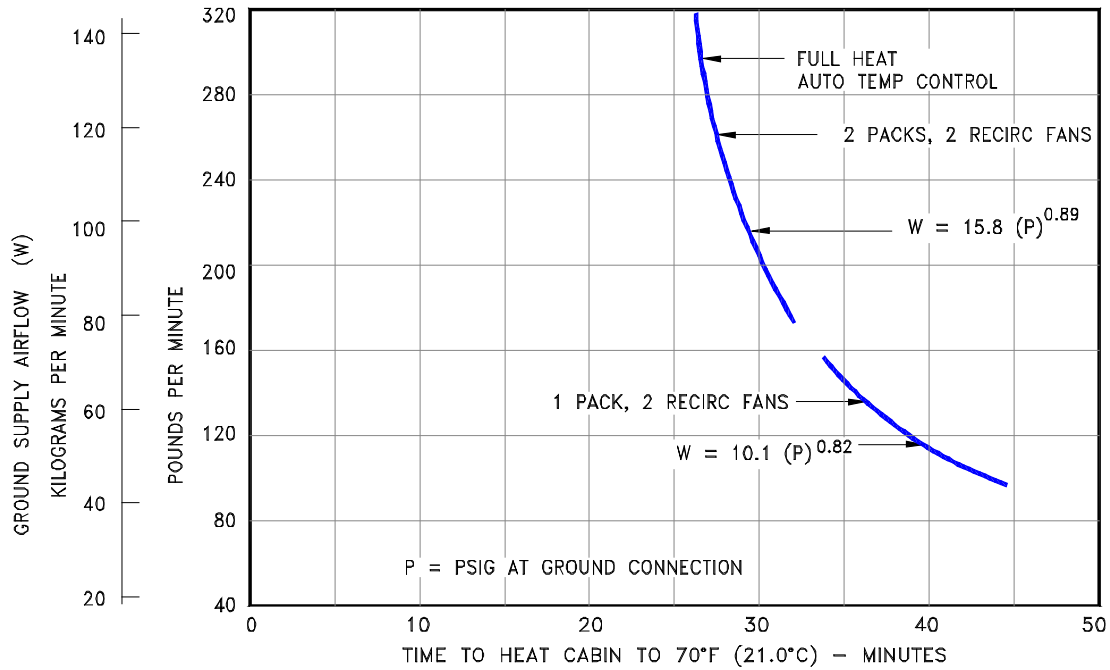

COOLING (PULL-DOWN)

- * CABIN INITIALLY AT 103°F (39°C)
- * NO OCCUPANTS, NO GALLEY OR ELECTRICAL HEAT LOAD
- * AMBIENT TEMPERATURE AT 103°F (39°C)
- * SOLAR HEAT LOAD 11,400 BTU/HR (2,870 KCAL/HR)
- * AIR TEMPERATURE AT GROUND CONNECTION 450°F (232°C)

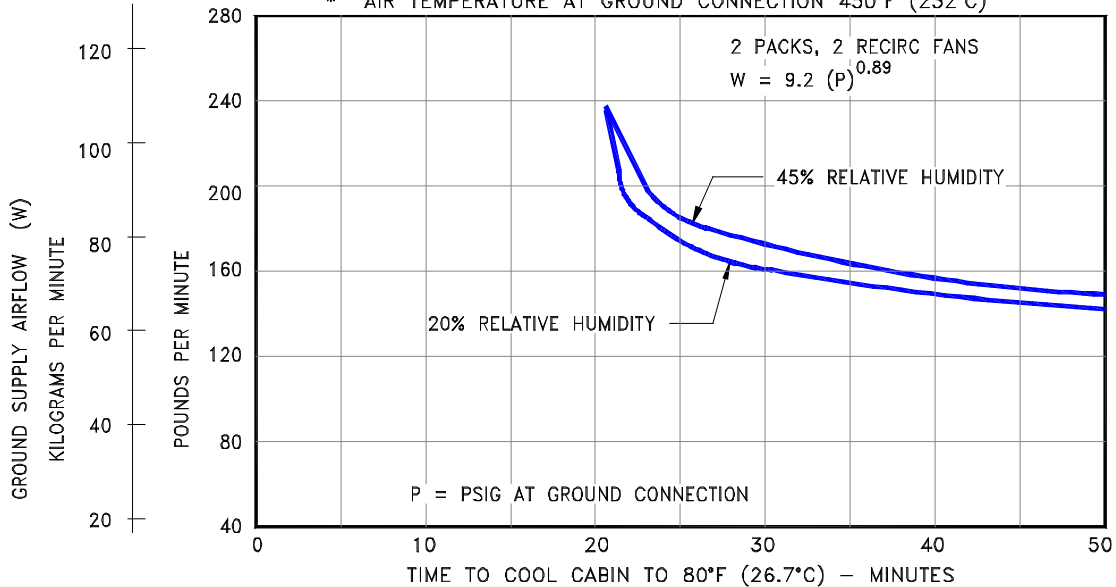

D6-58328

REV I

July 2021

5-29

5.6.3 Ground Pneumatic Power Requirements - Heating/Cooling: Model 767-400ER

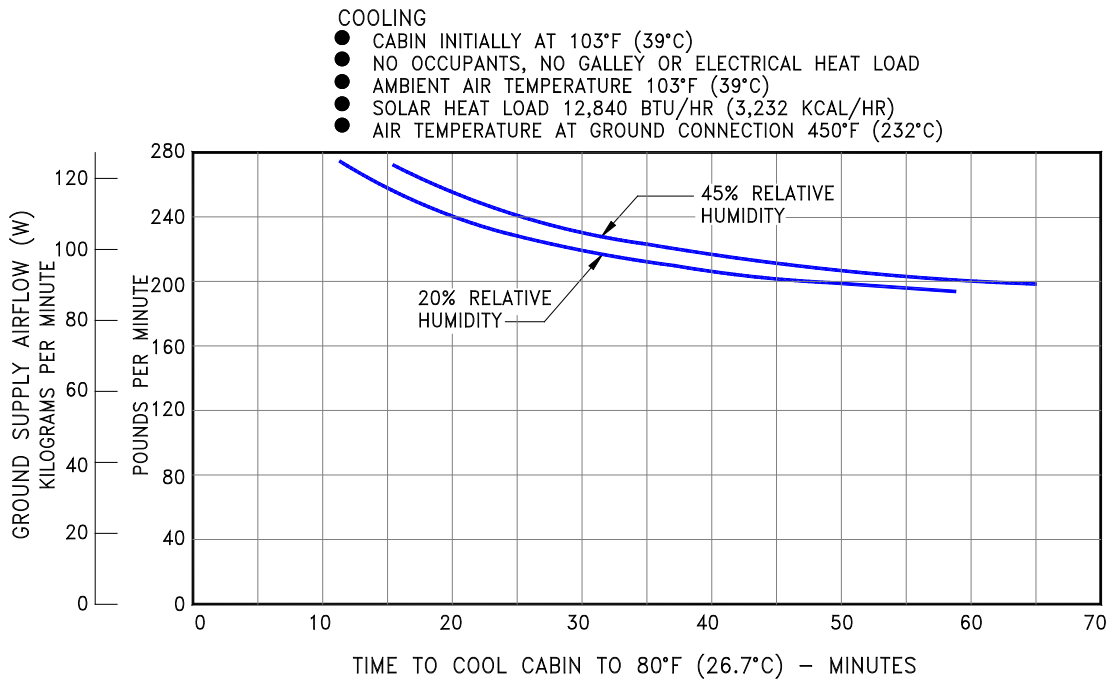
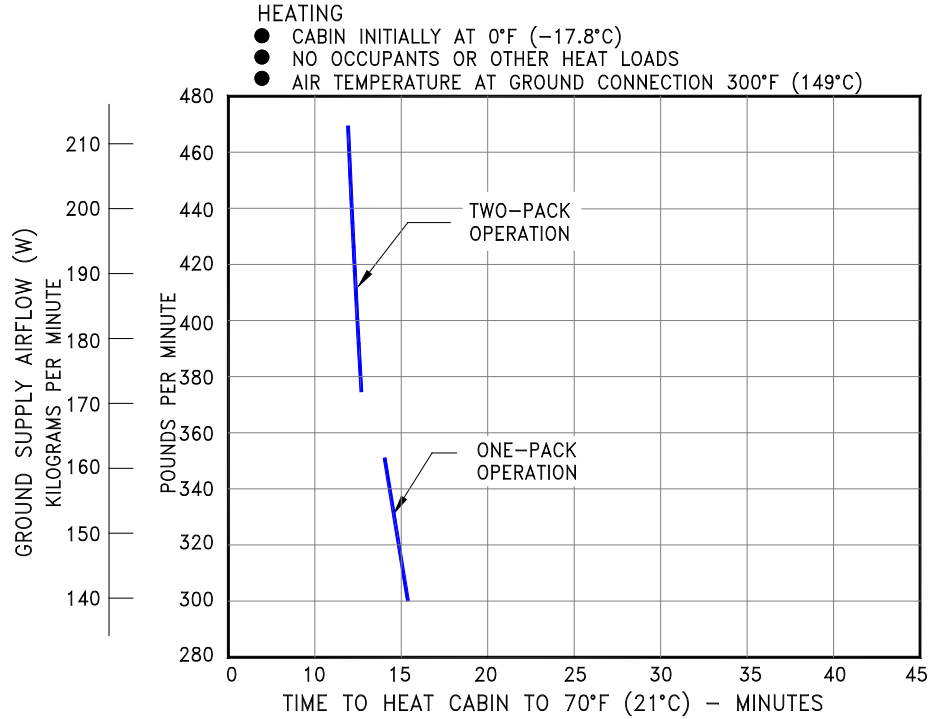

5.7 CONDITIONED AIR REQUIREMENTS

5.7.1 Conditioned Air Flow Requirements – Steady State: Model 767-200, -200ER

CONDITION	AMBIENT TEMPERATURE	SOLAR LOAD	ELECTRICAL LOAD	OCCUPANTS	CABIN TEMPERATURE
①	0°F (-17.8°C)	0	45 BTU/MIN (11.3 KCAL/MIN)	0	75°F (23.9°C)
②	-20°F (-29.0°C)	0		0	75°F (23.9°C)
③④	-40°F (-40.0°C)	0		0	75°F (23.9°C)
⑤⑥	103°F (39.0°C)	169.5 BTU/MIN (42.7 KCAL/MIN)	637 BTU/MIN (160.5 KCAL/MIN)	216	75°F (23.9°C)
⑦	103°F (39.0°C)			216	80°F (26.7°C)

NOTE: ALL DOORS AND HATCHES CLOSED ON ALL CONDITIONS

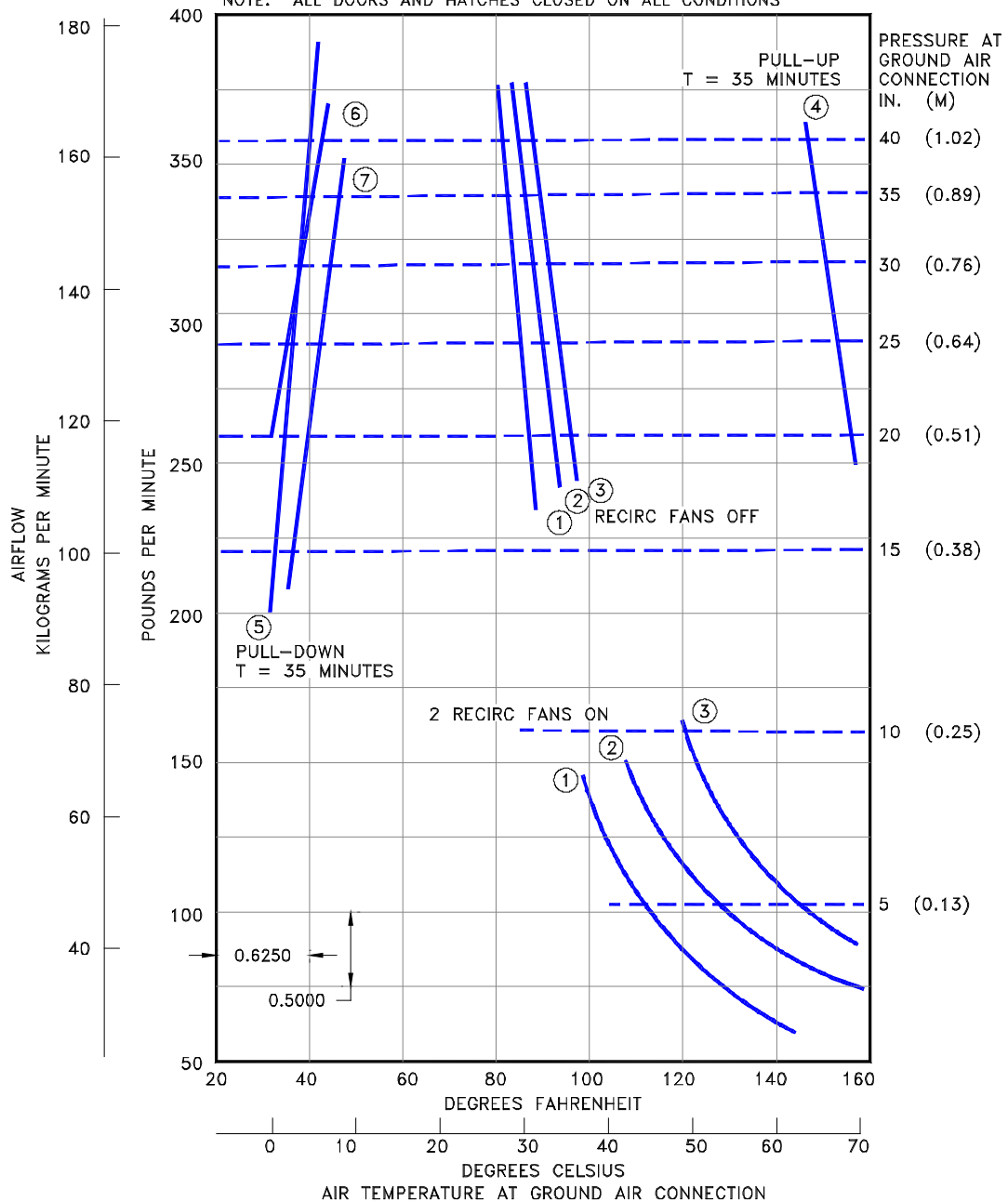

D6-58328

REV I

July 2021

5-31

5.7.2 Conditioned Air Flow Requirements – Steady State: Model 767-300, -300ER, -300 Freighter

CONDITION	AMBIENT TEMPERATURE	SOLAR LOAD	ELECTRICAL LOAD	OCCUPANTS	CABIN TEMPERATURE
①	0°F (-17.8°C)	0	45 BTU/MIN (11.3 KCAL/MIN)	0	75°F (23.9°C)
②	-20°F (-29.0°C)	0		0	75°F (23.9°C)
③ ④	-40°F (-40.0°C)	0		0	75°F (23.9°C)
⑤ ⑥	103°F (39.0°C)	214 BTU/MIN (53.9 KCAL/MIN)	803 BTU/MIN (201.5 KCAL/MIN)	268	75°F (23.9°C)
⑦	103°F (39.0°C)			268	80°F (26.7°C)

NOTE: ALL DOORS AND HATCHES CLOSED ON ALL CONDITIONS

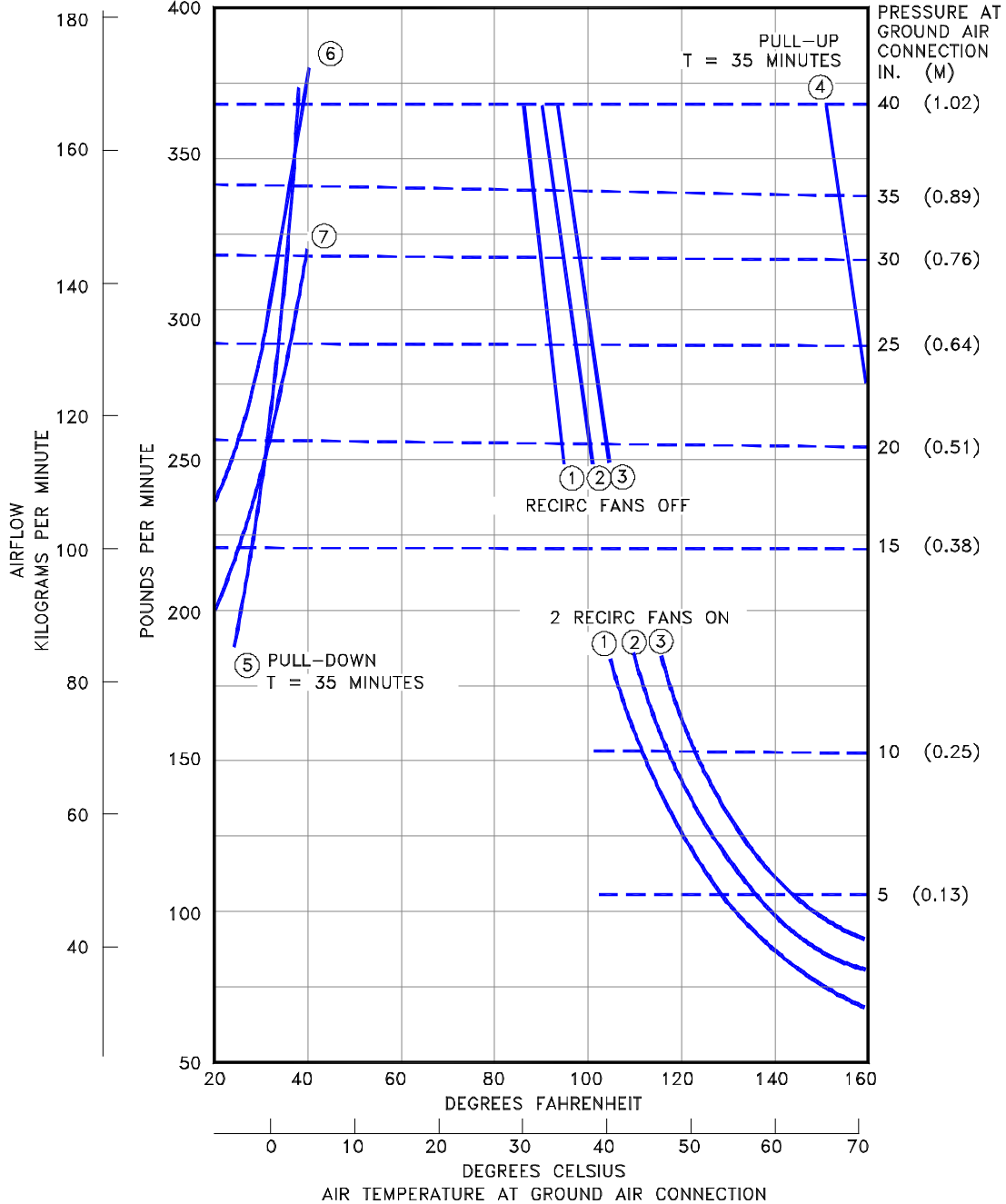

D6-58328

REV I

July 2021

5-32

5.7.3 Conditioned Air Flow Requirements – Steady State: Model 767-400ER

COOLING (1), (2)

- ALL EXTERIOR DOOR AND WINDOWS CLOSED
- OUTSIDE TEMPERATURE 103°F (39°C)
- FULL SOLAR AND ELECTRICAL HEAT LOADS
- RECIRCULATION FANS OFF
- CHILLERS ON
- 216 OCCUPANTS
- CABIN TEMPERATURE MAINTAINED AT 75°F (24°C)
- ① IFE ON
- ② IFE OFF

HEATING (3)

- ALL EXTERIOR DOORS AND WINDOWS CLOSED
- OUTSIDE TEMPERATURE -40°F (-40°C)
- NO SOLAR OR ELECTRICAL HEAT LOADS
- RECIRCULATION FANS OFF
- CHILLERS OFF
- NO OCCUPANTS
- CABIN TEMPERATURE MAINTAINED AT 75°F (24°C)

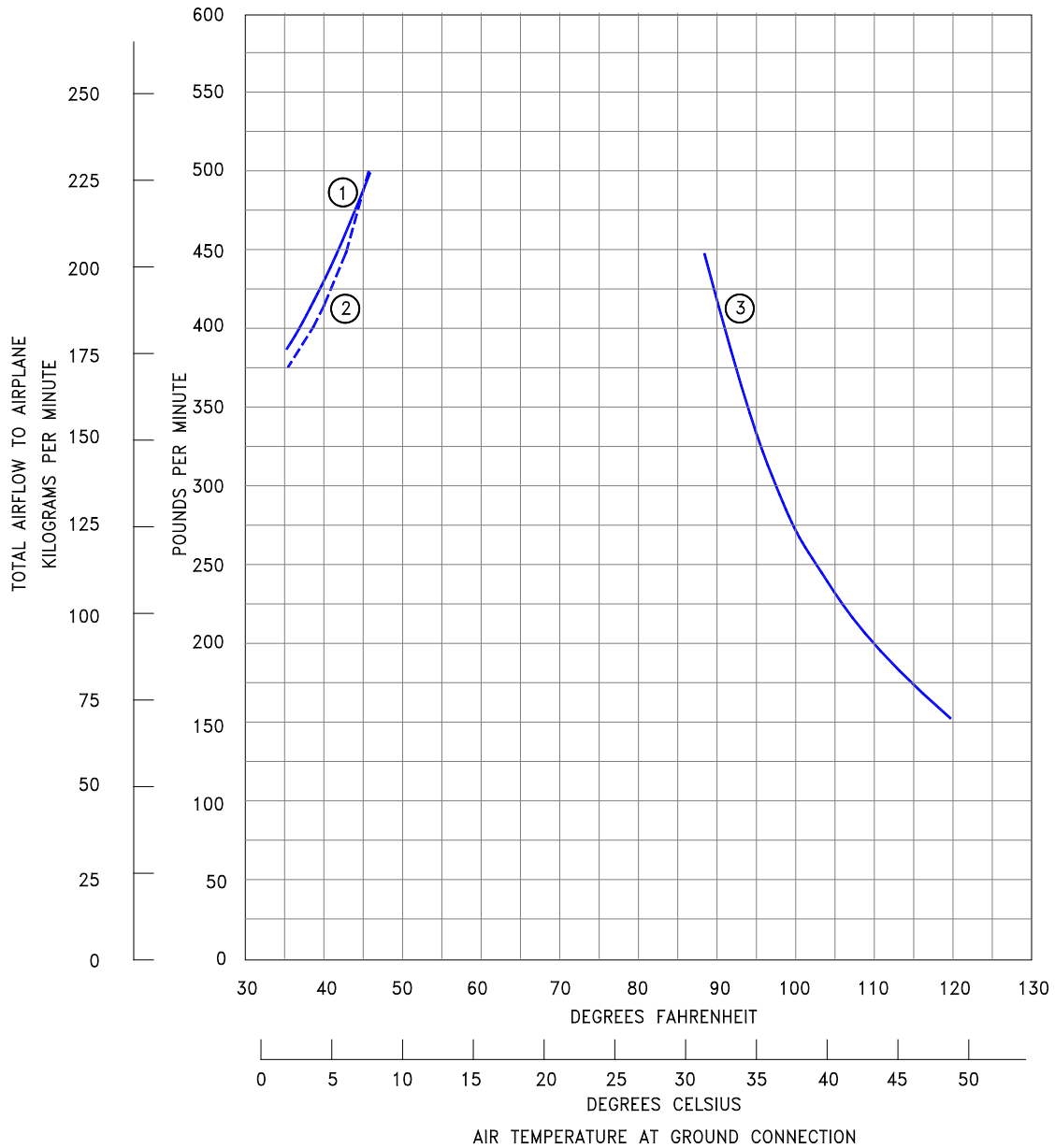

5.7.4 Conditioned Air Flow Pressure Requirements: Model 767-400ER

NOTE:
 THE GRAPH ON THIS PAGE SHOWS THE STATIC PRESSURE GAGE AT THE CONNECTOR AS A FUNCTION OF AIRFLOW. THIS GRAPH IS USED IN CONJUNCTION WITH THE GRAPH IN SECTION 5.7.1 TO DETERMINE THE AIRFLOW AND PRESSURE REQUIREMENTS WHEN USING A CONDITIONED AIR GROUND SOURCE.

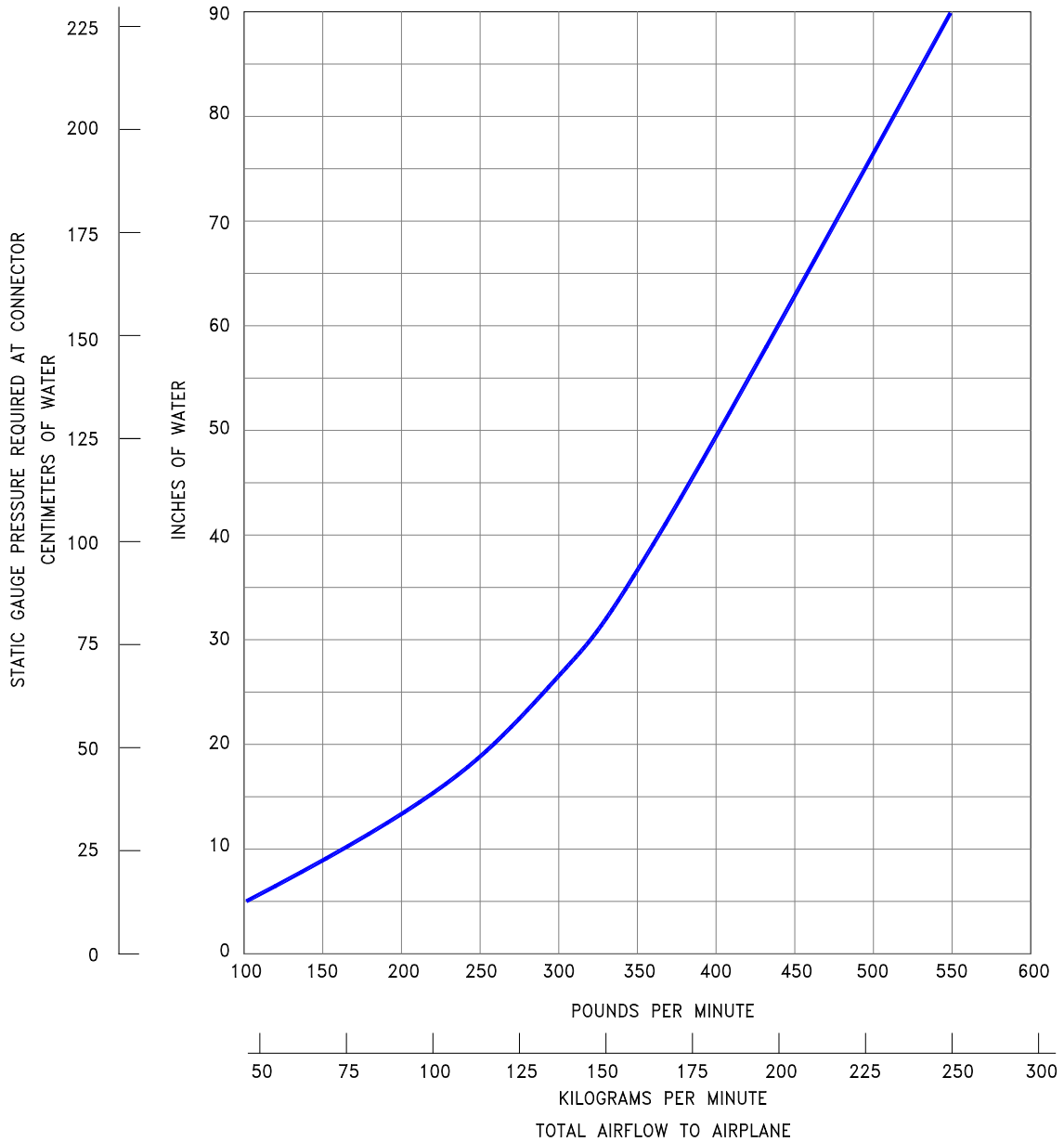

5.8 GROUND TOWING REQUIREMENTS

5.8.1 Ground Towing Requirements - English Units: Model 767-200, -200ER, -300, -300ER, -300 Freighter, -400ER

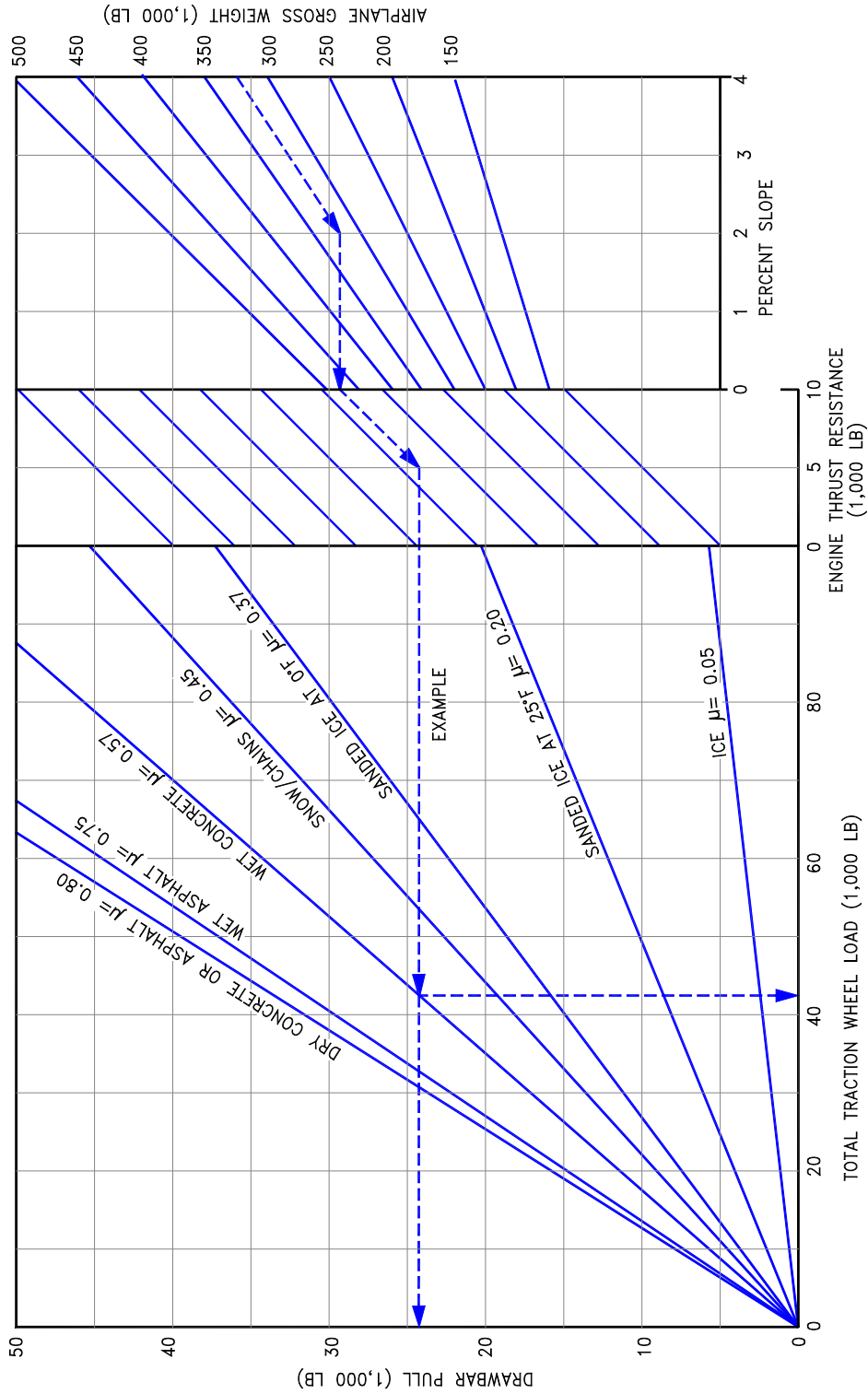

EXAMPLE: A 767-300ER WEIGHING 325,000 LB BEING PUSHED UP A 2% SLOPE ON WET CONCRETE AGAINST TWO ENGINES AT IDLE THRUST (APPROX 5,000 LB OF THRUST) WILL REQUIRE APPROX 24,300 LB OF DRAWBAR PUSH AND A WHEEL TRACTION LOAD OF APPROX 42,700 LB

- NOTES:
1. STRAIGHT-LINE TOW
 2. UNUSUAL BREAKAWAY CONDITIONS NOT SHOWN
 3. COEFFICIENTS OF FRICTION (μ) ARE ESTIMATED FOR RUBBER-TIRED TOW VEHICLES

D6-58328

REV I

July 2021

5-35

5.8.2 Ground Towing Requirements - Metric Units: Model 767-200, -200ER, -300, -300ER, -300 Freighter, -400ER

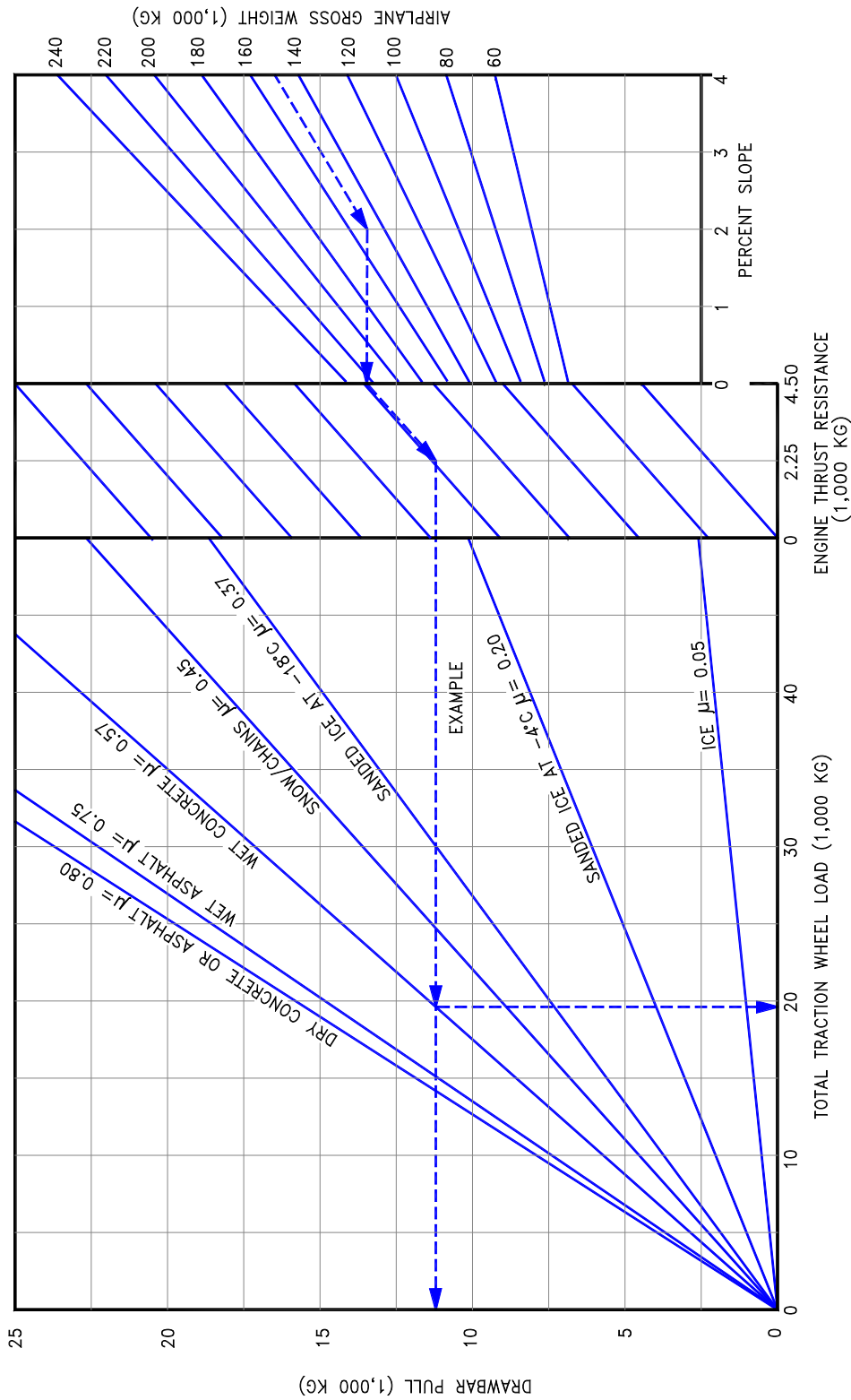

EXAMPLE: A 767-300ER WEIGHING 150,000 KG BEING PUSHED UP
 A 2% SLOPE ON WET CONCRETE AGAINST TWO ENGINES
 AT IDLE THRUST (APPROX ,2250 KG OF THRUST) WILL
 REQUIRE APPROX 11,200 KG OF DRAWBAR PUSH AND A
 WHEEL TRACTION LOAD OF APPROX 19,750 KG

- NOTES:
1. STRAIGHT-LINE TOW
 2. UNUSUAL BREAKAWAY CONDITIONS NOT SHOWN
 3. COEFFICIENTS OF FRICTION (μ) ARE ESTIMATED FOR RUBBER-TIRED TOW VEHICLES

6.0 JET ENGINE WAKE AND NOISE DATA

6.1 JET ENGINE EXHAUST VELOCITIES AND TEMPERATURES

This section shows exhaust velocity and temperature contours aft of the 767-200, -300, -400ER airplane. The contours were calculated from a standard computer analysis using three-dimensional viscous flow equations with mixing of primary, fan, and free-stream flow. The presence of the ground plane is included in the calculations as well as engine tilt and toe-in. Mixing of flows from the engines is also calculated. The analysis does not include thermal buoyancy effects which tend to elevate the jet wake above the ground plane. The buoyancy effects are considered to be small relative to the exhaust velocity and therefore are not included.

The graphs show jet wake velocity and temperature contours for representative engines. The results are valid for sea level, static, standard day conditions. The effect of wind on jet wakes is not included. There is evidence to show that a downwind or an upwind component does not simply add or subtract from the jet wake velocity, but rather carries the whole envelope in the direction of the wind. Crosswinds may carry the jet wake contour far to the side at large distances behind the airplane.

6.1.1 Jet Engine Exhaust Velocity Contours – Idle Thrust: Model 767-200, -200ER, -300 (JT9D-7R4D, -7R4E Engines)

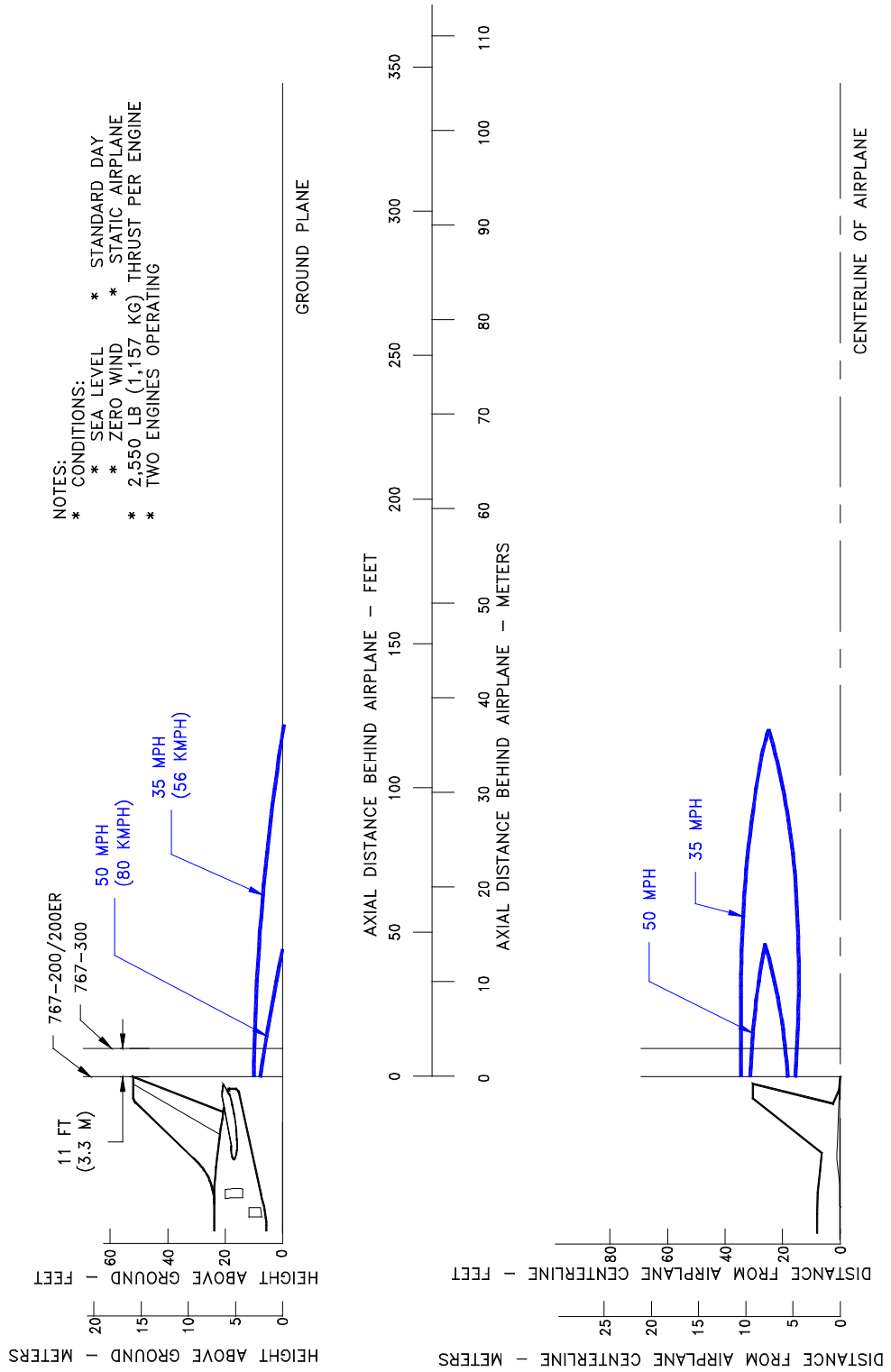

D6-58328

6.1.2 Jet Engine Exhaust Velocity Contours – Idle Thrust: Model 767-200, -200ER, -300 (CF6-80A, -80A2 Engines)

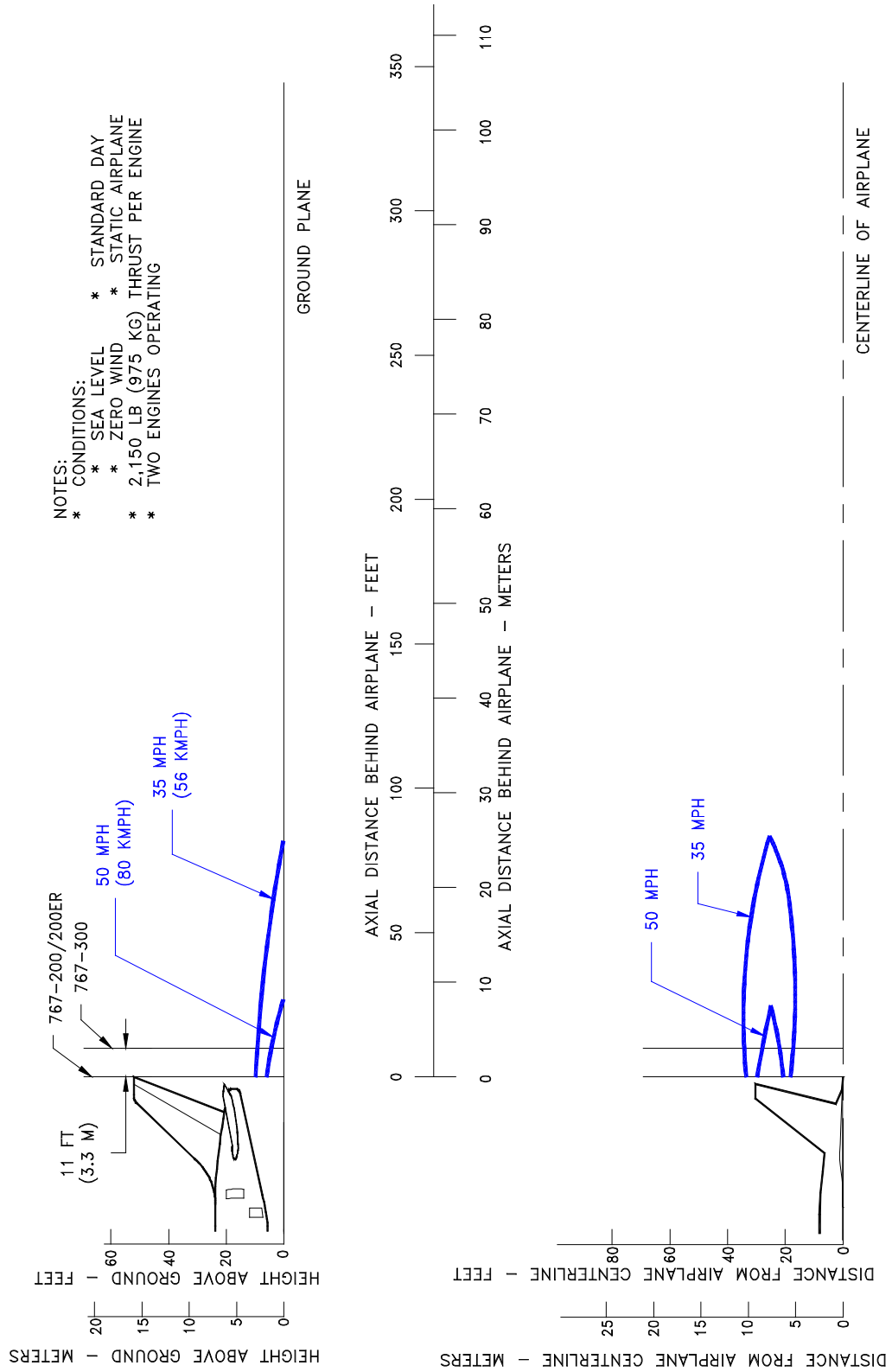

6.1.3 Jet Engine Exhaust Velocity Contours – Idle Thrust: Model 767-300, -300ER, -300 Freighter (PW4000, CF6-80C2 Series Engines)

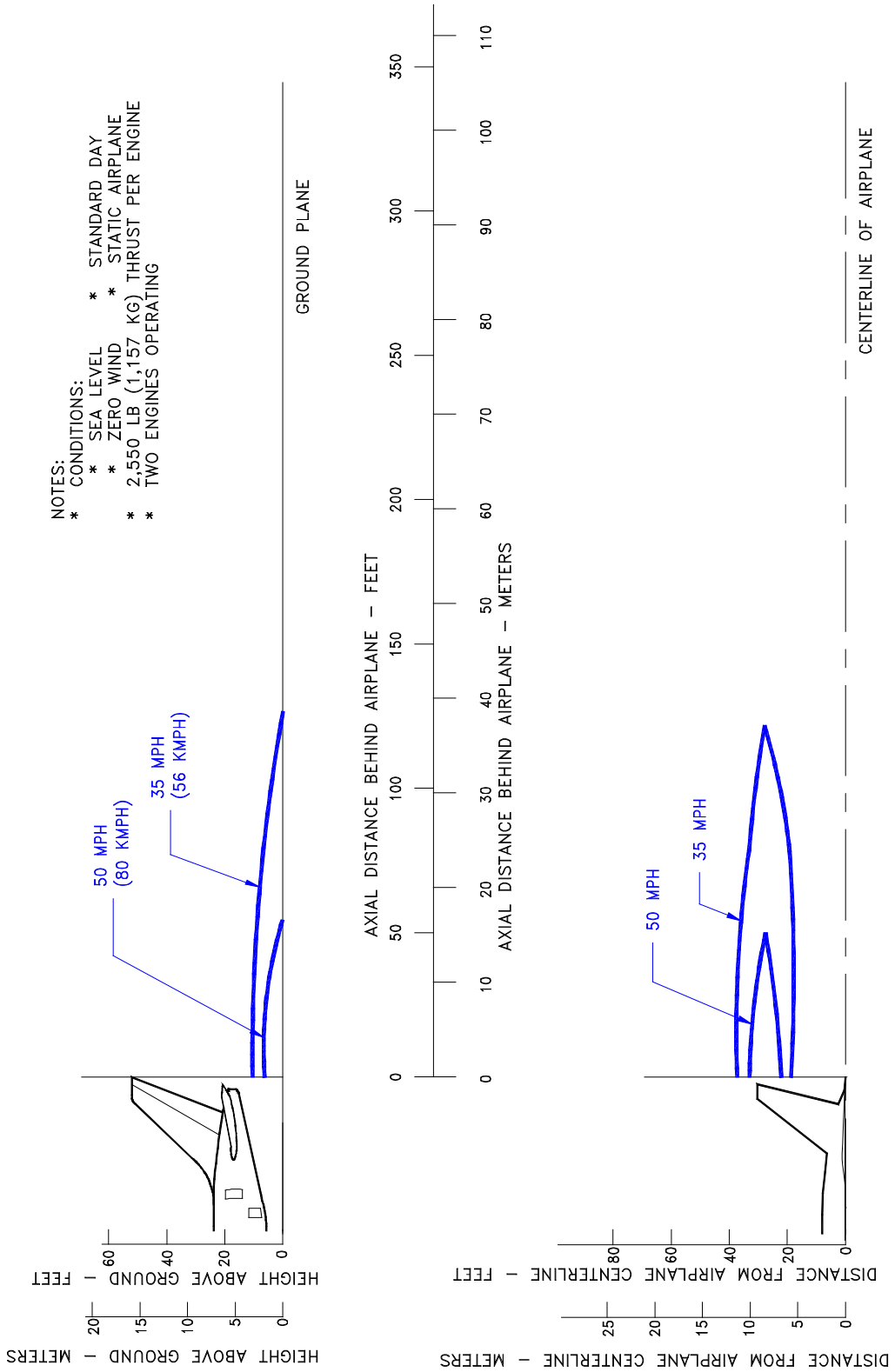

6.1.4 Jet Engine Exhaust Velocity Contours – Idle Thrust: Model 767-300, -300ER, -300 Freighter (RB211-524 Engines)

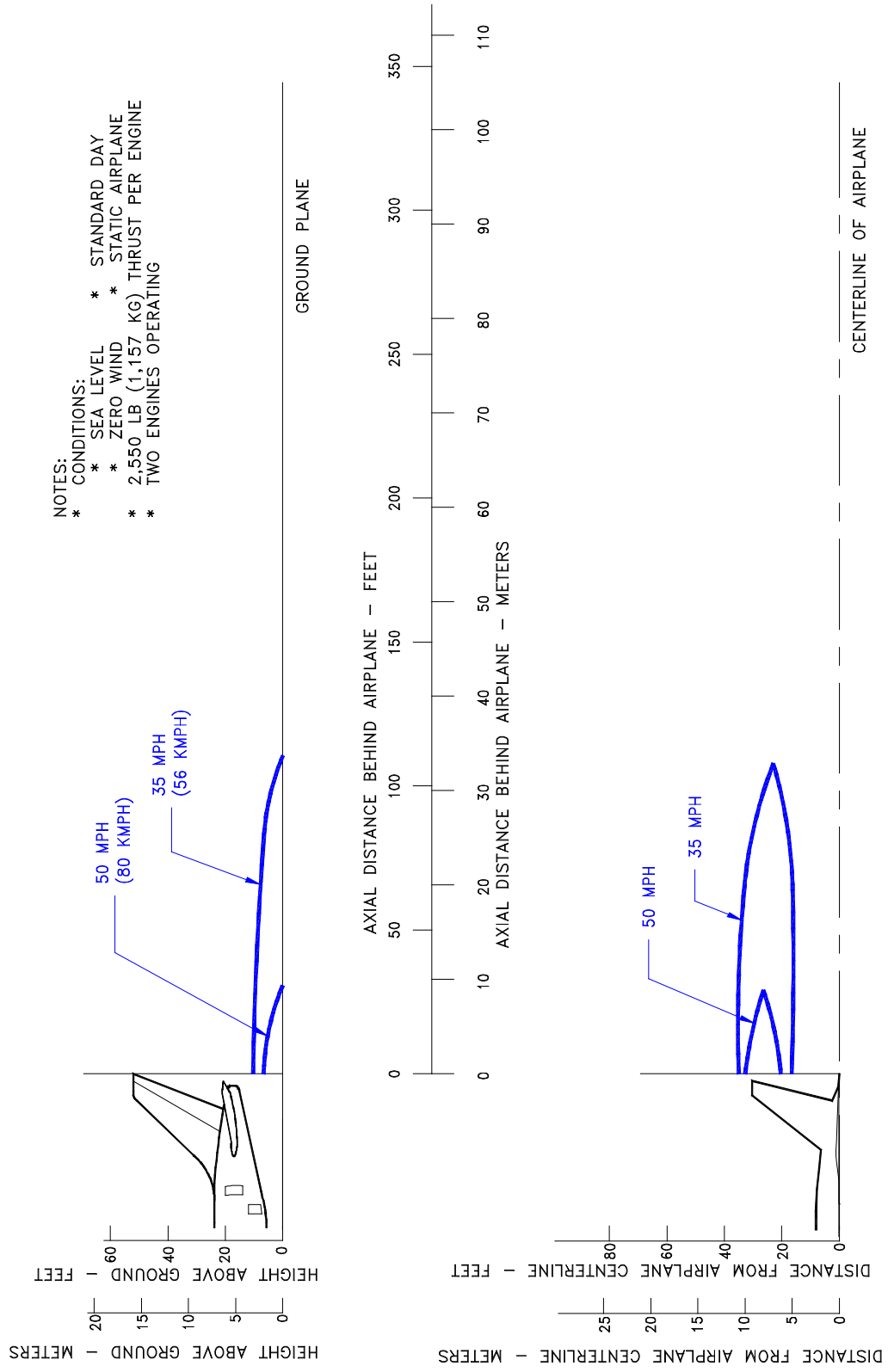

6.1.5 Jet Engine Exhaust Velocity Contours – Idle Thrust: Model 767-400ER (All Engines)

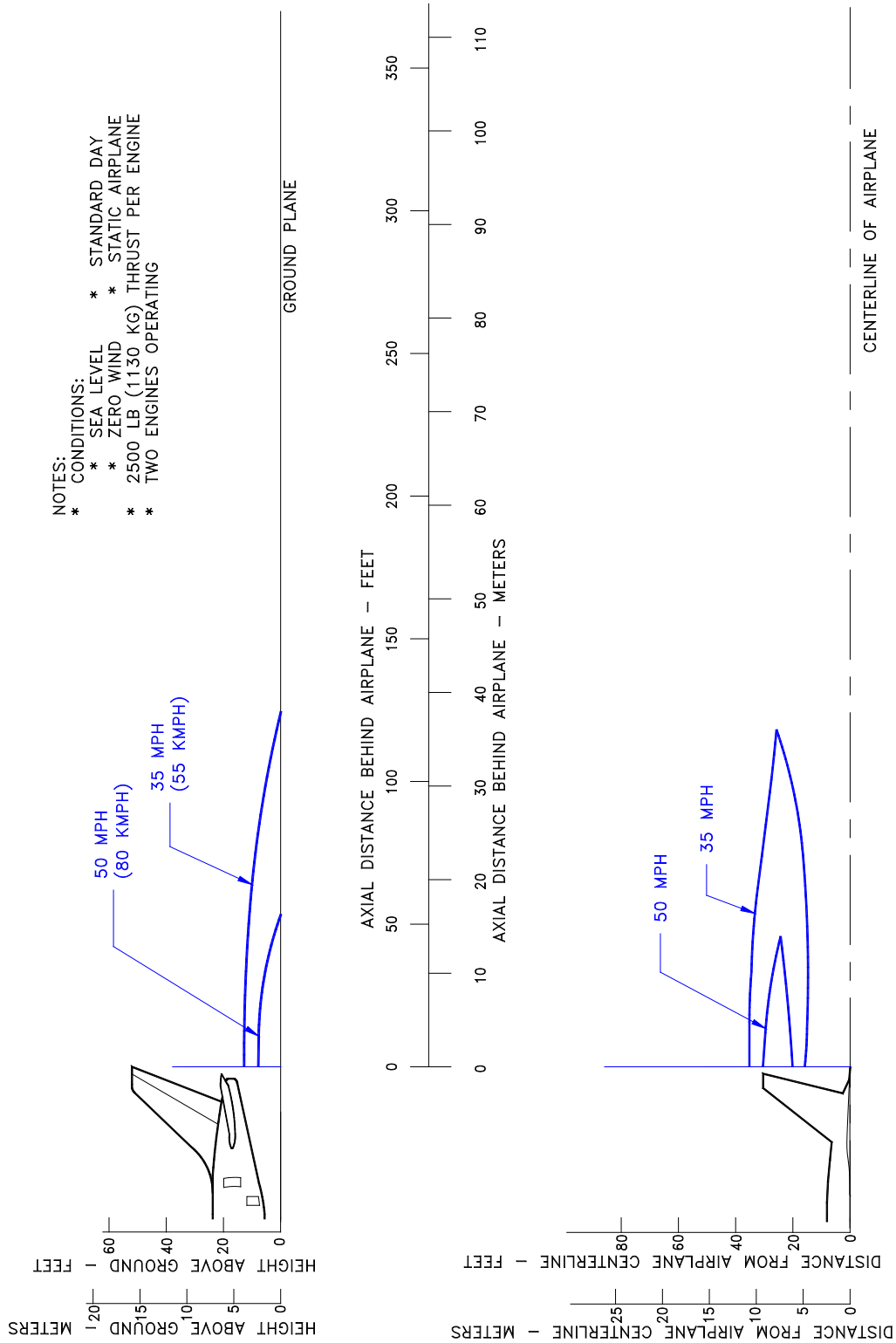

6.1.6 Jet Engine Exhaust Velocity Contours – Low Breakaway Thrust: Model 767-200, -200ER, -300 (JT9D-7R4D, -7R4E Engines)

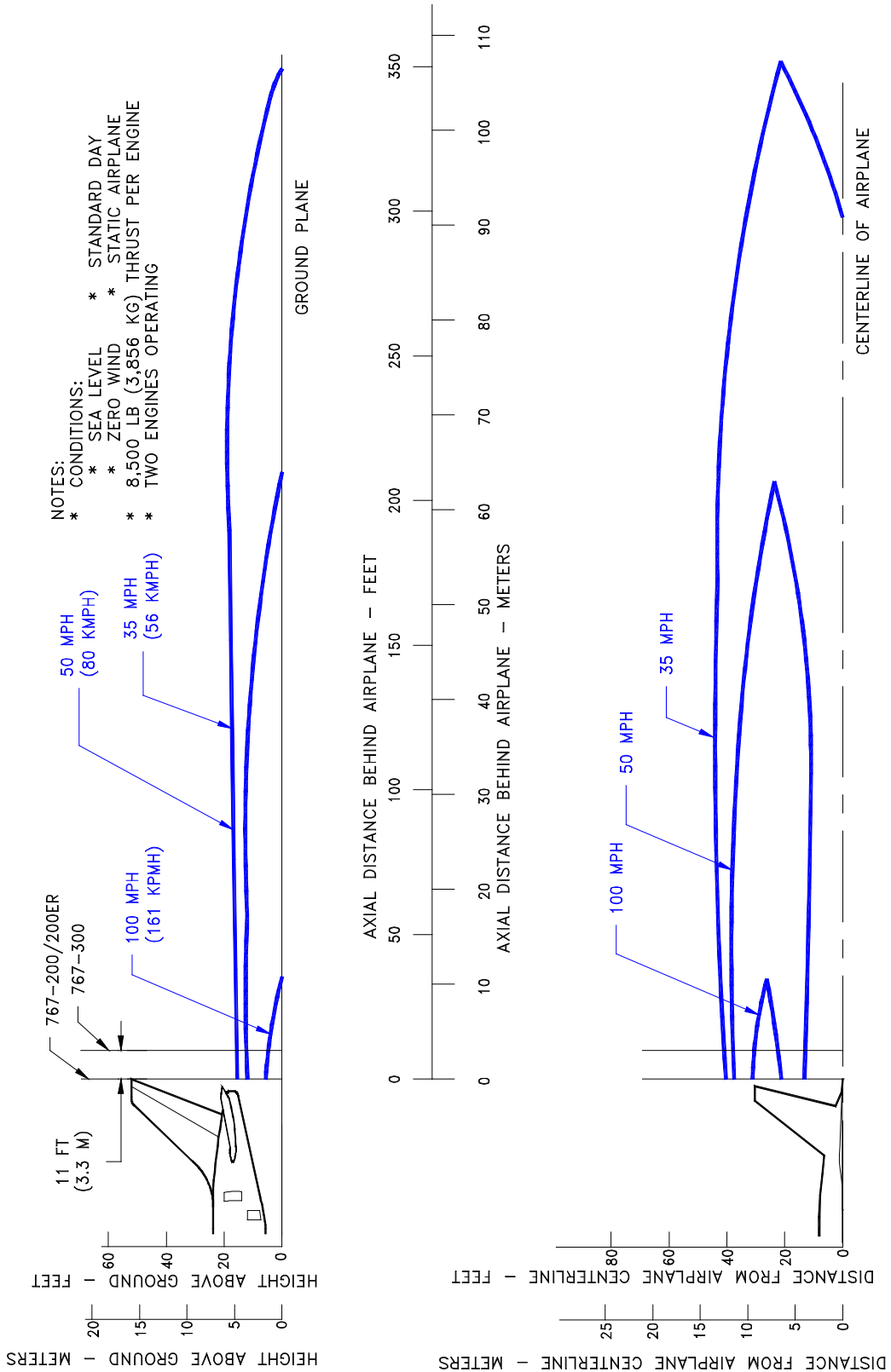

D6-58328

6.1.7 Jet Engine Exhaust Velocity Contours – Low Breakaway Thrust: Model 767-200, -200ER, -300 (CF6-80A, -80A2 Engines)

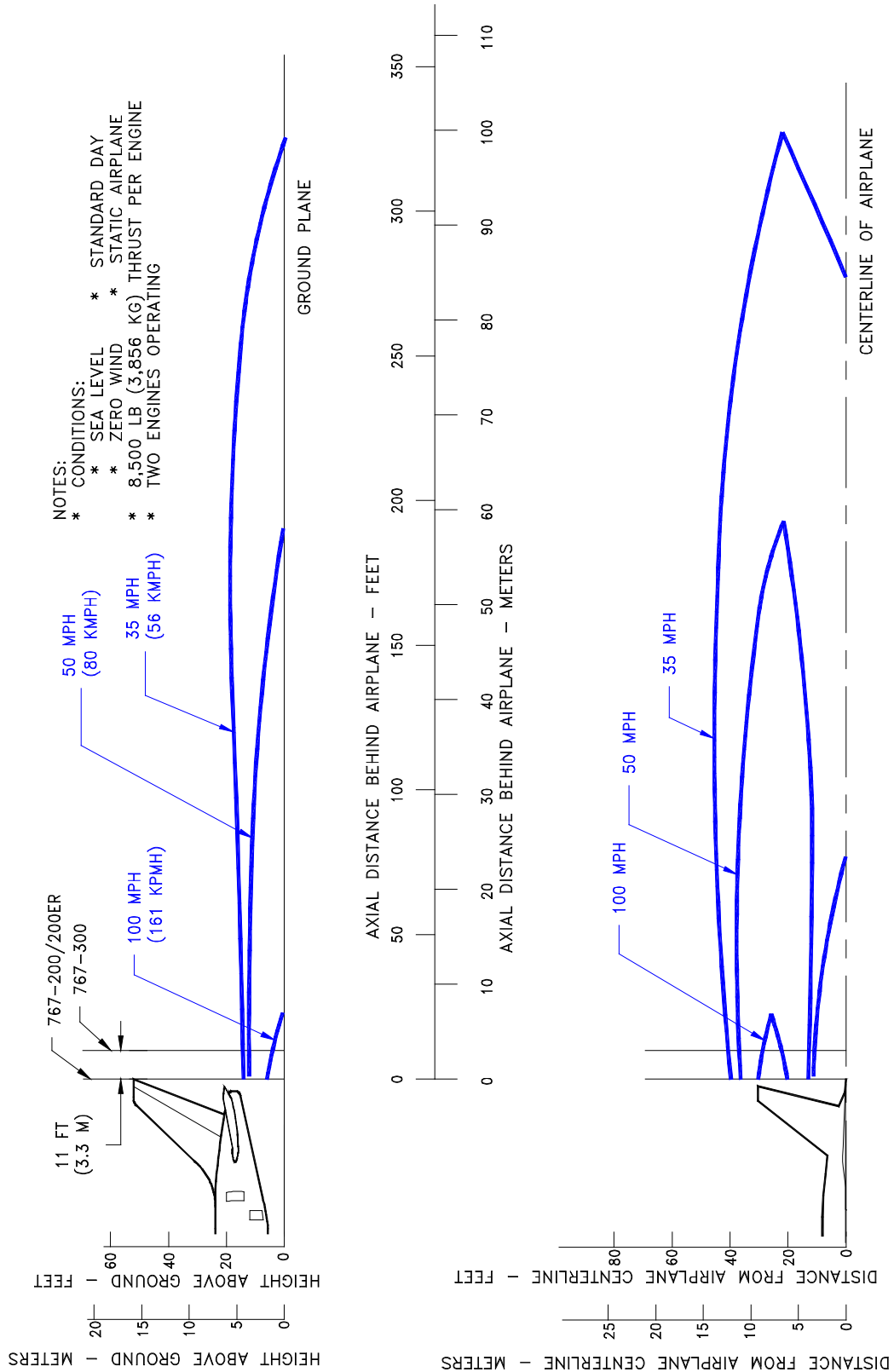

6.1.8 Jet Engine Exhaust Velocity Contours – Low Breakaway Thrust: Model 767-400ER (All Engines)

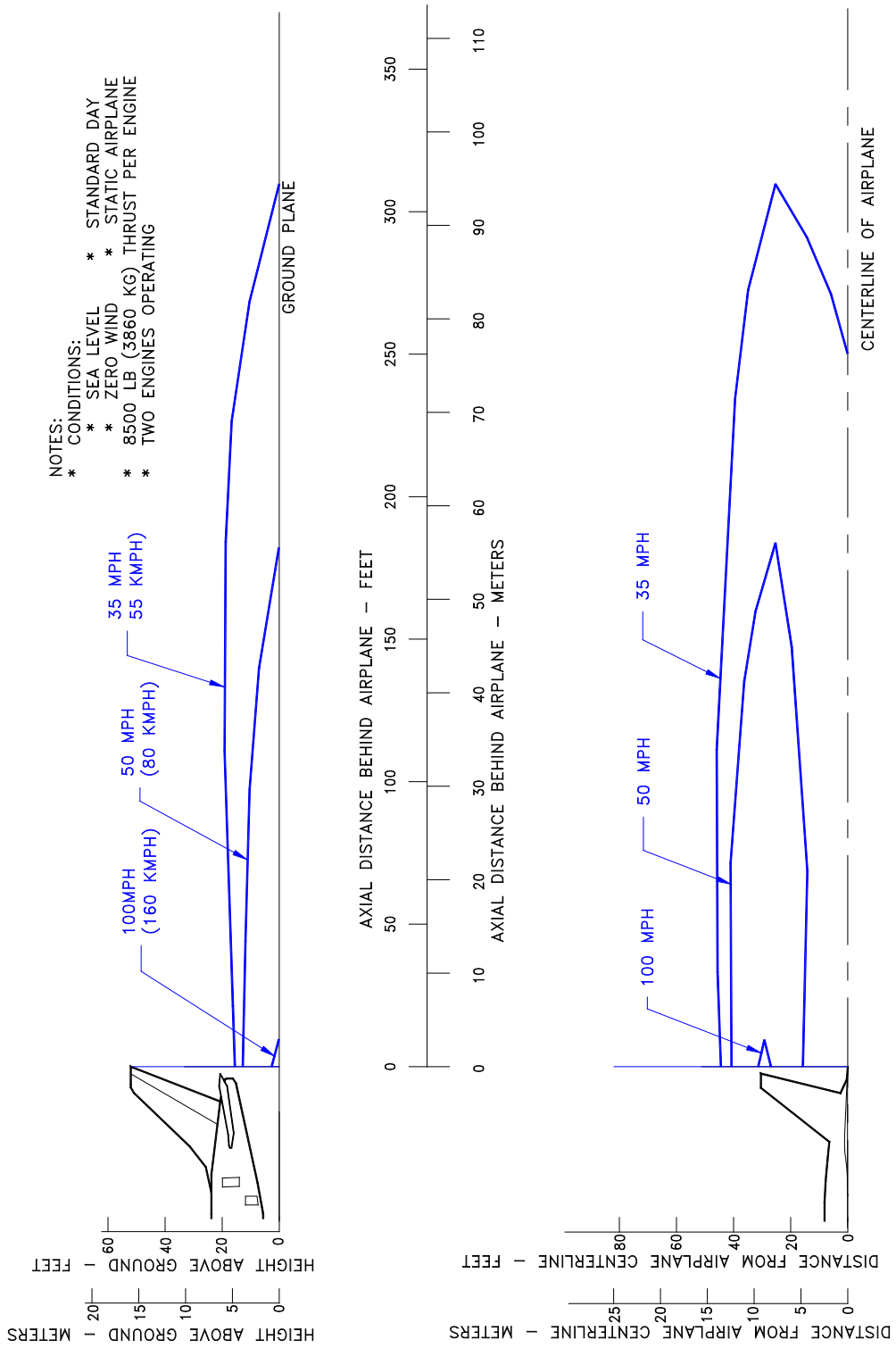

6.1.9 Jet Engine Exhaust Velocity Contours – High Breakaway Thrust: Model 767-200, -200ER, -300, -300ER, -300 Freighter (All Engines)

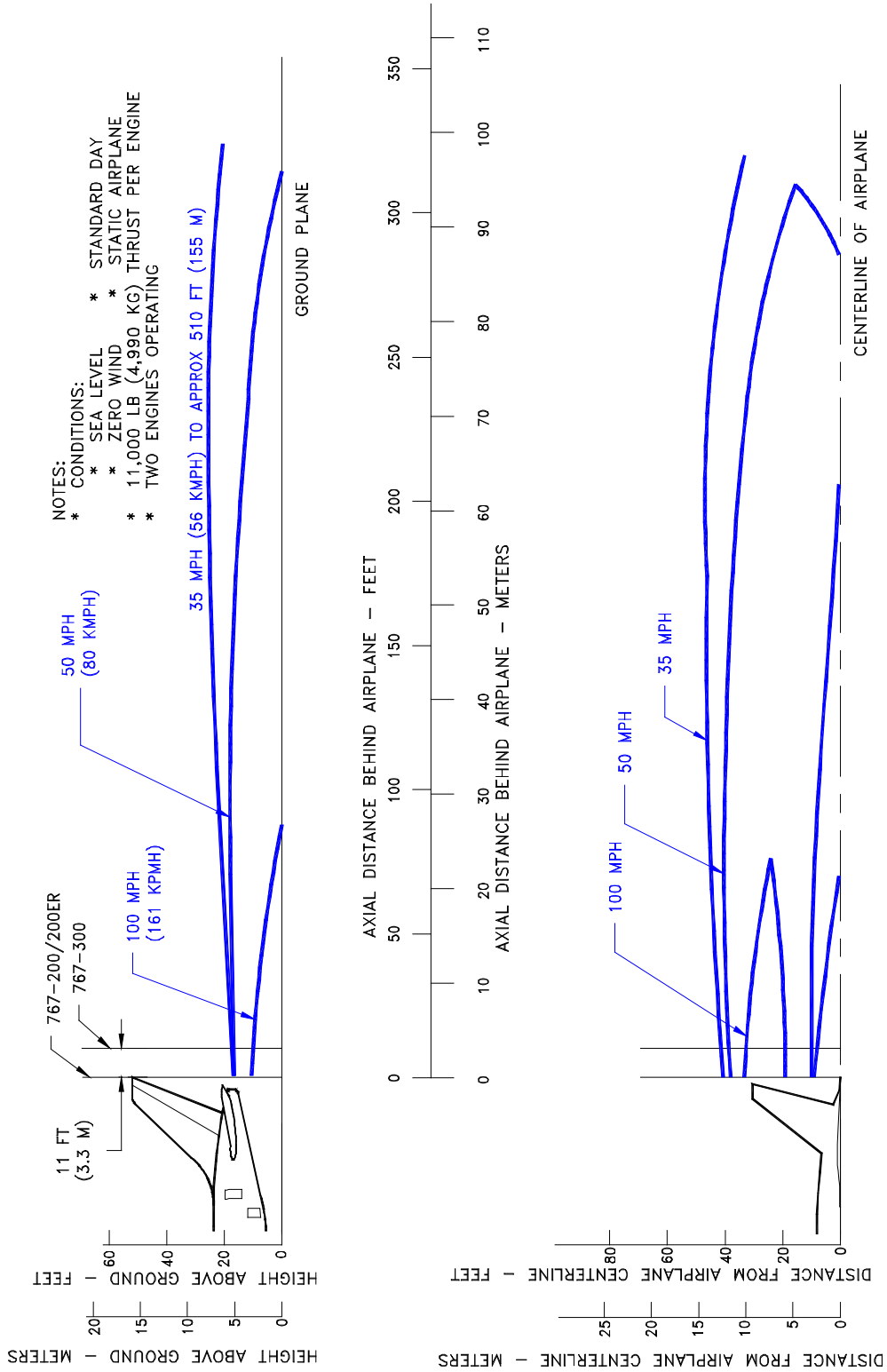

6.1.10 Jet Engine Exhaust Velocity Contours – High Breakaway Thrust: Model 767-400ER (All Engines)

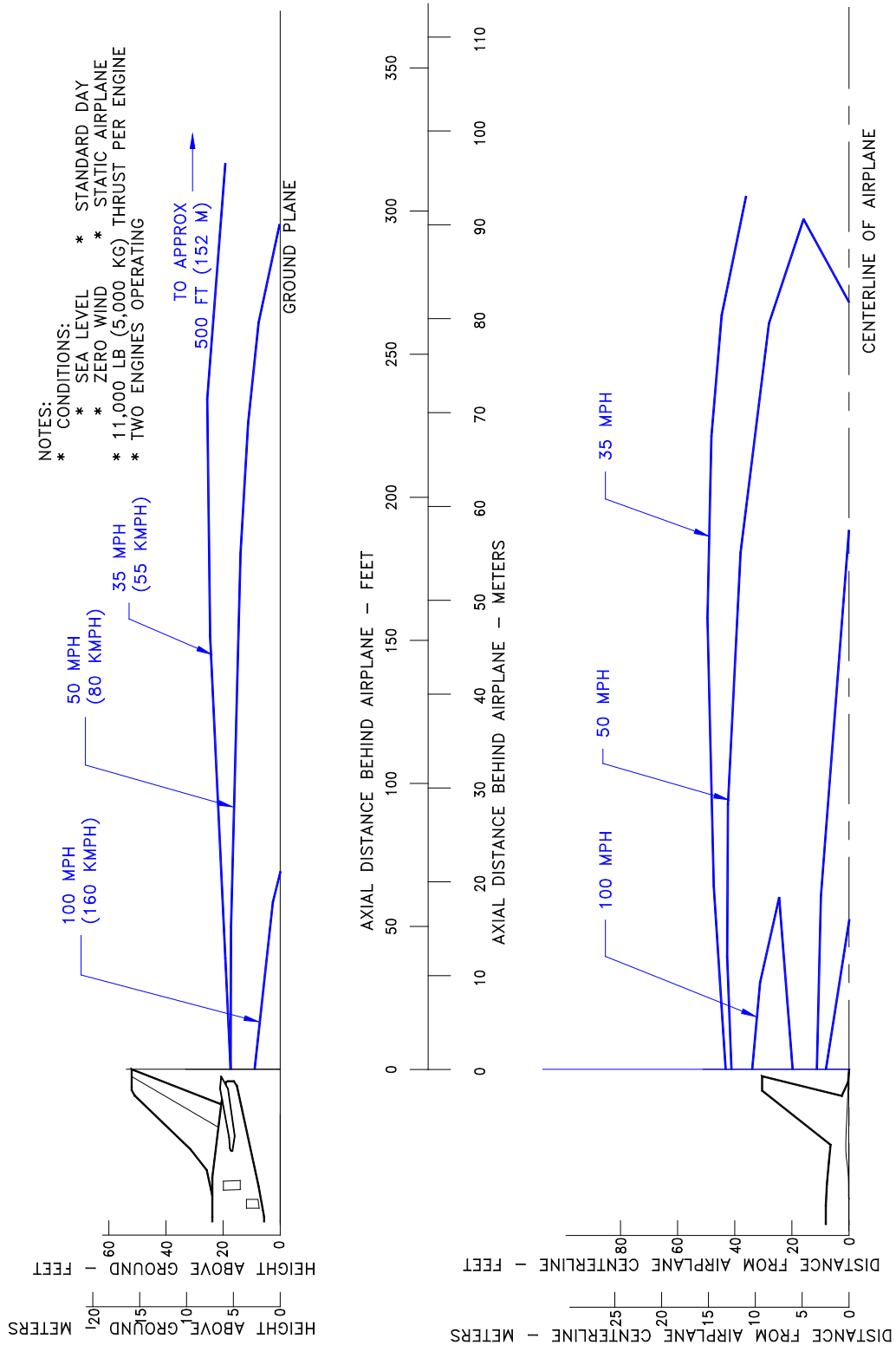

6.1.11 Jet Engine Exhaust Velocity Contours - Takeoff Thrust: Model 767-200, -200ER, -300 (JT9D-7R4D, -7R4E Engines)

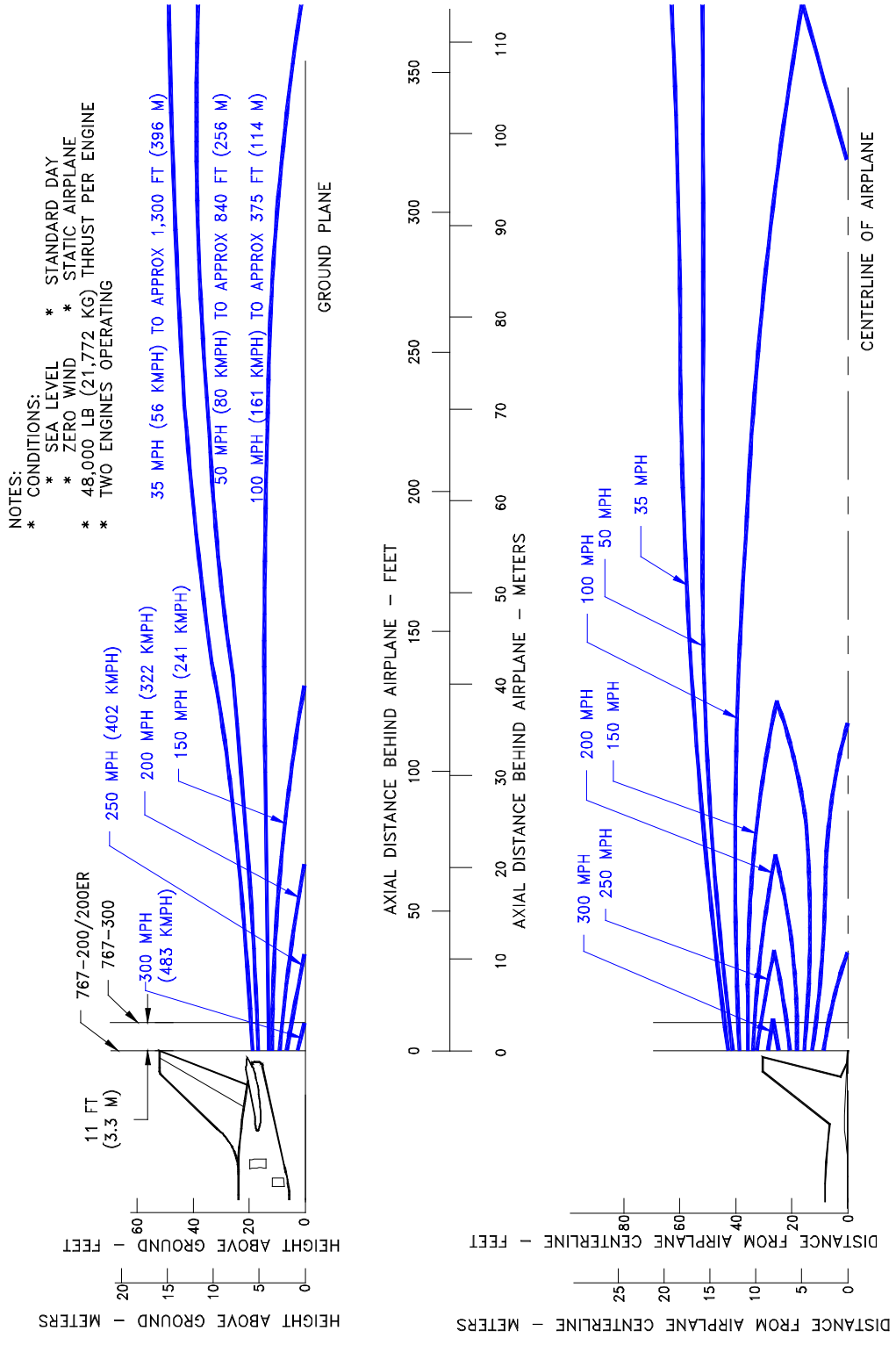

6.1.12 Jet Engine Exhaust Velocity Contours - Takeoff Thrust: Model 767-200, -200ER, -300 (CF6-80A, -80A2 Engines)

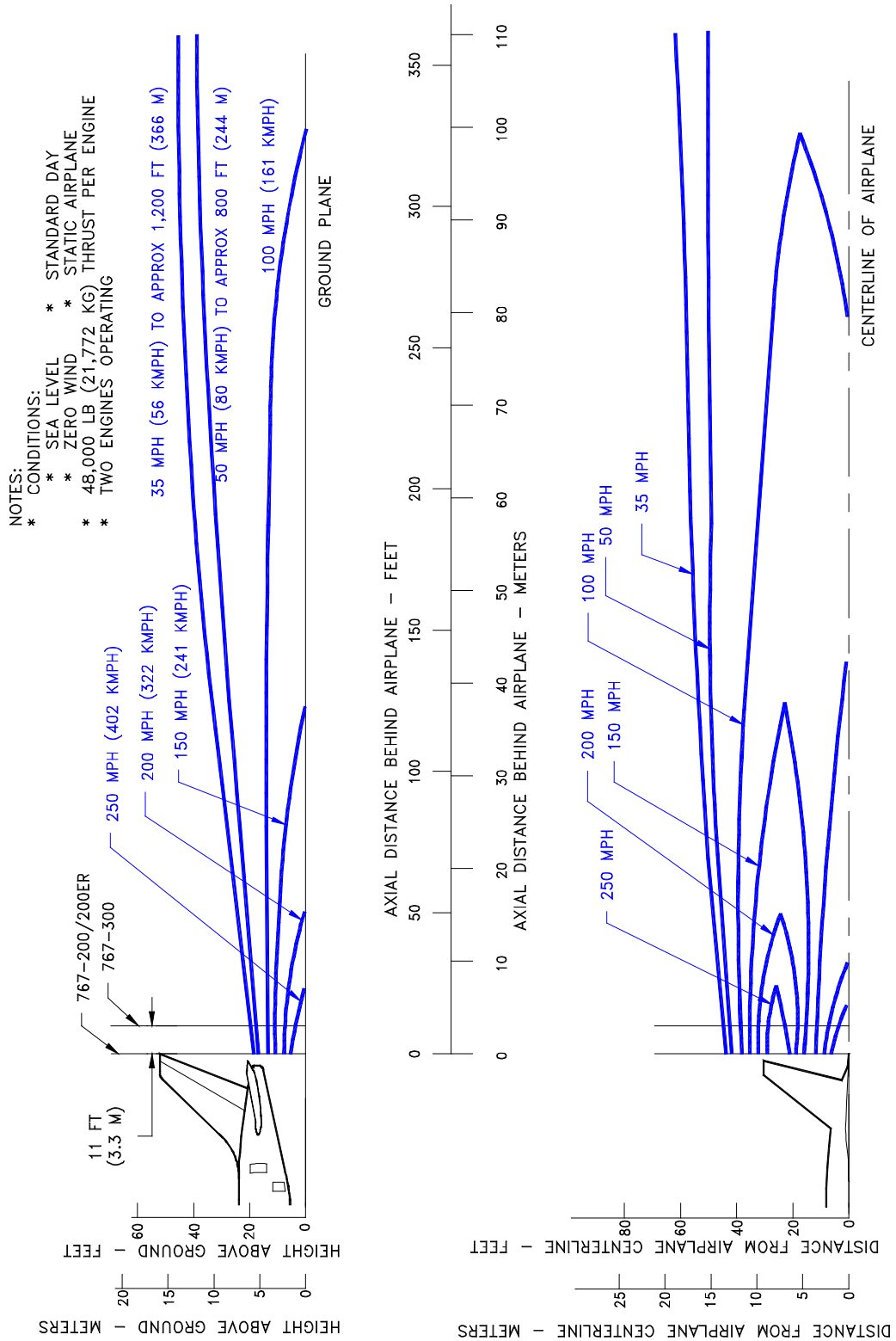

D6-58328

July 2021

6-13

REV I

6.1.13 Jet Engine Exhaust Velocity Contours - Takeoff Thrust: Model 767-300ER, -300 Freighter (PW4056, CF6-80C2 Engines)

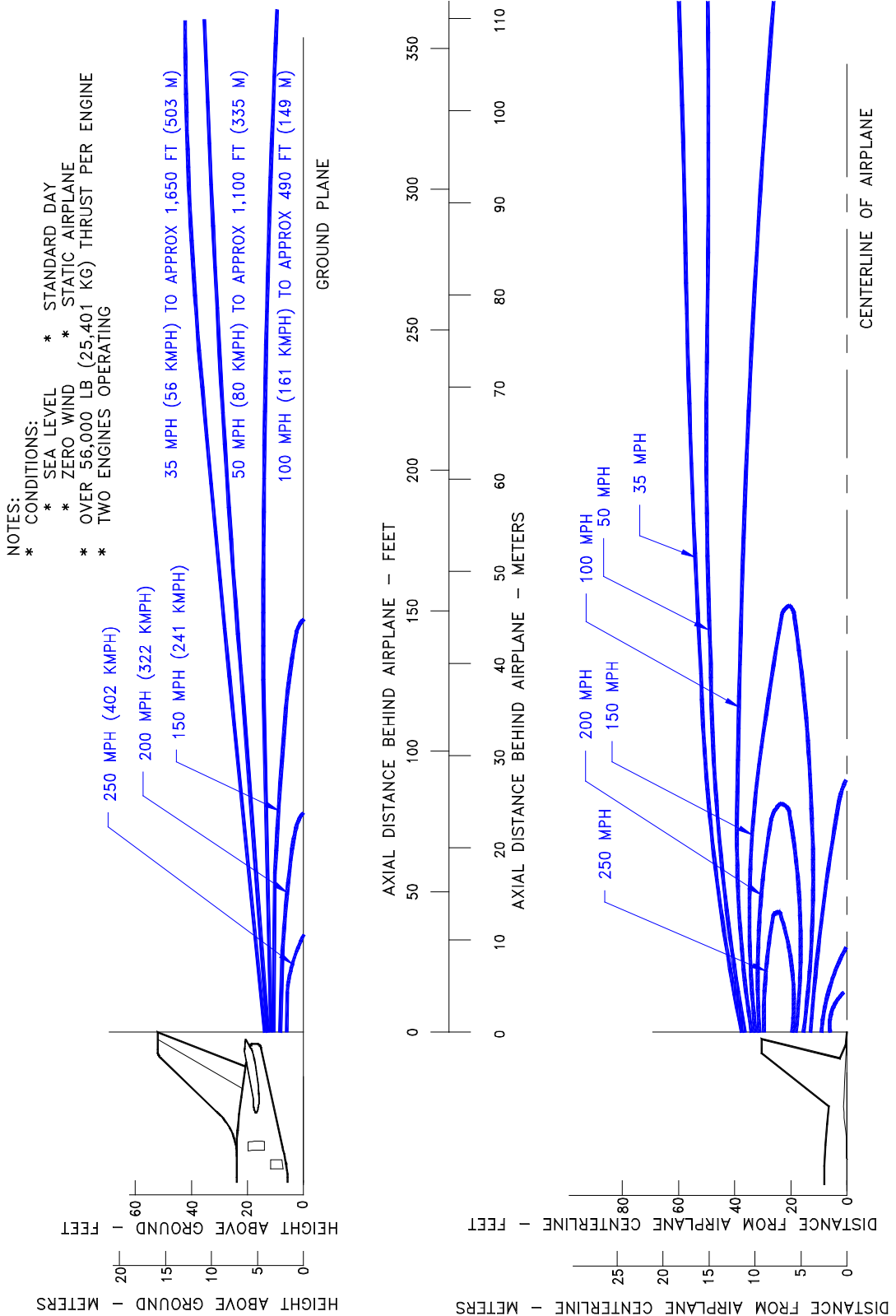

D6-58328

6.1.14 Jet Engine Exhaust Velocity Contours - Takeoff Thrust: Model 767-300, -300ER, -300 Freighter (RB211-524 Engines)

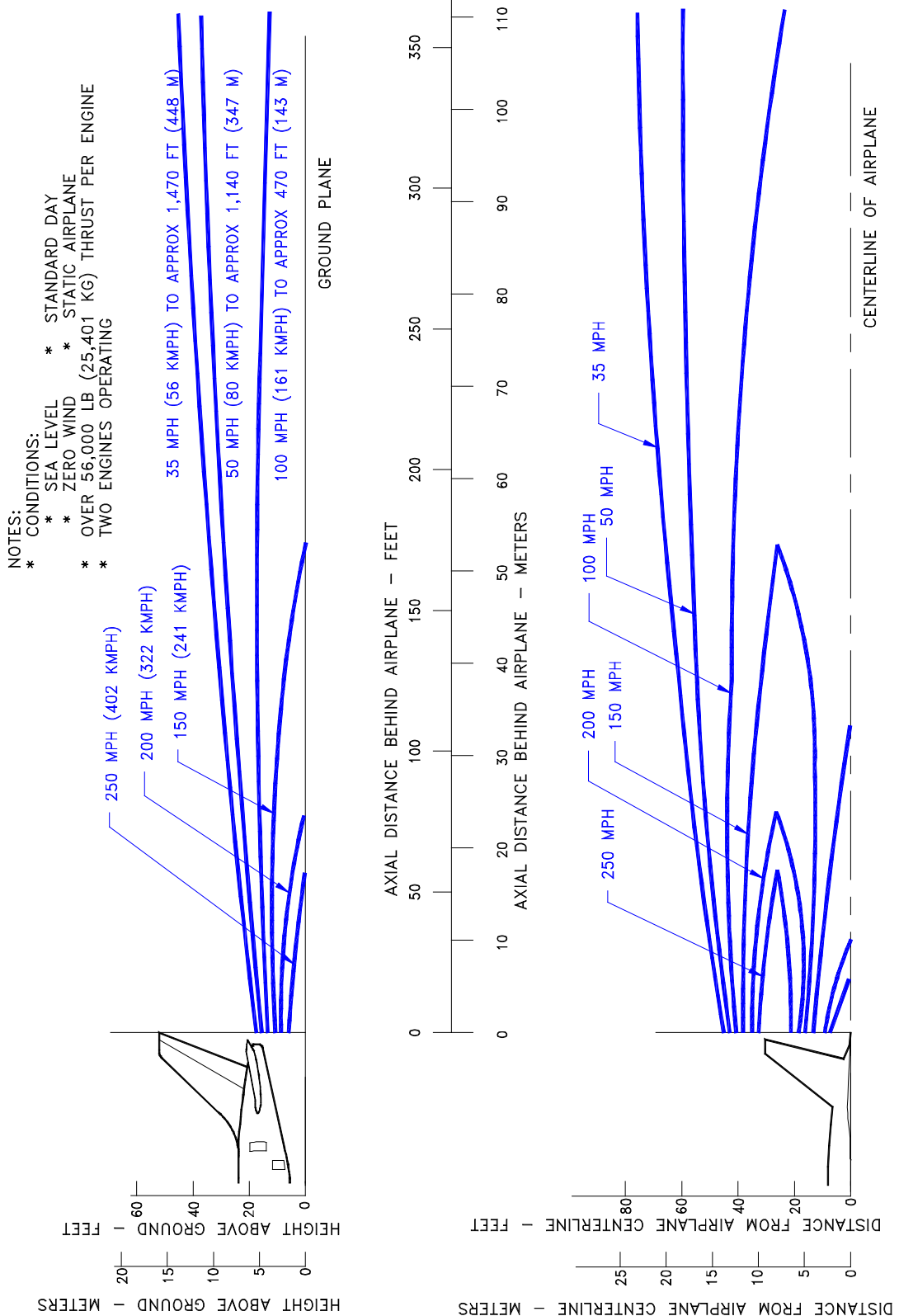

D6-58328

6.1.15 Jet Engine Exhaust Velocity Contours - Takeoff Thrust: Model 767-400ER (All Engines)

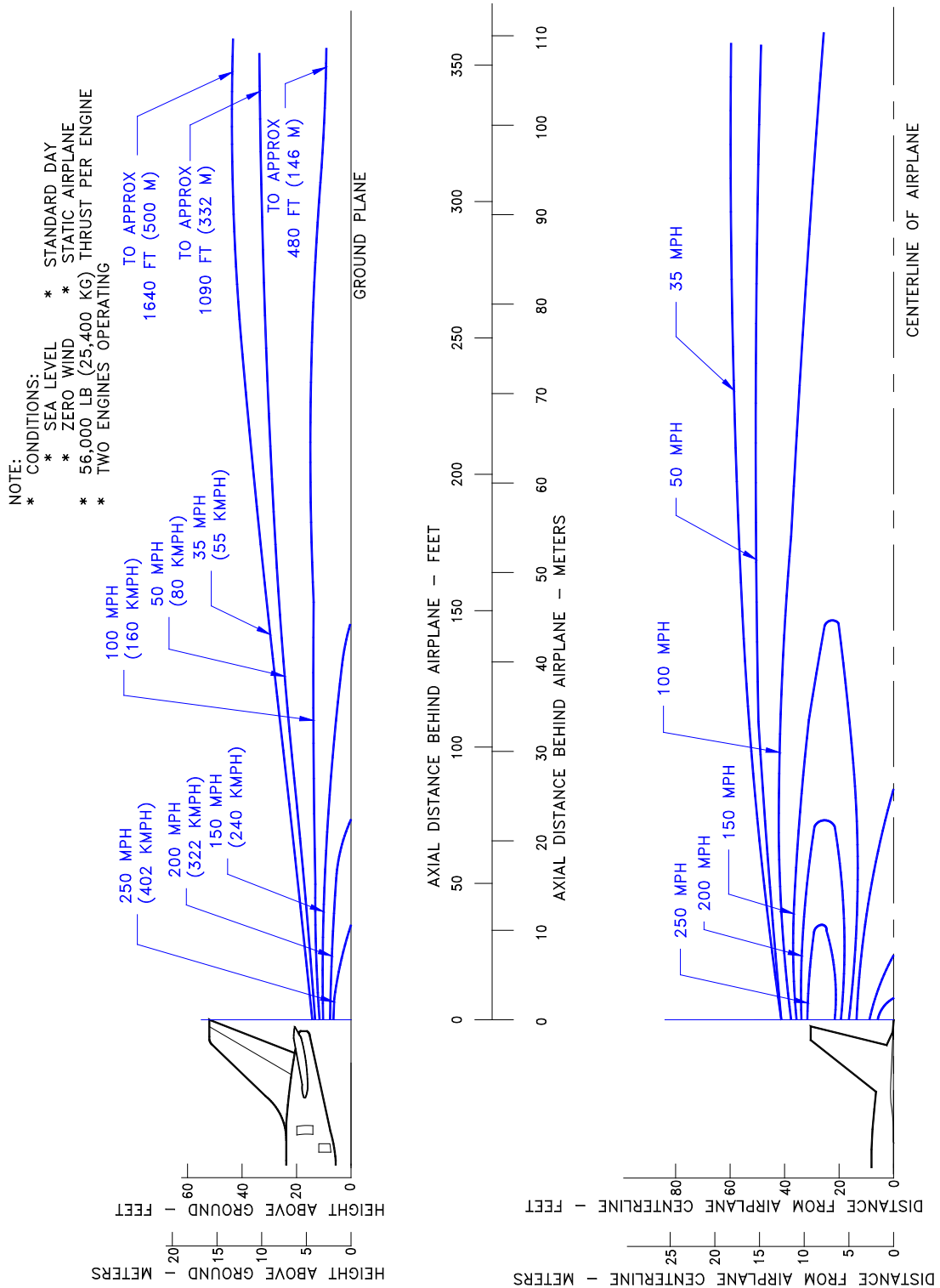

D6-58328

July 2021

REV I

6-16

6.1.16 Jet Engine Exhaust Temperature Contours – Idle Thrust: Model 767-200, -200ER, -300, -300ER, -300 Freighter, -400ER (All Engines)

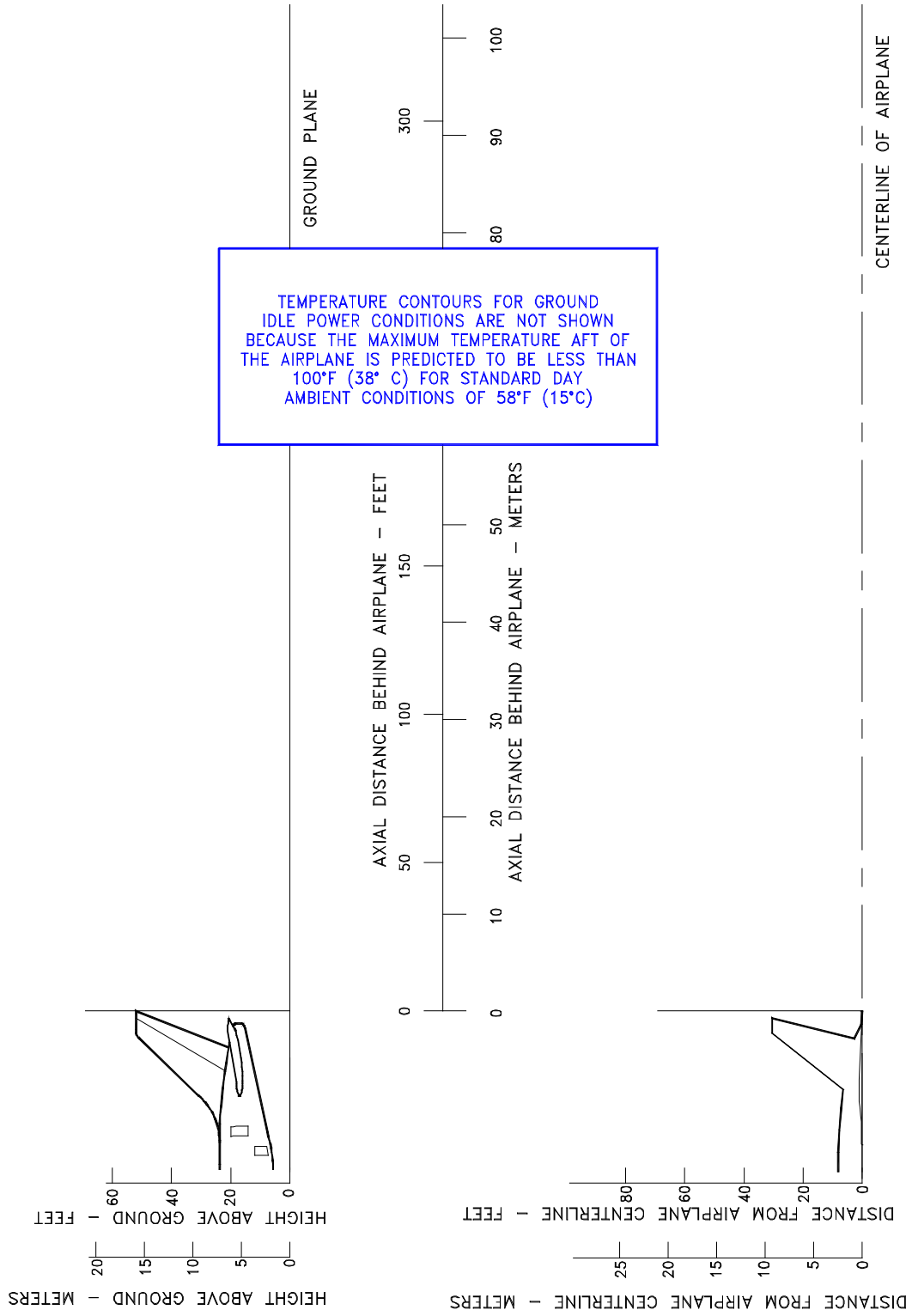

D6-58328

6.1.17 Jet Engine Exhaust Temperature Contours - Breakaway Thrust: Model 767-200, -200ER, -300, -300ER, -300 Freighter, -400ER (All Engines)

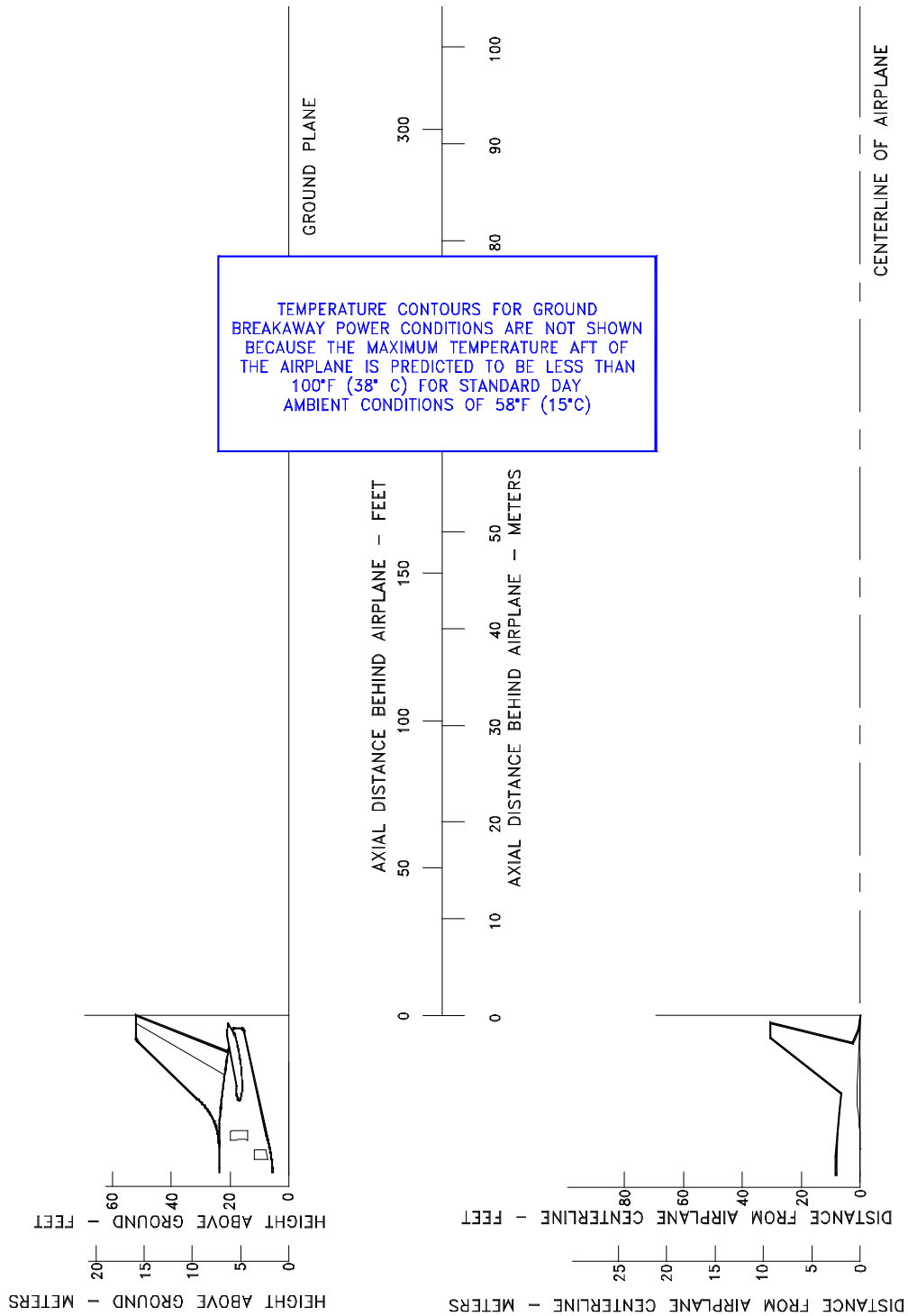

6.1.18 Jet Engine Exhaust Temperature Contours - Takeoff Thrust: Model 767-200, -200ER, -300 (JT9D-7R4E, -7R4E Engines)

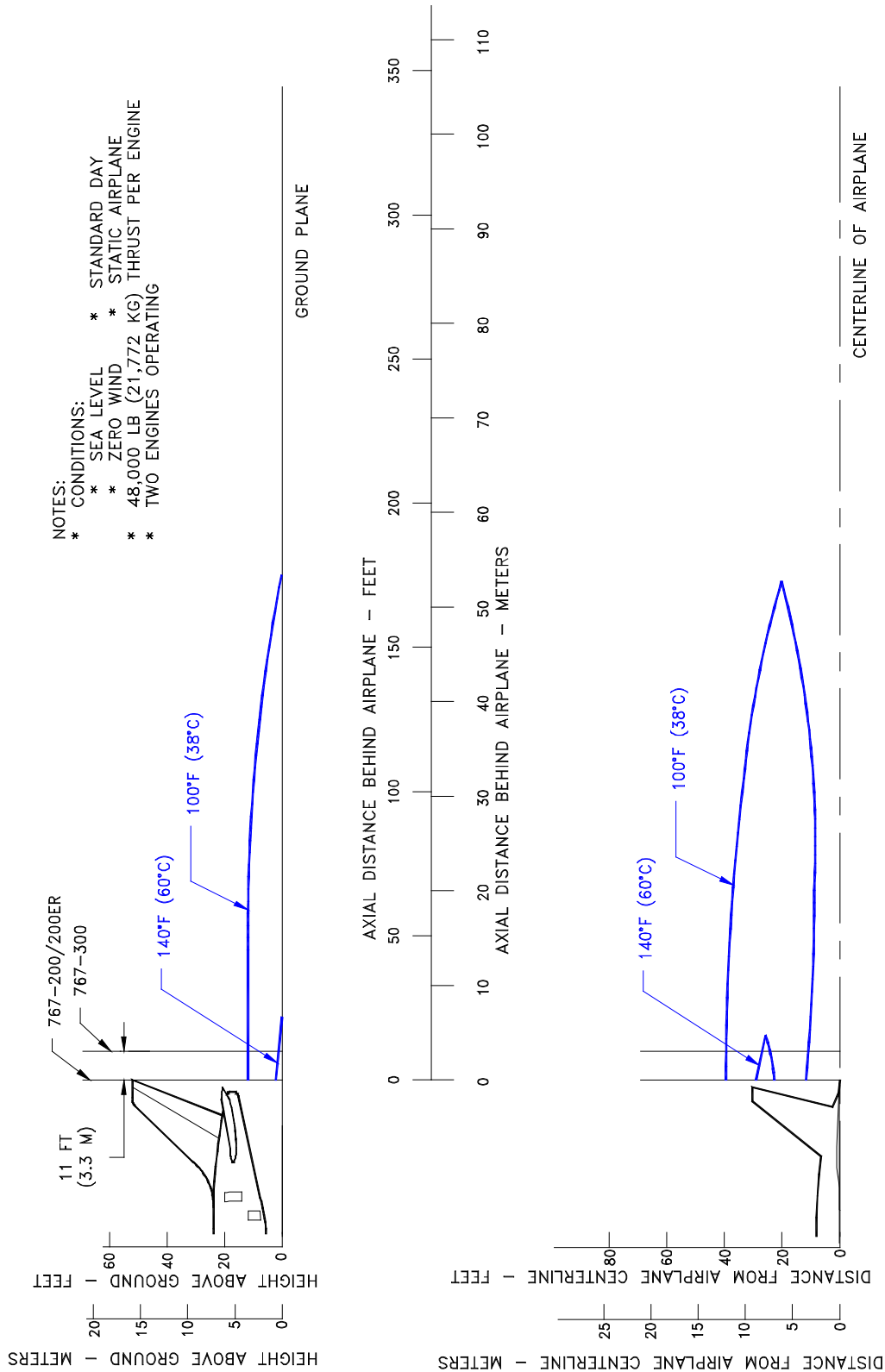

6.1.19 Jet Engine Exhaust Temperature Contours - Takeoff Thrust: Model 767-200, -200ER, -300 (CF6-80A, -80A2 Engines)

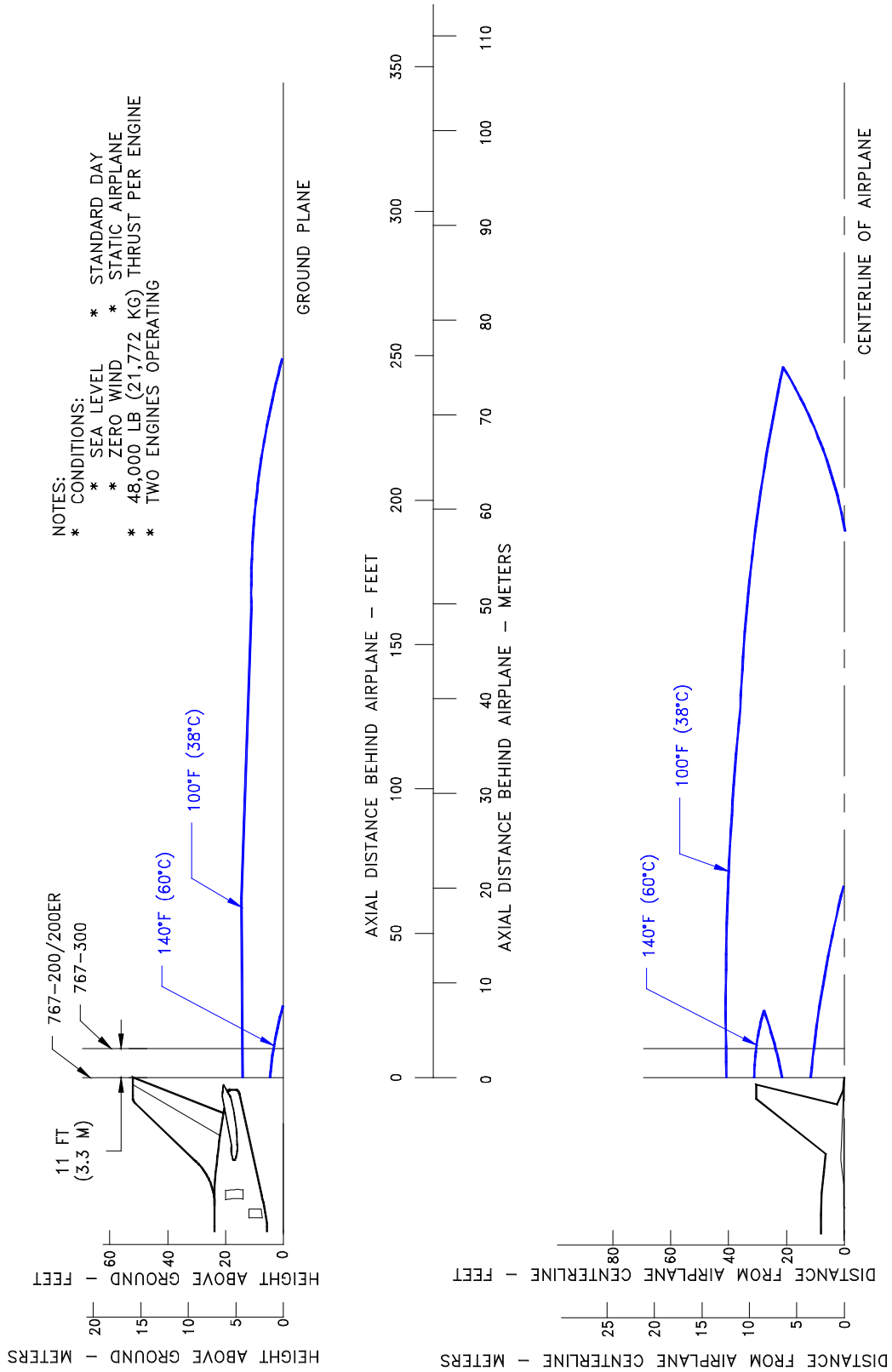

D6-58328

6.1.20 Jet Engine Exhaust Temperature Contours - Takeoff Thrust: Model 767-300ER, -300 Freighter (PW4000, CF6-80C2 Engines)

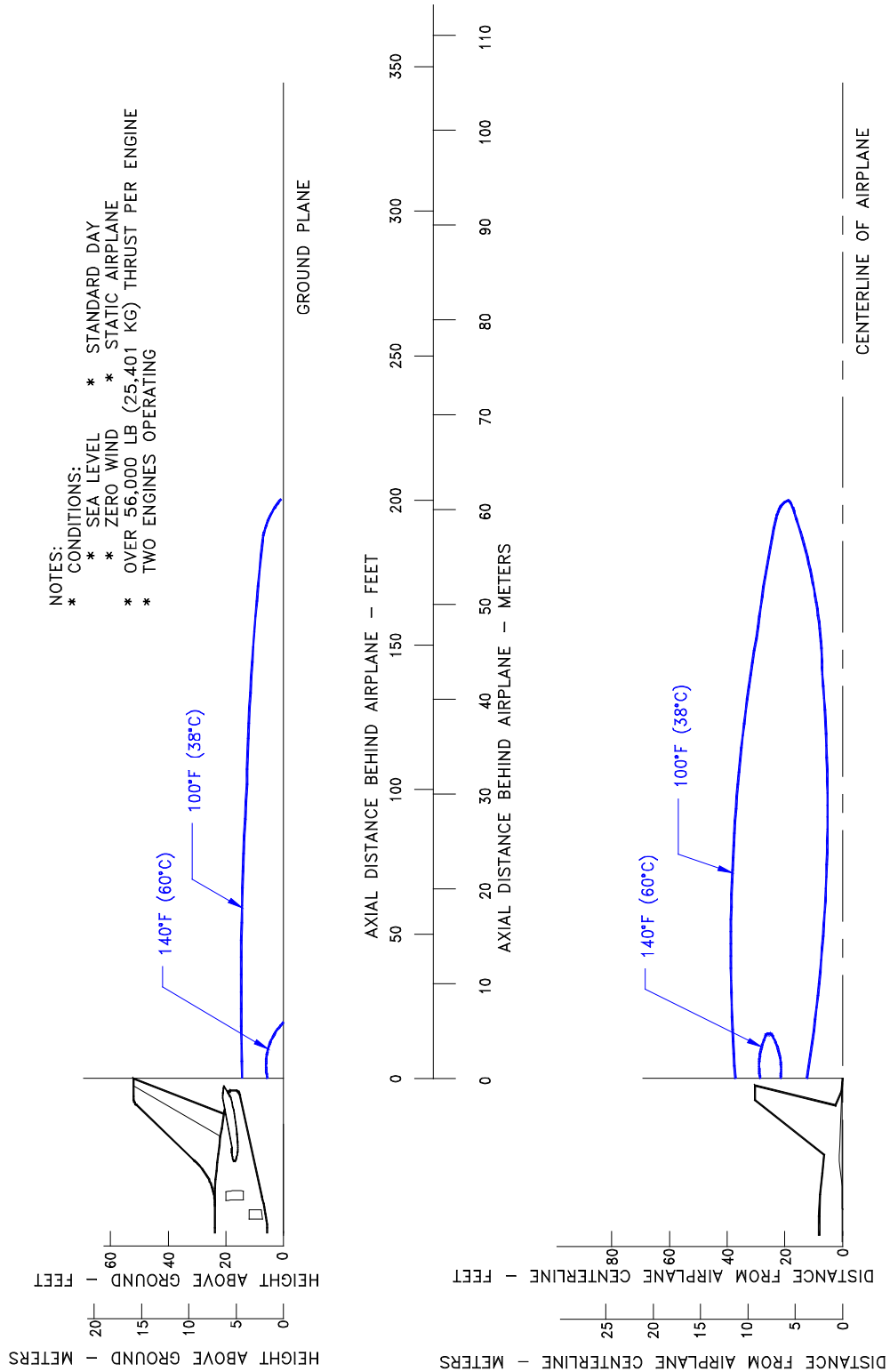

D6-58328

6.1.21 Jet Engine Exhaust Temperature Contours - Takeoff Thrust: Model 767-300, -300ER, -300 Freighter (RB211-524 Engines)

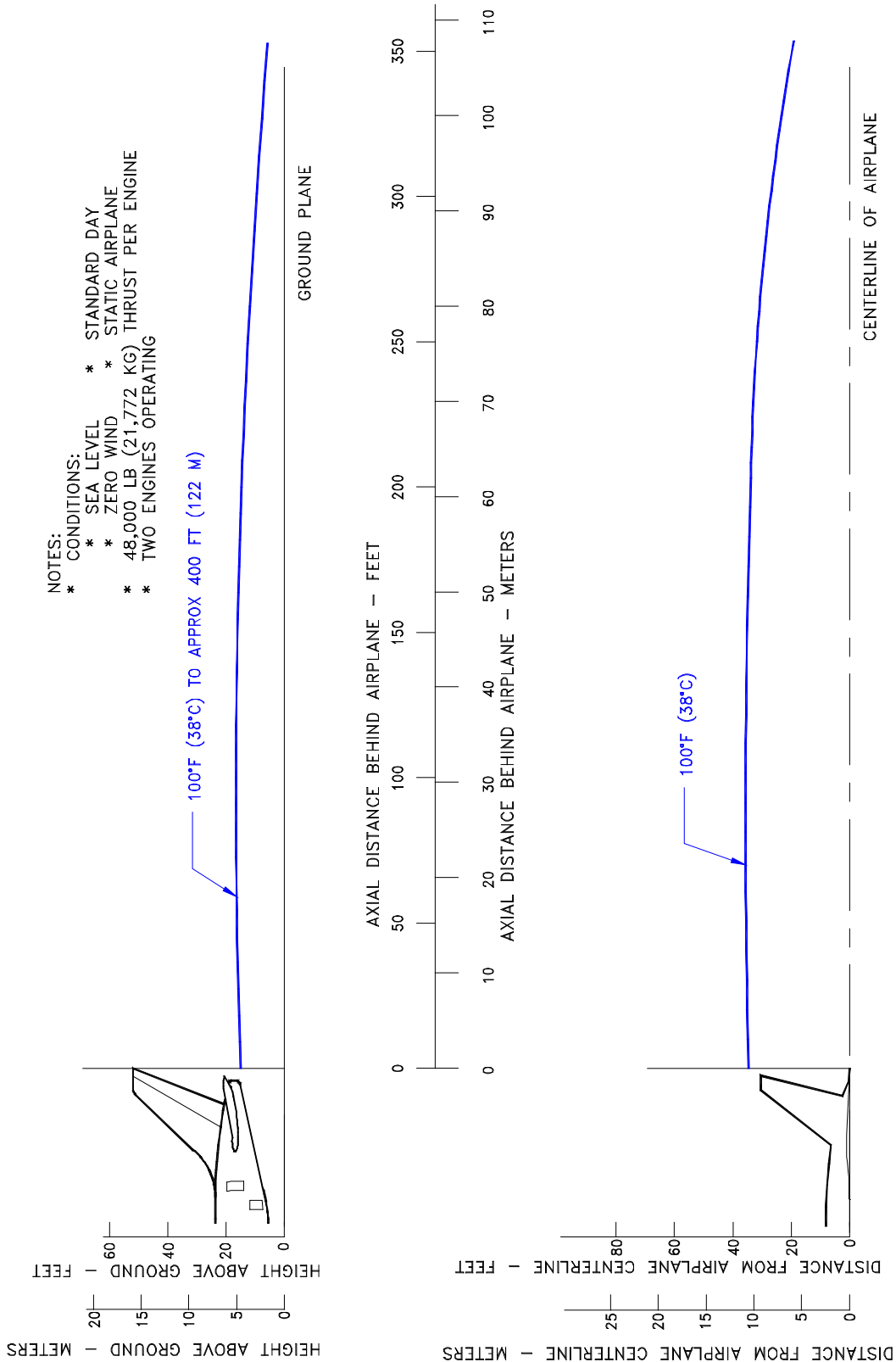

6.1.22 Jet Engine Exhaust Temperature Contours - Takeoff Thrust: Model 767-400ER (All Engines)

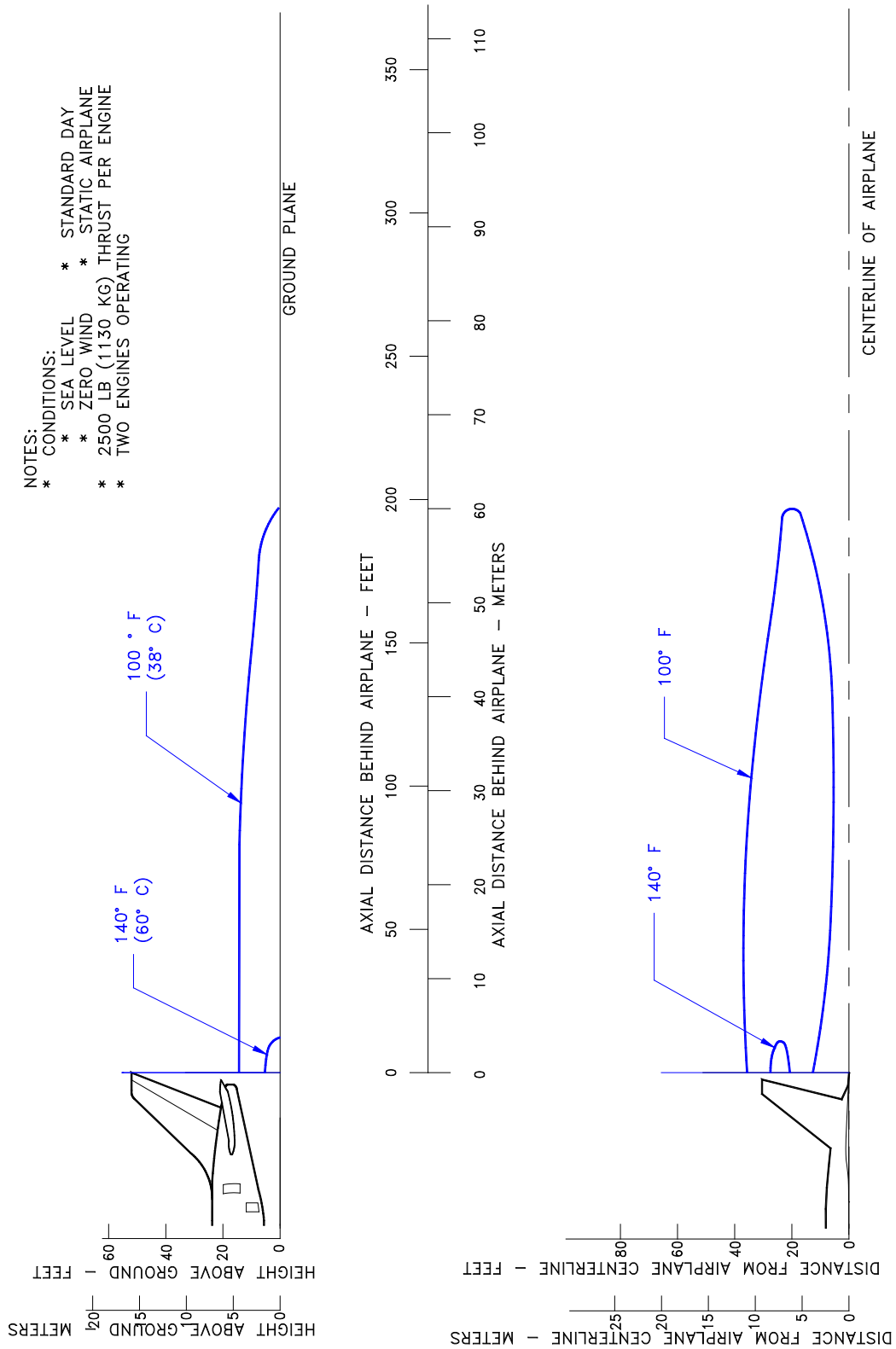

6.2 AIRPORT AND COMMUNITY NOISE

Airport noise is of major concern to the airport and community planner. The airport is a major element in the community's transportation system and, as such, is vital to its growth. However, the airport must also be a good neighbor, and this can be accomplished only with proper planning. Since aircraft noise extends beyond the boundaries of the airport, it is vital to consider the impact on surrounding communities. Many means have been devised to provide the planner with a tool to estimate the impact of airport operations. Too often they oversimplify noise to the point where the results become erroneous. Noise is not a simple subject; therefore, there are no simple answers.

The cumulative noise contour is an effective tool. However, care must be exercised to ensure that the contours, used correctly, estimate the noise resulting from aircraft operations conducted at an airport.

The size and shape of the single-event contours, which are inputs into the cumulative noise contours, are dependent upon numerous factors. They include the following:

1. Operational Factors
 - a. Aircraft Weight - Aircraft weight is dependent on distance to be traveled, en route winds, payload, and anticipated aircraft delay upon reaching the destination.
 - b. Engine Power Settings - The rates of ascent and descent and the noise levels emitted at the source are influenced by the power setting used.
 - c. Airport Altitude - Higher airport altitude will affect engine performance and thus can influence noise.
2. Atmospheric Conditions-Sound Propagation
 - a. Wind - With stronger headwinds, the aircraft can take off and climb more rapidly relative to the ground. Also, winds can influence the distribution of noise in surrounding communities.
 - b. Temperature and Relative Humidity - The absorption of noise in the atmosphere along the transmission path between the aircraft and the ground observer varies with both temperature and relative humidity.
3. Surface Condition-Shielding, Extra Ground Attenuation (EGA)
 - a. Terrain - If the ground slopes down after takeoff or up before landing, noise will be reduced since the aircraft will be at a higher altitude above ground. Additionally, hills, shrubs, trees, and large buildings can act as sound buffers.

All these factors can alter the shape and size of the contours appreciably. To demonstrate the effect of some of these factors, estimated noise level contours for two different operating conditions are shown below. These contours reflect a given noise level upon a ground level plane at runway elevation.

Condition 1

Landing	Takeoff
Maximum Design Landing Weight	Maximum Design Takeoff Weight
10-knot Headwind	Zero Wind
3° Approach	84 °F
84 °F	Humidity 15%
Humidity 15%	

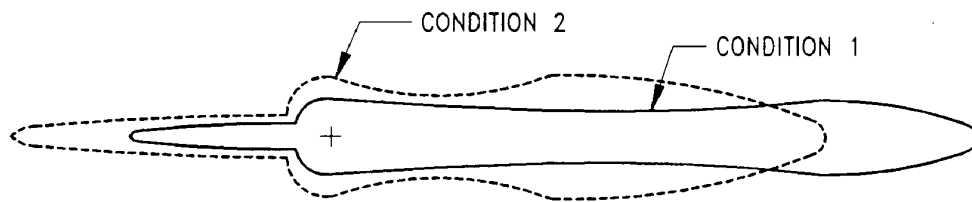

Condition 2

Landing	Takeoff
85% of Maximum Design Landing Weight	80% of Maximum Design Takeoff Weight
10-knot Headwind	10-knot Headwind
3° Approach	59 °F
59 °F	Humidity 70%
Humidity 70%	

As indicated from these data, the contour size varies substantially with operating and atmospheric conditions. Most aircraft operations are, of course, conducted at less than maximum gross weights because average flight distances are much shorter than maximum aircraft range capability and average load factors are less than 100%. Therefore, in developing cumulative contours for planning purposes, it is recommended that the airlines serving a particular city be contacted to provide operational information.

In addition, there are no universally accepted methods for developing aircraft noise contours or for relating the acceptability of specific zones to specific land uses. It is therefore expected that noise contour data for particular aircraft and the impact assessment methodology will be changing. To ensure that the best currently available information of this type is used in any planning study, it is recommended that it be obtained directly from the Office of Environmental Quality in the Federal Aviation Administration in Washington, D.C.

It should be noted that the contours shown herein are only for illustrating the impact of operating and atmospheric conditions and do not represent the single-event contour of the family of aircraft described in this document. It is expected that the cumulative contours will be developed as required by planners using the data and methodology applicable to their specific study.

7.0 PAVEMENT DATA

7.1 GENERAL INFORMATION

A brief description of the pavement charts that follow will help in their use for airport planning. Each airplane configuration is depicted with a minimum range of five loads imposed on the main landing gear to aid in interpolation between the discrete values shown. All curves for any single chart represent data based on rated loads and tire pressures considered normal and acceptable by current aircraft tire manufacturer's standards. Tire pressures, where specifically designated on tables and charts, are at values obtained under loaded conditions as certificated for commercial use.

Section 7.2 presents basic data on the landing gear footprint configuration, maximum design taxi loads, and tire sizes and pressures.

Maximum pavement loads for certain critical conditions at the tire-to-ground interface are shown in Section 7.3, with the tires having equal loads on the struts.

Pavement requirements for commercial airplanes are customarily derived from the static analysis of loads imposed on the main landing gear struts. The charts in Section 7.4 are provided in order to determine these loads throughout the stability limits of the airplane at rest on the pavement. These main landing gear loads are used as the point of entry to the pavement design charts, interpolating load values where necessary.

The flexible pavement design curves based on the US Army Corp of Engineers Method and the rigid pavement curves based on the Portland Cement Association Design Method are no longer provided in Sections 7.5 and 7.7. Refer to the State's design standards for pavement design requirements. For US airports, refer to FAA Advisory Circular (AC) 150/5320-6, "Pavement Design" and pavement design program FAARFIELD for flexible and rigid pavement design requirements.

The Load Classification Number (LCN) curves are no longer provided in section 7.6 and 7.8 since the LCN system for reporting pavement strength is obsolete, being replaced by the ICAO recommended ACN/PCN system in 1983. For questions regarding the LCN system contact Boeing Airport Compatibility Engineering:

AirportCompatibility@boeing.com

The ACN/PCN system (Section 7.10) as referenced in ICAO Annex 14, "Aerodromes," 8th Edition, July 2018, provides a standardized international airplane/pavement rating system replacing the various S, T, TT, LCN, AUW, ISWL, etc., rating systems used throughout the world. ACN is the Aircraft Classification Number and PCN is the Pavement Classification Number. An aircraft having an ACN equal to or less than the PCN can operate on the pavement subject to any limitation on the tire pressure. Numerically, the ACN is two times the derived single-wheel load expressed in thousands of kilograms, where the derived single wheel load is defined as the load on a single tire inflated to 181 psi (1.25 MPa) that would have the same pavement requirements as the aircraft. Computationally, the ACN/PCN system uses the PCA program PDILB for rigid pavements

and S-77-1 for flexible pavements to calculate ACN values. The method of pavement evaluation is left up to the airport with the results of their evaluation presented as follows:

PCN	PAVEMENT TYPE	SUBGRADE CATEGORY	TIRE CATEGORY	PRESSURE	EVALUATION METHOD
	R = Rigid	A = High	W = No Limit		T = Technical
	F = Flexible	B = Medium	X = To 254 psi (1.75 MPa)		U = Using Aircraft
		C = Low	Y = To 181 psi (1.25 MPa)		
		D = Ultra Low	Z = To 73 psi (0.5 MPa)		

ACN values for flexible pavements are calculated for the following four subgrade categories:

Code A - High Strength - CBR 15

Code B - Medium Strength - CBR 10

Code C - Low Strength - CBR 6

Code D - Ultra Low Strength - CBR 3

ACN values for rigid pavements are calculated for the following four subgrade categories:

Code A - High Strength, $k = 552.6 \text{ pci (150 MN/m}^3\text{)}$

Code B - Medium Strength, $k = 294.7 \text{ pci (80 MN/m}^3\text{)}$

Code C - Low Strength, $k = 147.4 \text{ pci (40 MN/m}^3\text{)}$

Code D - Ultra Low Strength, $k = 73.7 \text{ pci (20 MN/m}^3\text{)}$

7.2 LANDING GEAR FOOTPRINT

7.2.1 Landing Gear Footprint: Model 767-200, -200ER

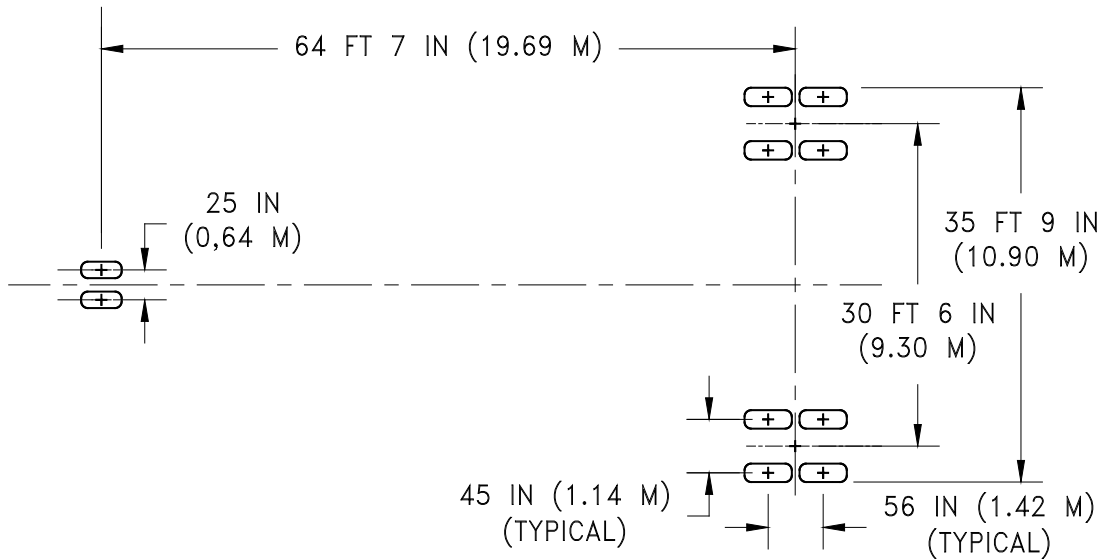

	UNITS	MODEL 767-200			MODEL 767-200ER	
MAXIMUM DESIGN TAXI WEIGHT	LB	317,000	352,200	361,000	352,200	396,000
	KG	143,788	159,755	163,747	159,755	179,623
PERCENT OF WEIGHT ON MAIN GEAR	%	SEE SECTION 7.4.1			SEE SECTION 7.4.2	
NOSE GEAR TIRE SIZE	IN	H37 x 14-15 22PR			H37 x 14-15 22PR	H37 x 14-15 24PR
NOSE GEAR TIRE PRESSURE	PSI	146	156	156	156	185
	MPa	1.01	1.08	1.08	1.08	1.28
MAIN GEAR TIRE SIZE	IN	H46 x 18-20 26PR	H46x 18-20 28PR	H46 x 18-20 28PR	H46 x 18-20 28PR	H46 x 18-20 32PR
MAIN GEAR TIRE PRESSURE	PSI	165	175	190	175	190
	MPa	1.14	1.21	1.31	1.21	1.31

7.2.2 Landing Gear Footprint: Model 767-300, -300ER, -300 Freighter

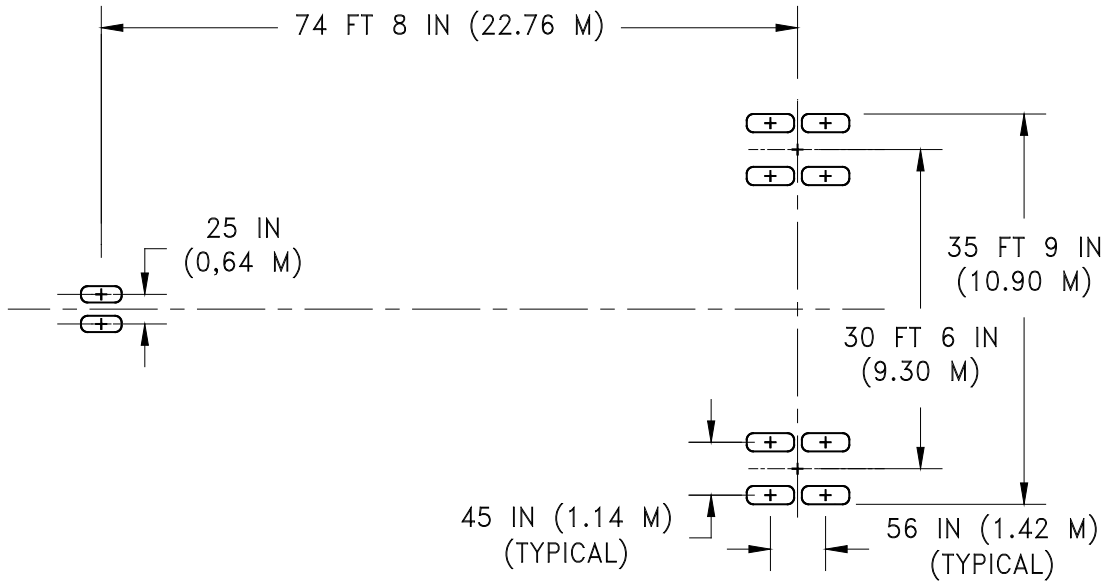

	UNITS	MODEL 767-300			MODEL 767-300ER		MODEL -300 FREIGHTER	
MAXIMUM DESIGN TAXI WEIGHT	LB	290,700	327,000	361,000	401,000	413,000	409,000	413,000
	KG	131,859	148,325	163,747	181,890	187,334	185,519	187,334
PERCENT OF WEIGHT ON MAIN GEAR	%	SEE SECTION 7.4.4			SEE SECTION 7.4.5		SEE SECTION 7.4.6	
NOSE GEAR TIRE SIZE	IN	H37 x 14-15 22PR			H37 x 14-15 22PR	H37 x 14-15 24PR	H37 x 14-15 24PR	
NOSE GEAR TIRE PRESSURE	PSI	146	146	167	172		172	
	MPa	1.01	1.01	1.15	1.19		1.19	
MAIN GEAR TIRE SIZE	IN	H46 x 18-20 26PR		H46 x 18-20 32PR	H46 x 18-20 32PR		H46 x 18-20 32PR	
MAIN GEAR TIRE PRESSURE	PSI	165	165	200	200		200	
	MPa	1.14	1.14	1.38	1.38		1.38	

D6-58328

REV I

July 2021

7-4

7.2.3 Landing Gear Footprint: Model 767-400ER

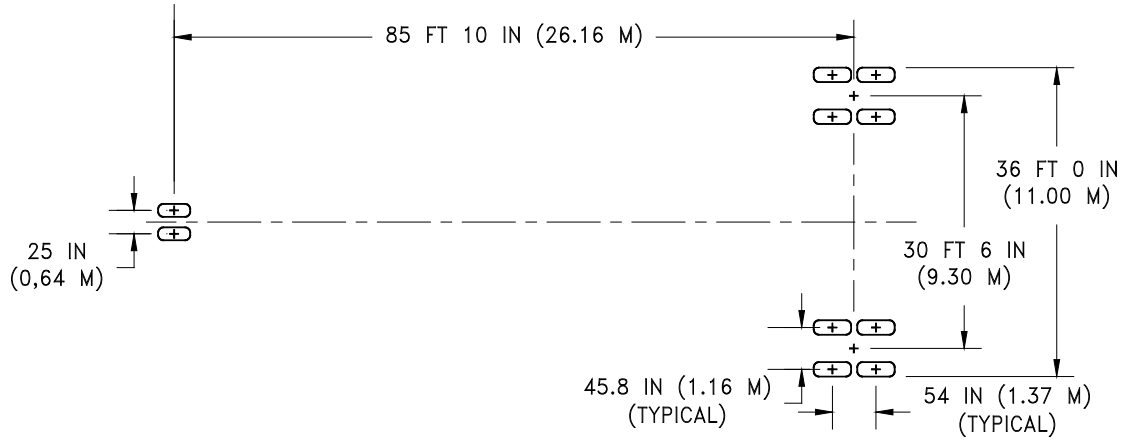

	UNITS	MODEL 767-400ER
MAXIMUM DESIGN TAXI WEIGHT	LB	451,000
	KG	204,570
PERCENT OF WEIGHT ON MAIN GEAR	%	SEE SECTION 7.4
NOSE GEAR TIRE SIZE	IN	H37 x 14 - 15 22PR
NOSE GEAR TIRE PRESSURE	PSI	170
	MPa	1.17
MAIN GEAR TIRE SIZE	IN	50 x 20 R22 32 PR
MAIN GEAR TIRE PRESSURE	PSI	213
	MPa	1.47

7.3 MAXIMUM PAVEMENT LOADS

7.3.1 Maximum Pavement Loads: Model 767-200, -200ER,-300,-300ER

- V_{NG} = MAXIMUM VERTICAL NOSE GEAR GROUND LOAD AT MOST FORWARD CENTER OF GRAVITY
- V_{MG} = MAXIMUM VERTICAL MAIN GEAR GROUND LOAD AT MOST AFT CENTER OF GRAVITY
- H = MAXIMUM HORIZONTAL GROUND LOAD FROM BRAKING

NOTE: ALL LOADS CALCULATED USING AIRPLANE MAXIMUM DESIGN TAXI WEIGHT

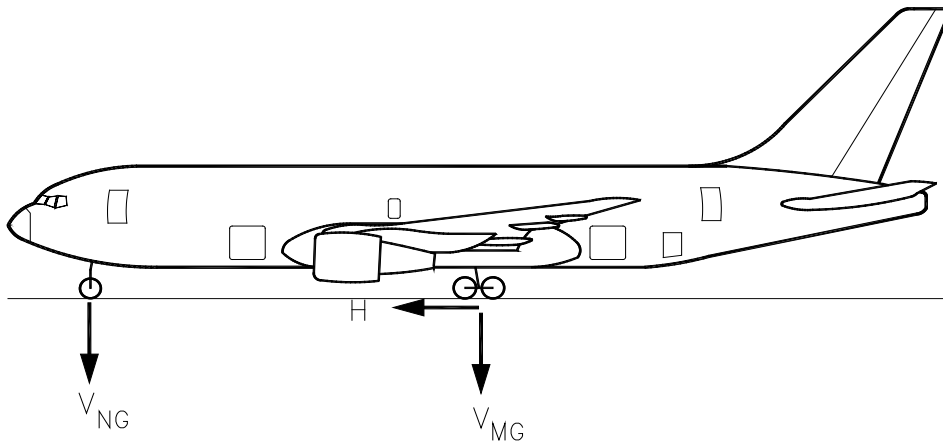

MODEL	UNITS	MAX DESIGN TAXI WEIGHT	V_{NG}		V_{MG} PER STRUT	H PER STRUT	
			STATIC AT MOST FWD C.G.	STATIC + BRAKING 10 FT/SEC ² DECEL	MAX LOAD AT STATIC AFT C.G.	STEADY BRAKING 10 FT/SEC ² DECEL	AT INSTANTANEOUS BRAKING ($u = 0.8$)
767-200	LB	317,000	40,632	60,070	145,028	49,230	116,022
	KG	143,788	18,430	27,247	65,784	22,330	52,626
767-200	LB	352,200	43,309	64,906	162,012	54,697	129,610
	KG	159,755	19,644	29,440	73,487	24,810	58,790
767-200	LB	361,000	43,728	65,864	165,158	56,063	132,126
	KG	163,746	19,835	29,875	74,915	25,430	59,931
767-200ER	LB	352,200	43,309	64,906	162,540	54,697	130,032
	KG	159,755	19,644	29,440	73,727	24,810	58,982
767-200ER	LB	396,000	44,691	68,973	179,784	61,499	143,827
	KG	179,623	20,272	31,286	81,549	27,895	65,239
767-300	LB	290,700	37,854	53,272	137,995	45,146	110,396
	KG	131,859	17,170	24,164	62,593	20,478	50,075
767-300	LB	327,000	41,108	58,451	151,532	50,783	121,226
	KG	148,325	18,646	26,513	68,734	23,035	54,987
767-300	LB	361,000	45,095	64,241	171,367	56,063	137,094
	KG	163,746	20,455	29,139	77,730	25,430	62,185
767-300ER	LB	401,000	48,284	69,553	187,147	62,275	149,718
	KG	181,890	21,901	31,549	84,888	28,247	67,910
767-300ER	LB	413,000	44,365	66,270	190,765	64,139	152,612
	KG	187,334	20,124	30,060	86,530	29,093	69,224

7.3.2 Maximum Pavement Loads: Model 767-400ER, -300 Freighter

- V_{NG} = MAXIMUM VERTICAL NOSE GEAR GROUND LOAD AT MOST FORWARD CENTER OF GRAVITY
- V_{MG} = MAXIMUM VERTICAL MAIN GEAR GROUND LOAD AT MOST AFT CENTER OF GRAVITY
- H = MAXIMUM HORIZONTAL GROUND LOAD FROM BRAKING

NOTE: ALL LOADS CALCULATED USING AIRPLANE MAXIMUM DESIGN TAXI WEIGHT

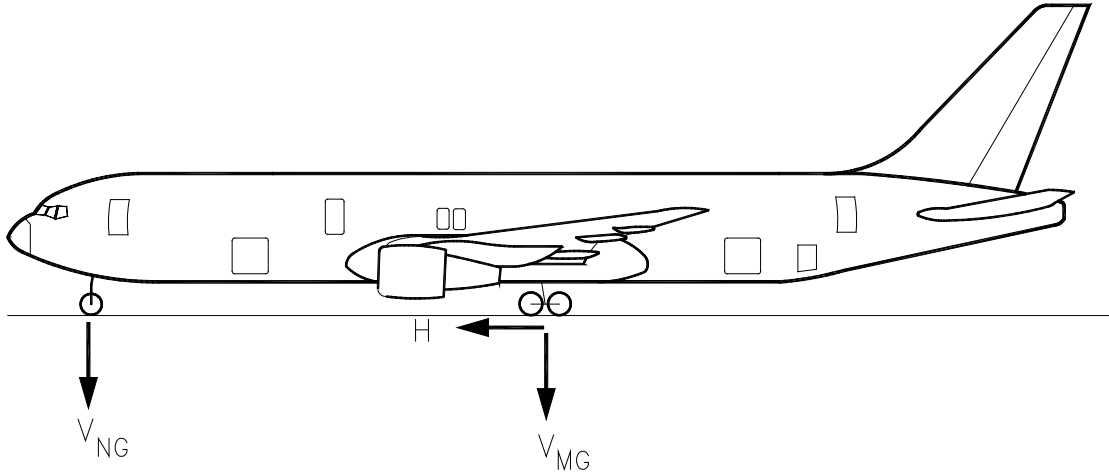

MODEL	UNITS	MAX DESIGN TAXI WEIGHT	V_{NG}		V_{MG} PER STRUT	H PER STRUT	
			STATIC AT MOST FWD C.G.	STATIC + BRAKING 10 FT/SEC ² DECEL	MAX LOAD AT STATIC AFT C.G.	STEADY BRAKING 10 FT/SEC ² DECEL	AT INSTANTANEOUS BRAKING (u = 0.8)
767-300F	LB	409,000	48,272	69,964	184,254	63,518	147,403
	KG	185,519	21,896	31,735	83,576	28,811	66,861
767-300F	LB	413,000	44,365	66,270	190,434	64,139	152,347
	KG	187,334	20,124	30,060	86,379	29,093	69,103
767-400ER	LB	451,000	37,821	58,629	211,745	70,040	169,396
	KG	204,570	17,155	26,594	96,046	31,770	76,837

7.4 LANDING GEAR LOADING ON PAVEMENT

7.4.1 Landing Gear Loading on Pavement: Model 767-200

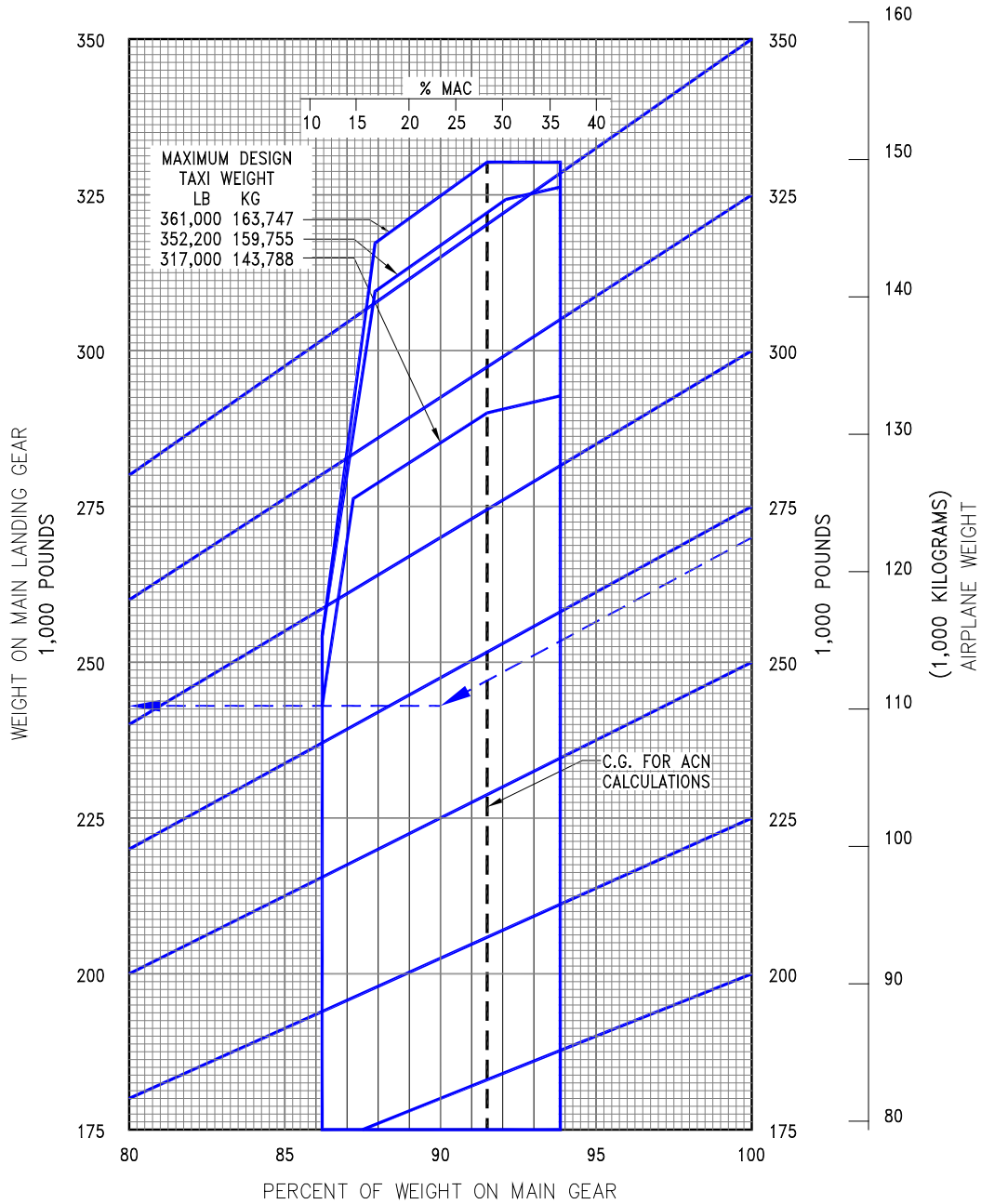

D6-58328

REV I

July 2021

7-8

7.4.2 Landing Gear Loading On Pavement: Model 767-200ER

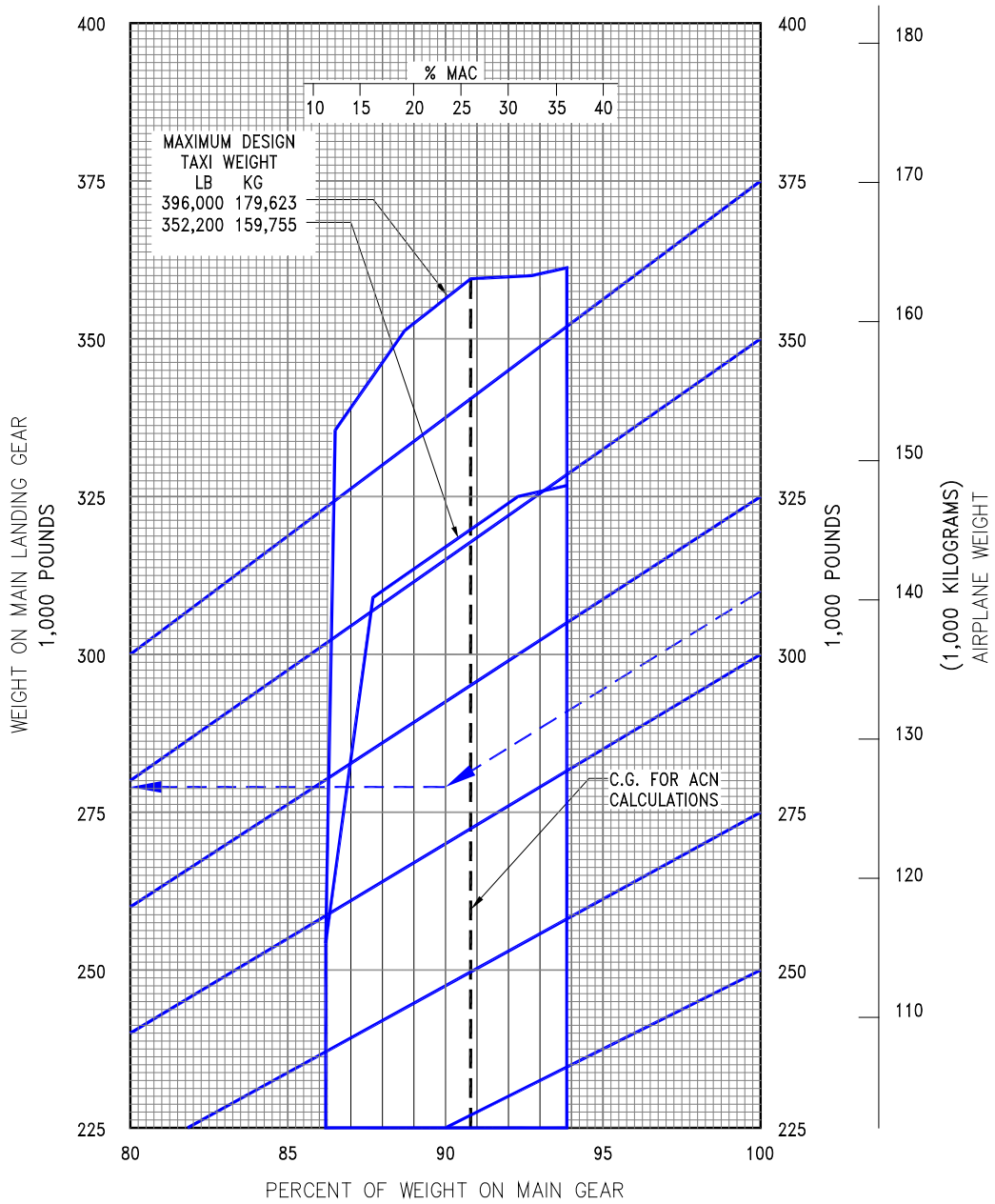

D6-58328

REV I

July 2021

7-9

7.4.3 Landing Gear Loading On Pavement: Model 767-300

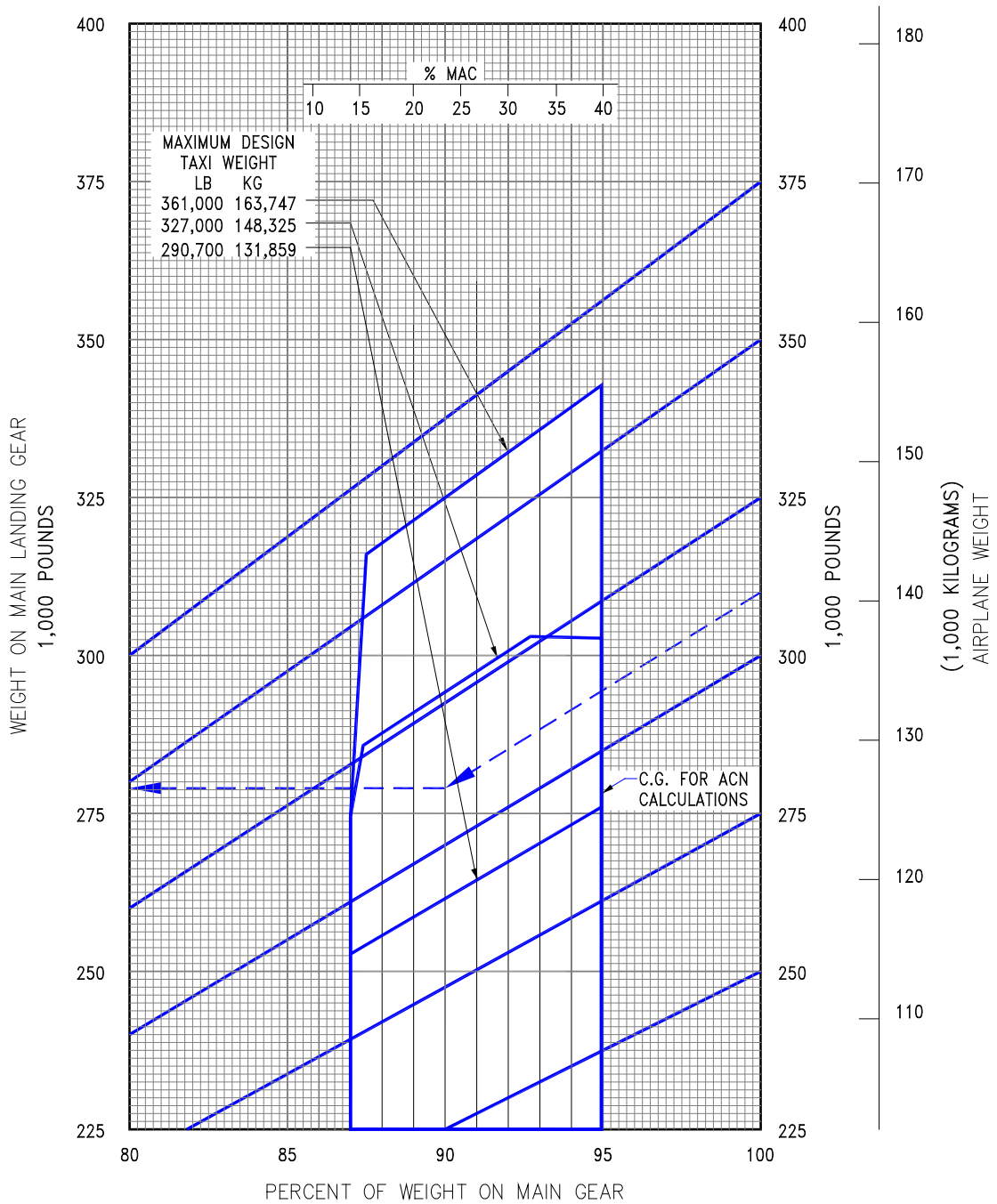

D6-58328

REV I

July 2021

7-10

7.4.4 Landing Gear Loading On Pavement: Model 767-300ER

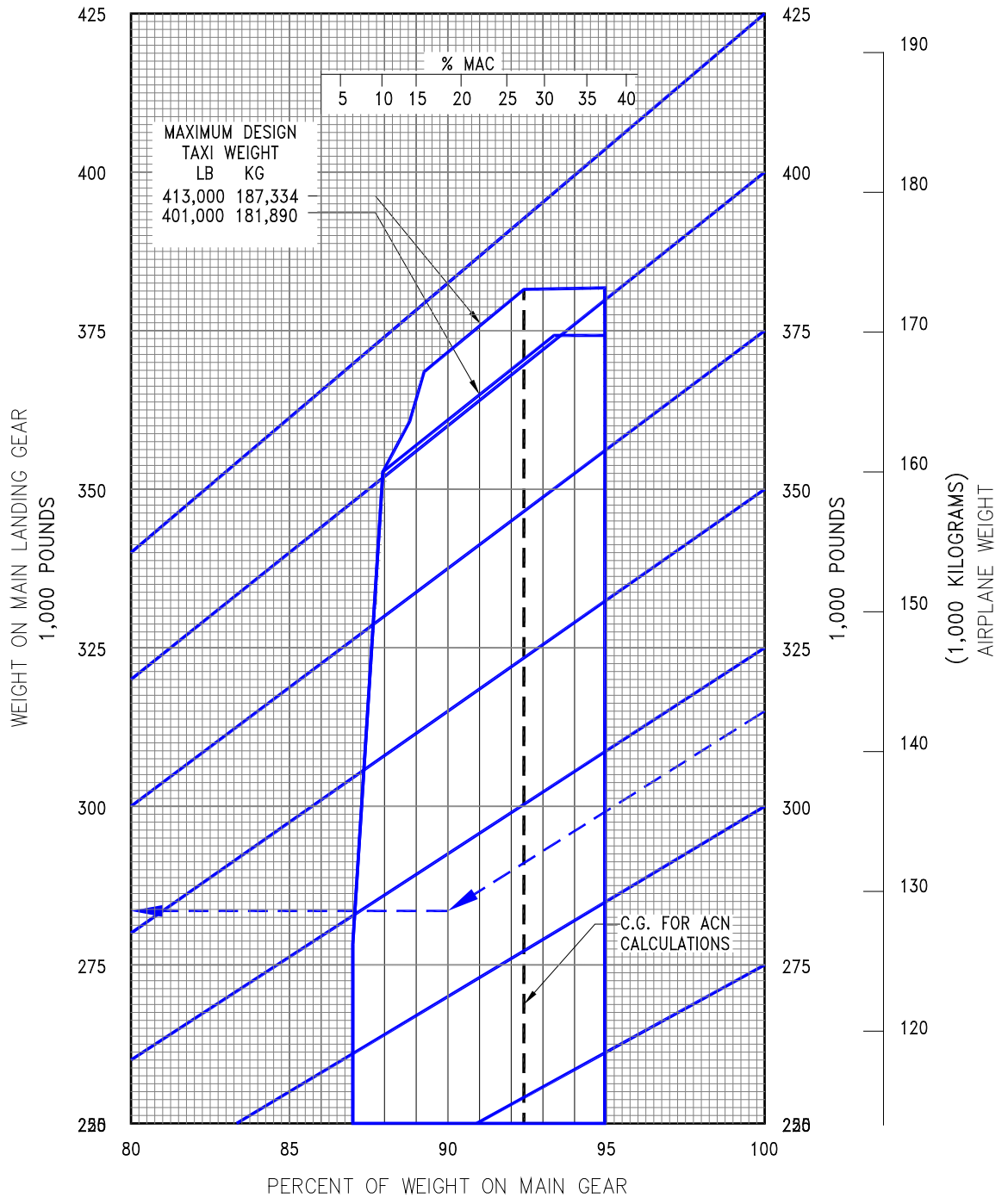

D6-58328

REV I

July 2021

7-11

7.4.5 Landing Gear Loading On Pavement: Model 767-300F

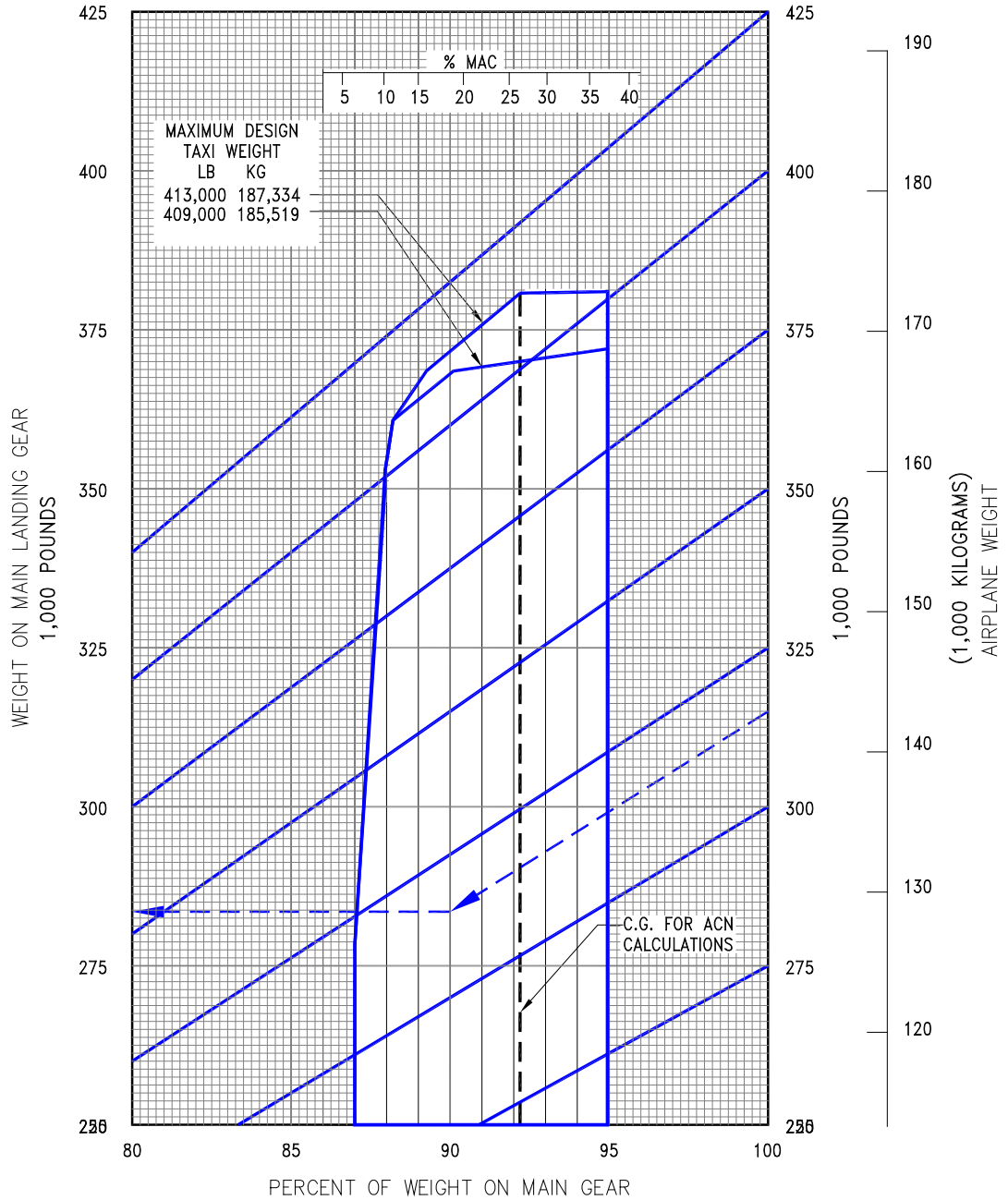

D6-58328

REV I

July 2021

7-12

7.4.6 Landing Gear Loading On Pavement: Model 767-400ER

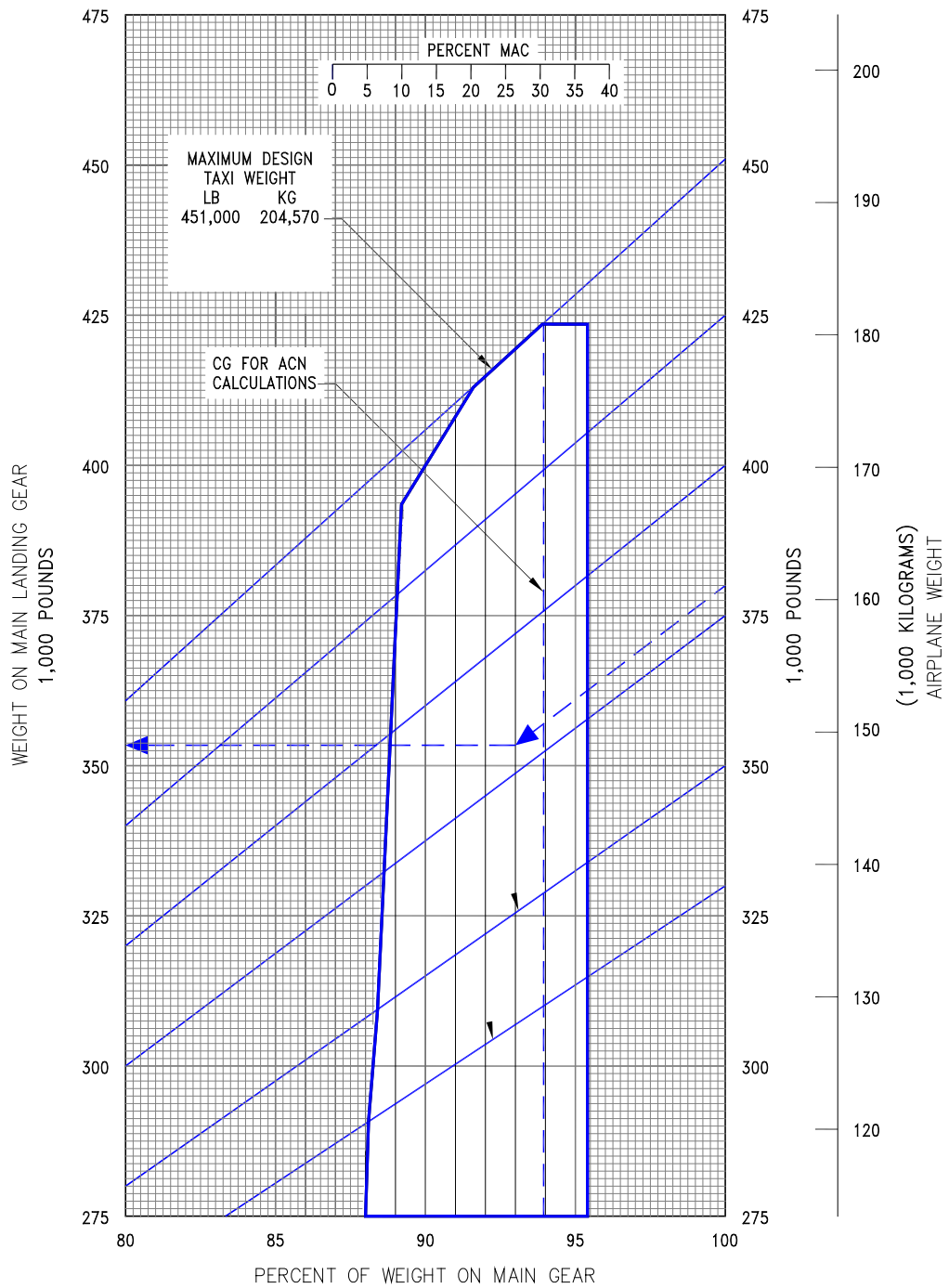

D6-58328

REV I

July 2021

7-13

7.5 FLEXIBLE PAVEMENT REQUIREMENTS - U.S. ARMY CORPS OF ENGINEERS METHOD S-77-1

For the flexible pavement design refer to the FAA AC 150/5320-6F "Airport Pavement Design and Evaluation" and pavement design program FAARFIELD. Both are available on the FAA website:

FAA AC 150/5320-6F: https://www.faa.gov/airports/resources/advisory_circulars/
FAARFIELD: https://www.faa.gov/airports/engineering/design_software/

7.5.1 Flexible Pavement Requirements - U.S. Army Corps of Engineers Design Method (S-77-1): Model 767-200, -200ER, -300, -300ER, -300 Freighter

NOTES: TIRES - H46 X 18-20 - 32PR
 PRESSURE CONSTANT AT 200 PSI (14.06 KG/SQ CM)

CALIFORNIA BEARING RATIO, CBR

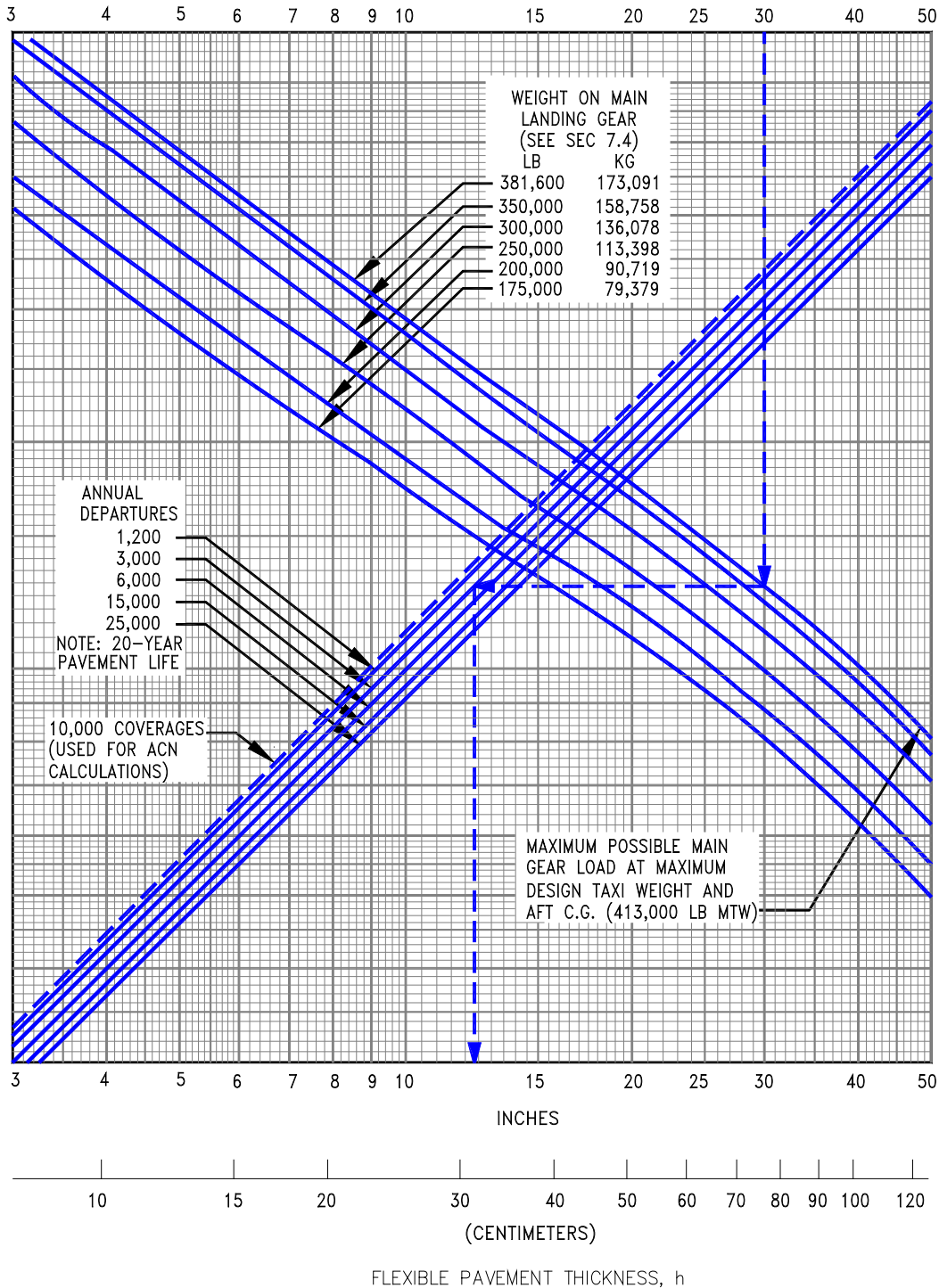

D6-58328

REV I

July 2021

7-15

7.5.2 Flexible Pavement Requirements - U.S. Army Corps of Engineers Design Method (S-77-1): Model 767-400ER

NOTE: TIRES - 50 X 20R22 - 32PR

CALIFORNIA BEARING RATIO, CBR

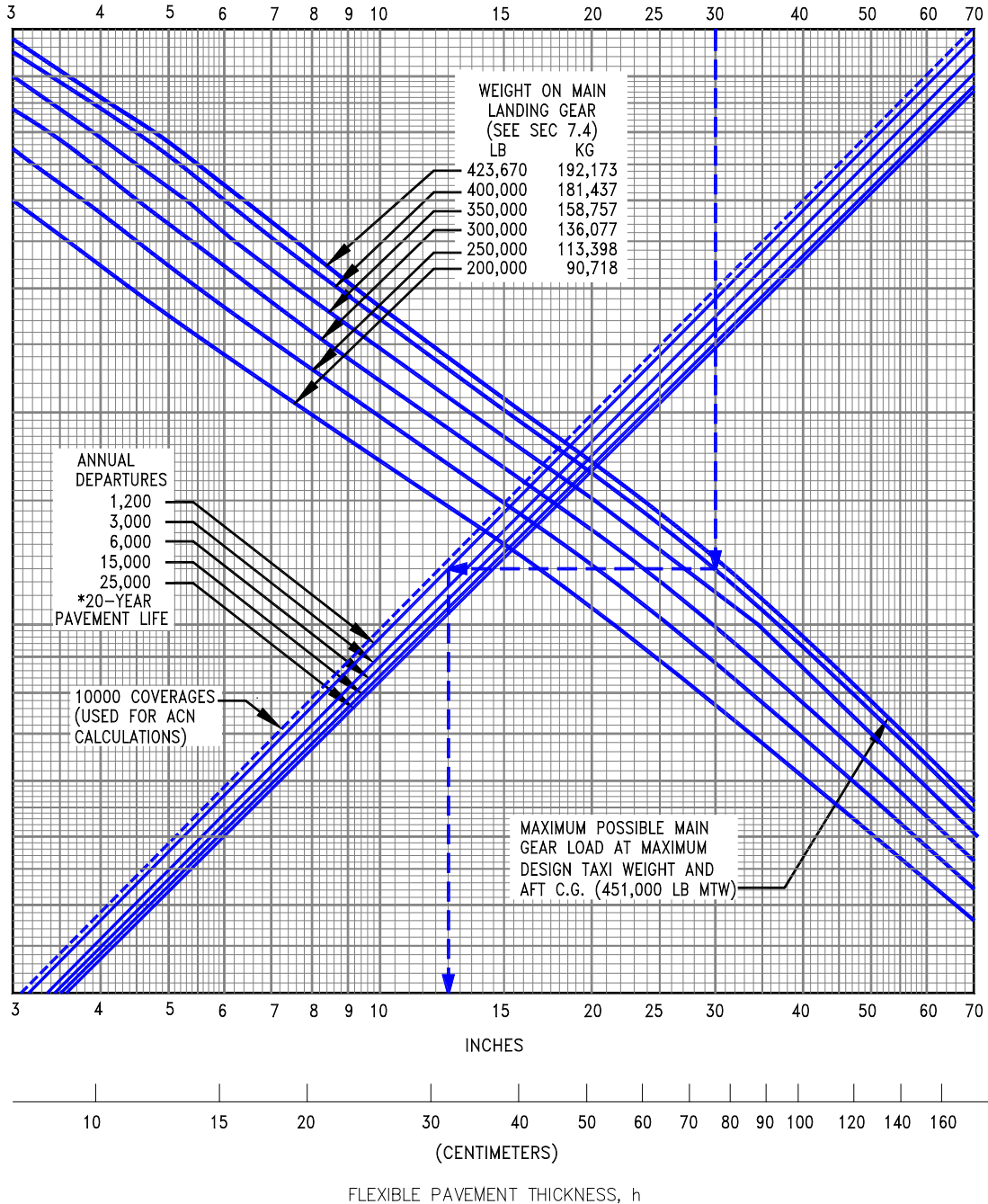

D6-58328

REV I

July 2021

7-16

7.6 FLEXIBLE PAVEMENT REQUIREMENTS - LCN CONVERSION

The Load Classification Number (LCN) curves are no longer provided in section 7.6 and 7.8 since the LCN system for reporting pavement strength is obsolete, being replaced by the ICAO recommended ACN/PCN system in 1983. For questions regarding the LCN system contact Boeing Airport Compatibility Engineering:

AirportCompatibility@boeing.com

7.7 RIGID PAVEMENT REQUIREMENTS - PORTLAND CEMENT ASSOCIATION DESIGN METHOD

The Portland Cement Association method of calculating rigid pavement requirements is based on the computerized version of "Design of Concrete Airport Pavement" (Portland Cement Association, 1955) as described in XP6705-2, "Computer Program for Airport Pavement Design" by Robert G. Packard, Portland Cement Association, 1968.

The following rigid pavement design chart presents the data for six incremental main gear loads at the minimum tire pressure required at the maximum design taxi weight.

In the example shown in 7.7.1, for an allowable working stress of 550 psi, a main gear load of 300,000 lb, and a subgrade strength (k) of 300, the required rigid pavement thickness is 9.4 in.

7.7.1 Rigid Pavement Requirements - Portland Cement Association Design Method: Model 767-200, -200ER, -300, -300ER, -300 Freighter

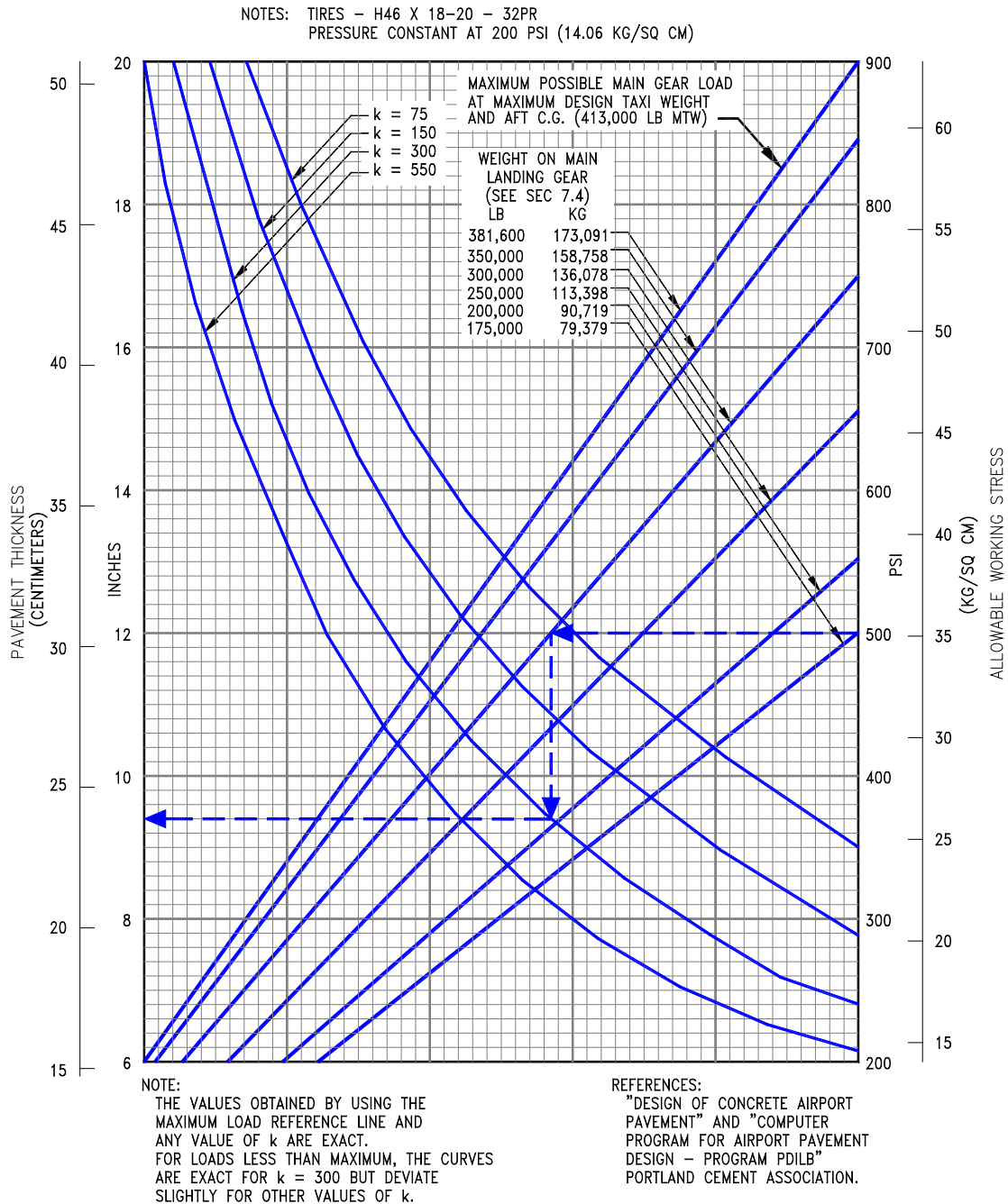

D6-58328

REV I

July 2021

7-19

7.7.2 Rigid Pavement Requirements - Portland Cement Association Design Method: Model 767-400ER

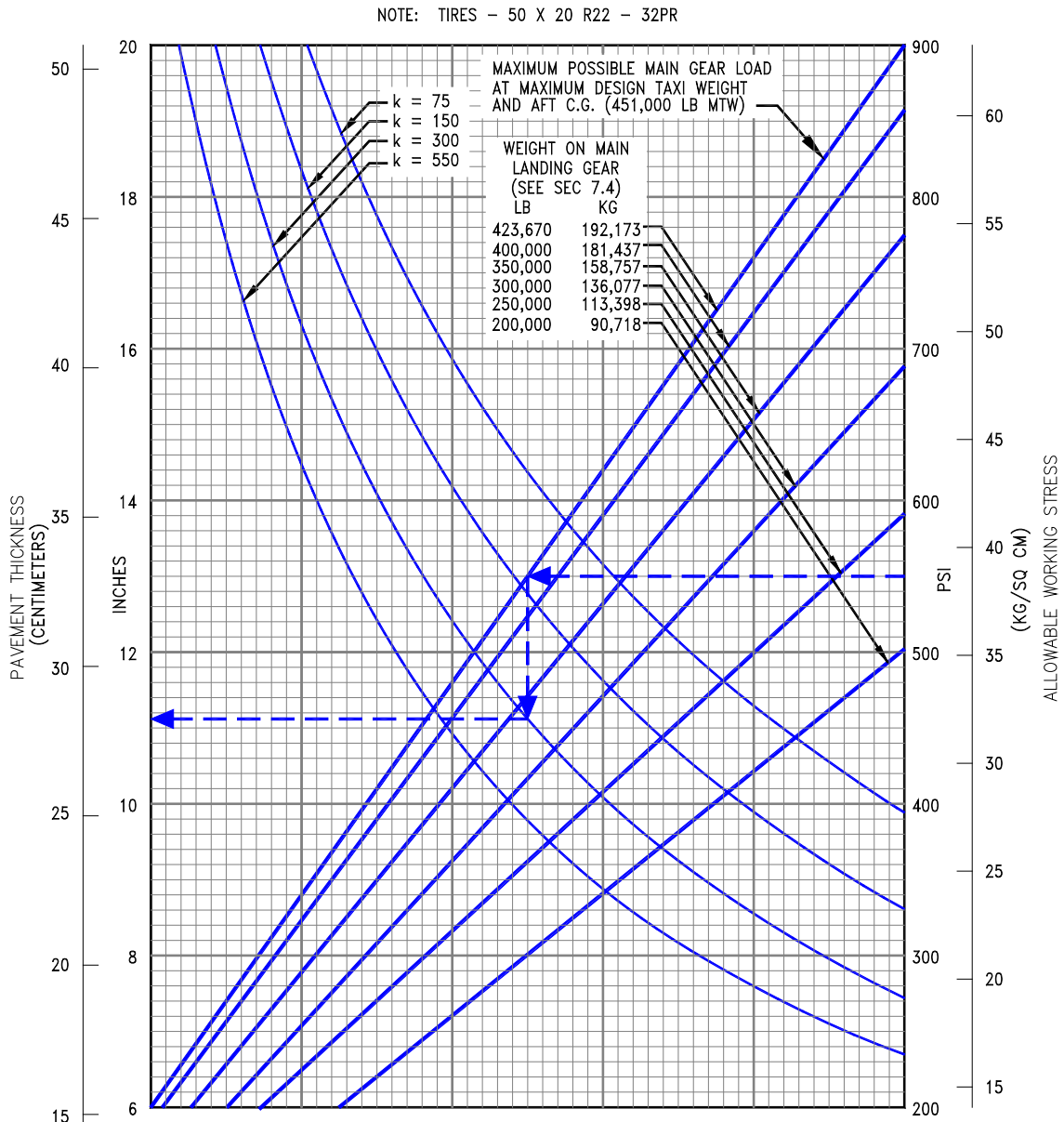

NOTE:
THE VALUES OBTAINED BY USING THE MAXIMUM LOAD REFERENCE LINE AND ANY VALUE OF k ARE EXACT. FOR LOADS LESS THAN MAXIMUM, THE CURVES ARE EXACT FOR $k = 300$ BUT DEVIATE SLIGHTLY FOR OTHER VALUES OF k .

REFERENCES:
"DESIGN OF CONCRETE AIRPORT PAVEMENT" AND "COMPUTER PROGRAM FOR AIRPORT PAVEMENT DESIGN - PROGRAM PDILB"
PORTLAND CEMENT ASSOCIATION.

D6-58328

REV I

July 2021

7-20

7.8 RIGID PAVEMENT REQUIREMENTS - LCN CONVERSION

The Load Classification Number (LCN) curves are no longer provided in section 7.6 and 7.8 since the LCN system for reporting pavement strength is obsolete, being replaced by the ICAO recommended ACN/PCN system in 1983. For questions regarding the LCN system contact Boeing Airport Compatibility Engineering:

AirportCompatibility@boeing.com

7.9 RIGID PAVEMENT REQUIREMENTS - FAA DESIGN METHOD

For the rigid pavement design refer to the FAA AC 150/5320-6F “Airport Pavement Design and Evaluation” and pavement design program FAARFIELD. Both are available on the FAA website:

FAA AC 150/5320-6F: https://www.faa.gov/airports/resources/advisory_circulars/

FAARFIELD: https://www.faa.gov/airports/engineering/design_software/

7.10 ACN/PCN REPORTING SYSTEM - FLEXIBLE AND RIGID PAVEMENTS

To determine the ACN of an aircraft on flexible or rigid pavement, both the aircraft gross weight and the subgrade strength category must be known. In the chart in 7.10.1, for an aircraft with gross weight of 260,000 lb on a low subgrade strength (Code C), the flexible pavement ACN is 27.0. Referring to 7.10.6, the same aircraft, the same gross weight, and on a low subgrade rigid pavement has an ACN of 30.0.

Note: An aircraft with an ACN equal to or less than the reported PCN can operate on that pavement subject to any limitations on the tire pressure. (Ref.: Amendment 35 to ICAO Annex 14 Aerodrome, Eighth Edition, March 1983.)

The following table provides ACN data in tabular format similar to the one used by ICAO in the “Aerodrome Design Manual Part 3, Pavements.” If the ACN for an intermediate weight between the maximum taxi weight and minimum weight specified in the table is required, Figures 7.10.1 through 7.10.10 should be consulted. ACN data in the table is provided for the most common weights of a particular aircraft model.

AIRCRAFT TYPE	MAXIMUM TAXI WEIGHT MINIMUM WEIGHT (1) LB (KG)	LOAD ON ONE MAIN GEAR LEG (%)	TIRE PRESSURE psi (Mpa)	ACN FOR RIGID PAVEMENT SUBGRADES pci (MN/m ³)				ACN FOR FLEXIBLE PAVEMENT SUBGRADES CBR			
				HIGH 550 (150)	MEDIUM 300 (80)	LOW 150 (40)	ULTRA LOW 75 (20)	HIGH 15	MEDIUM 10	LOW 6	ULTRA LOW 3
767-200	317,000 (143,787)	45.75	182 (1.25)	32	38	45	53	34	37	43	60
	176,650 (80,127)			16	18	21	24	17	18	20	25
767-200ER	396,000 (179,623)	45.40	190 (1.31)	43	52	62	71	45	50	60	80
	181,610 (82,377)			17	19	21	25	17	18	20	25
767-300	352,000 (159,665)	47.47	186 (1.28)	39	47	58	64	41	45	53	73
	189,750 (86,069)			19	21	24	28	19	20	23	29
767-300ER 737-300F	413,000 (187,334)	46.20	200 (1.38)	48	57	68	78	49	54	66	87
	198,440 (90,011)			19	22	25	29	20	21	23	30
767-400ER	451,000 (204,750)	46.95	213 (1.47)	58	69	81	92	57	63	79	100
	229,000 (103,872)			24	27	32	37	24	26	29	39

(1) Minimum weight used solely as a baseline for ACN curve generation.

7.10.1 Aircraft Classification Number - Flexible Pavement: Model 767-200

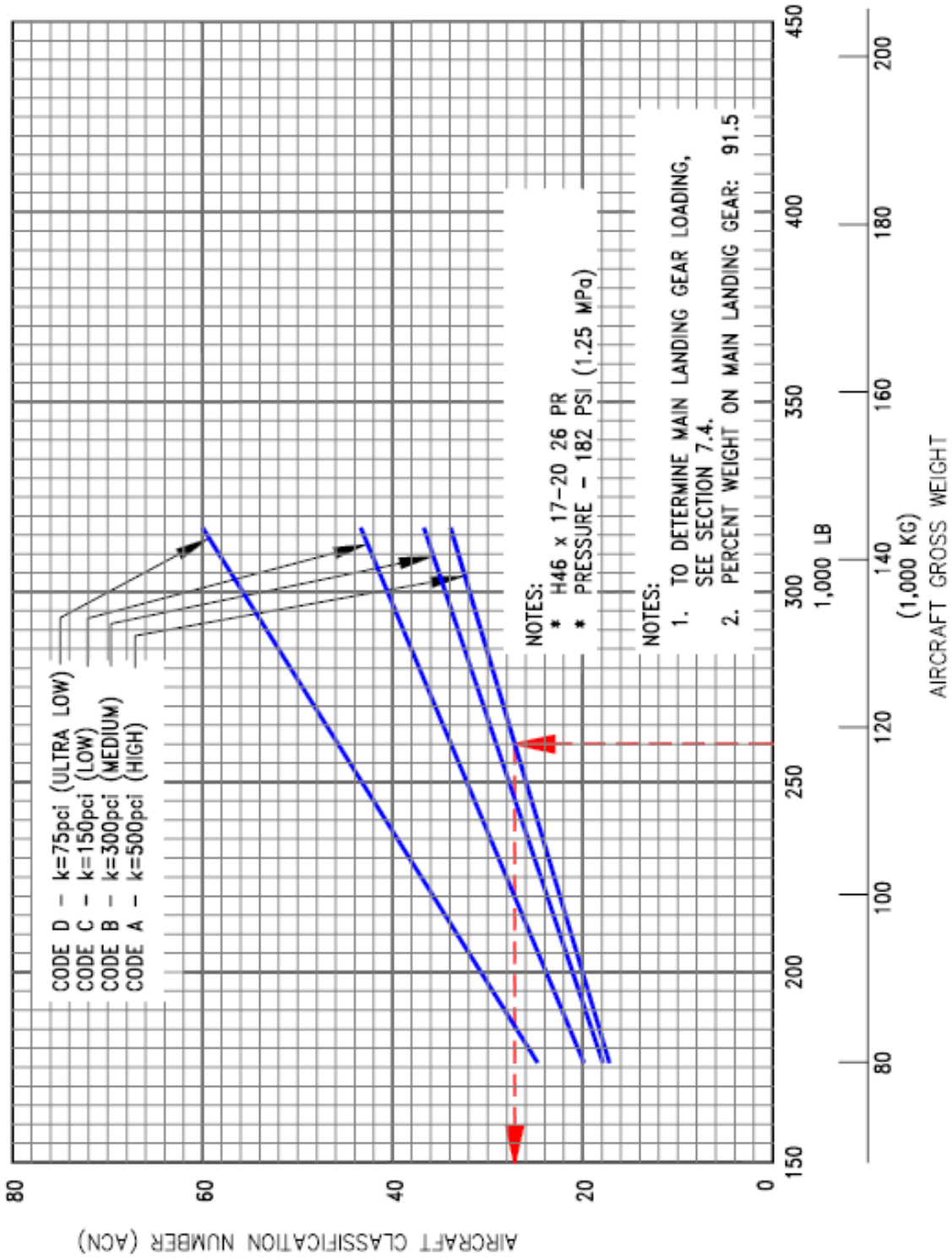

7.10.2 Aircraft Classification Number - Flexible Pavement: Model 767-200ER

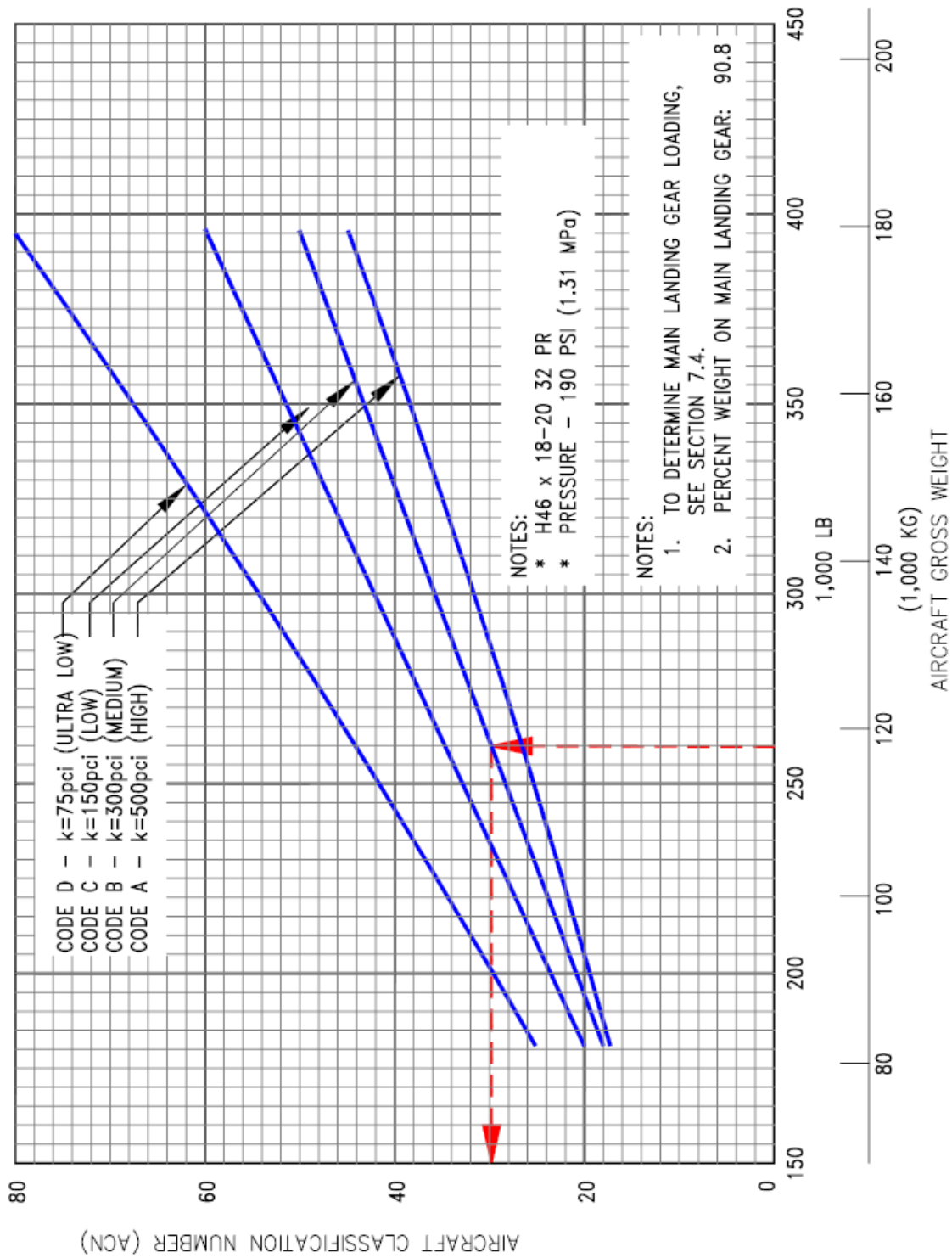

D6-58328

REV I

July 2021

7-25

7.10.3 Aircraft Classification Number - Flexible Pavement: Model 767-300

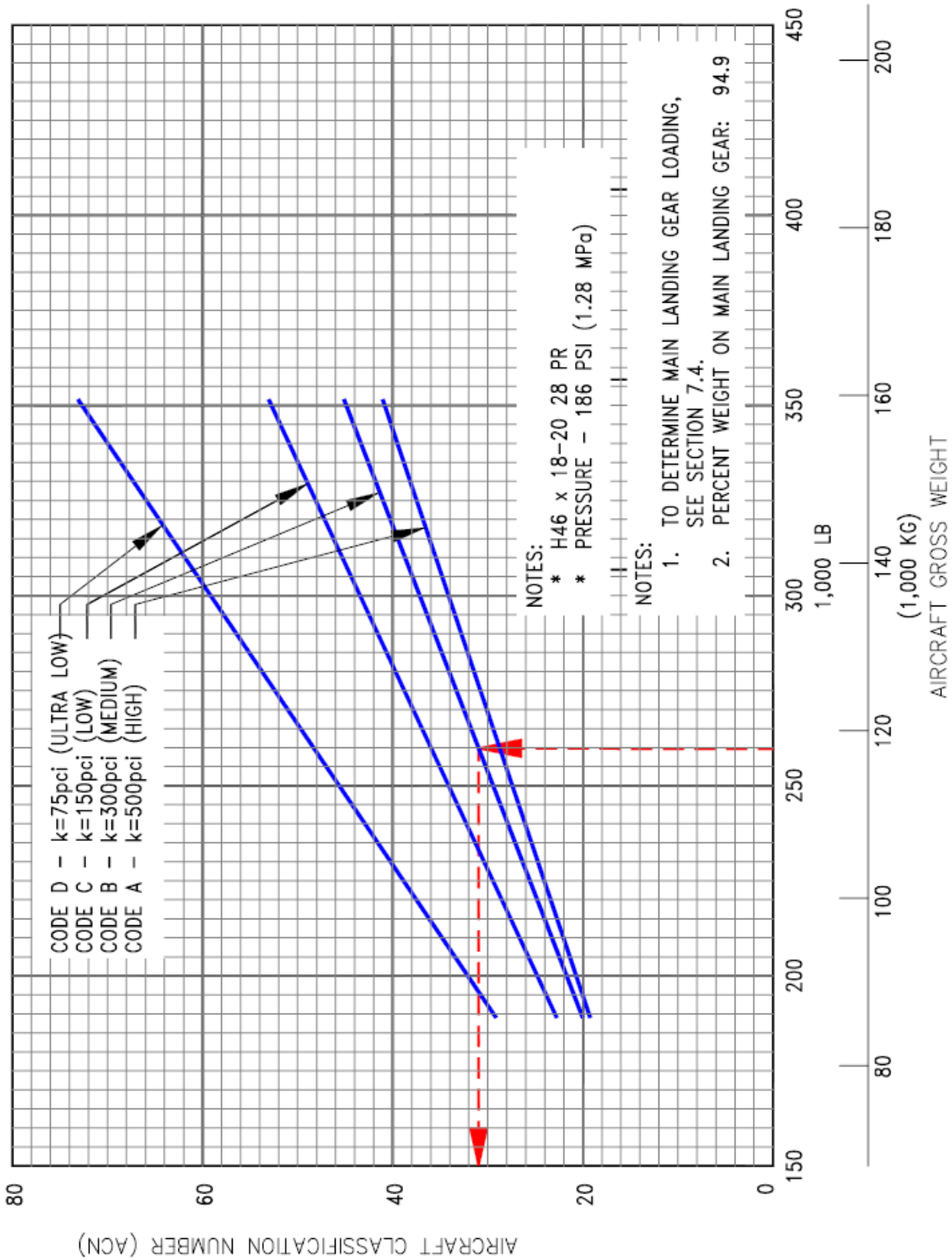

D6-58328

REV I

July 2021

7-26

7.10.4 Aircraft Classification Number - Flexible Pavement: Model 767-300ER, -300 Freighter

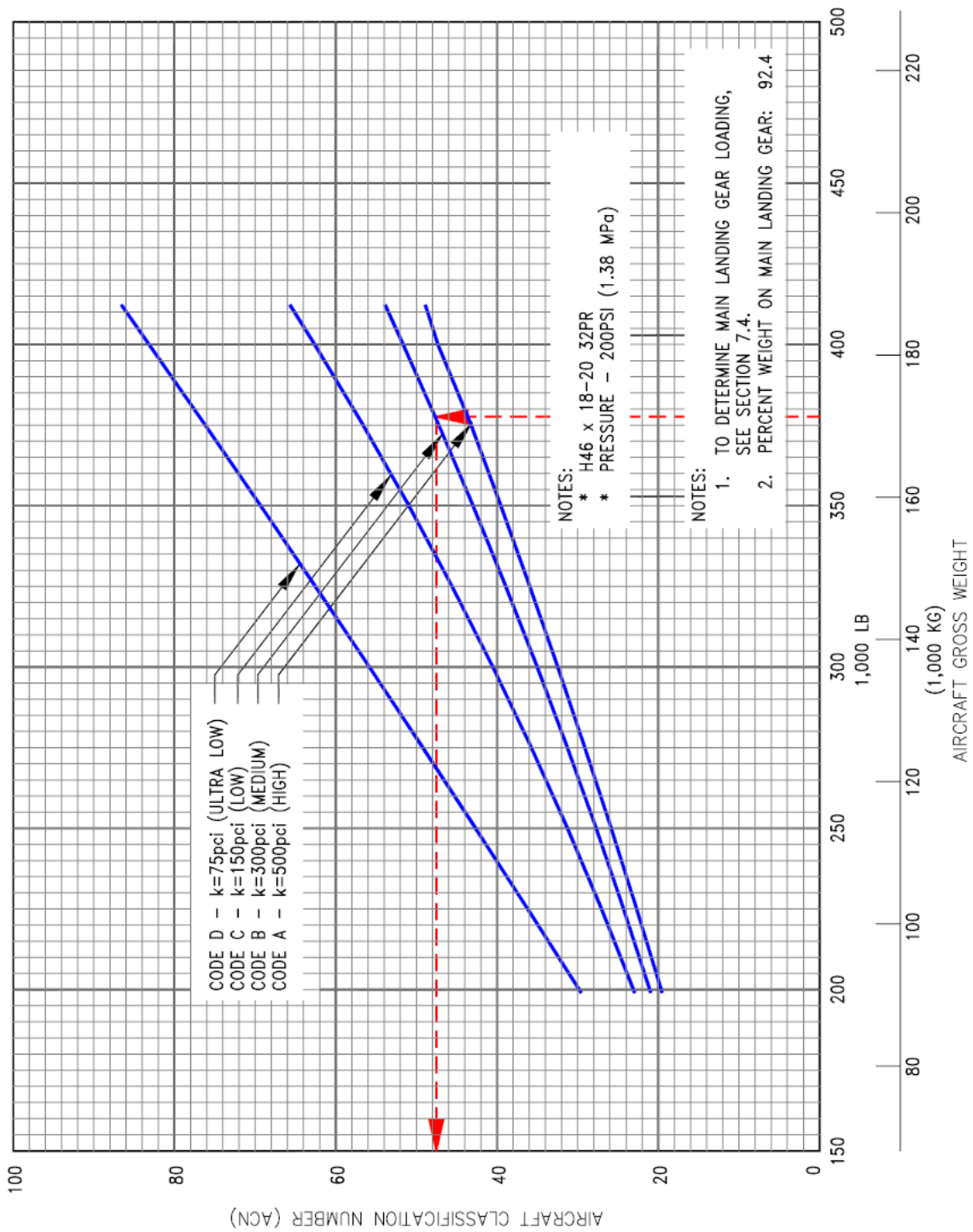

D6-58328

July 2021

REV I

7-27

7.10.5 Aircraft Classification Number - Flexible Pavement: Model 767-400ER

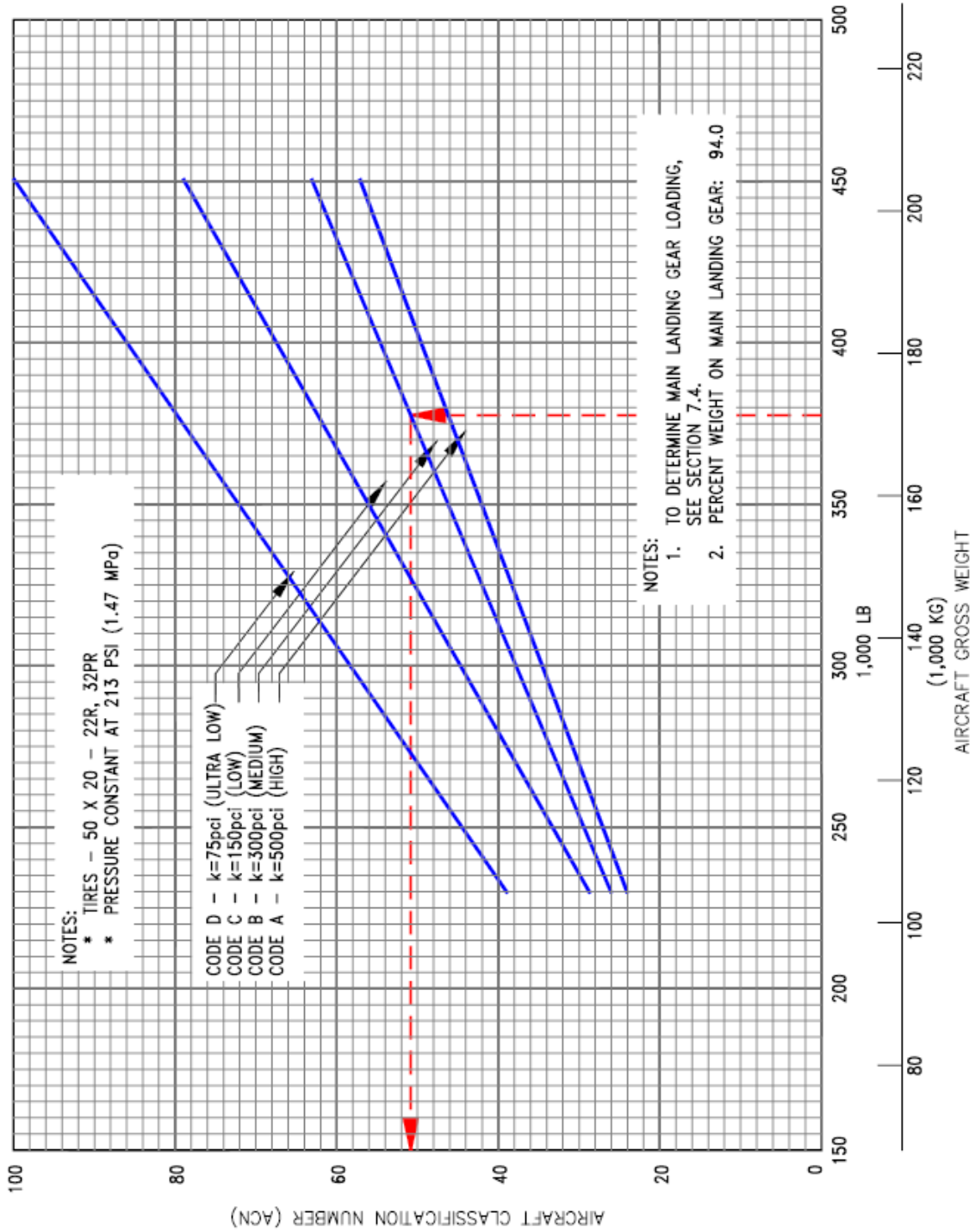

D6-58328

REV I

July 2021

7-28

7.10.6 Aircraft Classification Number - Rigid Pavement: Model 767-200

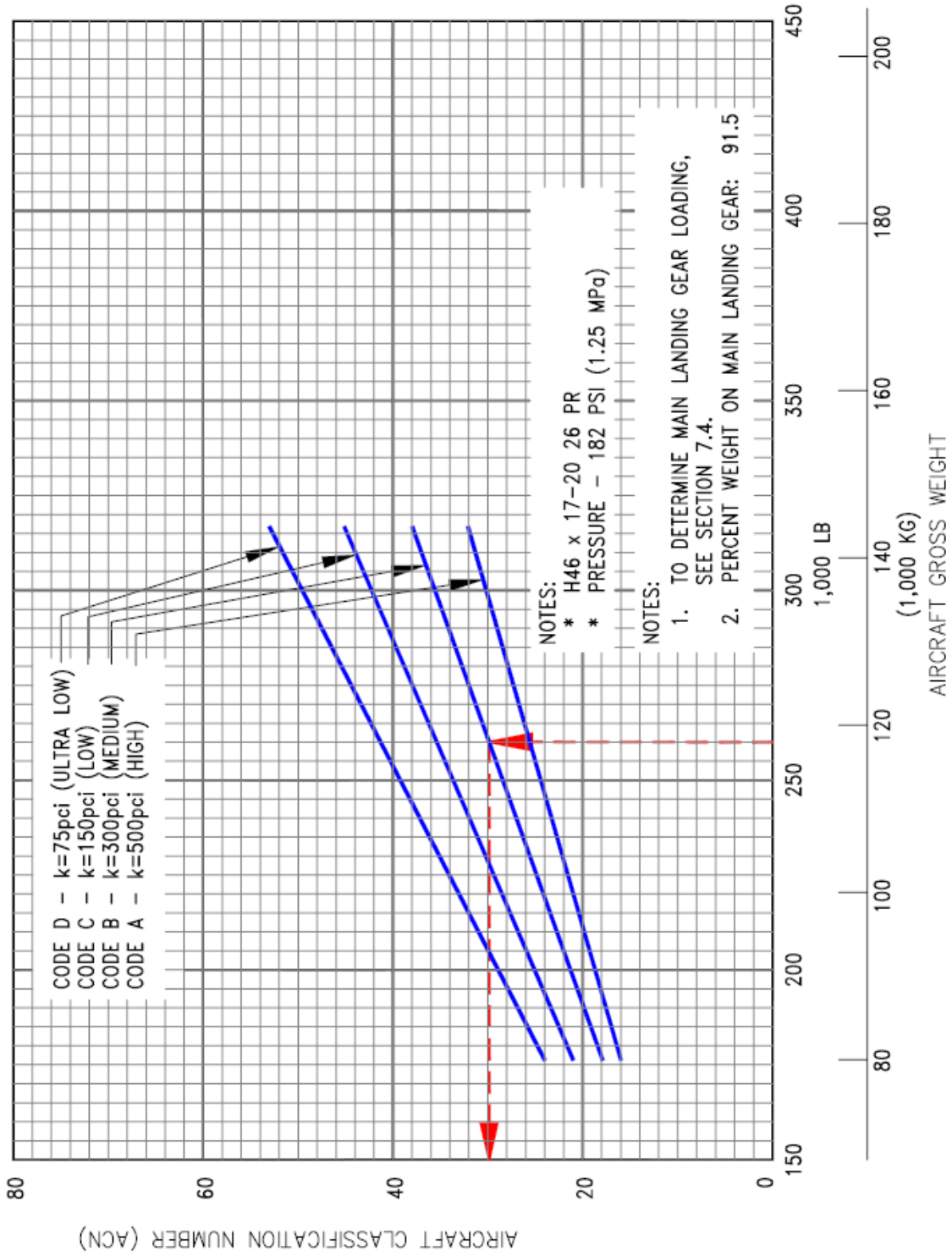

D6-58328

REV I

July 2021

7-29

7.10.7 Aircraft Classification Number - Rigid Pavement: Model 767-200ER

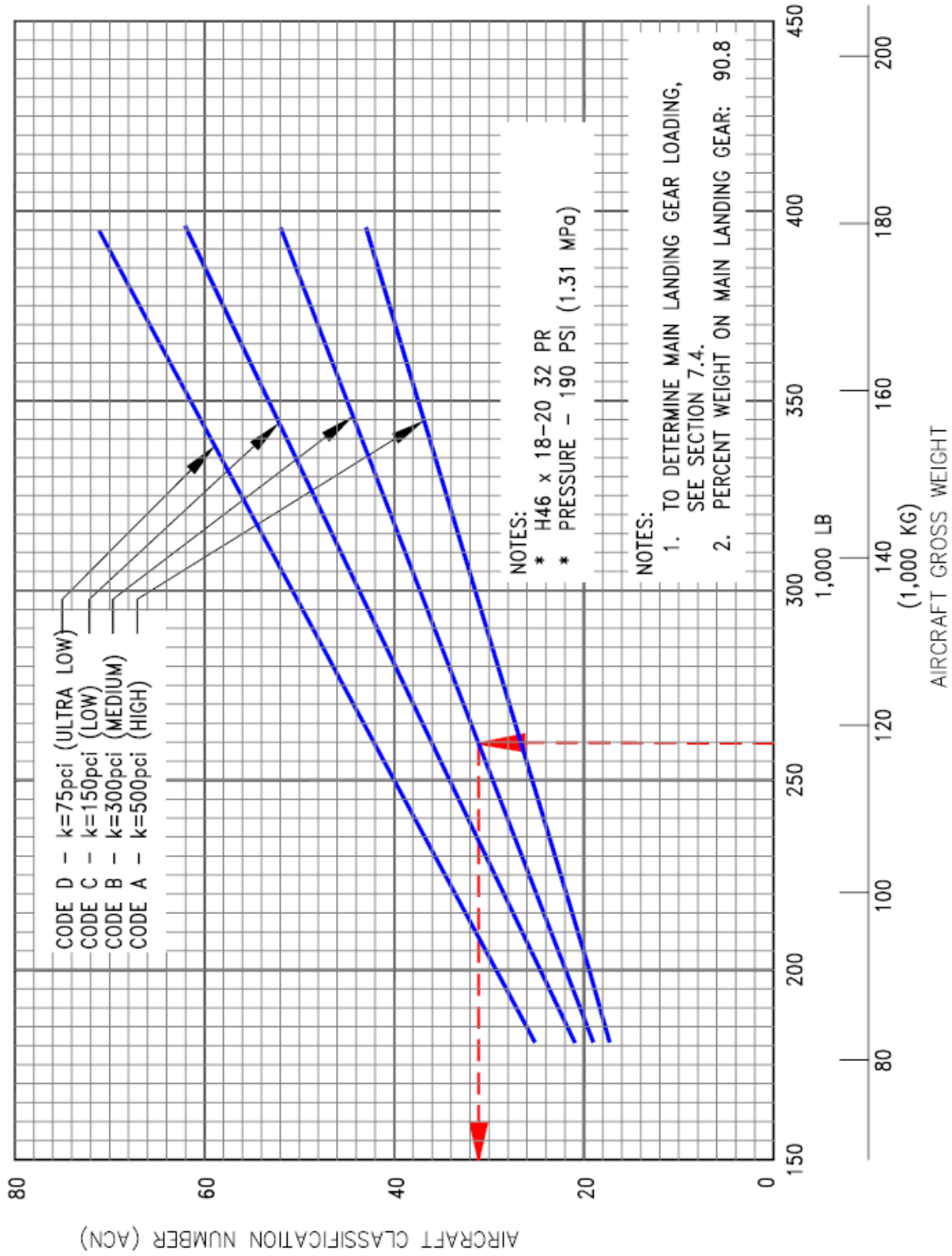

7.10.8 Aircraft Classification Number - Rigid Pavement: Model 767-300

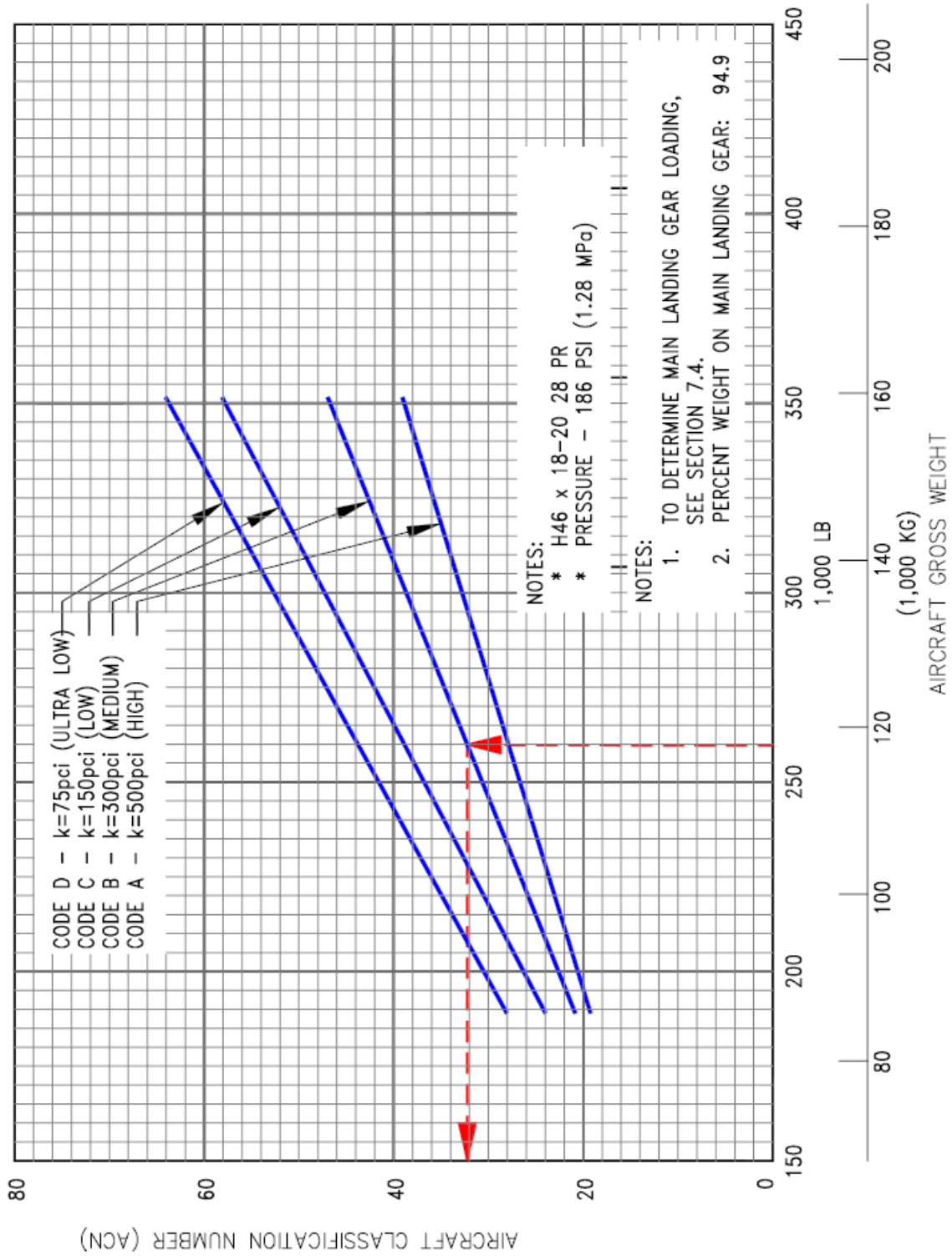

7.10.9 Aircraft Classification Number - Rigid Pavement: Model 767-300ER, -300 Freighter

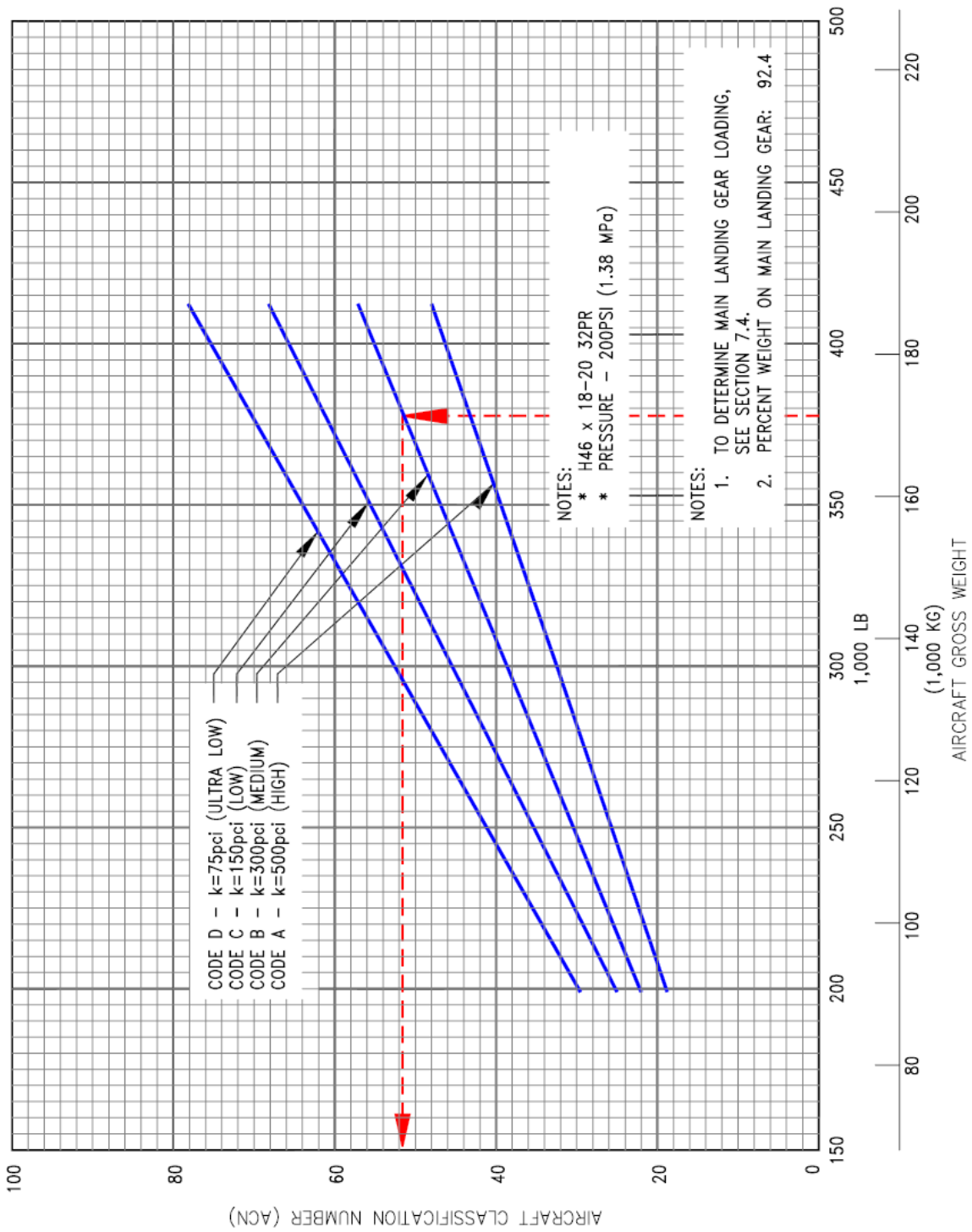

D6-58328

July 2021

REV I

7-32

7.10.10 Aircraft Classification Number - Rigid Pavement: Model 767-400ER

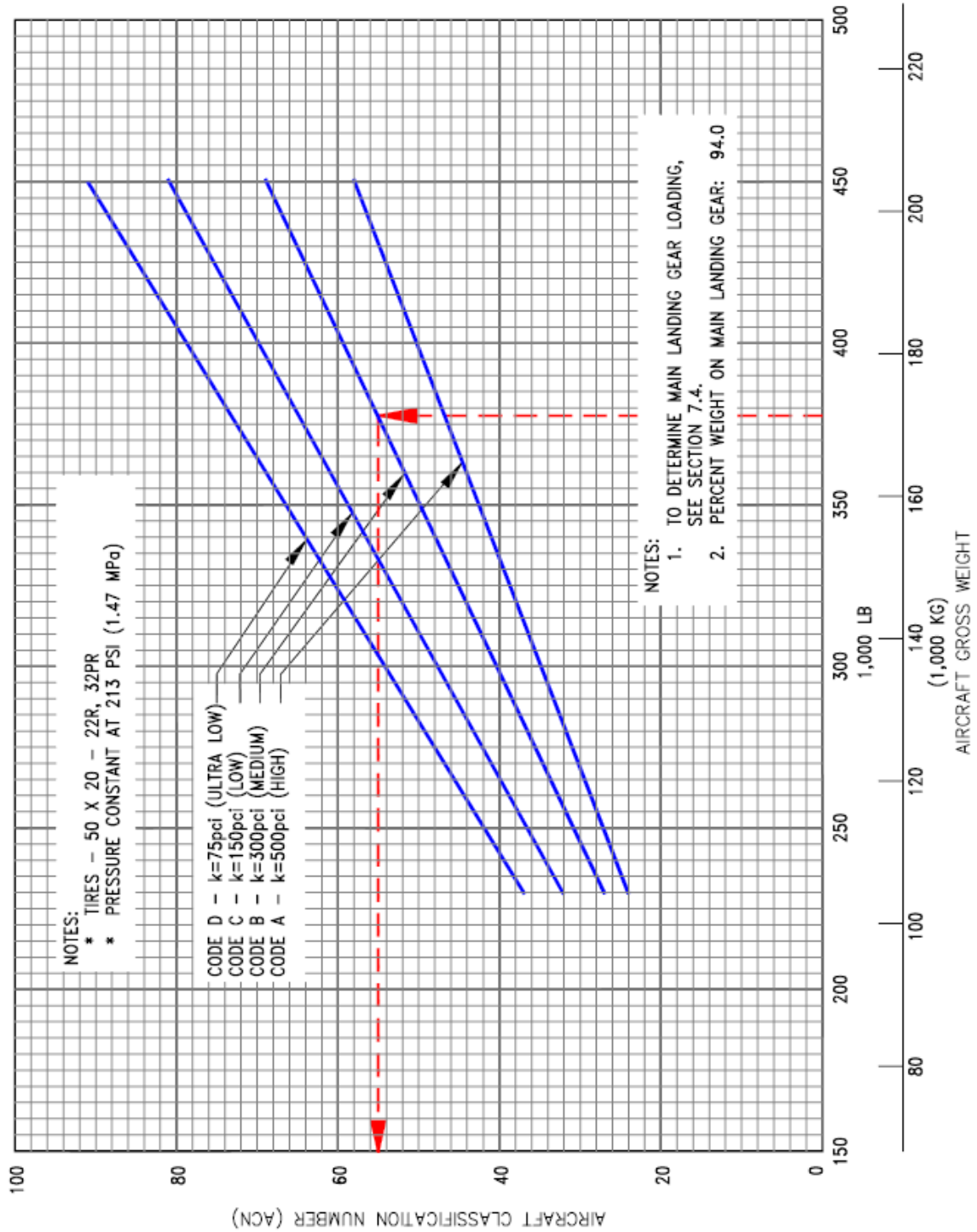

D6-58328

July 2021

REV I

7-33

8.0 FUTURE 767 DERIVATIVE AIRPLANES

Several derivatives are being studied to provide additional capabilities of the 767 family of airplanes. Future growth versions could require additional passenger or cargo capacity or increased range or both. Whether these growth versions could be built would depend entirely on airline requirements. In any event, impact on airport facilities will be a consideration in the configuration and design.

9.0 SCALED 767 DRAWINGS

The drawings in the following pages show airplane plan view drawings, drawn to approximate scale as noted. The drawings may not come out to exact scale when printed or copied from this document. Printing scale should be adjusted when attempting to reproduce these drawings. Three-view drawing files of the 767-200, -200ER, -300, -300ER, -300 Freighter, -400ER, along with other Boeing airplane models, can be downloaded from the following website:

<http://www.boeing.com/airports>

9.1 MODEL 767-200, -200ER

9.1.1 Scaled Drawings – 1 IN. = 32 FT: Model 767-200, -200ER

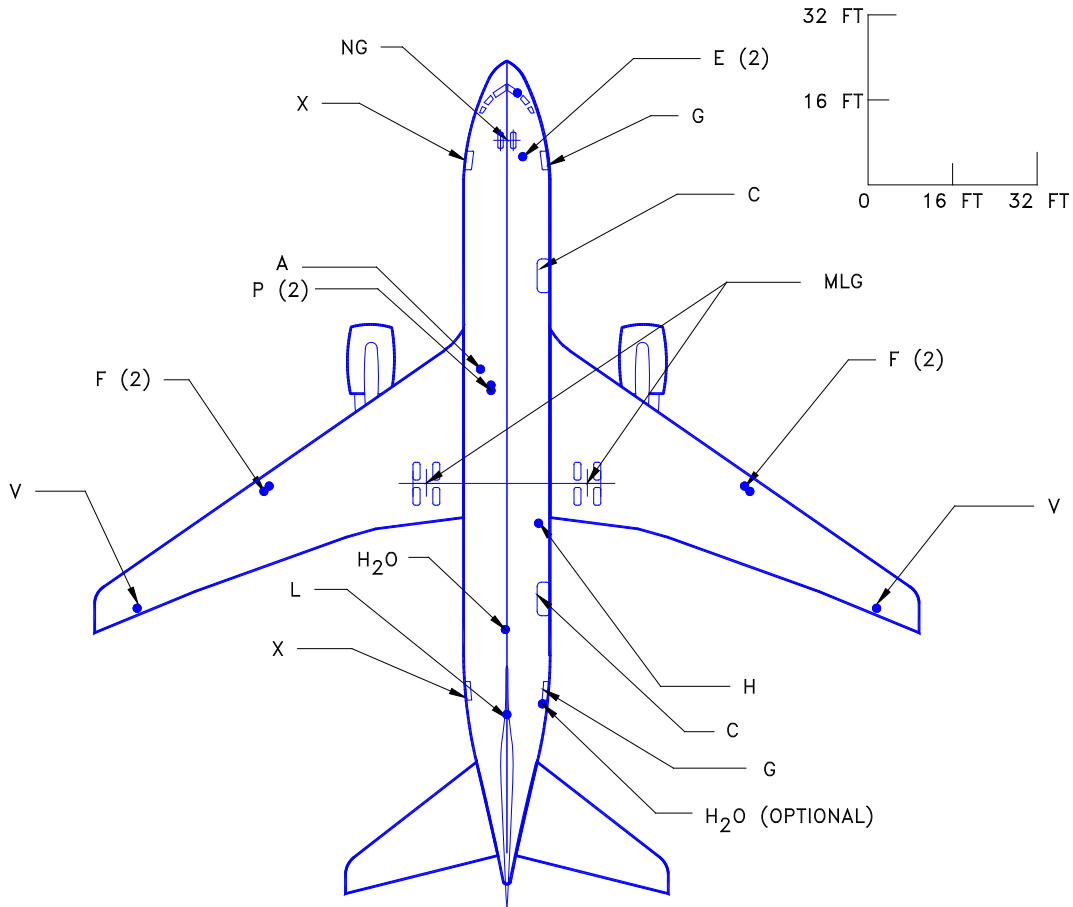

LEGEND

- A CONDITIONED AIR
- C CARGO DOOR
- E ELECTRICAL
- F FUEL
- G GALLEY SERVICE DOOR
- H HYDRAULIC
- H₂O POTABLE WATER
- L LAVATORY
- MLG MAIN LANDING GEAR
- NG NOSE GEAR
- P PNEUMATIC
- V FUEL VENT
- X PASSENGER DOOR

NOTE: FOR TURNING RADIUS DATA
SEE SECTIONS 4.2 AND 4.3

NOTE: ADJUST FOR PROPER SCALING WHEN PRINTING THIS PAGE

9.1.2 Scaled Drawings – 1 IN. = 32 FT: Model 767-200, -200ER

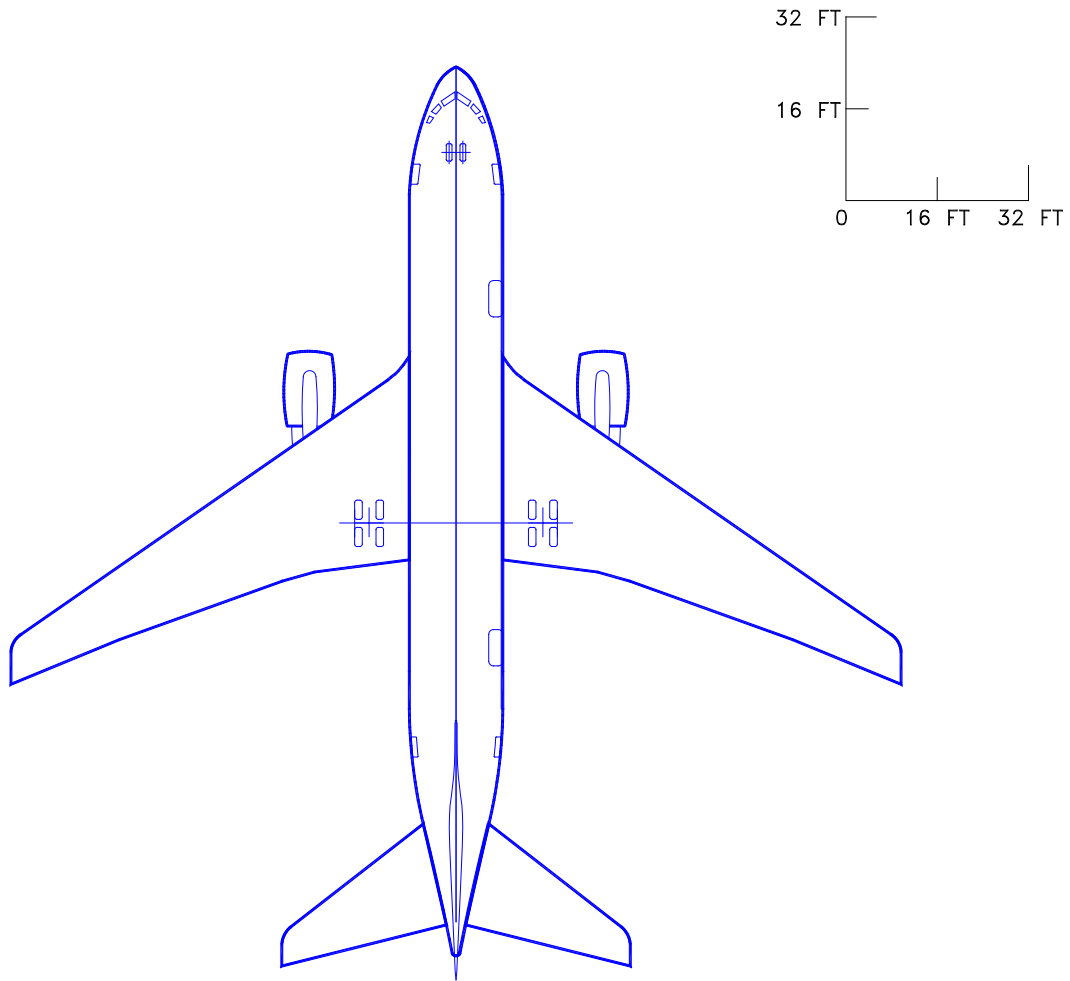

NOTE: ADJUST FOR PROPER SCALING WHEN PRINTING THIS PAGE

9.1.3 Scaled Drawings – 1 IN. = 50 FT: Model 767-200, -200ER

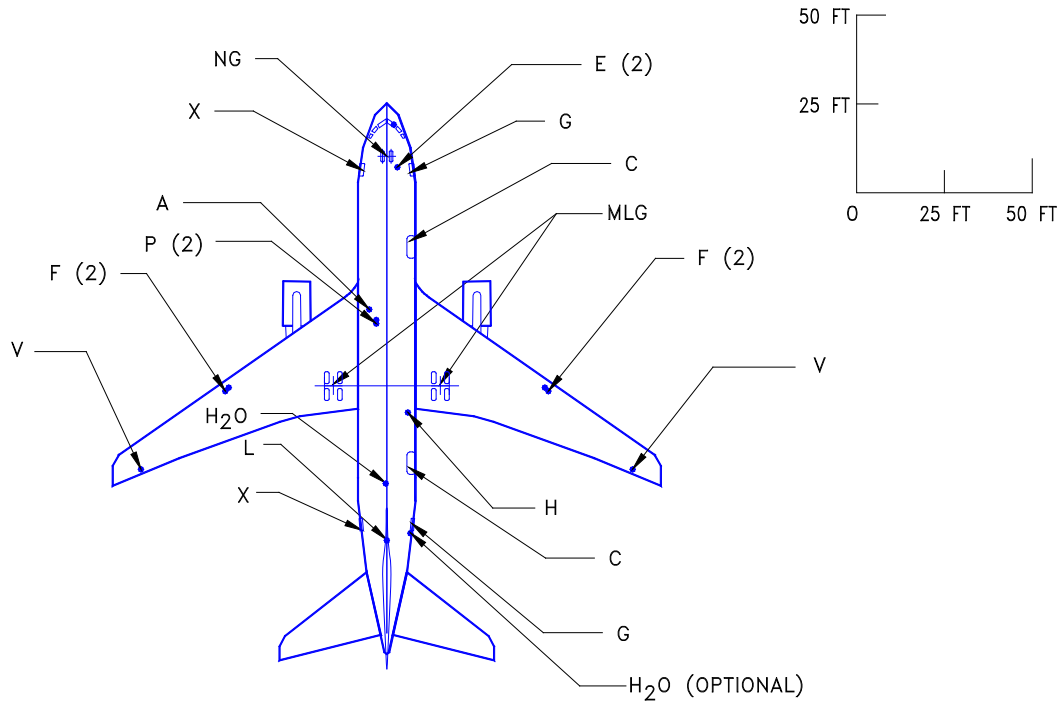

LEGEND

- A CONDITIONED AIR
- C CARGO DOOR
- E ELECTRICAL
- F FUEL
- G GALLEY SERVICE DOOR
- H HYDRAULIC
- H₂O POTABLE WATER
- L LAVATORY
- MLG MAIN LANDING GEAR
- NG NOSE GEAR
- P PNEUMATIC
- V FUEL VENT
- X PASSENGER DOOR

NOTE: FOR TURNING RADIUS DATA
SEE SECTIONS 4.2 AND 4.3

NOTE: ADJUST FOR PROPER SCALING WHEN PRINTING THIS PAGE

9.1.4 Scaled Drawings – 1 IN. = 50 FT: Model 767-200, -200ER

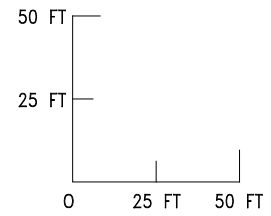
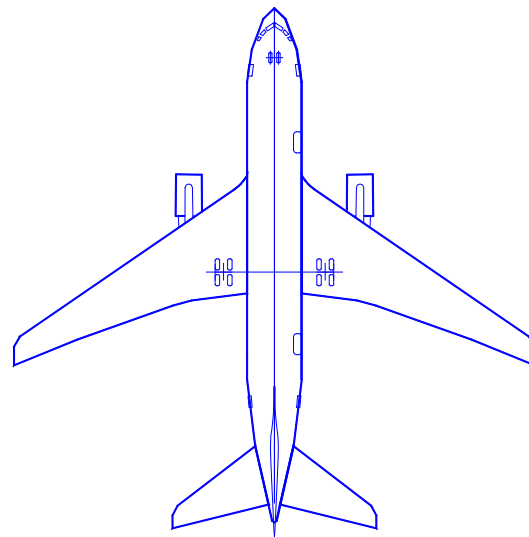

NOTE: ADJUST FOR PROPER SCALING WHEN PRINTING THIS PAGE

9.1.5 Scaled Drawings – 1 IN. = 100 FT: Model 767-200, -200ER

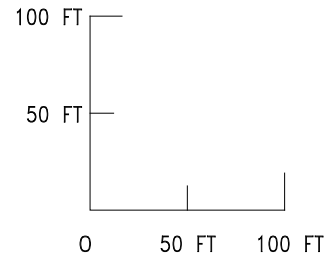
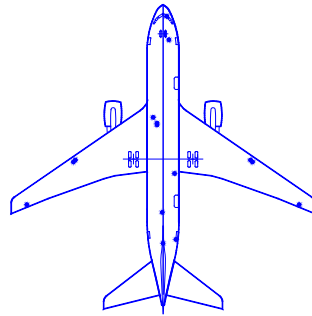

NOTE:

SEE SEC 9.1.1
LOCATIONS AND IDENTIFICATIONS
OF SERVICE POINTS

LEGEND

A CONDITIONED AIR
C CARGO DOOR
E ELECTRICAL
F FUEL
G GALLEY SERVICE DOOR
H HYDRAULIC
H₂O POTABLE WATER
L LAVATORY
MLG MAIN LANDING GEAR
NG NOSE GEAR
P PNEUMATIC
V FUEL VENT
X PASSENGER DOOR

NOTE: FOR TURNING RADIUS DATA
SEE SECTIONS 4.2 AND 4.3

NOTE: ADJUST FOR PROPER SCALING WHEN PRINTING THIS PAGE

9.1.6 Scaled Drawings – 1 IN. = 100 FT: Model 767-200, -200ER

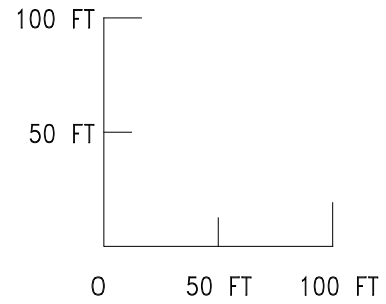
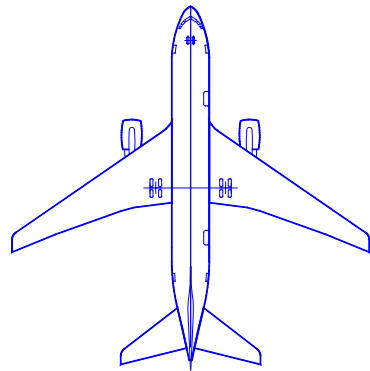

NOTE: ADJUST FOR PROPER SCALING WHEN PRINTING THIS PAGE

9.1.7 Scaled Drawings – 1:500: Model 767-200, -200ER

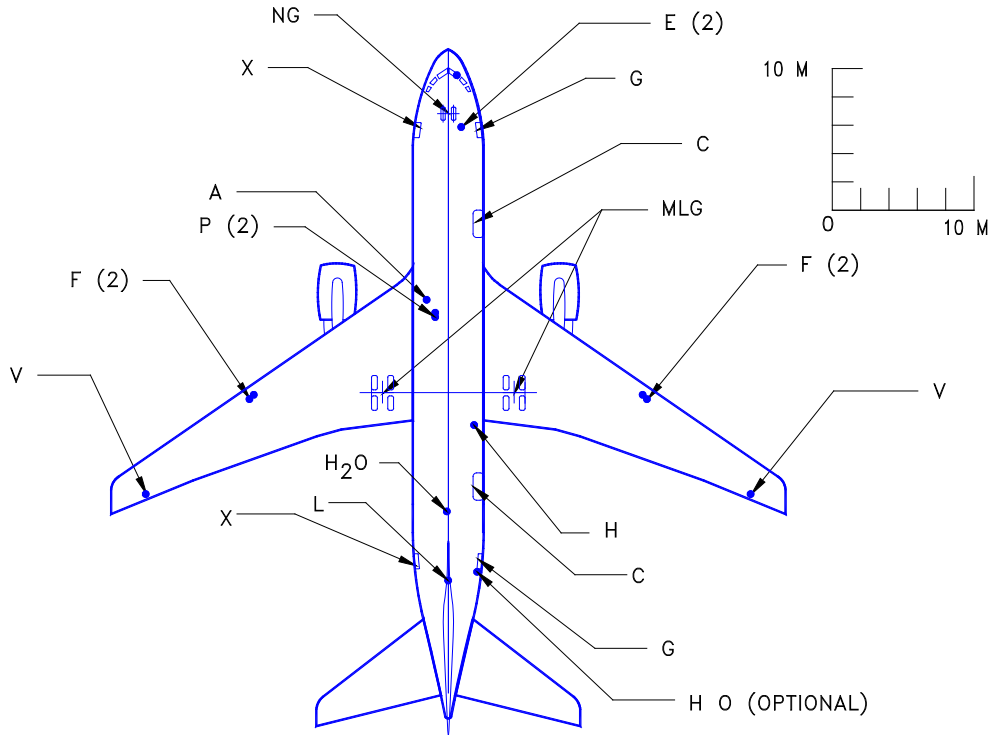

LEGEND

A	CONDITIONED AIR
C	CARGO DOOR
E	ELECTRICAL
F	FUEL
G	GALLEY SERVICE DOOR
H	HYDRAULIC
H ₂ O	POTABLE WATER
L	LAVATORY
MLG	MAIN LANDING GEAR
NG	NOSE GEAR
P	PNEUMATIC
V	FUEL VENT
X	PASSENGER DOOR

NOTE: FOR TURNING RADIUS DATA
SEE SECTIONS 4.2 AND 4.3

NOTE: ADJUST FOR PROPER SCALING WHEN PRINTING THIS PAGE

D6-58328

REV I

July 2021

9-8

9.1.8 Scaled Drawings – 1:500: Model 767-200, -200ER

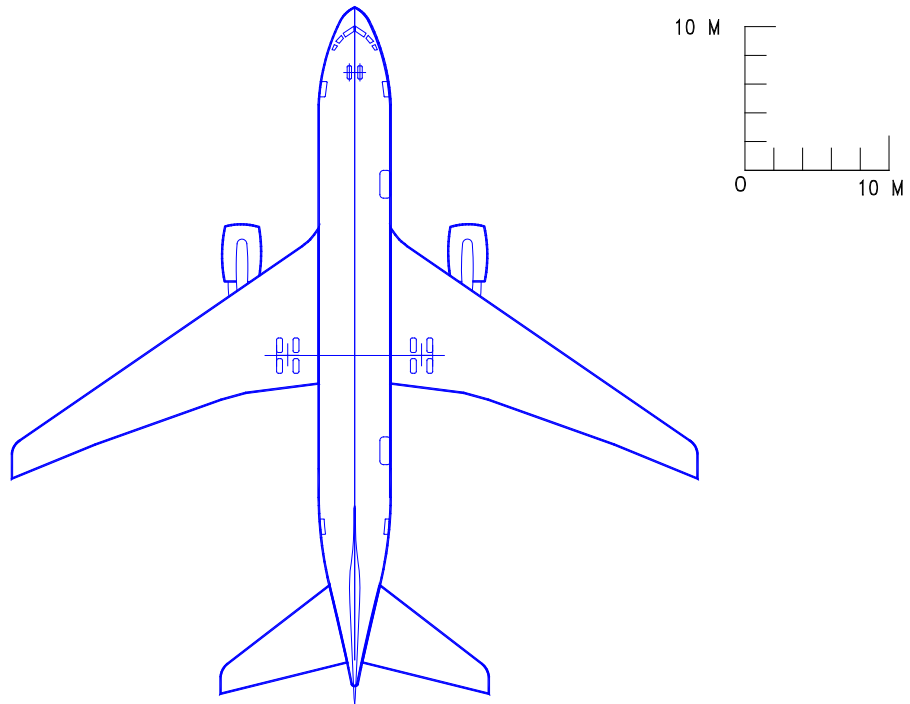

NOTE: ADJUST FOR PROPER SCALING WHEN PRINTING THIS PAGE

9.1.9 Scaled Drawings – 1:1000: Model 767-200, -200ER

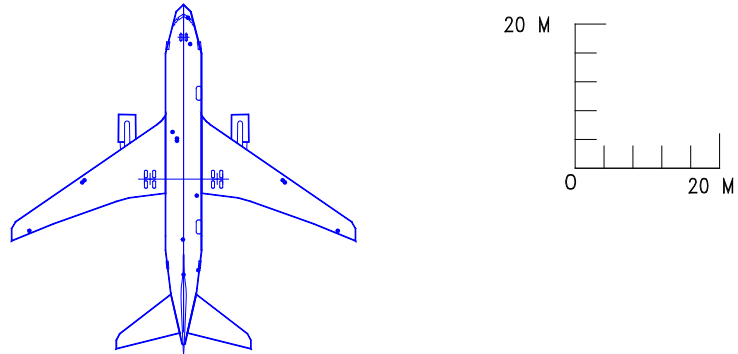

NOTE:

SEE SEC 9.1.1
LOCATIONS AND IDENTIFICATIONS
OF SERVICE POINTS

LEGEND

A CONDITIONED AIR
C CARGO DOOR
E ELECTRICAL
F FUEL
G GALLEY SERVICE DOOR
H HYDRAULIC
H₂O POTABLE WATER
L LAVATORY
MLG MAIN LANDING GEAR
NG NOSE GEAR
P PNEUMATIC
V FUEL VENT
X PASSENGER DOOR

NOTE: FOR TURNING RADIUS DATA
SEE SECTIONS 4.2 AND 4.3

NOTE: ADJUST FOR PROPER SCALING WHEN PRINTING THIS PAGE

D6-58328

REV I

July 2021

9-10

9.1.10 Scaled Drawings – 1:1000: Model 767-200, -200ER

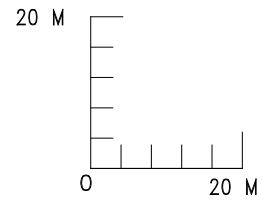
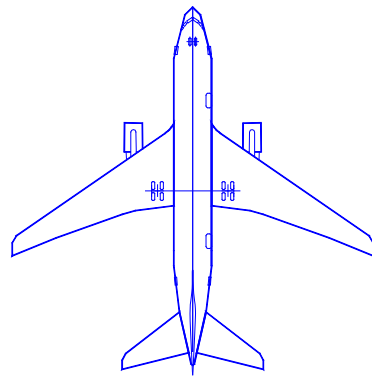

NOTE: ADJUST FOR PROPER SCALING WHEN PRINTING THIS PAGE

9.2 MODEL 767-300, -300ER

9.2.1 Scaled Drawings – 1 IN. = 32 FT: Model 767-300, -300ER

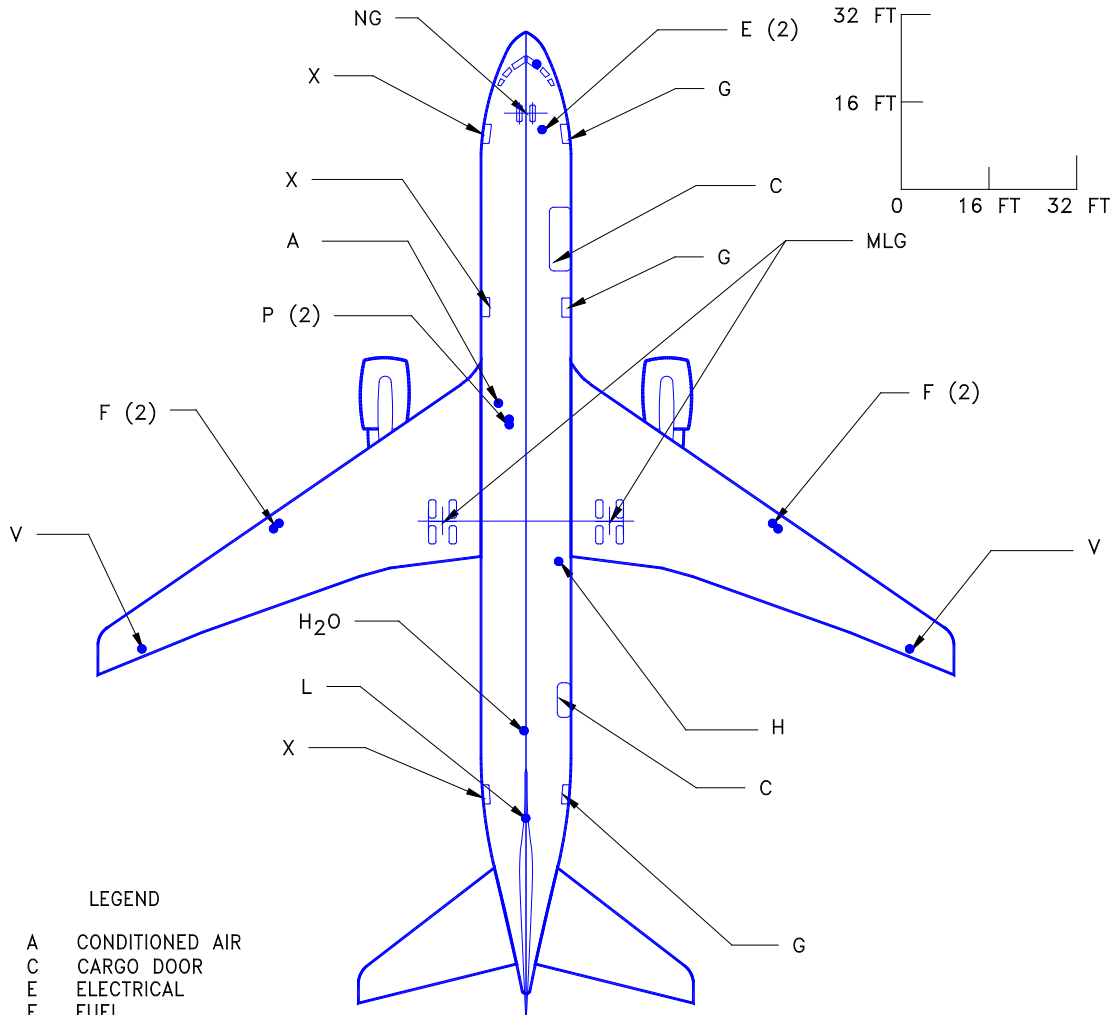

LEGEND

- A CONDITIONED AIR
- C CARGO DOOR
- E ELECTRICAL
- F FUEL
- G GALLEY SERVICE DOOR
- H HYDRAULIC
- H₂O POTABLE WATER
- L LAVATORY
- MLG MAIN LANDING GEAR
- NG NOSE GEAR
- P PNEUMATIC
- V FUEL VENT
- X PASSENGER DOOR

NOTE: FOR TURNING RADIUS DATA
SEE SECTIONS 4.2 AND 4.3

NOTE: ADJUST FOR PROPER SCALING WHEN PRINTING THIS PAGE

9.2.2 Scaled Drawings – 1 IN. = 32 FT: Model 767-300, -300ER

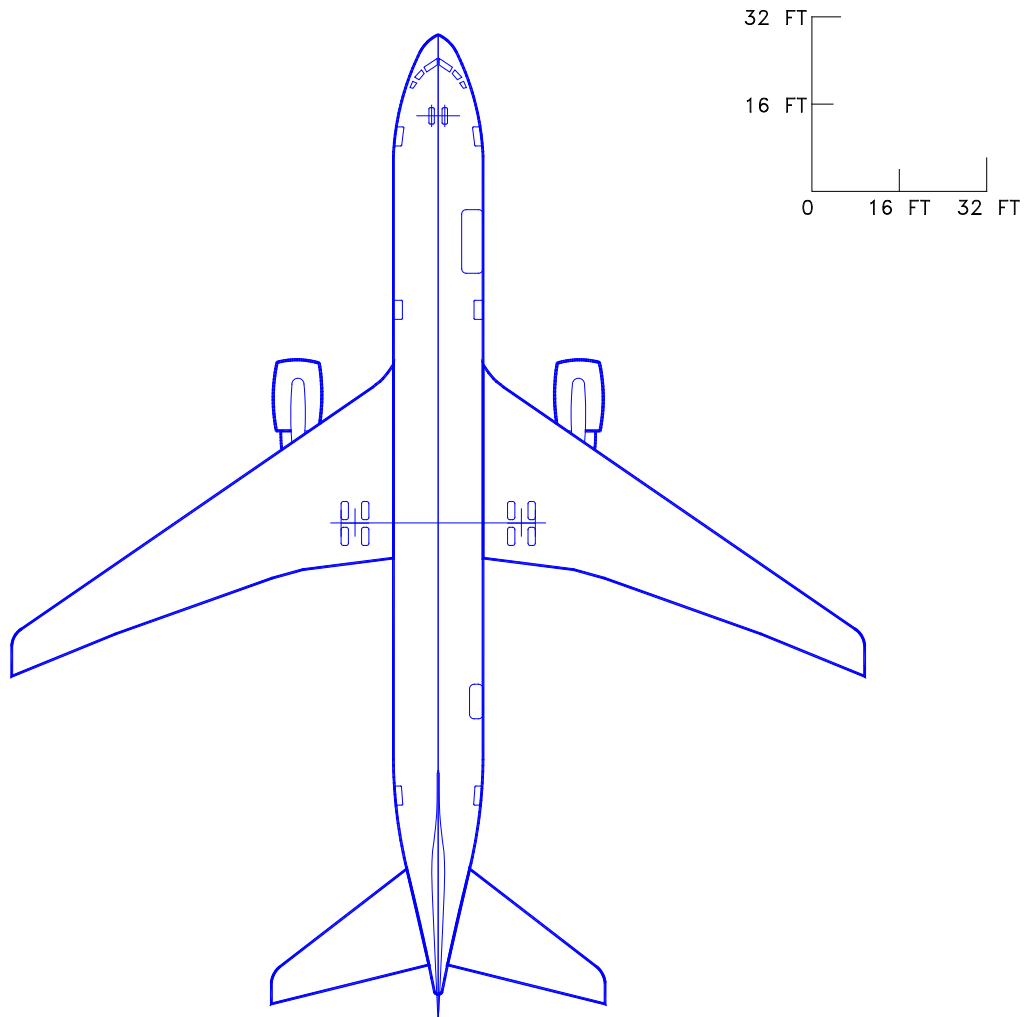

NOTE: ADJUST FOR PROPER SCALING WHEN PRINTING THIS PAGE

9.2.3 Scaled Drawings – 1 IN. = 50 FT: Model 767-300, -300ER

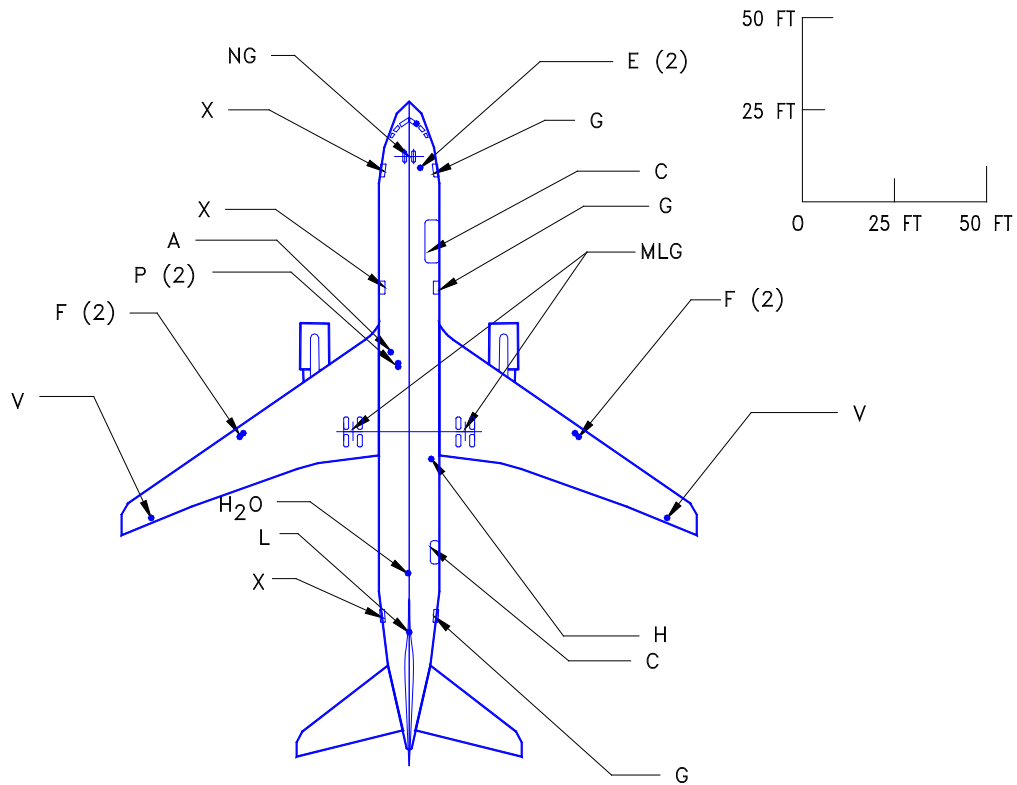

LEGEND

- A CONDITIONED AIR
- C CARGO DOOR
- E ELECTRICAL
- F FUEL
- G GALLEY SERVICE DOOR
- H HYDRAULIC
- H₂O POTABLE WATER
- L LAVATORY
- MLG MAIN LANDING GEAR
- NG NOSE GEAR
- P PNEUMATIC
- V FUEL VENT
- X PASSENGER DOOR

NOTE: FOR TURNING RADIUS DATA
SEE SECTIONS 4.2 AND 4.3

NOTE: ADJUST FOR PROPER SCALING WHEN PRINTING THIS PAGE

D6-58328

REV I

July 2021

9-14

9.2.4 Scaled Drawings – 1 IN. = 50 FT: Model 767-300, -300ER

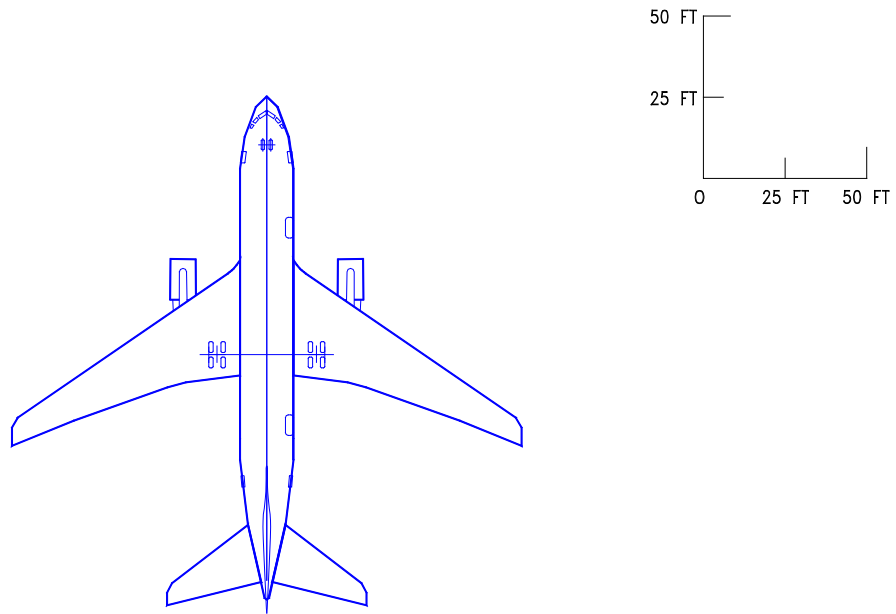

NOTE: ADJUST FOR PROPER SCALING WHEN PRINTING THIS PAGE

9.2.5 Scaled Drawings – 1 IN. = 100 FT: Model 767-300, -300ER

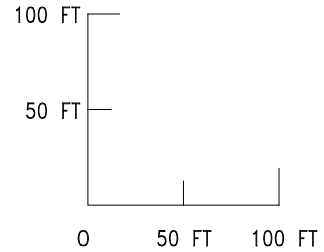
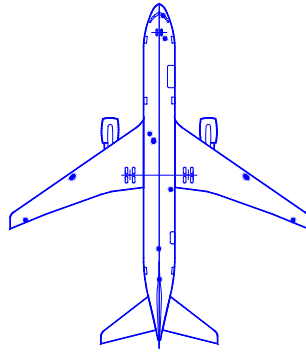

NOTE:

SEE SEC 9.6.1
LOCATIONS AND IDENTIFICATIONS
OF SERVICE POINTS

LEGEND

- A CONDITIONED AIR
- C CARGO DOOR
- E ELECTRICAL
- F FUEL
- G GALLEY SERVICE DOOR
- H HYDRAULIC
- H₂O POTABLE WATER
- L LAVATORY
- MLG MAIN LANDING GEAR
- NG NOSE GEAR
- P PNEUMATIC
- V FUEL VENT
- X PASSENGER DOOR

NOTE: FOR TURNING RADIUS DATA
SEE SECTIONS 4.2 AND 4.3

NOTE: ADJUST FOR PROPER SCALING WHEN PRINTING THIS PAGE

9.2.6 Scaled Drawings – 1 IN. = 100 FT: Model 767-300, -300ER

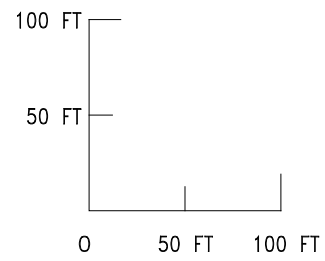
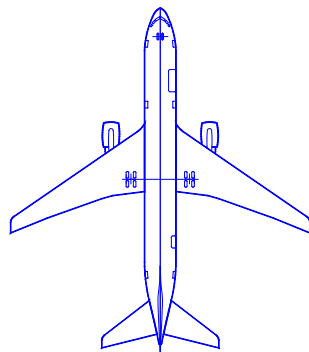

NOTE: ADJUST FOR PROPER SCALING WHEN PRINTING THIS PAGE

9.2.7 Scaled Drawings – 1:500: Model 767-300, -300ER

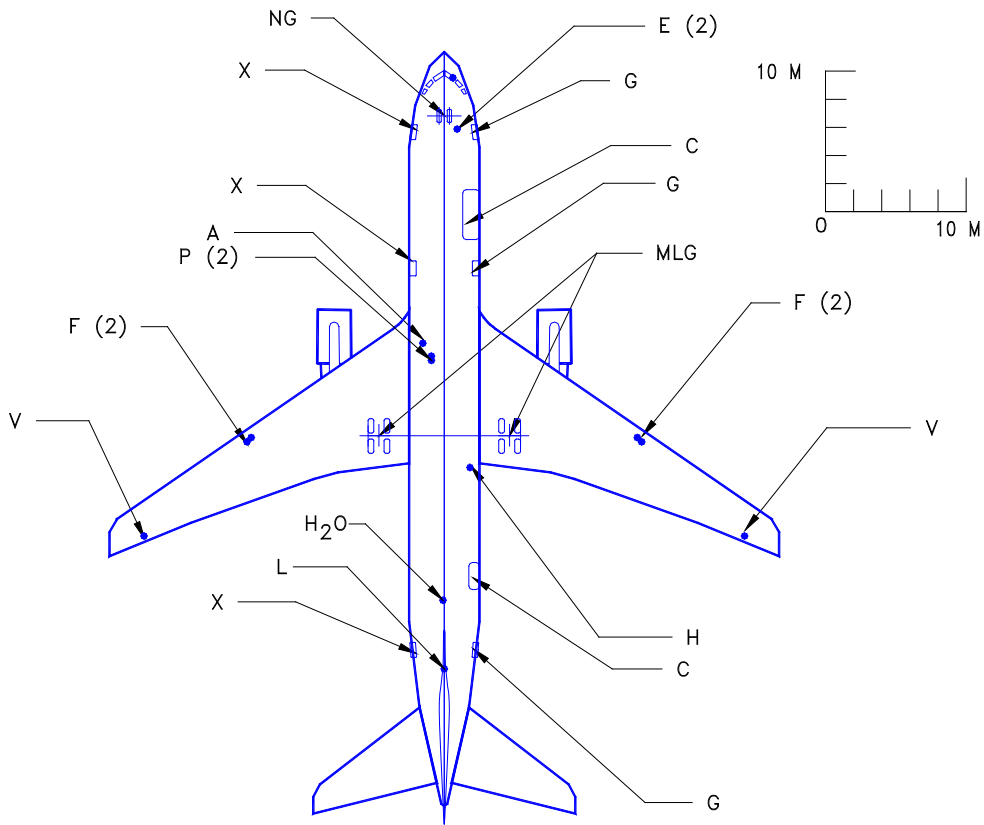

LEGEND

A	CONDITIONED AIR
C	CARGO DOOR
E	ELECTRICAL
F	FUEL
G	GALLEY SERVICE DOOR
H	HYDRAULIC
H ₂ O	POTABLE WATER
L	LAVATORY
MLG	MAIN LANDING GEAR
NG	NOSE GEAR
P	PNEUMATIC
V	FUEL VENT
X	PASSENGER DOOR

NOTE: FOR TURNING RADIUS DATA
SEE SECTIONS 4.2 AND 4.3

NOTE: ADJUST FOR PROPER SCALING WHEN PRINTING THIS PAGE

D6-58328

REV I

July 2021

9-18

9.2.8 Scaled Drawings – 1:500: Model 767-300, -300ER

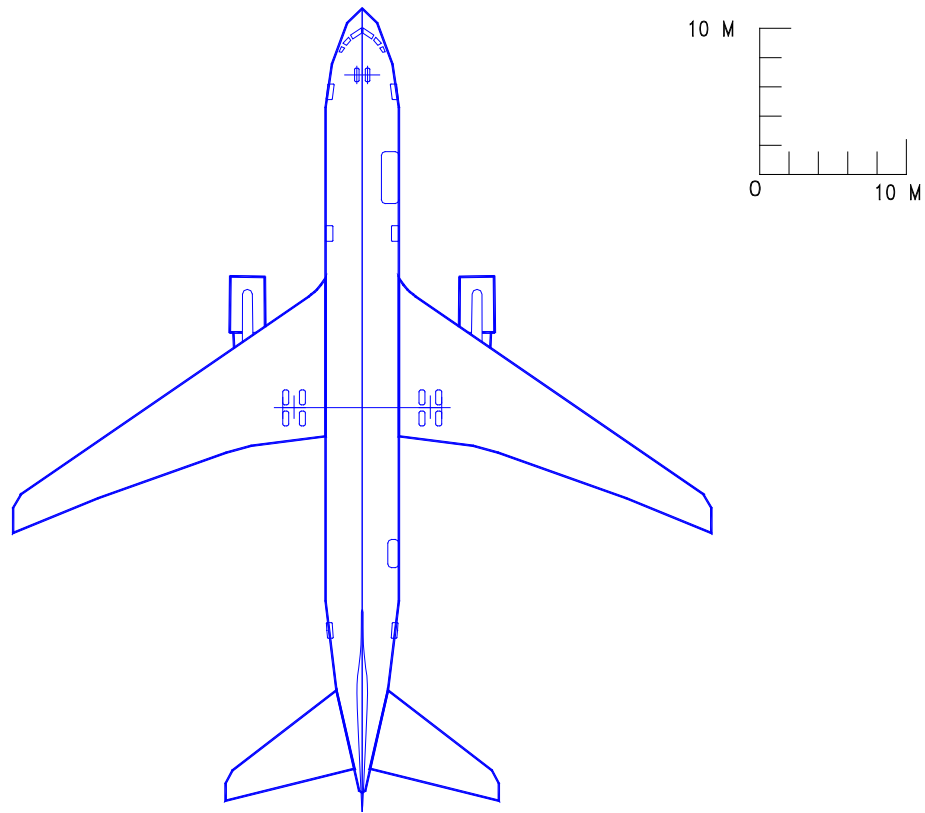

NOTE: ADJUST FOR PROPER SCALING WHEN PRINTING THIS PAGE

9.2.9 Scaled Drawings – 1:1000: Model 767-300, -300ER

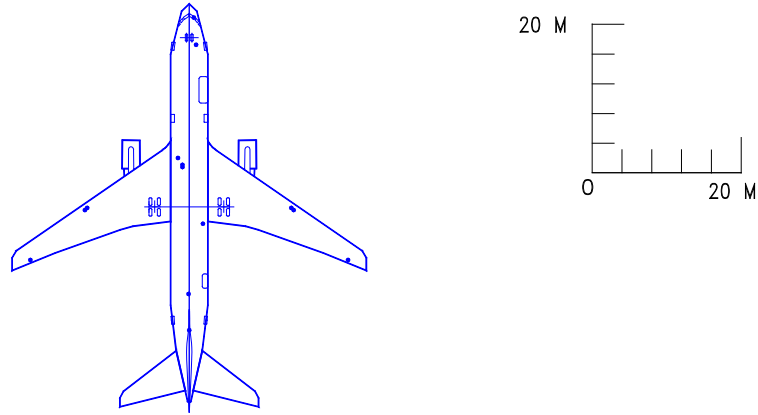

NOTE:

SEE SEC 9.6.1
LOCATIONS AND IDENTIFICATIONS
OF SERVICE POINTS

LEGEND

A CONDITIONED AIR
C CARGO DOOR
E ELECTRICAL
F FUEL
G GALLEY SERVICE DOOR
H HYDRAULIC
H₂O POTABLE WATER
L LAVATORY
MLG MAIN LANDING GEAR
NG NOSE GEAR
P PNEUMATIC
V FUEL VENT
X PASSENGER DOOR

NOTE: FOR TURNING RADIUS DATA
 SEE SECTIONS 4.2 AND 4.3

NOTE: ADJUST FOR PROPER SCALING WHEN PRINTING THIS PAGE

9.2.10 Scaled Drawings – 1:1000: Model 767-300, -300ER

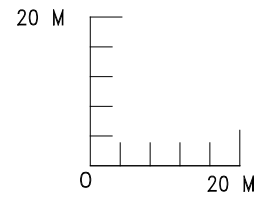
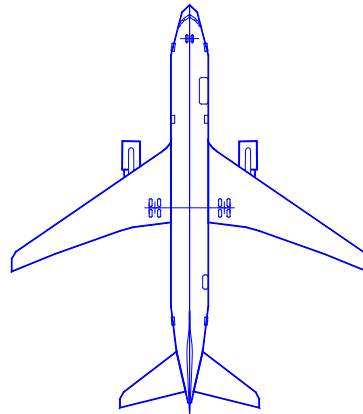

NOTE: ADJUST FOR PROPER SCALING WHEN PRINTING THIS PAGE

9.3 MODEL 767-300 FREIGHTER

9.3.1 Scaled Drawings – 1 IN. = 32 FT: Model 767-300 Freighter

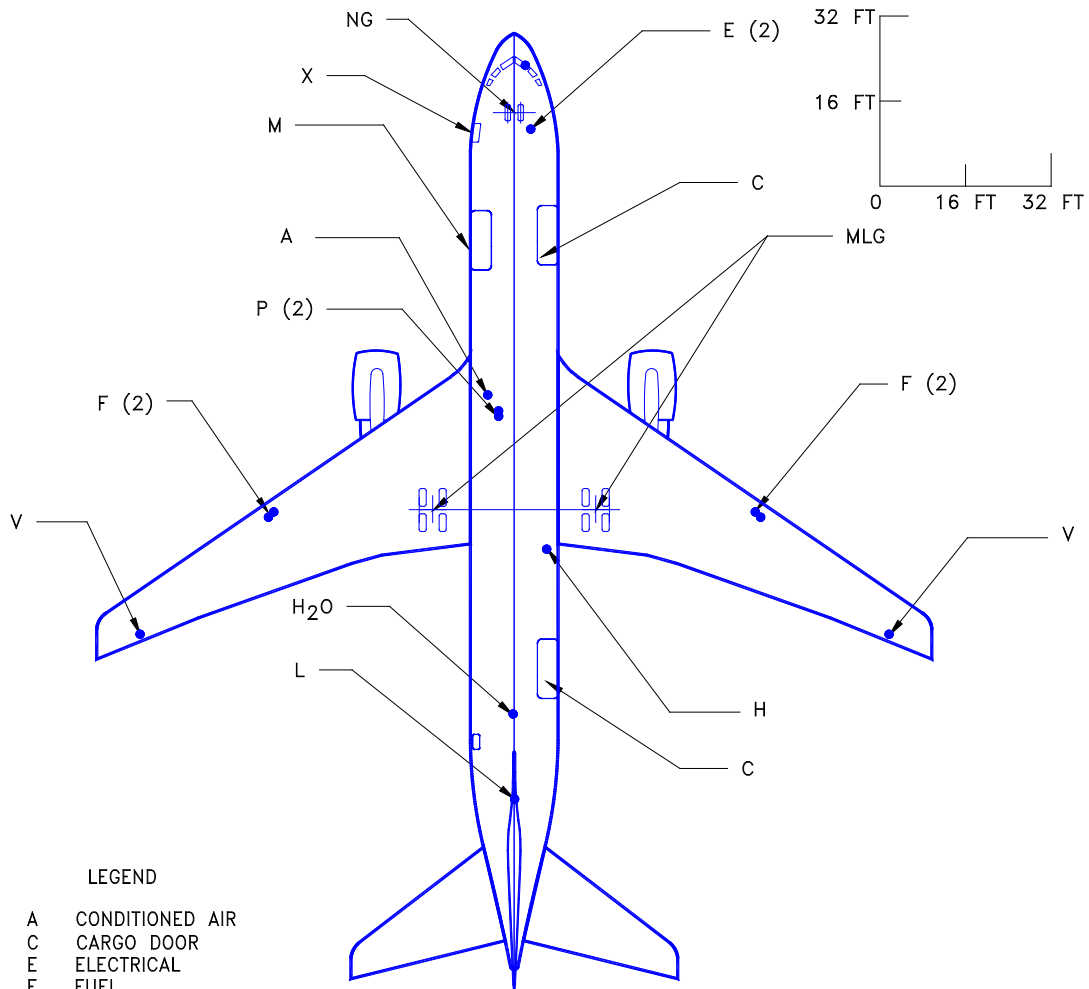

LEGEND

A	CONDITIONED AIR
C	CARGO DOOR
E	ELECTRICAL
F	FUEL
H	HYDRAULIC
H ₂ O	POTABLE WATER
L	LAVATORY
M	MAIN DECK CARGO DOOR
MLG	MAIN LANDING GEAR
NG	NOSE GEAR
P	PNEUMATIC
V	FUEL VENT
X	CREW ENTRY DOOR

NOTE: FOR TURNING RADIUS DATA
SEE SECTIONS 4.2 AND 4.3

NOTE: ADJUST FOR PROPER SCALING WHEN PRINTING THIS PAGE

9.3.2 Scaled Drawings – 1 IN. = 32 FT: Model 767-300 Freighter

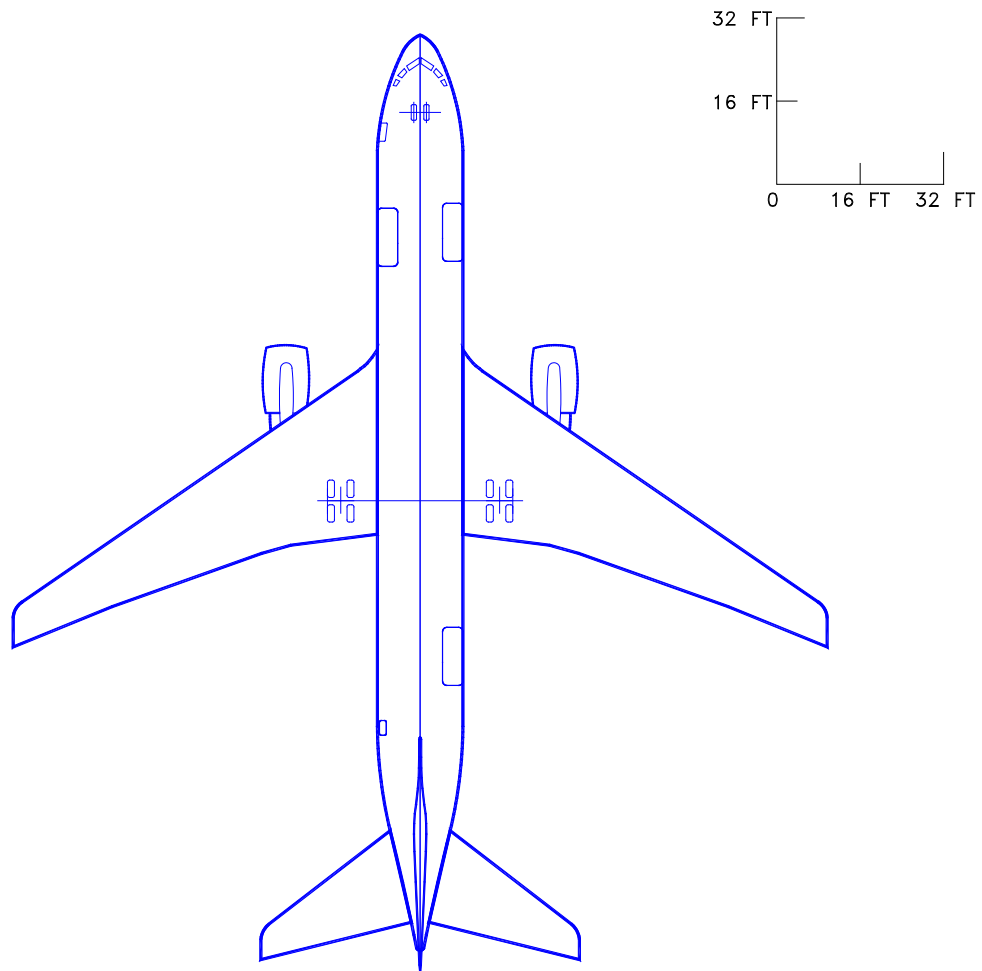

NOTE: ADJUST FOR PROPER SCALING WHEN PRINTING THIS PAGE

9.3.3 Scaled Drawings – 1 IN. = 50 FT: Model 767-300 Freighter

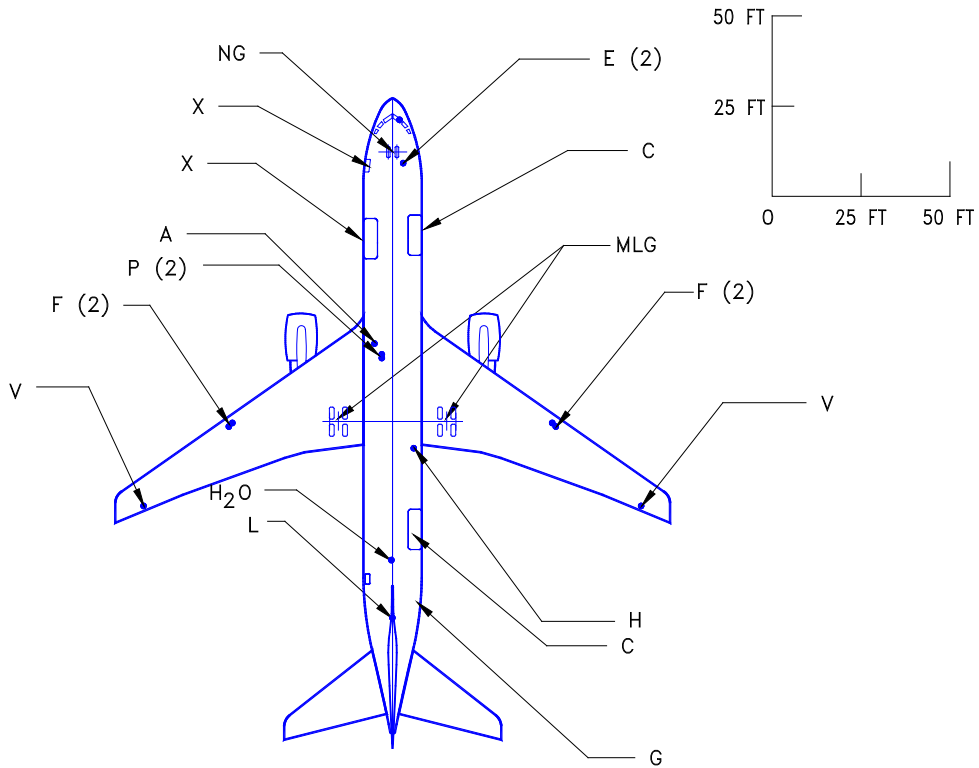

LEGEND

- A CONDITIONED AIR
- C CARGO DOOR
- E ELECTRICAL
- F FUEL
- H HYDRAULIC
- H₂O POTABLE WATER
- L LAVATORY
- M MAIN DECK CARGO DOOR
- MLG MAIN LANDING GEAR
- NG NOSE GEAR
- P PNEUMATIC
- V FUEL VENT
- X CREW ENTRY DOOR

NOTE: FOR TURNING RADIUS DATA
SEE SECTIONS 4.2 AND 4.3

NOTE: ADJUST FOR PROPER SCALING WHEN PRINTING THIS PAGE

9.3.4 Scaled Drawings – 1 IN. = 50 FT: Model 767-300 Freighter

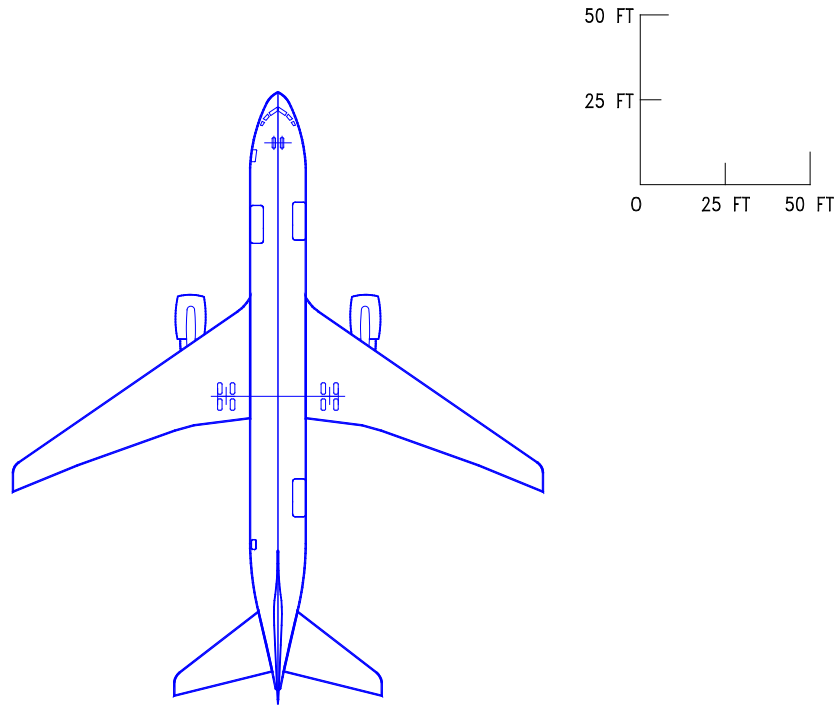

NOTE: ADJUST FOR PROPER SCALING WHEN PRINTING THIS PAGE

9.3.5 Scaled Drawings – 1 IN. = 100 FT: Model 767-300 Freighter

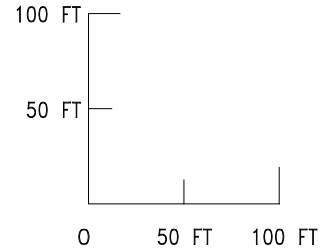
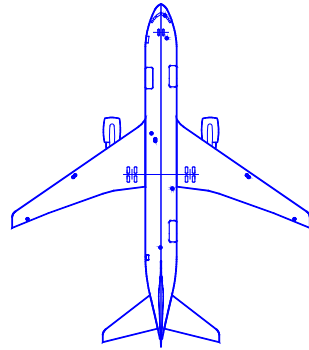

NOTE:

SEE SEC 9.11.1
LOCATIONS AND IDENTIFICATIONS
OF SERVICE POINTS

LEGEND

A CONDITIONED AIR
C CARGO DOOR
E ELECTRICAL
F FUEL
H HYDRAULIC
H₂O POTABLE WATER
L LAVATORY
M MAIN DECK CARGO DOOR
MLG MAIN LANDING GEAR
NG NOSE GEAR
P PNEUMATIC
V FUEL VENT
X CREW ENTRY DOOR

NOTE: FOR TURNING RADIUS DATA
SEE SECTIONS 4.2 AND 4.3

NOTE: ADJUST FOR PROPER SCALING WHEN PRINTING THIS PAGE

D6-58328

REV I

July 2021

9-26

9.3.6 Scaled Drawings – 1 IN. = 100 FT: Model 767-300 Freighter

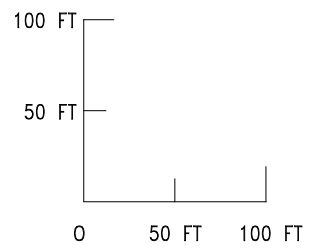
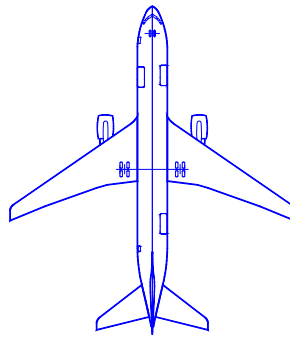

NOTE: ADJUST FOR PROPER SCALING WHEN PRINTING THIS PAGE

9.3.7 Scaled Drawings – 1:500: Model 767-300 Freighter

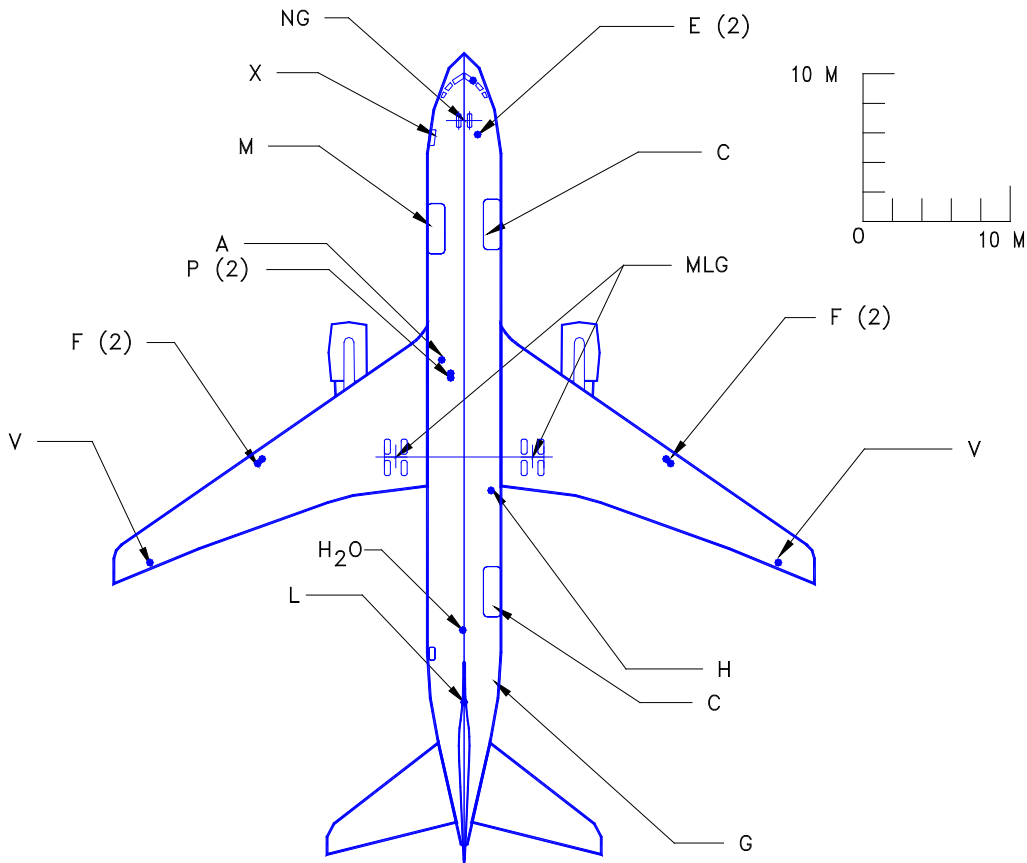

LEGEND

- A CONDITIONED AIR
- C CARGO DOOR
- E ELECTRICAL
- F FUEL
- H HYDRAULIC
- H₂O POTABLE WATER
- L LAVATORY
- M MAIN DECK CARGO DOOR
- MLG MAIN LANDING GEAR
- NG NOSE GEAR
- P PNEUMATIC
- V FUEL VENT
- X CREW ENTRY DOOR

NOTE: FOR TURNING RADIUS DATA
SEE SECTIONS 4.2 AND 4.3

NOTE: ADJUST FOR PROPER SCALING WHEN PRINTING THIS PAGE

D6-58328

REV I

July 2021

9-28

9.3.8 Scaled Drawings – 1:500: Model 767-300 Freighter

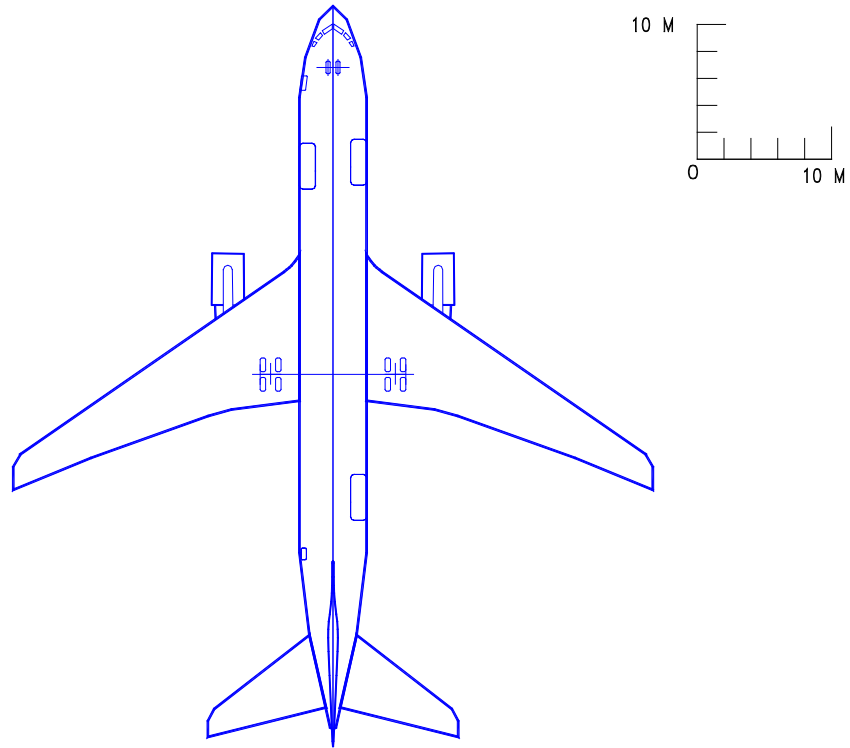

NOTE: ADJUST FOR PROPER SCALING WHEN PRINTING THIS PAGE

9.3.9 Scaled Drawings – 1:1000: Model 767-300 Freighter

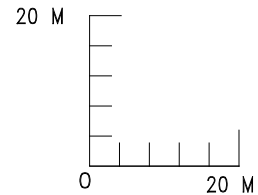
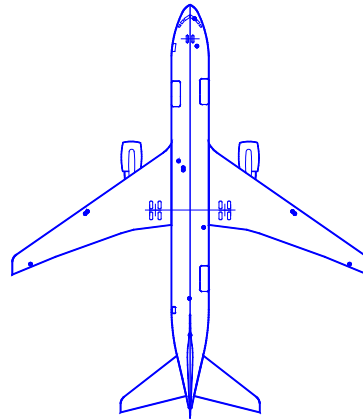

NOTE:

SEE SEC 9.11.1
LOCATIONS AND IDENTIFICATIONS
OF SERVICE POINTS

LEGEND

A CONDITIONED AIR
C CARGO DOOR
E ELECTRICAL
F FUEL
H HYDRAULIC
H₂O POTABLE WATER
L LAVATORY
M MAIN DECK CARGO DOOR
MLG MAIN LANDING GEAR
NG NOSE GEAR
P PNEUMATIC
V FUEL VENT
X CREW ENTRY DOOR

NOTE: FOR TURNING RADIUS DATA
SEE SECTIONS 4.2 AND 4.3

NOTE: ADJUST FOR PROPER SCALING WHEN PRINTING THIS PAGE

D6-58328

REV I

July 2021

9-30

9.3.10 Scaled Drawings – 1:1000: Model 767-300 Freighter

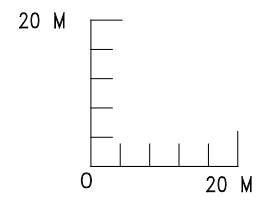
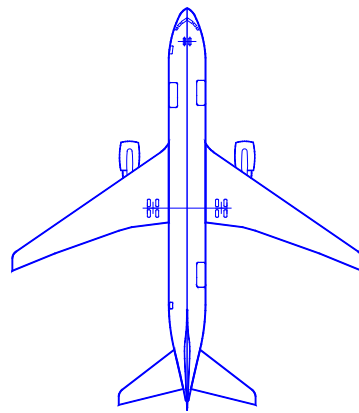

NOTE: ADJUST FOR PROPER SCALING WHEN PRINTING THIS PAGE

9.4 MODEL 767-400ER

9.4.1 Scaled Drawings – 1 IN. = 32 FT: Model 767-400ER

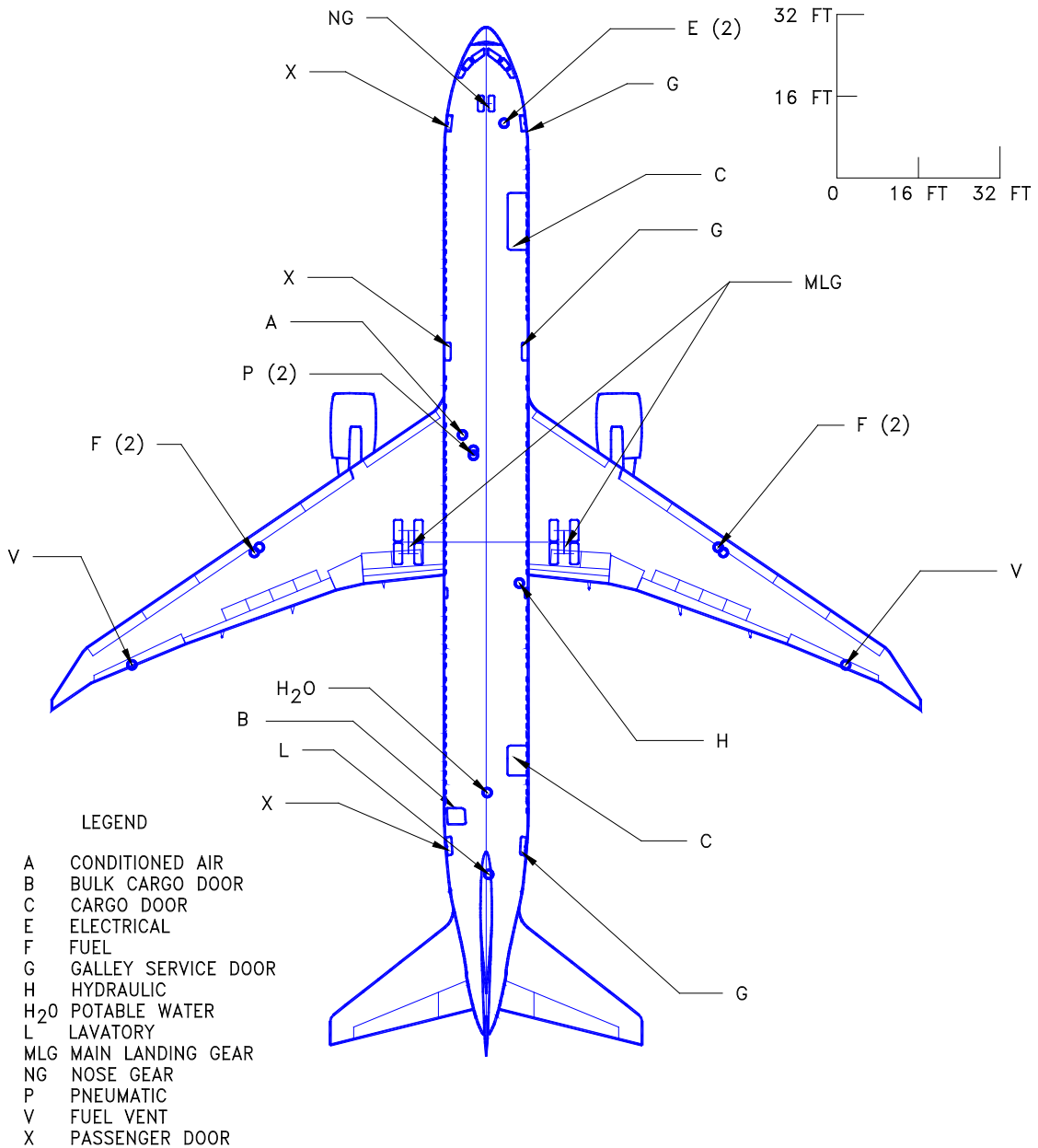

NOTE: FOR TURNING RADIUS DATA
SEE SECTIONS 4.2 AND 4.3

NOTE: ADJUST FOR PROPER SCALING WHEN PRINTING THIS PAGE

D6-58328

REV I

July 2021

9-32

9.4.2 Scaled Drawings – 1 IN. = 32 FT: Model 767-400ER

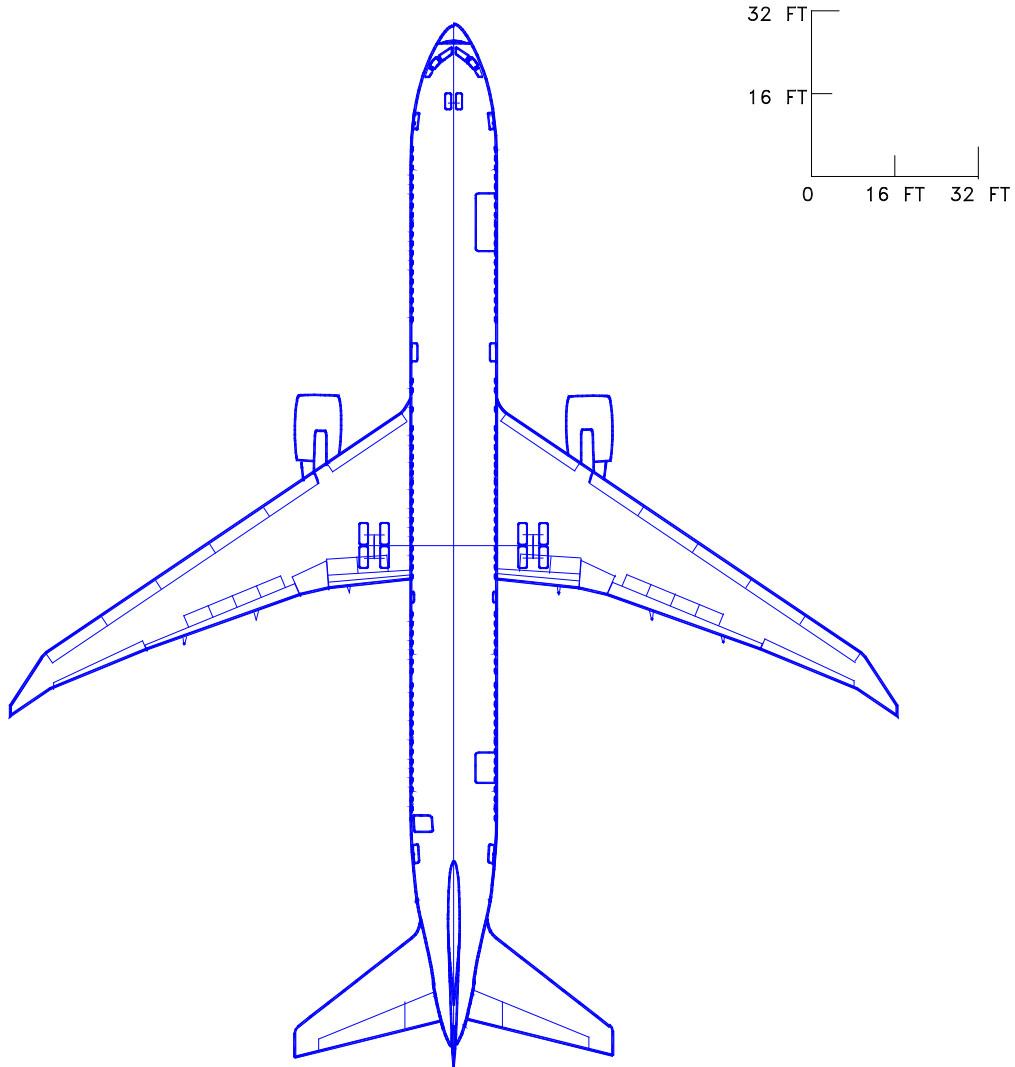

NOTE: ADJUST FOR PROPER SCALING WHEN PRINTING THIS PAGE

9.4.3 Scaled Drawings – 1 IN. = 50 FT: Model 767-400ER

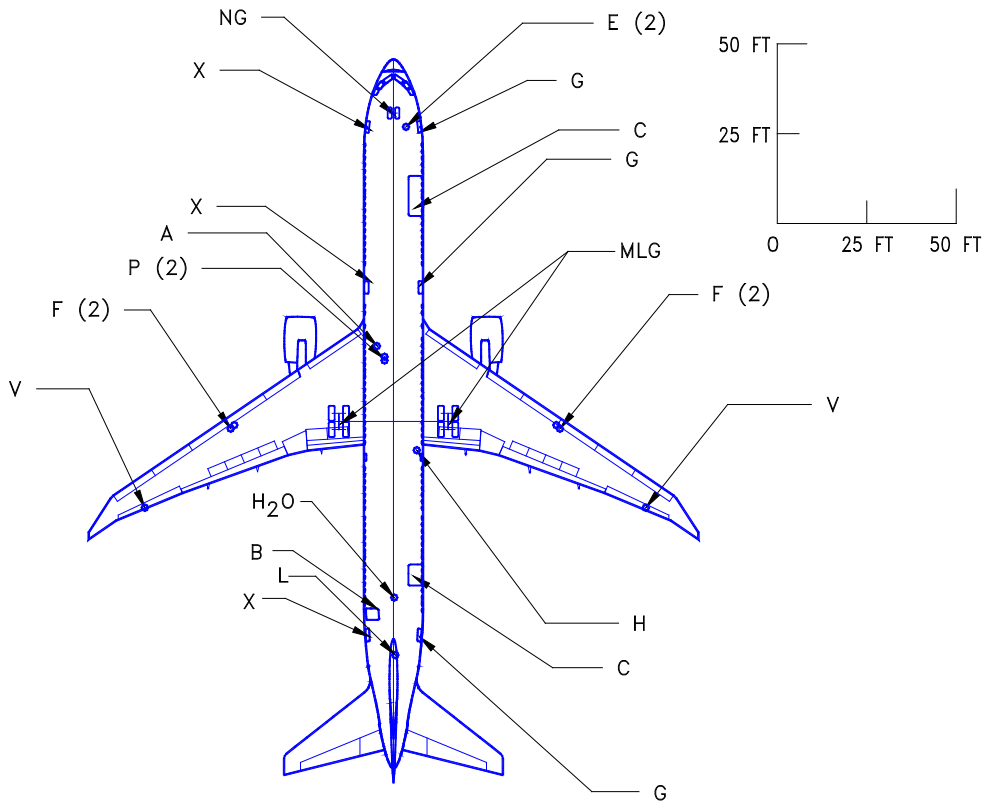

LEGEND

- A CONDITIONED AIR
- B BULK CARGO DOOR
- C CARGO DOOR
- E ELECTRICAL
- F FUEL
- G GALLEY SERVICE DOOR
- H HYDRAULIC
- H₂O POTABLE WATER
- L LAVATORY
- MLG MAIN LANDING GEAR
- NG NOSE GEAR
- P PNEUMATIC
- V FUEL VENT
- X PASSENGER DOOR

NOTE: FOR TURNING RADIUS DATA
SEE SECTIONS 4.2 AND 4.3

NOTE: ADJUST FOR PROPER SCALING WHEN PRINTING THIS PAGE

9.4.4 Scaled Drawings – 1 IN. = 50 FT: Model 767-400ER

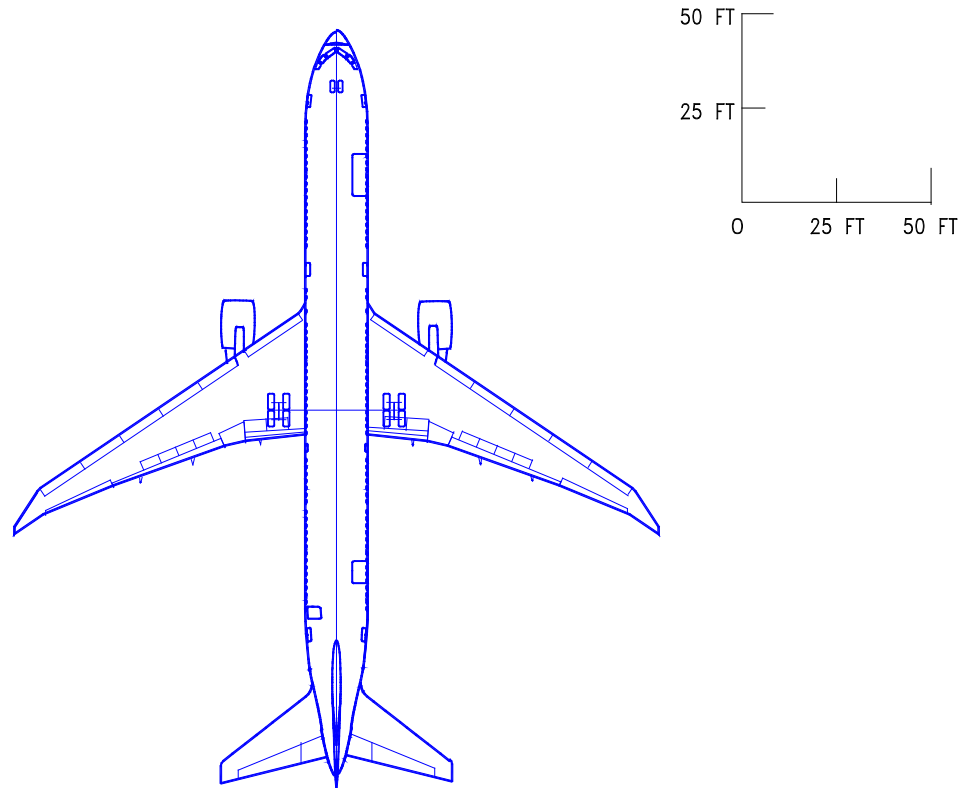

NOTE: ADJUST FOR PROPER SCALING WHEN PRINTING THIS PAGE

9.4.5 Scaled Drawings – 1 IN. = 100 FT: Model 767-400ER

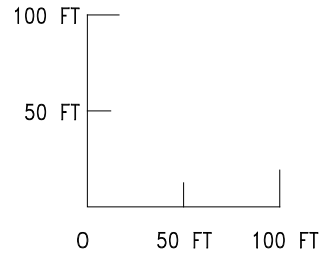
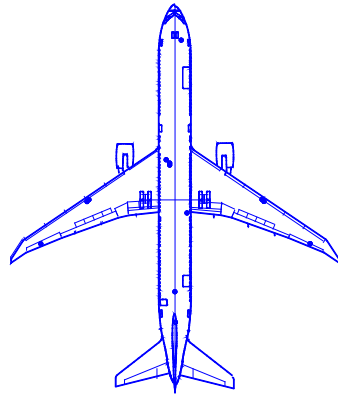

NOTE:

SEE SEC 9.16.1
LOCATIONS AND IDENTIFICATIONS
OF SERVICE POINTS

LEGEND

A CONDITIONED AIR
B BULK CARGO DOOR
C CARGO DOOR
E ELECTRICAL
F FUEL
G GALLEY SERVICE DOOR
H HYDRAULIC
H₂O POTABLE WATER
L LAVATORY
MLG MAIN LANDING GEAR
NG NOSE GEAR
P PNEUMATIC
V FUEL VENT
X PASSENGER DOOR

NOTE: FOR TURNING RADIUS DATA
SEE SECTIONS 4.2 AND 4.3

NOTE: ADJUST FOR PROPER SCALING WHEN PRINTING THIS PAGE

9.4.6 Scaled Drawings – 1 IN. = 100 FT: Model 767-400ER

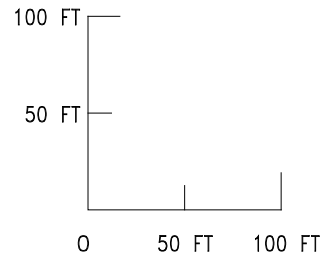
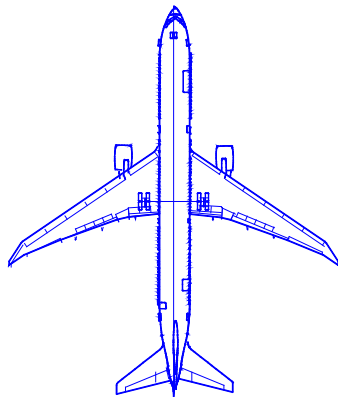

NOTE: ADJUST FOR PROPER SCALING WHEN PRINTING THIS PAGE

9.4.7 Scaled Drawings – 1:500: Model 767-400ER

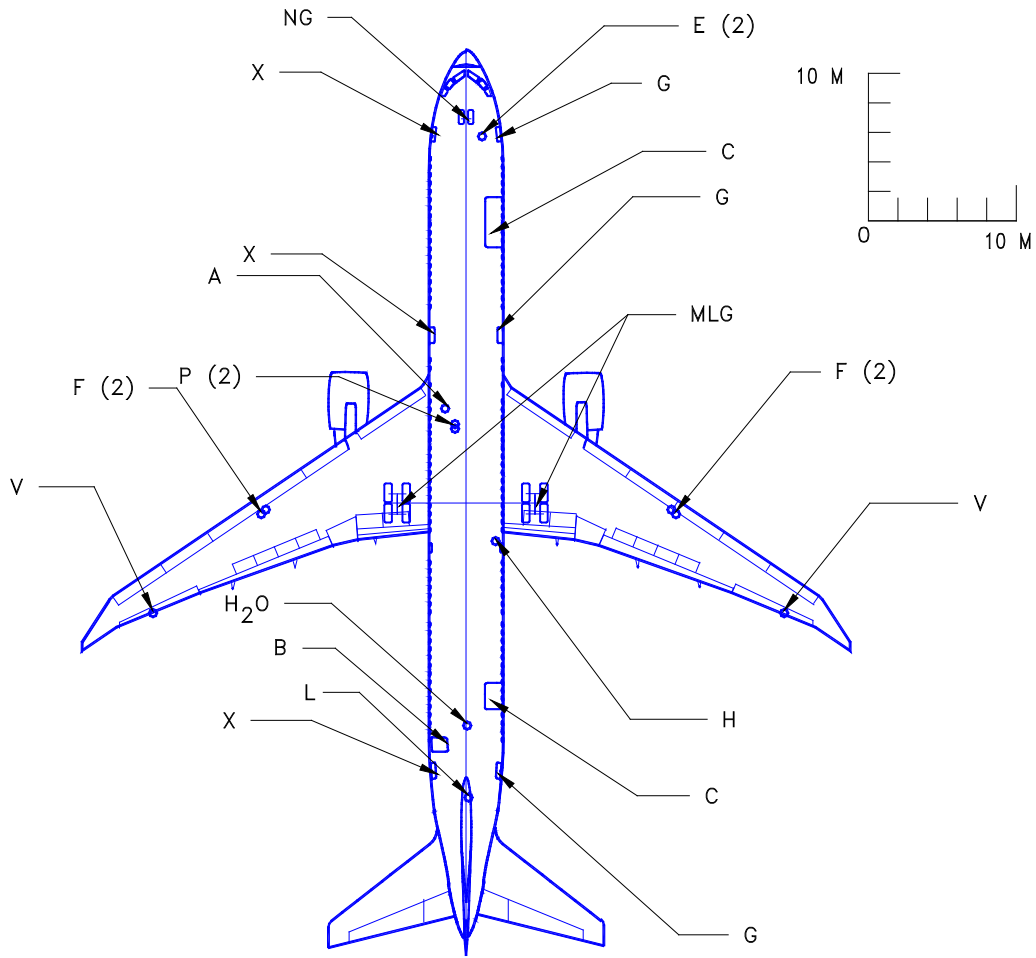

LEGEND

- A CONDITIONED AIR
- B BULK CARGO DOOR
- C CARGO DOOR
- E ELECTRICAL
- F FUEL
- G GALLEY SERVICE DOOR
- H HYDRAULIC
- H₂O POTABLE WATER
- L LAVATORY
- MLG MAIN LANDING GEAR
- NG NOSE GEAR
- P PNEUMATIC
- V FUEL VENT
- X PASSENGER DOOR

NOTE: FOR TURNING RADIUS DATA
SEE SECTIONS 4.2 AND 4.3

NOTE: ADJUST FOR PROPER SCALING WHEN PRINTING THIS PAGE

9.4.8 Scaled Drawings – 1:500: Model 767-400ER

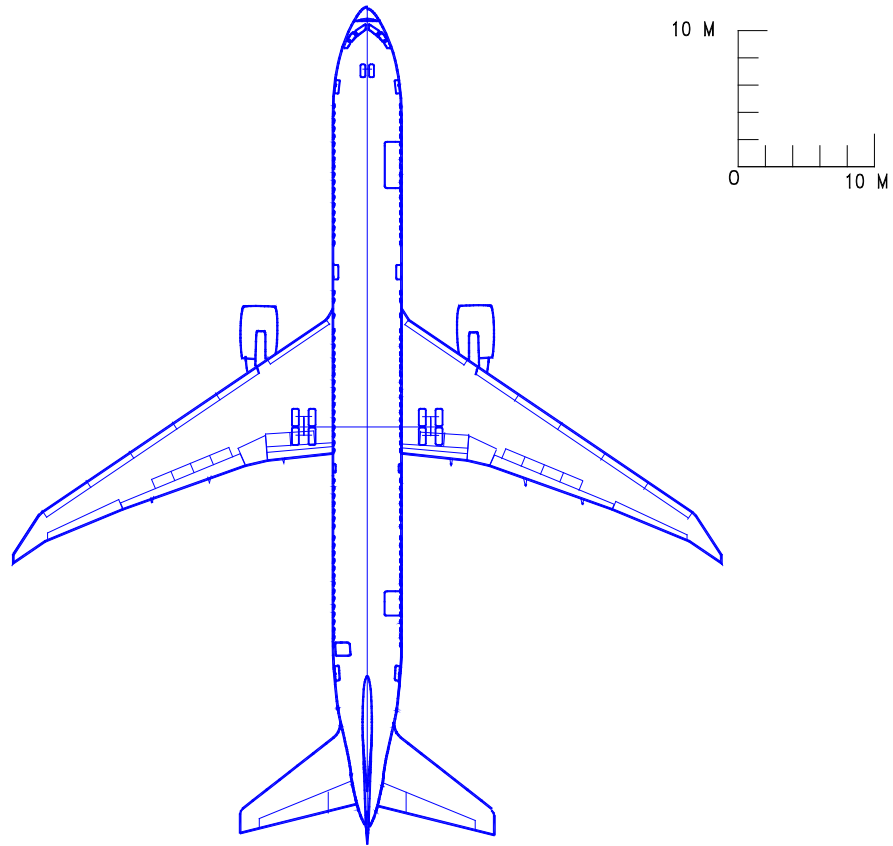

NOTE: ADJUST FOR PROPER SCALING WHEN PRINTING THIS PAGE

9.4.9 Scaled Drawings – 1:1000: Model 767-400ER

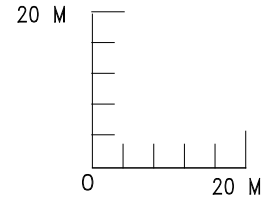
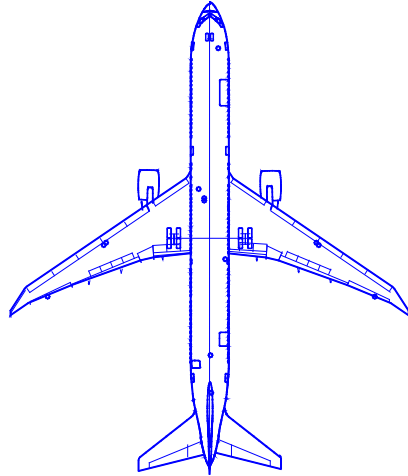

NOTE:

SEE SEC 9.16.1
LOCATIONS AND IDENTIFICATIONS
OF SERVICE POINTS

LEGEND

A	CONDITIONED AIR
B	BULK CARGO DOOR
C	CARGO DOOR
E	ELECTRICAL
F	FUEL
G	GALLEY SERVICE DOOR
H	HYDRAULIC
H ₂ O	POTABLE WATER
L	LAVATORY
MLG	MAIN LANDING GEAR
NG	NOSE GEAR
P	PNEUMATIC
V	FUEL VENT
X	PASSENGER DOOR

NOTE: FOR TURNING RADIUS DATA
SEE SECTIONS 4.2 AND 4.3

NOTE: ADJUST FOR PROPER SCALING WHEN PRINTING THIS PAGE

9.4.10 Scaled Drawings – 1:1000: Model 767-400ER

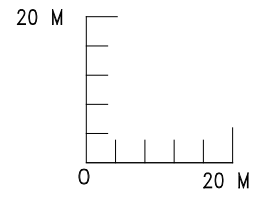
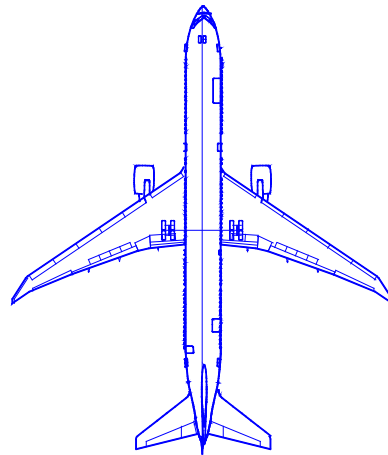

NOTE: ADJUST FOR PROPER SCALING WHEN PRINTING THIS PAGE