

Status report 109 - High Performance Light Water Reactor (HP-LWR)

Overview

Full name	High Performance Light Water Reactor
Acronym	HP-LWR
Reactor type	Pressurized Water Reactor (PWR)
Coolant	Light Water
Moderator	Light water
Neutron spectrum	Thermal Neutrons
Thermal capacity	2300.00 MWth
Gross Electrical capacity	1046.00 MWe
Design status	Concept Description
Designers	Karlsruhe Institute of Technology
Last update	29-08-2011

Description

Introduction

Following the trend of coal fired power plants in the last 20 years, the evolutionary development to higher temperatures and pressures, which are meanwhile exceeding even the critical pressure of water, has been considered by the Generation IV International Forum (GIF) as an option also for future water cooled reactors. The higher steam enthalpy could enable a direct, once through steam cycle such that neither steam generators nor steam separators and dryers would be required, and even primary coolant pumps could be omitted. Thus the coolant mass flow through the core is only driven by the feedwater pumps. Moreover, steam turbines and re-heaters could be significantly smaller than today, while the steam cycle efficiency would even be higher. As fossil fired power plants with supercritical steam conditions have been operated during the last 20 years, reaching 600°C live steam temperature or even more, this nuclear plant concept can benefit from proven design of turbines, feedwater pumps and most other components of the steam cycle except the re-heater. Moreover, the containment design can basically be derived from the latest boiling water reactors.

In Europe, a consortium of 12 organizations from 8 European countries (see Chapter 12) started in 2006 to address this challenge by working out a design concept of such a reactor, which they called the High Performance Light Water Reactor (HPLWR), with a core exit temperature of at least 500°C at a supercritical system pressure of around 25 MPa. The design objectives were a core with a thermal neutron spectrum, a net electric power of 1000 MW and a net plant efficiency of around 44%. The project plan has been outlined by Starfinger et al. [1]. Meanwhile, the project has been completed in 2010 and the final report has been published in the 6th Framework Programme of the European Commission [2].

On a closer look, the core of the HPLWR has to solve a lot more design challenges than simply an increase of the core exit temperature by around 200°C. Assuming a typical feedwater temperature of supercritical fossil fired power plants of 280°C, the enthalpy rise in the core would exceed the one of conventional light water reactors by almost a factor of ten. A conventional LWR core design with a single stage coolant heat up from bottom to top would result in peak cladding temperatures beyond any reasonable cladding material limits, if all power and mass flow non-uniformities, uncertainties and tolerances as well as allowances for operation are taken into account. Ideas to solve this issue can be found at coal fired boilers. There, the coolant is typically heated up in three steps, namely the evaporator (which means the transition from liquid like to steam like conditions at supercritical pressure) and a first and second superheater with higher temperature but lower power when approaching the envisaged boiler outlet temperature. Intensive coolant mixing between each step eliminates hot streaks of the preceding step before entering the next one. As an example, Schulenberg et al. [3] proposed a thermal core concept in which the evaporator assemblies are placed in the centre of the core, followed by first superheater assemblies with downward flow surrounding them, and second superheater assemblies with upward flow at the core periphery where the fissile power is low anyway because of neutron leakage. The European consortium decided in Sept. 2006 to take this example as a basis for their joint core design study.

The safety system of the HPLWR is very similar to existing boiling water reactors. In principle, active (e.g. low pressure coolant injection system) and passive components (e.g. containment condenser) have been used as part of the overall strategy dealing with accidents and transients. The analyses showed that the behaviour of the HPLWR reacts very benignly in case of reactivity induced accidents. For transients, the investigated cases never lead to an unfavourable behaviour of the reactor core. In case of accidents, like loss of coolant accidents, the reactor behaves like a conventional boiling water reactor, which means that an emergency core cooling system must be foreseen in the safety concept. However, a significant difference in the safety approach compared to existing light water reactors must be noted: Due to the missing recirculation inside the reactor pressure vessel, the coolant flow must always be maintained. Simply maintaining the water inventory in the vessel does not lead to successful core cooling. Therefore, automatic depressurization of the pressure vessel has been foreseen as a passive, fast responding system to remove heat in the short term in case of several accident scenarios.

Besides the core design and analysis, the HPLWR project included the design concepts of the reactor pressure vessel, the containment with its safety systems, as well as major components of the balance of plant including first analyses of them to assess realistically costs and safety features of the power plant. The project was accompanied by cladding material tests and detailed heat transfer studies which were identified as key technologies of supercritical water cooled reactors by the Generation IV International Forum.

The technical data (Appendix 1) summarize the key features of this innovative reactor concept. Aiming at a net electric power of around 1000MW and a net efficiency of almost 44%, the target thermal power of the reactor core needs to be 2300MW. Early cycle studies indicated an optimum thermal efficiency at a feedwater temperature of 280°C. The target core outlet temperature was chosen as 500°C which is still rather low for a once through steam cycle with single reheat, compared with latest fossil fired power plants, but appears to be challenging enough with regard to available fuel cladding materials. Their peak temperature limit was targeted at 630°C which is not only a challenge for oxidation and corrosion protection, but also for their creep strength and resistance to stress corrosion cracking. The fuel centreline temperature is a function of the linear power of the fuel rod. The latter one has been limited to 39kW/m under nominal conditions. To be competitive with respect to latest pressurized water reactors, the target burn up should be at least 60 MWd/t_{HM}. Like with boiling water reactors, boron acid cannot be used to compensate the excess reactivity at the beginning of a burn-up cycle, so that burnable absorbers like Gd must be used instead. The target power and temperatures result in a coolant mass flow rate of 1179kg/s. A constant feedwater pressure of 25MPa has been foreseen for all load conditions keeping some margin from the critical pressure of 22.1MPa.

Description of the nuclear systems

The reactor pressure vessel (RPV) is the main component of the primary system. The dimensioning of the RPV and its closure head as well as the design calculation for the studs, nuts and O-ring seals has been performed using the safety standards of the nuclear safety standards commission (KTA) in Germany. The RPV is designed to contain the core, mixing plenums, and control rods. Therefore, the minimum height of the vessel is defined by the height of the fuel assemblies plus the height of the extended control rods on top. In the radial direction, the diameter of the core and the thickness of the steel reflector and core barrel, together with the annulus of the downcomer, add up to the

smallest possible inner diameter of the vessel.

The reactor internals include the core barrel with its core support plate and the lower mixing plenum, the steel reflector, the steam plenum with adjustable outlet pipes and the control rod guide tubes. The core barrel is composed of a cylindrical part with flange and the lower core support plate with orifices as shown in Fig. 1. The purpose of the core barrel is the containment and fixation of the core with its 156 fuel assembly clusters, standing upright on the perforated lower core plate. The thick plate allows the clusters to maintain their orientation and position during operation. The upper part of the plate is formed like a shoulder and is welded to the bottom ledge of the core barrel. Struts of the RPV near the lower plate are used to align the core barrel horizontally.

The circular lower mixing plenum, which is welded to the bottom of the lower core plate, homogenizes the water flow from the downcomer before it enters through the plate into the lower part of the evaporator of the core. An annular mixing chamber underneath the core support plate, inside the lower mixing plenum, mixes the coolant from superheater 1 before it enters superheater 2.

The superheated steam is collected and mixed above all fuel assembly clusters in the steam plenum. This is a leak tight box, which is resting on support brackets of the RPV. An inner part, combining the evaporator outlet with superheater 1 inlet, is separated from an outer part at superheater 2 outlet. Four extractable steam pipes are positioned at the height of the steam plenum to guide the superheated steam through the outlet flanges of the RPV to the steam lines. The steam plenum can be moved in and out of the core barrel using guide rails in its upper part.

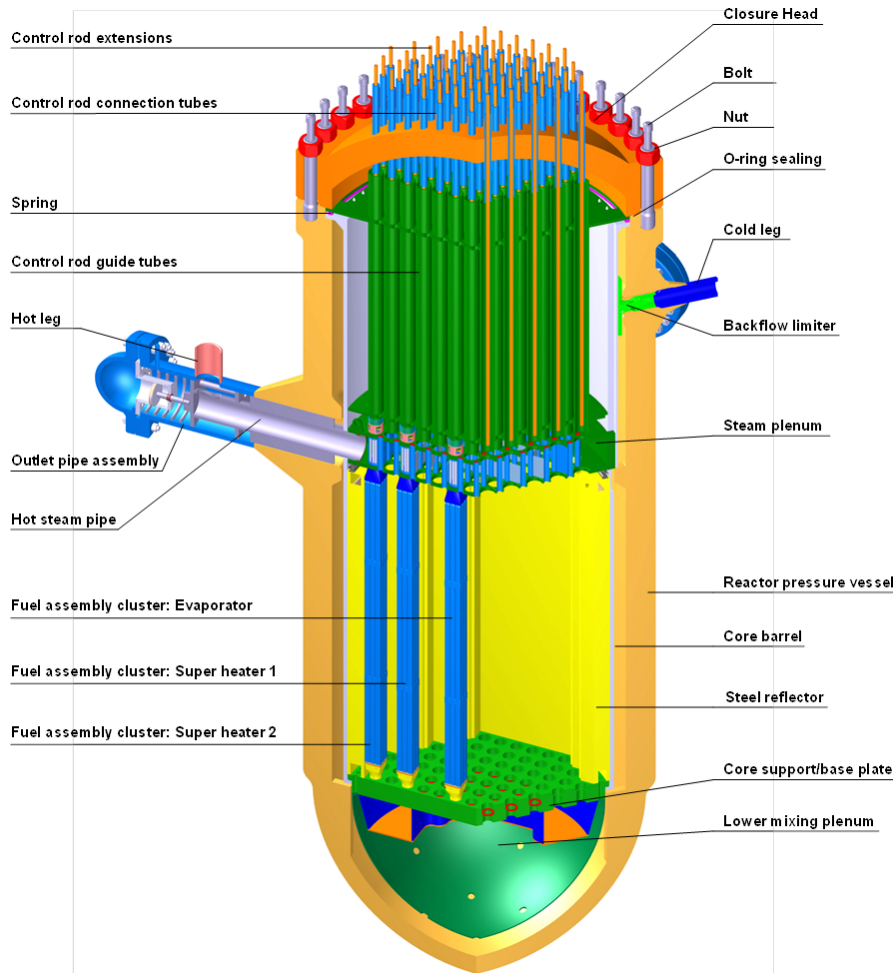

Fig. 1. Reactor pressure vessel and components of the nuclear system

To replace spent fuel assemblies, the steam plenum is lifted out of the core barrel using four mounts welded to its top plate. For that purpose, the four outlet pipes are pulled out radially, such that the nozzles of the outlet pipes do not obstruct the lift path any more, while the steam plenum still rests on the protruding support brackets.

The HPLWR core design concept assumes that 50% of the coolant supplied through 4 inlet flanges to the reactor

pressure vessel (RPV) is taken first as moderator water to run upwards to the closure head, then downwards through control rod guide tubes and through the central water boxes inside the housed assemblies, to be released through the foot pieces of the assembly clusters to the gap volume between the assembly boxes. From there, it rises upwards to serve again as moderator water outside the assembly boxes. It is collected at the top of the core to cool the radial core reflector with a downward flow, before it is mixed with the remaining 50% of the coolant in the lower mixing plenum underneath the core. The following three heat-up steps comprise an evaporator region formed by 52 assembly clusters in the core centre, where the coolant changes its density from liquid like to steam like conditions, followed by an upper mixing chamber above the core. Another 52 assembly clusters with downward flow surround the evaporator region and serve as the first superheater. After a second mixing in an annular mixing chamber underneath the core, the coolant is finally heated up to 500°C in a second superheater region formed by 52 assembly clusters at the core periphery. The core arrangement is shown in Fig. 2.

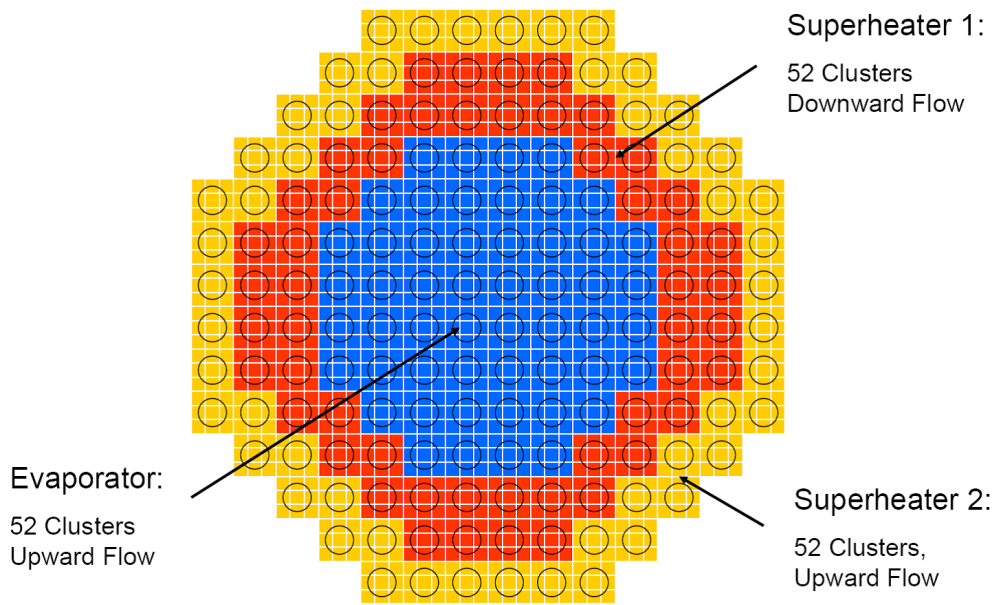

Fig. 2. Arrangement of evaporator and assembly clusters in the core

Beyond 390°C, the coolant density is less than 200kg/m³, hardly enough to produce a thermal neutron spectrum. Therefore, colder feedwater is foreseen as moderator water to run inside moderator boxes in the fuel assemblies and in gaps between assembly boxes. With an estimated pressure drop of up to 1 MPa from reactor inlet to its outlet, and with the aim to minimize the mass of structural material in the core to limit the neutron absorption, the fuel assemblies are small, with 40 fuel pins each and a single moderator box in their centre, to enable a small wall thickness of moderator and assembly boxes. To ease handling during maintenance, 9 assemblies are grouped to a cluster each with common head and foot piece. The clusters can be exchanged between evaporator and superheater positions. The fuel rods have an outer diameter of 8 mm with fuel pellets over an active core height of 4.2m. Wire wraps are proposed as spacers to improve coolant mixing in both flow directions. The clusters can be disassembled at their foot piece to exchange single fuel rods for repair. Control rods with B₄C shall be inserted from the top of the core. They run inside 5 of the 9 moderator boxes of each cluster.

For illustration, Fig. 3 (left) shows cut out view of a single fuel assembly. The assembly box and the water box are made of a stainless steel sandwich construction with an internal honeycomb structure filled with Zirconia to improve the thermal insulation and to reach the envisaged stiffness of less than 0.5mm deflection towards the fuel rods under an outside pressure load of 500kPa. Details of the box design are shown in Fig. 3. A venting hole per honeycomb, open to the colder side, is reducing the pressure load acting on the honeycomb structure. The corner pieces are made of solid stainless steel structures to reduce peak stresses there.

The common head piece of a fuel assembly cluster is shown in Fig. 4 in more detail. The steam plenum is mounted over the window element and sealing rings (C-rings) avoid ingress of moderator water into the steam plenum. Moderator water enters into the water boxes through orifices in the top of the head piece, Fig. 4, left. A common spider for 5 control rods can be coupled with the control rod drive. The inner assembly box is welded with the bottom plate of the head piece. It will carry the weight of the foot piece with all assemblies standing on it when the

cluster will be lifted. The other 8 assembly boxes are sliding with their round extensions in the bottom plate of the head piece using piston rings to seal against ingress of moderator water.

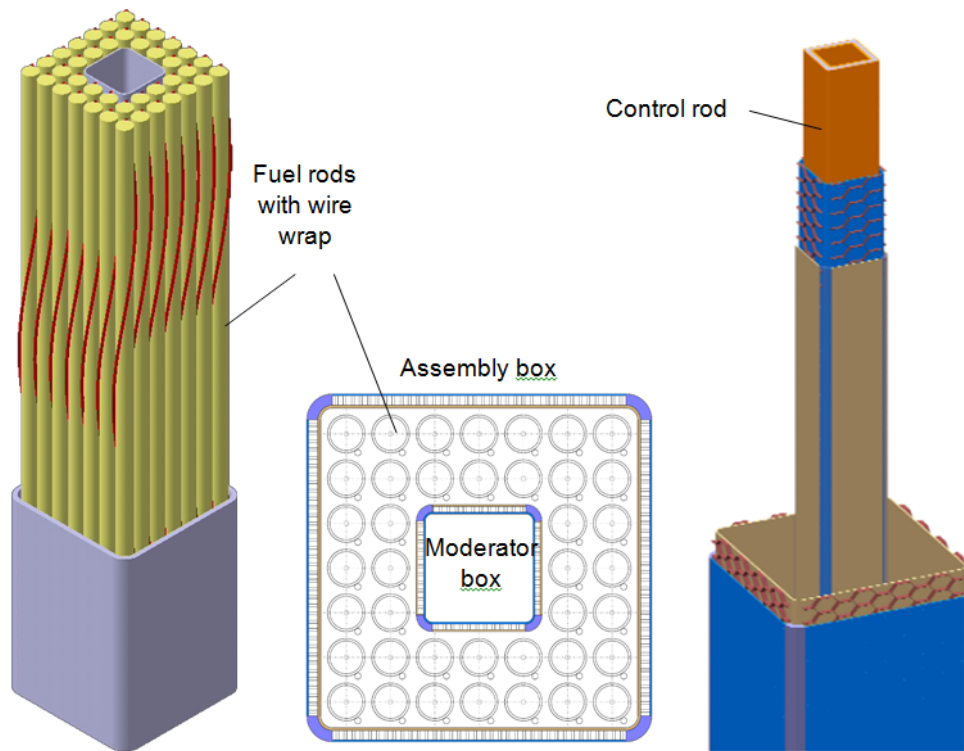

Fig. 3. Assembly design with wire wrapped fuel rods (left) and honeycomb structures of the assembly and moderator box (right). A square control rod is inserted from top.

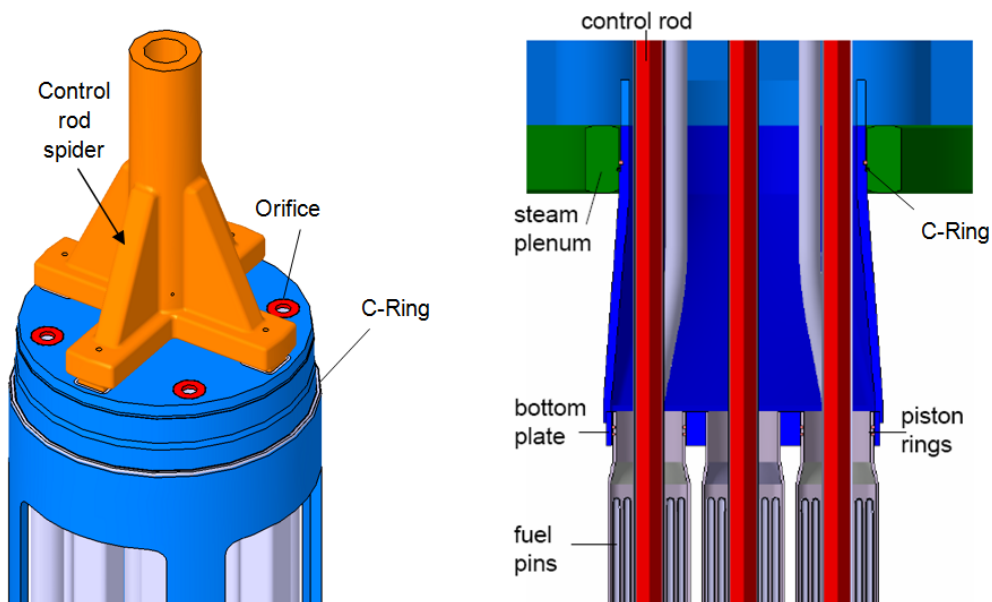

Fig. 4. Head piece of an assembly cluster; cut through assemblies and water boxes

The foot piece is designed with an upper plate, an insert, and a diffuser, which becomes a nozzle in case of the first superheater outlet, as shown in Fig. 5. All but the central assembly box of the cluster are welded with the upper plate. The central assembly box is bolted with 4 screws with the upper plate, instead. Sealing between the upper plate and the central assembly box is provided by sealing lips in both parts which are pressed together by the bolts. All central moderator boxes inside the assemblies are welded with the head piece. Their lower ends are extended with cylindrical tubes which are inserted into the insert of the foot piece, as shown in Fig. 5, left. Piston rings avoid

leakage at these joints. The insert includes a channel system which guides the moderator water horizontally to the exit holes in the diffuser, where the moderator water is released to be mixed with the gap water surrounding the assemblies. Openings for the vertical steam flow, surrounding the insert, are designed as large as possible to minimize pressure losses, but inlet orifices must be added into evaporator clusters to avoid density wave oscillations. The insert of the foot piece and the diffuser are welded together to avoid leakage of cold moderator water into the superheated steam.

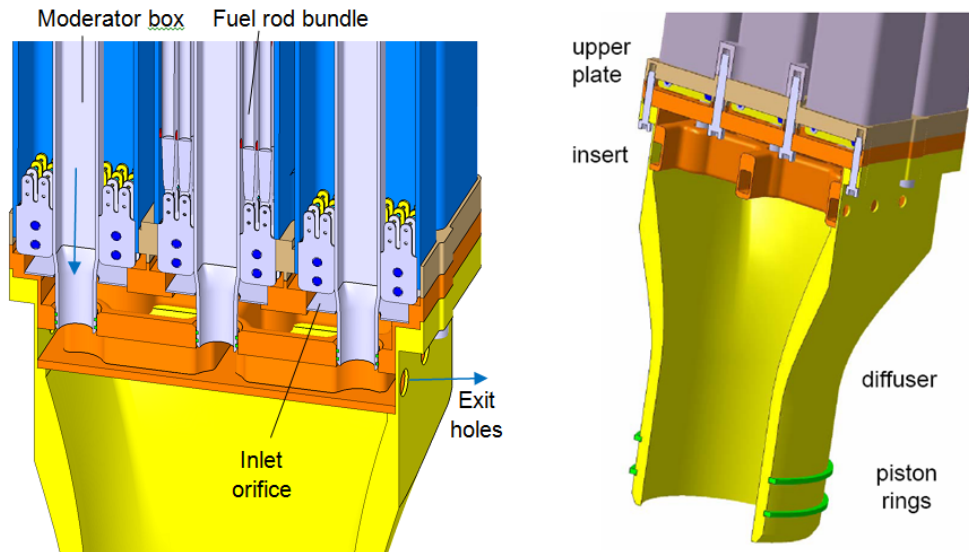

Fig. 5. Foot piece design; cut through assemblies (left) and cut between assemblies (right)

The fuel is UO_2 with an enrichment of 8 to 9% to reach the target burn-up of more than 60 GWd/t_{HM}. Detailed analyses have been performed with an enrichment of 5 to 7%, reaching an average burn-up of 32.5 GWd/t_{HM} [2]. Recycled MOX fuel can be used as alternative [4]. Four Gd rods per assembly with 3w/o Gd_2O_3 compensate the initial excess reactivity. Like in boiling water reactors, soluble neutron absorbers cannot be used. The cycle length is 330 days with an average residence time of the assemblies of 3 years in case of the lower enrichment or 6.5 years in case of the higher enrichment. To keep the peak cladding temperature below the envisaged material limit of 630°C in all heat-up steps, the core power is highest in the evaporator, where more than 1400 MW of the total thermal power of 2300 MW is supplied at the beginning of an equilibrium cycle, whereas the 2nd superheater is producing only around 100 MW. During burn-up, the evaporator power is decreasing as fuel is faster consumed there, so that only 1300 MW are produced there at the end of the cycle, whereas the power of the 2nd superheater is increasing to around 150 MW. The average thermal core power is 57.3 MW/m³.

As a measure to manage the high enthalpy rise of the coolant in the core, an effective coolant mixing inside assemblies and between each heat up step is a key requirement of this core concept. Coolant mixing of moderator water with downcomer water upstream the core inlet is provided by the lower mixing plenum, Fig. 1. Mixing inside assemblies has been optimized using the wire wrap spacers, Fig. 3. The inner part of the steam plenum, Fig. 1, which is separated by walls from its outer part where the superheated steam is collected, has been equipped with walls as flow obstacles to enhance the mixing quality from the evaporator outlet to the 1st superheater inlet. The 1st superheater outlets, running into the annular mixing chamber underneath the core support plate, are equipped with nozzles producing a mixing vortex ring on the coolant flow path into the 2nd superheater.

Description of safety concept

Even though the HPLWR plant concept looks similar to a boiling water reactor (BWR), at a first glance, it differs fundamentally by the missing recirculation pumps. Whereas a control of water inventory in the reactor pressure vessel is sufficient for the BWR to ensure the residual heat removal even in case of severe accidents, a continuous coolant mass flow rate through the reactor is required for this once through steam cycle as there is no closed coolant loop inside the reactor. This can be achieved either with redundant feedwater pumps or by depressurization of the pressure

vessel such that the residual heat is removed by vaporization. For the unlikely case of a severe accident, these functions must also be provided inside the containment. With this respect, most safety systems of the containment can indeed be derived from latest BWR containment concepts, with the exception of passive flooding and emergency condensers for reasons explained above.

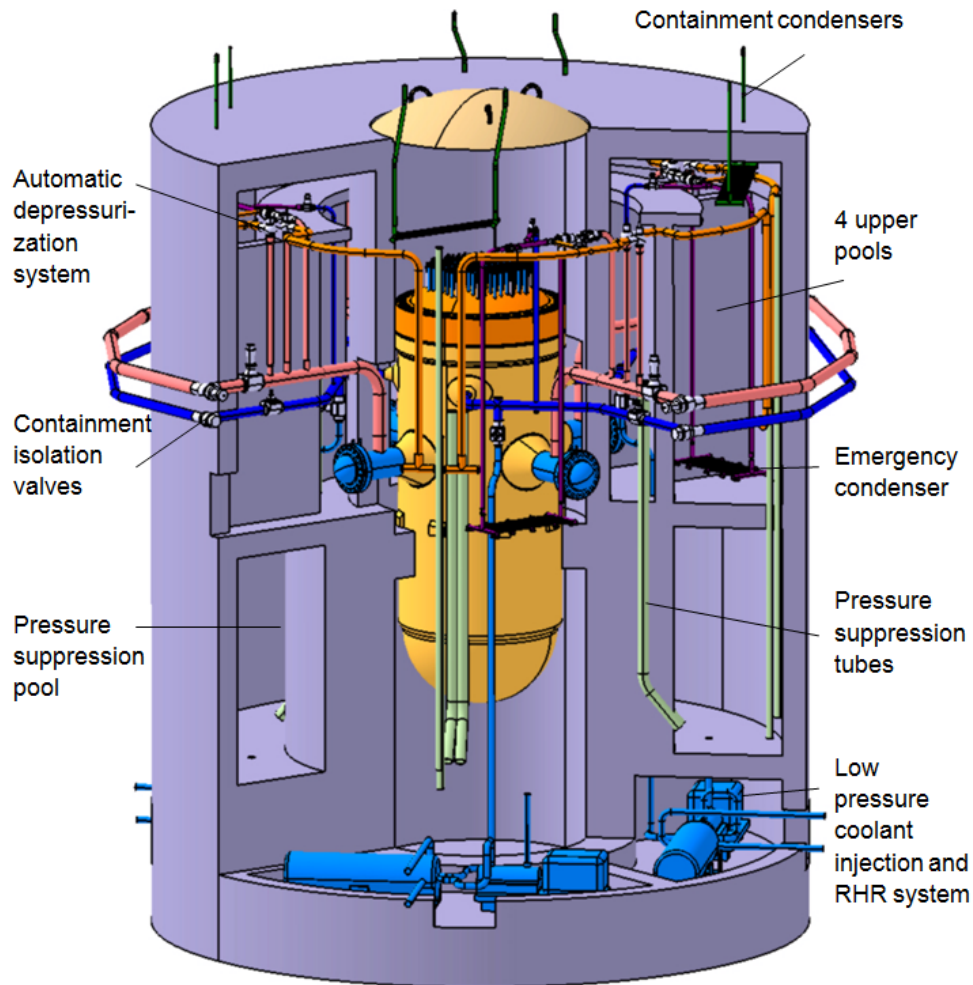

Fig. 6. Containment design with pressure suppression pool, residual heat removal system, low pressure coolant injection system and passive high pressure safety system [2].

A design proposal for the containment is shown in Fig. 6. It is made from reinforced concrete, equipped with an inner steel liner and a pressure suppression system. The design pressure of the containment is considered to be in the range of about 0.3 to 0.4 MPa. Containment isolation valves for each of the 4 feedwater and steam lines, inside and outside of the containment, close automatically in case of a feedwater or steam line break inside or outside the containment. The reactor is scrammed and the depressurization valves release steam through 8 spargers into 4 upper pools, removing the residual heat until at least one of the 4 redundant, active low pressure coolant injection pumps in the basement of the containment becomes available. In case of a steam line break inside the containment, any pressure increase by steam release is limited by a large pressure suppression pool in the lower half of the containment into which 16 open pressure suppression tubes are running. As an additional passive high pressure safety system, de Marsac et al. [5] proposed to use steam injectors to supply feedwater with high pressure from coolers, hanging in the upper pools and driven by steam produced in the core during depressurization. An overflow line to the spargers is starting the steam injectors within the first 10 seconds. This design proposal, however, still needs to be verified. As a back-up alternative to cool down the core at high pressure without steam release to the containment, emergency condensers in the upper pool could be connected with the steam and feedwater lines, supplying the condensate to the core through a motor driven recirculation pump. Long term passive residual heat removal (RHR) from the containment can also be provided by containment condensers to the spent fuel pool above the containment.

The defence in depth strategy is equivalent to conventional light water reactors. Normal operation (DBC1) is controlled by operating systems, which include a conservative design, reliability, availability, and use of proven technology as well as quality assurance. Operational occurrences (DBC2, $>10^{-2}$ /year) are controlled by control and

limitation features like surveillance and diagnostics, and by inherent safety features like a negative void reactivity and by nuclear stability. Design basis accidents (DBC3/4, $>10^{-5}$ /year) are controlled by safety systems, which include 4x redundancy, train separation, protection against internal and external hazards, qualification against accident conditions, automation (<30 min) and autarchy.

TABLE 1. POSTULATED INITIATING EVENTS AND CONCEPT FOR ACCIDENT CONTROL.

Postulated initiating events	Safety functions
<p>Internal events (without loss of coolant)</p> <ul style="list-style-type: none"> • Loss of offsite power • Loss of main heat sink • Loss of feedwater supply • Main steam line isolation • Leaks in main steam line or in main feedwater line outside containment • Anticipated transient without scram 	<ul style="list-style-type: none"> • Reactor shutdown • Main steam line isolation • Automatic depressurization • Low pressure coolant injection and residual heat removal from reactor pressure vessel and containment
<p>External events</p> <ul style="list-style-type: none"> • Earthquake • Airplane crash • Explosion pressure wave • Other natural external events 	
<p>Loss of coolant accidents: leaks and breaks of</p> <ul style="list-style-type: none"> • Main steam line • Main feedwater line • Inadvertently opening of a safety relief valve 	

The most important initiating events together with the relevant accident control measures are indicated in Table 1. Since there is no potential of natural circulation in the current HPLWR design concept in case of incidents or accidents, it is mandatory to continue the coolant flow from outside of the RPV by active or passive means. Therefore, flow control is an essential accident control mechanism which has to be assured in all cases. In case that the containment is isolated, the coolant loop must be closed inside the containment, which means that the depressurization system has to be initiated in all cases in advance, since the injection systems are all designed for lower pressure.

In case of severe accidents, the requirement of prevention of evacuation and relocation of the immediate vicinity of the plant leads to the necessity of maintaining the containment integrity for all essential severe accident phenomena. Therefore design provisions have been implemented into the plant concept, which enable to meet this goal. Table 2 indicates the essential phenomena, the mitigation strategy, the measures and results of the mitigation strategy.

TABLE 2. HPLWR SEVERE ACCIDENT MITIGATION STRATEGY.

The containment is designed to stand	Strategic conditions in Germany	Measure	Results
The containment is designed to stand strategic conditions in Germany earthquake areas, according to DIN 4149.			

A probabilistic risk assessment has not been performed yet.

Proliferation resistance

According to the IAEA Technical Report [6], boundaries must be selected for which guidelines shall be applied. In general, such boundaries can be entire facilities, parts of them, or transportation between them, etc. on coarse or fine level. For the HPLWR, as a first approach, taking the available level of design detail into account, the boundary chosen is the reactor containment, including reactor pressure vessel, spent fuel storage pool, fresh fuel storage room/pool. Not considered, because not HPLWR specific, are the enrichment plant, fuel fabrication and transport, spent fuel transport and interim / final disposal site.

The IAEA report provides the following seven specific design measures to be applied:

1. Data and information collection and transmission

A break in information flow must be treated as a potentially suspicious event which could lead to a process of re-verification, which in turn is very time-demanding and costly. Data collection can be performed through images from optical surveillance inside the containment, results from Cerenkov inspection, seal and confinement integrity and nuclear data from gross gamma measurement or scan, neutron counting, gamma spectroscopy, etc. Being a water cooled reactor, the HPLWR has the advantage that Cerenkov radiation is easy to detect in water and there is a well defined number of fuel assemblies.

2. Identification for fuel assemblies and fuel rods

An identification shall be readable from above in fresh fuel storage area, in spent fuel pool and inside reactor pressure vessel during refuelling (e.g. with small diving cameras). In the current HPLWR design, labeling of the cluster head plate, impossible to remove, and space for an individual serial number are foreseen on all fuel rods.

3. Containment and surveillance

Confinement of fissile material is provided by containment seals. Such sealing systems are foreseen for the spent fuel inventories stored in ponds, spent fuel casks, the reactor core (here the concrete plate covering reactor pit) and for transfer canal gates. Optical surveillance is maintained through cameras mounted in the containment for the spent fuel pool, the reactor closure and for exit doors and hatches.

4. Fresh fuel receiving and storage area

The requirements for fresh fuel receiving and storage area are a minimum number of openings, through which the fuel can enter and leave such a storage area, and a layout to be able to seal groups of fuel assemblies. Provision of adequate space and illumination shall be provided and a minimization of fuel moving in general. Low enriched uranium is foreseen for the HPLWR, which can be stored in a dry storage enabling all measures mentioned above. Grouping of fuel assemblies shall only be handled by means of robotics.

5. Fuel loading and unloading

The requirements for fuel unloading and loading are a suitable mounting for surveillance equipment in containment, by an indexing mechanism on the refuelling machine to identify the fuel assembly position and by provisions for sealing the canal gate. The loading and unloading process shall be observed in the HPLWR by simple optical cameras looking into the water pool.

6. Reactor core

The requirements for the HPLWR core are a suitable arrangement for surveillance and sealing on concrete slabs, a suitable arrangement for surveillance equipment to view the reactor vessel operations when vessel is open and underwater illumination at sufficient water clarity.

7. Spent fuel storage and shipping area

For spent fuel storage and shipping area, the requirements are suitable arrangements for surveillance equipment,

storage racks preferably arranged in a single layer, an indexing system for identification of specific fuel assembly locations, a minimum number of openings through which the spent fuel can be moved, water clarity and provisions to facilitate annual Physical Inventory Verification, i.e. counting, verifying spent fuel attributes by irradiation measurement. The HPLWR can easily fulfil these requirements, because of a low number of fuel assemblies for the HPLWR to be observed, and because the physical inventory is easy to verify under clear water.

Significant quantities of fuel, which must be timely detected in case of diversions, are in case of the HPLWR:

- 670 rods of fresh fuel must be diverted to reach the IAEA limit of 75 kg of U-235.
- About 564 rods of discharged fuel with 32.3 GWd/t_{HM} burn-up or 428 rods with 50.4 3GWd/t_{HM} burn-up must be diverted to reach the IAEA limit of 8 kg Pu.

As shown in Chapter 2, 40 fuel rods form an assembly and nine assemblies are grouped to a cluster. According to the results above, more than one cluster must be diversified and reprocessed in order to exceed the detection limit of the IAEA.

Safety and security (physical protection)

As shown in Fig. 6, all safety systems are arranged in a compact containment made of reinforced concrete. The drywell is filled with nitrogen and not assessable during operation. A total water volume of 2000 m³ inside the containment is serving as a heat sink during the first 8 hours after scram. Even beyond this phase, the passive containment condensers avoid an intolerable increase of the containment pressure by removing the residual heat to the pool above the containment. These long time frames enable a long grace time before operator actions need to be taken.

Several passive components are included in the safety systems, but the active systems still need a control system and a power supply to be operated. Details of the control system or of the emergency diesel generators have not been worked out yet.

Description of turbine-generator systems

Fig. 7 shows a schematic illustration of the HPLWR steam cycle with data for full load operation. Superheated live steam leaves the reactor with a temperature of 500°C at 24 MPa pressure and 1179 kg/s mass flow rate. Before it enters the high pressure (HP) turbine, some live steam is extracted to reheat steam in the counter-current reheater. Most of the steam (82.2 % of the total mass flow rate) is expanded through the HP turbine and reaches the shell side of the reheater with a temperature of 260.2°C at 4.25 MPa pressure and, due to the steam extractions in the HP turbine, with 824 kg/s mass flow rate. There, it is reheated with the live steam from the reactor (494°C; 22.6 MPa; 209.5 kg/s) to 441°C, before it is expanded in the intermediate pressure (IP) and low pressure (LP) turbines to 32.9°C at 5 kPa pressure with a steam quality of 0.87.

The technology of the turbines is based on the turbines of supercritical fossil-fired power plants. Like there, full speed turbines and generator can be applied for the HPLWR concept. A double flow HP turbine is needed, which is usually not used in fossil fired power plants because of lower mass flow rates, but could be designed and manufactured for this purpose with available technologies. A double flow IP turbine and three double flow LP turbines are needed for a condenser pressure of 5kPa; the size is comparable to those of supercritical fossil fired power plants [7].

The HPLWR concept requires a 320 MW high pressure turbine with a reheat pressure of 4.25 MPa. Reheat at this pressure avoids condensation in the HP turbine. Compared to supercritical fossil fired power plants, pressures and temperatures are slightly lower. The first blading group of the HP turbine consists of twelve stages and the second blading group of five ones. The minimum blade span amounts 48 mm and the maximum blade span is 139 mm; the rotor diameter at the last stages is 840 mm. The blades and vanes of the diagonal inlet stage as well as the blades and guide vanes of the first and second blading drum are made of X20Cr13, a ferritic-martensitic steel. The double flow HP turbine has a bearing clearance of 6500 mm and a weight of approximately 180 t.

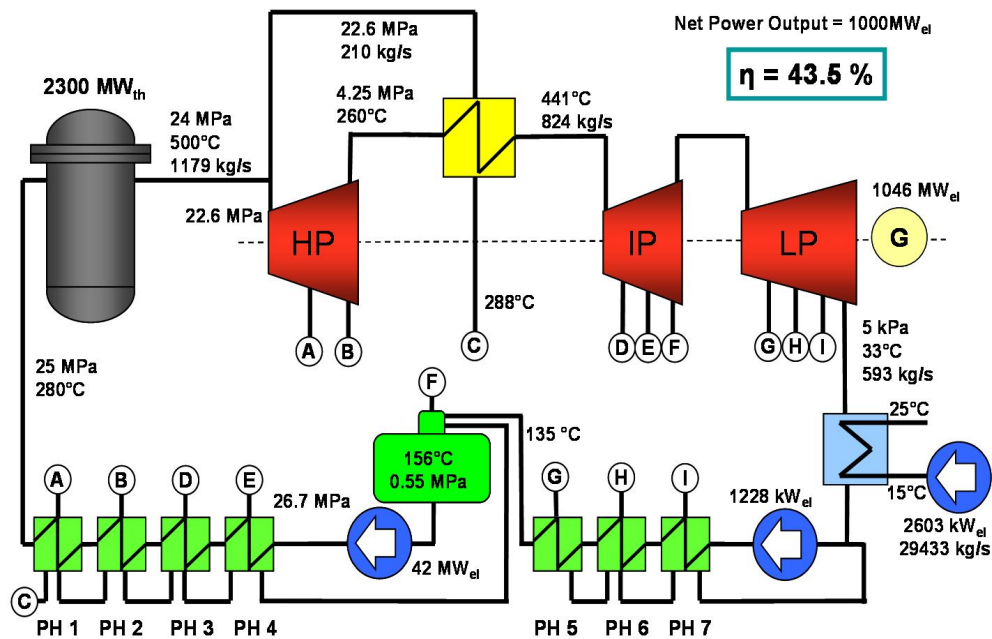

Fig. 7. Heat flow diagram of the HPLWR steam cycle [8]

For the IP turbine, a unit comparable with those of supercritical fossil fired power plants can be implemented. The turbine is a double flow unit with asymmetric extractions at different pressures, including blade heights from 137 mm to 287 mm and a rotor with 1200 mm diameter at the last stages. Ten stages are needed for generator side flow, and nine stages are housed on the HP turbine side. On the generator side, the extraction is placed after the seventh stage and on the HP turbine side steam is taken out after the fourth stage. The blades and guide vanes are made of X20Cr13. The IP unit has a bearing clearance of 7000 mm and a weight of approximately 200 t.

Each component of the six-flow LP turbines contains seven stages with blades heights from 58 mm at inlet to 1145 mm at the outlet. Three independent casings are foreseen. Extractions are placed after the second and fourth stage; vanes and blades are made of X20Cr13. Each of the three LP turbines has a bearing clearance of 9200 mm and an estimated weight of 350 t. The last-stage blading of the LP turbine has an axial exhaust area of up to 12.5 m², and the steam quality amounts to 0.87%. Therefore, heating of the last guide vanes in the LP turbine is not necessary.

A standard 1000 MW THDF non-speed reduced SIEMENS generator with a water cooled stator and a hydrogen cooled rotor is recommended. SIEMENS generators are highly reliable and reach an efficiency of 99%. The generator including exciter has a bearing clearance of ca. 20000 mm and its diameter quantifies 1.3 m.

In the condenser, feedwater is slightly sub-cooled by the main heat sink, which is driven by the cooling circuit pump that consumes 2603 kW_{el} to pump a mass flow of 29433 kg/s. From there the feedwater leaves the condenser sump, where it is mixed with the condensate of the first LP preheater PH 7 at 31°C. Before it enters the LP preheaters, the pressure is levelled up to 1.35 MPa by the condensate pump, which consumes 1228 kW_{el} in total. In the three LP preheaters, which are fed by steam extractions from the LP turbine, the temperature is raised to 135°C with which it enters the feedwater tank. Feedwater leaves the tank with a temperature of 156°C due to the higher temperature of the condensate cascade of the HP preheaters and the steam extraction of the IP turbine. The pressure is raised after leaving the feedwater tank to 26.7 MPa with the main feedwater pump, which consumes 42 MW_{el}.

In four HP preheaters, the feedwater is heated up to 280°C core inlet temperature with the several steam extractions from the IP and HP turbines and the waste steam of the reheater, respectively, which is led as condensate into the preheater PH 1. The core inlet pressure decreases to 25 MPa due to the pressure drop of pipings and the four HP preheaters. With a thermal power of the reactor of 2300 MW_{th}, a gross power output of 1046 MW_e is obtained. The net efficiency amounts 43.5%.

The steam cycle is operated at a fixed pressure of 25 MPa at core inlet. A sliding pressure start-up with two-phase flow at sub-critical pressure has been avoided because of the risk of high fuel cladding temperatures under post dryout conditions. Instead, a constant pressure operation from start-up to full load has been foreseen. If the thermal power of the core is decreased below 50% load, with constant mass flow rate to avoid flow reversal in the three pass core, the reactor outlet temperature decreases, which would result in a steam expansion into the two-phase region of the HP

turbine, with the risk of erosion of the HP turbine blades. Therefore, the steam turbines are disconnected in this load range below 50% and the steam is expanded instead in a combined start-up and shut down system, comprising a battery of steam separators and dryers in the turbine building [9].

Electrical and I&C systems

Electrical and I&C systems have not been designed yet for the HPLWR.

Spent fuel and waste management

Due to the higher net efficiency of the HPLWR of 43.5% vs. around 36% of a second generation PWR, the consumption of natural uranium is generally lower. However, the higher enrichment of fuel of around 8% to 9%, which is required to compensate neutron absorption in the stainless steel claddings and assembly boxes to reach a burn-up of more than 60GWd/t_{HM}, is leaving more than 2% residual U-235 in the spent fuel, making this reactor concept rather suitable for a closed fuel cycle.

If a once through fuel cycle will be chosen, the activity and heat generation of spent HPLWR fuel will not differ significantly from spent fuel of a PWR with similar discharge burn-up. As an example, Fig. 8 shows a comparison of the heat generation rate of spent HPLWR fuel and spent VVER-440 fuel.

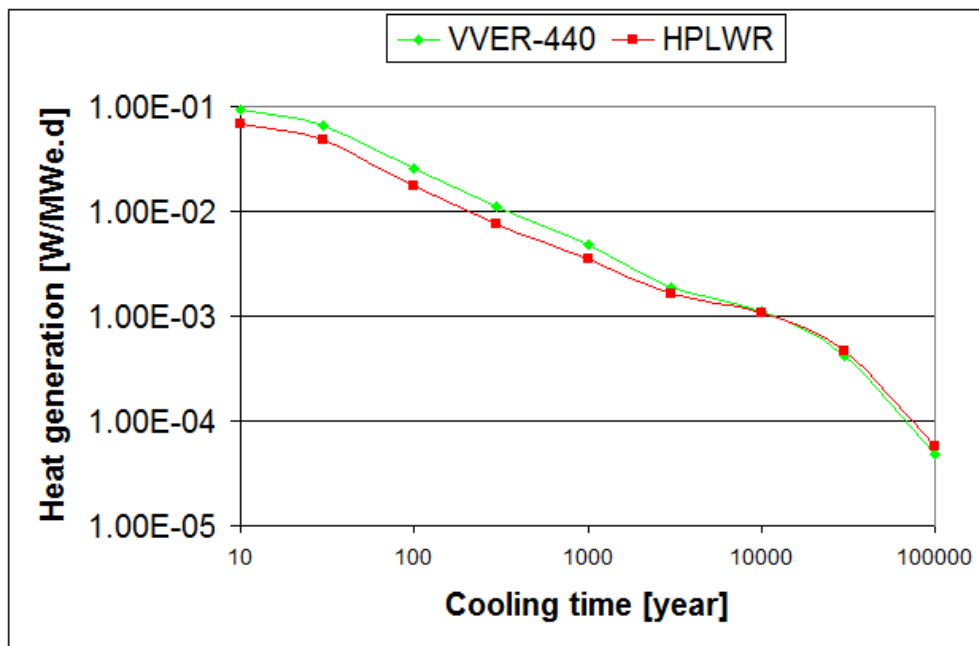

Fig. 8. Heat generation of spent HPLWR fuel and spent VVER-440 fuel, for comparison [2].

Plant layout

A section through the reactor and turbine building is shown in Fig. 9. The reactor building encloses the containment, the lower equipment compartments and safety-related mechanical, electrical and I&C components and systems including their auxiliary systems. The main function of the reactor building is to protect all safety-related equipment against the effects of natural and external man-made hazards. The reactor building also guarantees confinement of radioactivity as the last barrier, preventing the release of radioactive material to the outside atmosphere upon occurrence of a beyond-design event, as a secondary containment. Therefore, components with a high radioactive inventory are placed within the reactor building.

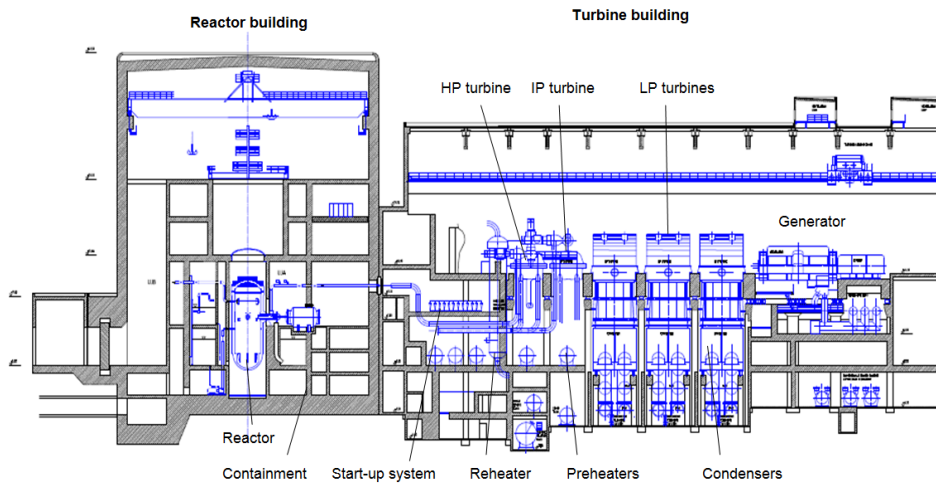

Fig. 9. Section through the HPLWR reactor and turbine building [10]

The reactor building concept is divided into three parts, as follows:

- Outer shell with penetration protection,
- Inner structure, which is largely decoupled from the outer shell,
- Containment, which is disconnected from the reactor building inner structures except for the slabs in the area of main steam and feedwater piping that are connected to the outer shell.

The reactor building has a diameter of 45 m, a height of 55 m, and a volume of approx. 90,000 m³.

The turbine building contains mainly the systems and components of the steam, condensate and feedwater cycle, with condensate and feedwater pumps and feedwater preheaters as well as the turbine generator. The turbine building is part of the controlled area of the plant.

The main parameters of the turbine building are a length of approx. 95 m, a width of approx. 45 m, and a volume of approx. 250,000 m³. The length of the building is mainly determined by the turbine-generator set, while the width is determined by the LP turbine including the condenser withdrawal length and the preheater pump arrangement.

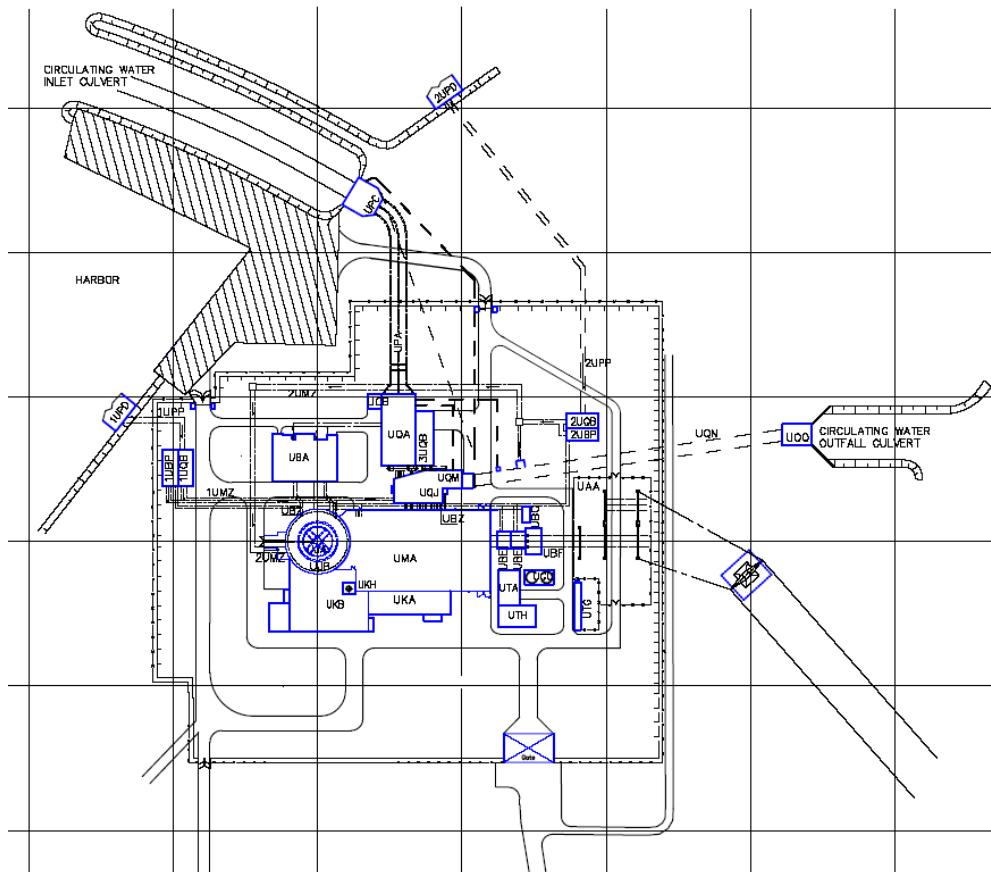

Fig. 10. General plot plan [10]

The general plot plan is shown in Fig. 10 for a seawater site. The buildings shown in the plot plan are as follows: Reactor building (UJB), reactor containment (UJA), waste building (UKA), reactor supporting systems building (UKB), switchyard (UAA), switchgear building (UBA), offsite system transformer (UBC), auxiliary power transformer (UBE), generator transformer (UBF), emergency diesel generator building (UBP), duct structures (cables) (UBZ), emergency control room building (CB), structure for demineralized water tanks (UGC), vent stack (UKH), turbine building (UMA), duct structure (piping) (UMZ), circulating water intake culvert (UPA), circulating water intake structure (UPC), service water intake structure (UPD).

Plant performance

The HPLWR has never been built or operated, and realistic targets on reliability cannot yet be given. With one outage for fuel shuffling per year, the planned availability shall be around 91%.

The envisaged savings of capital costs of around 20% compared with conventional LWR can be estimated from the following size comparison of major components:

Table 3 compares some quantitative cost indicators like volumes of containments and mass of the primary system. Two modern nuclear power plants in Germany, BWR Gundremmingen and PWR in Neckarwestheim GKN2 are selected here for a comparison with the HPLWR.

TABLE 3. QUALITATIVE COST INDICATORS COMPARING THE HPLWR WITH EXISTING LWR

		PWR	BWR	HPLWR

Net electric power	MW _e	1400	1344	1000
Steel masses				
- RPV	t	370	785	656
- Closure head	t	116	incl.	122
- Steam generator	t	490	0	0
- No. of Steam Gen.		4	0	0
- Recircul. Pumps	t	100	3	0
- No. of Rec. Pumps		4	8	0
Total steel mass	t	2846	809	778
	t / MW _e	2.03	0.60	0.78
Total volume of the containment	m ³	65450	22931	9051
	m ³ / MW _e	46.75	17.06	9.05
Mass of turbine train	t	2860	2860	1430
	t / MW _e	2.04	2.13	1.43

The first indicator discussed here is the steel mass on the nuclear system. For the reference PWR, the main components, reactor pressure vessel (RPV) and its closure head, the four steam generators and the four main circulation pumps have been selected. Summing up the weights, a specific indicator of 2.03 t steel/ MW_e can be obtained for these components. For the reference BWR, a value of 0.6 t steel/ MW_e can be calculated. Steam generators of the BWR are included in the RPV and the internal recirculation pumps are light weighted compared with the PWR. For the HPLWR, a value of 0.78 t steel / MW_e has been predicted. It has neither a steam generator, nor recirculation pumps, but the 25 MPa pressure require a certain wall thickness resulting in a total mass of the RPV and closure head of 778t. In this comparison, the BWR has some advantages compared with the HPLWR.

The second cost indicator is the volume of the containment. The volumes are taken from Fig. 9 and provide a maximum value of the total inner volume. The reference PWR has a ratio of 46.75 m³ / MW_e, whereas the reference BWR with 17.06 m³ / MW_e and the HPLWR with 9.05 m³ / MW_e provide smaller numbers. It must be mentioned

here that the comparison of a pressure suppression containment (BWR) with a containment which can be pressurized (PWR) is not really fair, but it shows that a cost reduction already took place with the development of BWR containments. The HPLWR ratio is even smaller than the BWR one which shows a significant advantage of this concept. Smaller containments require less concrete and steel, which has a positive effect on cost savings.

The third indicator is the ratio of the turbine mass and the electric power. According to Herbell et al. [7], the mass of the HPLWR turbine is about half the mass of existing reference plants. The resulting cost indicators show also an advantage of the specific power of the HPLWR turbine (1.43 t / MW_e), which is mainly caused by using a full speed turbine for the HPLWR instead of half speed turbines (being larger) for the reference power plants (PWR: 2.04 t / MW_e; BWR: 2.13 t / MW_e).

For an estimated realistic core design, which may require an enrichment of about 8% U-235, the fuel cycle cost are calculated to be about 0.8 €cent/kWh. Compared to the value of about 0.6 €cent/kWh calculated for a typical LWR, these fuel cycle costs are considered to be higher but acceptable knowing the minor importance of fuel costs for nuclear power at all. A parametric analysis showed that the largest influence on the fuel cycle costs results from the enrichment and the uranium ore cost [2], whereas the fuel fabrication costs are of minor importance with respect to the fuel cycle costs.

Development status of technologies relevant to the NPP

Key technologies for this reactor concept are suitable in-core materials and a reliable prediction of neutronic and thermal-hydraulic phenomena under supercritical water conditions, as summarized in [2].

As part of the above mentioned HPLWR project, sixteen candidate materials were selected to be investigated in autoclaves with respect to their corrosion resistance under supercritical water conditions at temperatures up to 650°C. Ferritic-martensitic steels showed the highest corrosion rate, which was not acceptable. A medium rate was found for the stainless steels, and the lowest rate was found for Ni-based alloys, which are not applicable, however, because of high neutron absorption and associated activation. Four stainless steel materials were selected to investigate stress corrosion cracking (SCC). The result was that the stainless steel BGA4 showed a considerable amount of stress corrosion cracking, compromising its good corrosion resistance, whereas 347H and 1.4970 were less susceptible to SCC. Regarding creep, stainless steel 1.4970 showed the best creep strength, with only little effect of the supercritical water environment on the creep strain rate. Summarizing, the material tests revealed that stainless steel 1.4970 is a suitable material for thick wall components. For thin walled components, in particular the cladding of fuel rods, no material has been found yet which satisfies the target temperature of 630°C with an acceptable corrosion rate. Instead, the tests indicated that a cladding material limit of only 550°C would be acceptable for thin walled components today.

Heat transfer of supercritical water in tubes or annuli can be predicted with a number of correlations or with a look-up table, as long as the heat transfer does not deteriorate at high heat flux and low mass flux close to the pseudo-critical point. In the latter case, as well as in the case of flow in rod bundles, a low Reynolds CFD analysis with a fine resolution of the boundary layer of $y^+ < 1$ can predict at least the onset of heat transfer deterioration. A precise prediction of temperature peaks occurring at deteriorated heat transfer, however, will still need further improvements in turbulence modeling of supercritical water.

As supercritical water, as coolant and as moderator, changes its density significantly in the core, the prediction of the neutron flux distribution needs to be coupled with thermal-hydraulic predictions. Such coupled codes are available now for steady state analyses, where both codes, for neutronics and for thermal-hydraulics, are run iteratively until a consistent, converged solution has been reached. The physical properties and scattering cross sections of supercritical water have been included. Transient core analyses still suffer either from numerical problems during depressurization transients, when the critical point appears in the fluid domain, or they are missing 3D neutron kinetics, taking local coolant temperature transients into account. Thus, transient codes which are optimized for supercritical water cooled reactors are still under development.

Deployment status and planned schedule

So far, all design details shown here are only results of a conceptual design study performed in the European project HPLWR Phase 2, as explained in chapter 1. None of the components have ever been tested, nor is any detailed

design available yet. In general, however, most components of the HPLWR power plant, except the core, can be derived from proven LWR design or from proven fossil fired power plants with supercritical steam conditions. New technologies are required primarily for core design. The biggest uncertainties there are caused by heat transfer predictions, in particular in the evaporator region with high linear power, and by material properties of the stainless steel claddings under supercritical water conditions. Some realistic in-pile material and fuel assembly tests at supercritical water conditions will be needed to reduce these uncertainties to acceptable limits. Moreover, the safety concept includes some new features which must be validated by integral tests. As supercritical water has never been used for nuclear power plants before, at least a small scale prototype will be needed to validate the general approach taken. Research and development is on-going in the Generation IV International Forum in the frame of the joint development program for Supercritical Water Cooled Reactors.

The long term deployment plan is still under discussion. Different from other Generation IV Nuclear Systems, the Supercritical Water Cooled Reactor can also be developed evolutionarily from current pressurized water reactors or from boiling water reactors. Such incremental approach will allow to use proven components and technologies to a large extent, and thus to minimize the technical and financial risks of further development. Accordingly, the strategic research agenda of the Sustainable Nuclear Energy Technology Platform [11] is regarding the SCWR rather as a long term target for further, continuous performance improvements of current light water reactors. The concept shown here should be considered, with respect to this research agenda, as an example to illustrate the future potential of light water reactors, rather than a design to be realized in near future. As a consequence, the concept is currently not yet offered by the nuclear industry.

The following companies and institutions have been involved in the conceptual design study of the HPLWR:

- Karlsruhe Institute of Technology, Institute for Nuclear and Energy Technologies, Germany (Coordinator)
- AREVA NP GmbH, Erlangen, Germany
- Commissariat à l'Énergie Atomique, France
- Hungarian Academy of Science KFKI, Atomic Energy Research Institute, Hungary
- Paul Scherrer Institute, Switzerland
- VTT Technical Research Centre of Finland
- Nuclear Research and Consultancy Group, The Netherlands
- Research Centre Rez, Czech Republic
- Kungliga Tekniska Högskola, Stockholm, Sweden
- University of Stuttgart, IKE, Germany
- Budapest University of Technology and Economics, Hungary
- University of Delft, The Netherlands
- European Commission, Joint Research Centre Petten, The Netherlands.

References

1. J. Starflinger, T. Schulenberg, P. Marsault, D. Bittermann, C. Maraczy, E. Laurien, J.A. Lycklama, H. Anglart, N. Aksan, M. Ruzickova, L. Heikinheimo, European research activities within the project. 'High Performance Light Water Reactor Phase 2' (HPLWR phase 2). Int. Conf. on Advances in Nuclear Power Plants (ICAPP 2007), Nice, France, May 13-18, 2007
2. J. Starflinger, T. Schulenberg, P. Marsault, D. Bittermann, E. Laurien, C. Maraczy, H. Anglart, J.-A. Lycklama, M. Andreani, M. Ruzickova, T. Vanttola, A. Kiss, M. Rohde, R. Novotny, High Performance Light Water Reactor Phase 2, Public Final Report – Assessment of the HPLWR Concept, 6th Framework Programme, Contract No. FI60-036230, 2010, www.hplwr.eu
3. T. Schulenberg, J. Starflinger, J. Heinecke, Three pass core design proposal for a high performance light water reactor, Progress in Nuclear Energy 50 (2008) 526-531
4. W. Bernat, Comparison of UO₂ and MOX fuel for a Supercritical Light Water Reactor, 5th Int. Symp. on SCWR (ISSCWR-5), Vancouver, British Columbia, Canada, March 13-16, 2011
5. B. de Marsac, D. Bittermann, J. Starflinger, T. Schulenberg, Containment design proposal with active and passive safety systems for a High Performance Light Water Reactor, 4th Int. Symp. on SCWR, Paper 10, Heidelberg, Germany, March 8-11, 2009
6. International Atomic Energy Agency, Vienna, Design measures to facilitate implementation of safeguards at future nuclear power plants, IAEA Technical Report 392, 1998.
7. H. Herbell, M. Wechsung, T. Schulenberg, A turbine design concept for the High Performance Light Water

- Reactor, 4th Int. Symposium on SCWR, Heidelberg, Germany, March 8-11, 2009, Paper 76
8. M. Brandauer, M. Schlagenhauer, T. Schulenberg, Steam cycle optimization for the HPLWR, 4th Int. Symposium on SCWR, March 8-11, 2009 Heidelberg, Germany Paper 36
 9. Schlagenhauer, M., Starfinger, J., Schulenberg, T., Plant control of the High Performance Light Water Reactor, Proc. GLOBAL 2009, Paris, France, Sept. 6-11, 2009, Paper 9339
 10. D. Bittermann, S. Rothschnitt, J. Starfinger, T. Schulenberg, Reactor and turbine building layout of the high performance light water reactor, Jahrestagung Kerntechnik, Berlin, May4-6, 2010, Berlin : INFORUM GmbH, 2010 Paper 1216
 11. Strategic Research Agenda, Sustainable Nuclear Energy Technology Platform, www.snetp.eu, 2009

Technical data

General plant data

Reactor thermal output	2300 MWth
Power plant output, gross	1046 MWe
Power plant output, net	1000 MWe
Power plant efficiency, net	43.5 %
Mode of operation	Load follow
Plant design life	60 Years
Plant availability target >	91 %
Primary coolant material	Light Water
Secondary coolant material	Light Water
Moderator material	Light water
Thermodynamic cycle	Rankine
Type of cycle	Direct

Safety goals

Core damage frequency <	1E-5 /Reactor-Year
Large early release frequency <	1E-6 /Reactor-Year
Occupational radiation exposure <	0.5 Person-Sv/Ry

Nuclear steam supply system

Steam flow rate at nominal conditions	1179 Kg/s
Steam pressure	24 MPa(a)

Steam temperature	500 °C
Feedwater flow rate at nominal conditions	1179 Kg/s
Feedwater temperature	280 °C

Reactor coolant system

Primary coolant flow rate	1179 Kg/s
Reactor operating pressure	25 MPa(a)
Core coolant inlet temperature	310 °C
Core coolant outlet temperature	500 °C
Mean temperature rise across core	190 °C

Reactor core

Active core height	4.2 m
Equivalent core diameter	3.5 m
Average linear heat rate	9.75 KW/m
Average fuel power density	26.3 KW/KgU
Average core power density	57.3 MW/m ³
Fuel material	UO ₂
Cladding material	Stainless Steel
Outer diameter of fuel rods	8 mm
Rod array of a fuel assembly	Square
Number of fuel assemblies	1404
Number of fuel Elements in fuel assemblies	156
Enrichment of reload fuel at equilibrium core	9 Weight %
Fuel cycle length	11 Months
Average discharge burnup of fuel	60 MWd/Kg
Burnable absorber (strategy/material)	Gd ₂ O ₃
Control rod absorber material	B ₄ C

Reactor pressure vessel

Inner diameter of cylindrical shell	4465 mm
Wall thickness of cylindrical shell	446 mm
Base material	20MnMoNi 5 5
Total height, inside	13590 mm

Transport weight 656 t

Primary containment

Type Pre-stressed concrete

Overall form (spherical/cylindrical) Cylindrical

Dimensions - diameter 20 m

Dimensions - height 23.7 m

Design pressure 0.5 MPa

Design temperature 150 °C

Design leakage rate 0.5 Volume % /day

Residual heat removal systems

Active/passive systems Active and passive systems

Safety injection systems

Active/passive systems Active

Turbine

Type of turbines Steam, condensing-extraction

Number of turbine sections per unit (e.g. HP/MP/LP) 1/1/3

Turbine speed 3000 rpm

HP turbine inlet pressure 24 MPa(a)

HP turbine inlet temperature 500 °C

Generator

Type Siemens THDF

Rated power 1300 MVA

Active power 1100 MW

Voltage 27 kV

Frequency 50 Hz

Condenser

Type Single pressure surface condenser
Condenser pressure 5 kPa

Feedwater pumps

Number 4
Head at rated conditions 3000 m
Flow at rated conditions 0.45 m³/s