

60 Years of Marine Nuclear Power: 1955 – 2015

Part 2: United States

Peter Lobner
December 2015

Foreword

This is Part 2 of a rather lengthy presentation that is my attempt to tell a complex story, starting from the early origins of the U.S. Navy's interest in marine nuclear propulsion in 1939, resetting the clock on 17 January 1955 with the world's first "underway on nuclear power" by the *USS Nautilus*, and then tracing the development and exploitation of nuclear propulsion over the next 60 years in a remarkable variety of military and civilian vessels created by eight nations.

I acknowledge the great amount of work done by others who have posted information on the internet on international marine nuclear propulsion programs, naval and civilian nuclear vessels and naval weapons systems. My presentation contains a great deal of graphics from many internet sources. Throughout the presentation, I have made an effort to identify all of the sources for these graphics.

If you have any comments or wish to identify errors in this presentation, please send me an e-mail to: PL31416@cox.net.

I hope you find this presentation informative, useful, and different from any other single document on this subject.

Best regards,

Peter Lobner
August 2015

United States

- Current nuclear vessel fleet
- Naval nuclear infrastructure
- U.S. naval reactors and reactor prototype facilities
- Navy nuclear submarines:
 - Fast attack subs (SSN)
 - Strategic ballistic missile subs (SSBN)
 - Cruise missile subs (SSGN)
 - Special operations subs
- Navy nuclear surface ships:
 - Cruisers
 - Aircraft carriers
- Nuclear vessel decommissioning and environmental cleanup
- Civilian nuclear marine vessels & reactors
 - Merchant ship & floating nuclear power plant
- Radioisotope Thermoelectric generators (RTGs) at sea
- Marine nuclear power current trends

U.S. current nuclear vessel fleet

mid-2015

- The U.S. Navy operates an all-nuclear fleet of submarines comprised of 72 vessels in the following classes:
 - 39 x Los Angeles-class SSNs in three sub-classes (9 x 688 Flight I; 8 x 688 Flight II, and 22 688i)
 - 3 x Seawolf-class SSNs, including the special operations sub SSN-23, *Jimmy Carter*
 - 12 x Virginia-class SSNs in three sub-classes (4 x VA Block I; 6 x VA Block II; and 2 x VA Block III)
 - 14 x Ohio-class SSBNs
 - 4 x Ohio-conversion SSGNs
- The U.S. Navy operates a fleet of nuclear-powered aircraft carriers, currently all from one class:
 - 10 x Nimitz-class CVNs
 - The first Gerald R. Ford-class CVN is expected to enter service in late 2015.
- The U.S. Navy also operates two converted SSBNs as Moored Training Ships (MTS)
- The U.S. does not operate any commercial nuclear-powered vessels.

U.S. naval nuclear infrastructure

RADM Hyman G. Rickover

- 27 January 1900: Born in Poland, just a few months before the U.S. submarine force came into existence.
- Graduated from the Naval Academy in 1922.
- Served as head of Bureau of Ships Electrical Section during World War II.
- Early 1946: Assigned by Bureau of Ships to receive training in nuclear power at Oak Ridge, TN and worked with the Bureau to explore the possibility of nuclear-powered ship propulsion.
- May 1946: Rickover assigned Deputy Director of Oak Ridge nuclear propulsion program
- February 1949: Assigned to the Division of Reactor Development at the U.S. Atomic Energy Commission and also assigned as Director of the Naval Reactors Branch in Bureau of Ships.
- This twin role enabled Rickover to lead the effort to develop the world's first nuclear-powered submarine, USS Nautilus (SSN-571), commissioned in January 1955.
- Promoted to the rank of Vice Admiral by 1958, Rickover exerted tremendous influence over the nuclear Navy in both engineering and cultural ways. His views touched matters of design, propulsion, education, personnel, and professional standards.
- In every sense, he played the role of father to the nuclear fleet, its officers, and its men.
- After sixty-four years of service, Rickover retired from the Navy as a full admiral on 19 January 1982. He died on July 8, 1986.



Rickover aboard Nautilus

Source: US Navy

Executive Order 12344

Naval Nuclear Propulsion, 1 Feb 82

- For the purpose of preserving the basic structure, policies, and practices developed for this Program in the past and assuring that the Program will continue to function with excellence, it is hereby ordered as follows:
 - Naval Nuclear Propulsion Program is an integrated program carried out by two organizational units: Department of Energy & Department of the Navy
 - Both organizational units shall be headed by the same individual so that the activities of each may continue in practice under common management.
- Secretary of Energy shall assign to the Director the responsibility of performing the functions of the Division of Naval Reactors transferred to DOE by Section 309(a) of the Department of Energy Organization Act (42 U.S.C. 7158), including assigned civilian power reactor programs, and any naval nuclear propulsion functions of DOE.
- Secretary of the Navy shall assign to the Director responsibility to supervise all technical aspects of the Navy's nuclear propulsion work.
- The Director's roles & responsibilities include:
 - Direct supervision of Bettis and Knolls Atomic Power Laboratories, the Expanded Core Facility, and naval reactor prototype plants;
 - Research, development, design, procurement, acquisition, specification, construction, inspection, installation, certification, testing, overhaul, refueling, operating practices and procedures, maintenance, supply support, and ultimate disposition, of naval nuclear propulsion plants, including components thereof, and any special maintenance and service facilities related thereto;
 - Safety of reactors and associated naval nuclear propulsion plants, and control of radiation and radioactivity associated with naval nuclear propulsion activities;
 - Training, including training conducted at the naval prototype reactors of DOE and Nuclear Power Schools of the Navy;
 - Administration of the Naval Nuclear Propulsion Program.

Naval Nuclear Propulsion Program (NNPP) Management

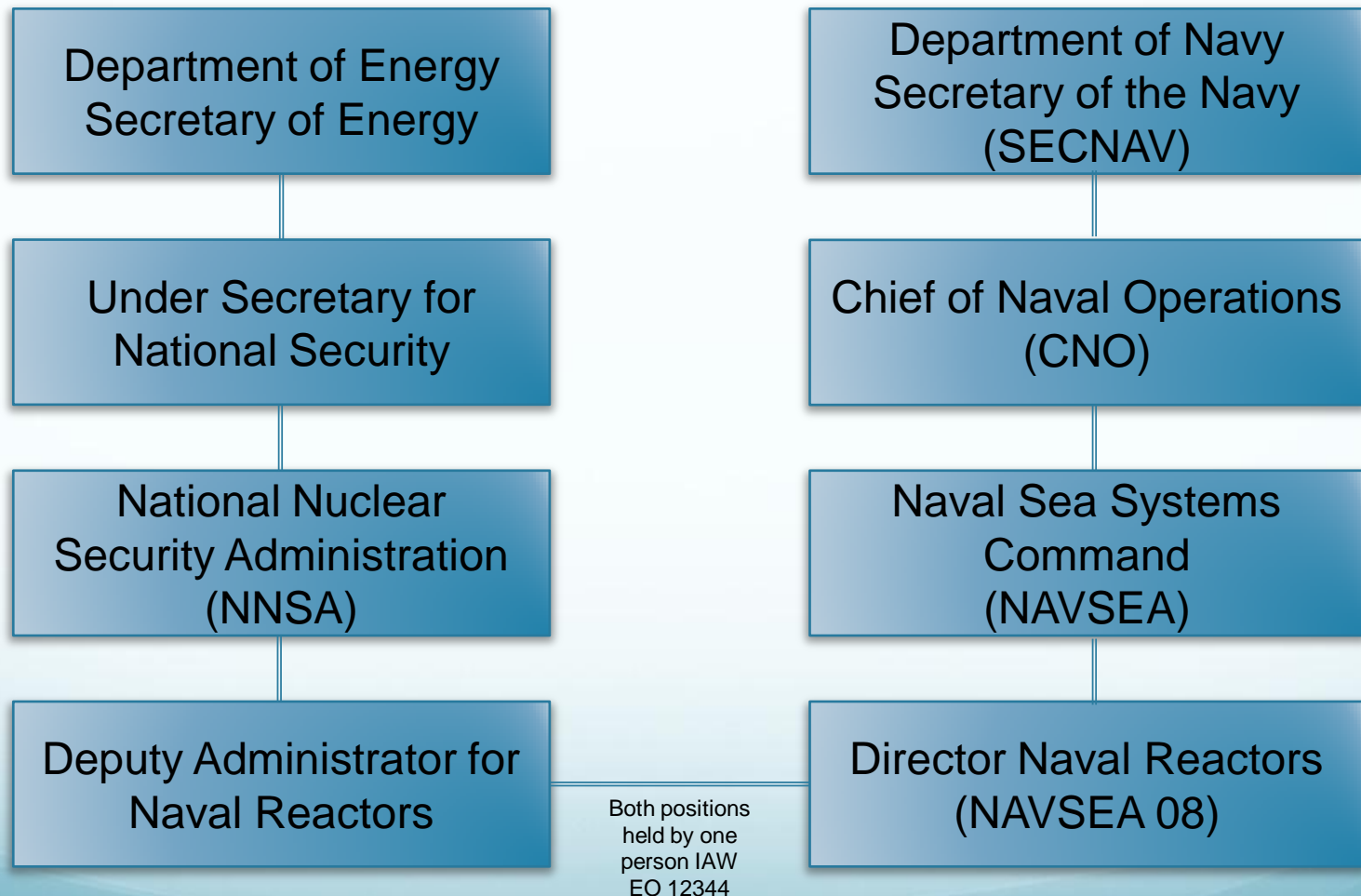

Directors of Naval Reactors

Director of Naval Reactors	Start term	End term
Adm. Hyman G. Rickover	Feb 1949	Feb 1, 1982
Adm. Kinnaird R. McKee	Feb 1, 1982	Oct 22, 1988
Adm. Bruce DeMars	Oct 22, 1988	Sep 27, 1996
Adm. Frank "Skip" Bowman	Sep 27, 1996	Nov 5, 2004
Adm. Kirkland H. Donald	Nov 5, 2004	Nov 2, 2012
Adm. John M. Richardson	Nov 2, 2012	5 Aug 2015, became CNO
Adm. Frank Caldwell	5 Aug 2015	present

Naval Nuclear Propulsion Program (NNPP) Management

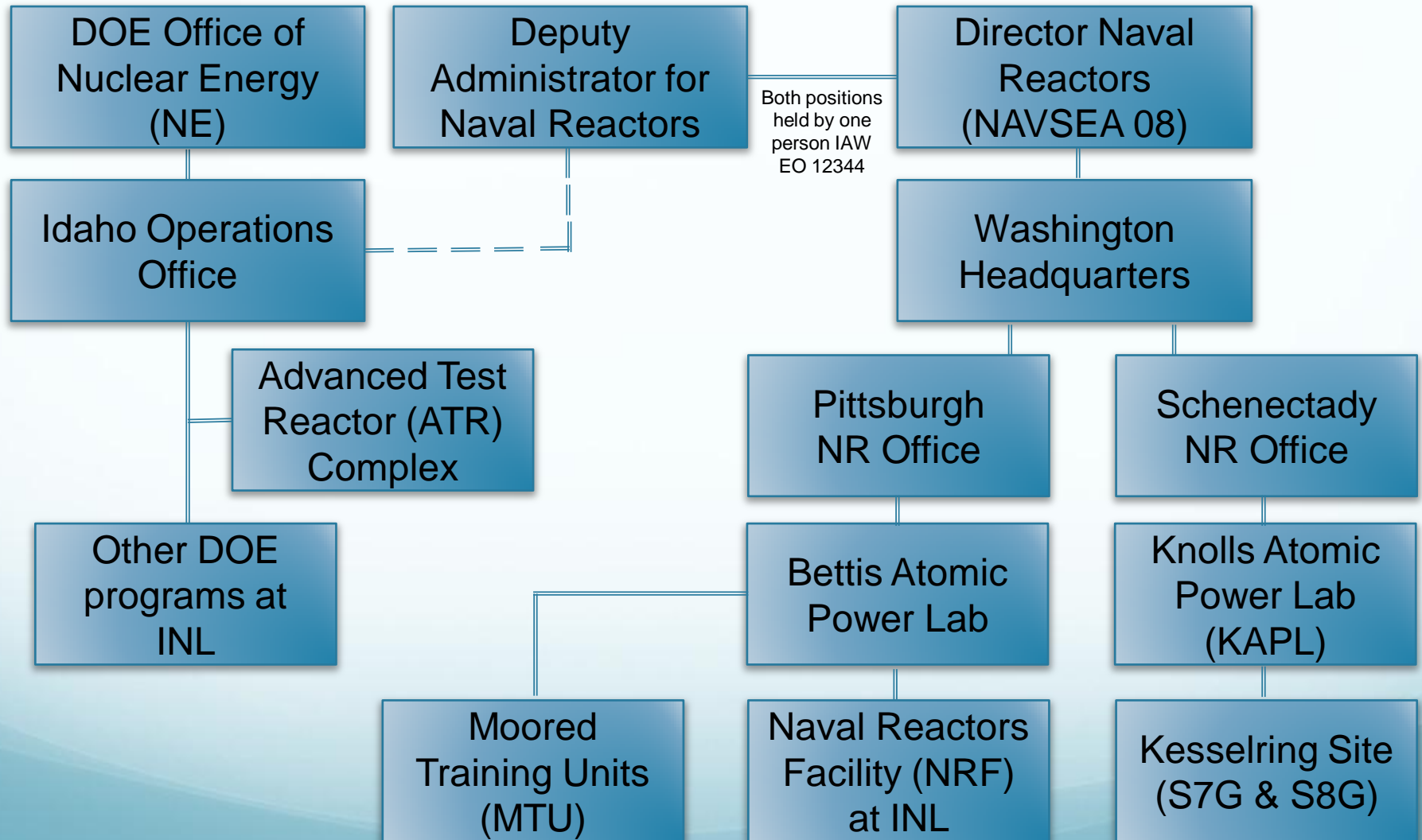

Naval Reactors Organization

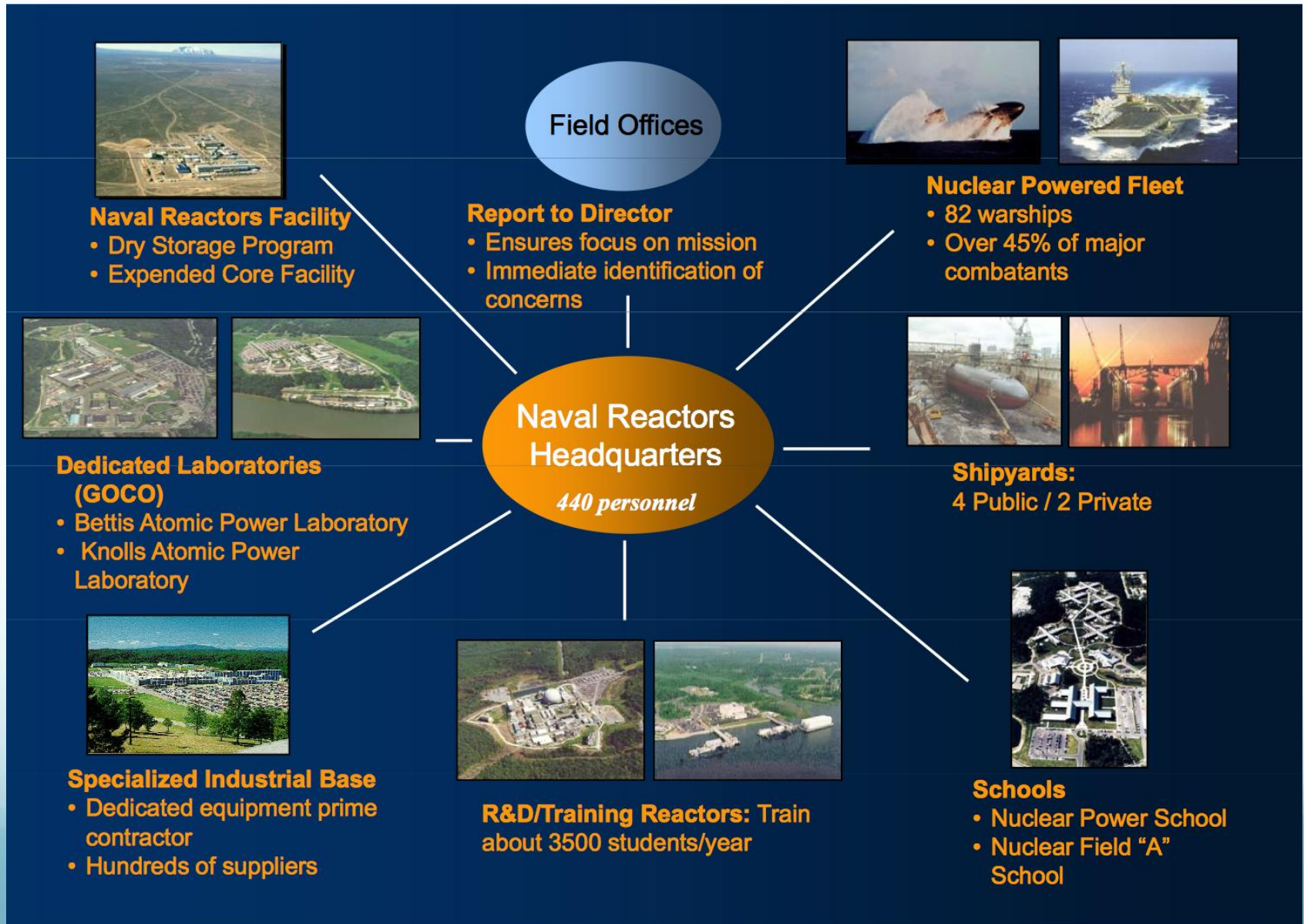

Naval Reactors

2014 budget request

including out-year projections for 2015 - 2018

(Dollars in Thousands)

	FY 2014 Request	FY 2015 Request	FY 2016 Request	FY 2017 Request	FY 2018 Request
Naval Reactors					
Naval Reactors Operations and Infrastructure ^b	455,740	436,180	469,300	480,563	484,316
Naval Reactors Development ^b	419,400	419,000	411,700	416,100	454,300
S8G Prototype Refueling ^b	144,400	128,600	133,000	124,000	190,000
OHIO Replacement Reactor Systems Development ^b	126,400	156,100	177,000	213,700	156,700
Program Direction ^b	44,404	47,400	49,700	52,100	54,700
Construction ^b	69,773	189,820	223,900	359,000	255,400
Subtotal, Naval Reactors	1,260,117	1,377,100	1,464,600	1,645,463	1,595,416
Use of Prior Year Balances	-13,983	0	0	0	0
Total, Naval Reactors	1,246,134	1,377,100	1,464,600	1,645,463	1,595,416

Source: Department of Energy 2014 Congressional Budget Request, DOE/CF-0084, Vol 1.

Knolls Atomic Power Laboratory

- Knolls Atomic Power Laboratory (KAPL) is one of two government-owned, contractor-operated laboratories solely dedicated to naval nuclear propulsion work for Naval Reactors.
- KAPL is located near Schenectady, NY and has been operated by Bechtel Marine Propulsion Corp. since 2009, when Naval Reactors consolidated the management of KAPL and Bettis.
 - 1946: Founded when General Electric received a research contract from the Manhattan Engineering District.
 - 1950: GE started research on small reactors for submarines.
 - 1946 – 1995: General Electric remained the operating contractor
 - 1995 – 2009: Lockheed Martin was the second operating contractor
- KAPL's mission is to help ensure the continued safe and reliable operation of the Navy's nuclear reactor propulsion plants and to develop new reactor plants to meet evolving defense requirements.
- KAPL has fuel manufacturing development capabilities and unique thermal-hydraulic test capabilities.
- KAPL operates two Naval reactor prototypes at the Kesselring Site in West Milton, NY.
 - The prototype reactors are used for operational testing of new technologies under typical operating conditions prior to fleet introduction and for training Navy nuclear operators.
 - The prototypes are MARF/S7G and S8G.
 - Nuclear Power Training Unit (NPTU) Ballston Spa is located at the Kesselring site.

Kesselring Site, West Milton, NY

- Two land-based naval reactor prototypes are operating at KAPL's Kesselring Site:
 - MARF/S7G is running the Developmental Materials Core (DMC).
 - S8G is in an extended refueling / overhaul outage lasting from 2015 thru 2021. Thereafter, it will be running the Technology Demonstration Core (TDC).
- Prototypes previously operated at the site were S1G, D1G and S3G. These have been permanently shut down.

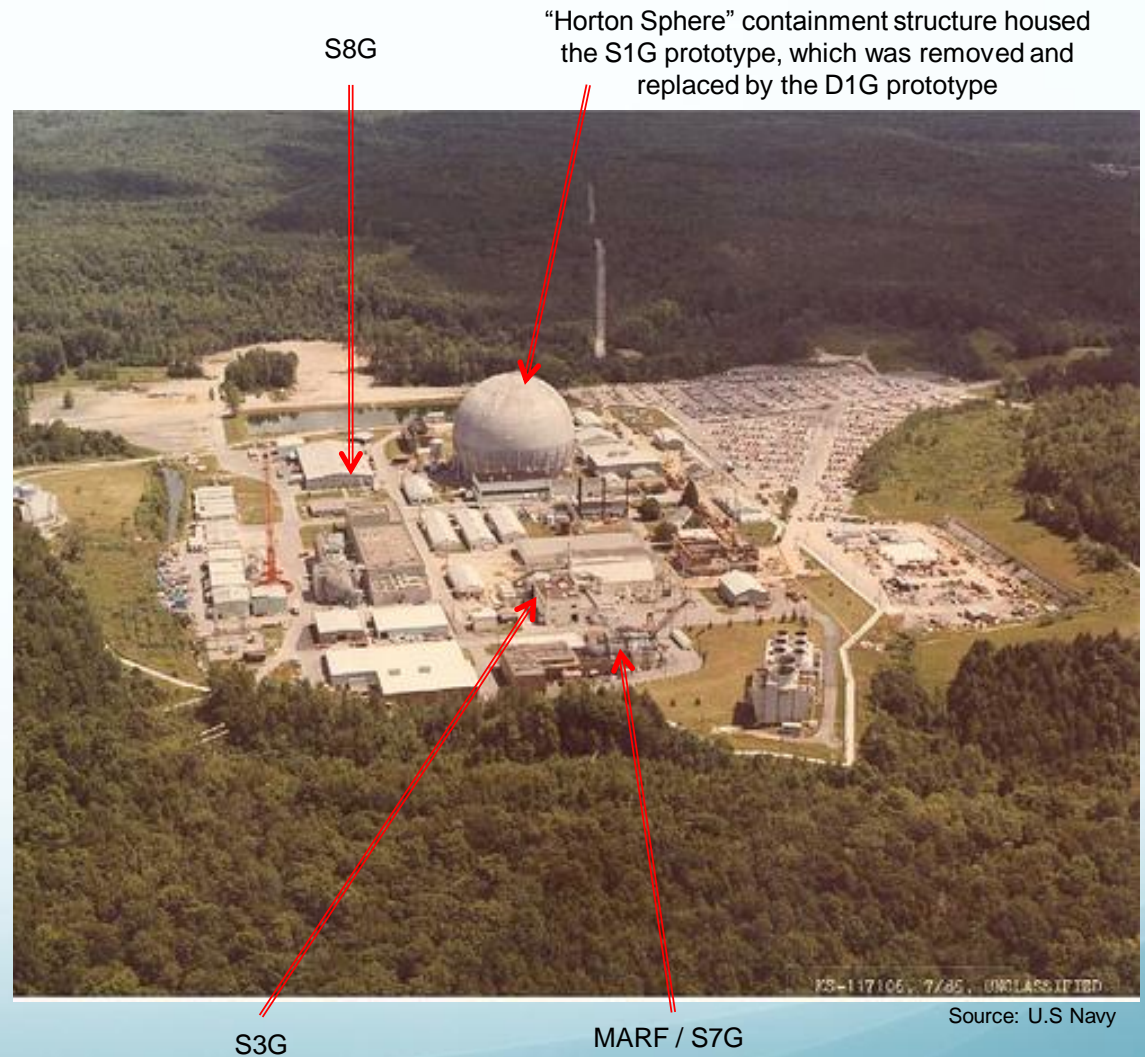

Naval Nuclear Power Training Unit (NPTU) Ballston Spa, NY.

- The two land-based naval reactor prototypes at the Kesselring Site are used for training U.S. Navy officers, enlisted personnel and contractors to safely operate naval nuclear propulsion plants.
 - MARF/S7G
 - S8G
- By 2012, KAPL has trained over 50,000 students since the beginning of the laboratory.
- Starting in FY 2018 when the S8G prototype enters an extended overhaul and refueling outage, the Naval Nuclear Power Training Program will have only three operational reactor training platforms.
- To maintain training program capacity at the Kesselring Site, the Engineerroom Team Trainer and other task trainers will be built at the Kesselring Site.



Source: <https://www.netc.navy.mil>

Bettis Atomic Power Laboratory

- Bettis is one of two government-owned, contractor-operated laboratories solely dedicated to naval nuclear propulsion work for Naval Reactors.
- Bettis is located near Pittsburgh, PA and has been operated by Bechtel Marine Propulsion Corp. since 2009, when Naval Reactors consolidated the management of KAPL and Bettis.
 - 1949 – 1998: Westinghouse was the founder and original operating contractor
 - 1998 – 2008: Bechtel Bettis, Inc. was the second operating contractor
- Bettis' mission is to help ensure the continued safe and reliable operation of the Navy's nuclear reactor propulsion plants and to develop new reactor plants to meet evolving defense requirements.
 - Bettis developed the original Oak Ridge National Laboratory design of the pressurized water reactor for operational naval use, and in collaboration with Argonne National Lab, developed the Submarine Thermal Reactor (STR) that was installed on *USS Nautilus* (SSN-571) and made the world's first "underway on nuclear power."
- Bettis has a specialized testing facility for full-scale steam generator testing, a control drive mechanism test facility.
- The laboratory is home to the U.S. Navy's Bettis Reactor Engineering School. This school provides a post-graduate certificate program in Nuclear Engineering (through the Naval Postgraduate School) with a focus on nuclear reactor design, construction, and operations.

Naval Reactors Facility (NRF)

- NRF is located on the Idaho National Lab (INL) and has been operated by Bechtel Marine Propulsion Corporation since 2009.
- NRF is the site of the S1W, A1W and S5G reactor prototype.
 - About 38,500 personnel were trained at NRF to operate surface ship and submarine nuclear propulsion plants.
 - All NRF prototypes have been permanently shut down.
 - S1W operated 36 years from May 1953 – Oct 1989
 - A1W operated 35 years from Sep 1959 – Jan 1994
 - S5G operated for 30 years from 1965 - March 1995
- The only remaining active facility at NRF is the Expanded Core Facility (ECF) / Dry Storage Facility, which provides for processing, examination and storage of spent fuel from U.S. naval reactors
 - A “recapitalization” project is underway to modernize the 50-year old ECF and give it the capability to handle the longer fuel elements from aircraft carrier reactors.
 - The 1995 “Idaho Settlement Agreement” requires that all naval spent nuclear fuel be in dry storage by 2023 and removed from Idaho by 2035.

Expended Core Facility (ECF)

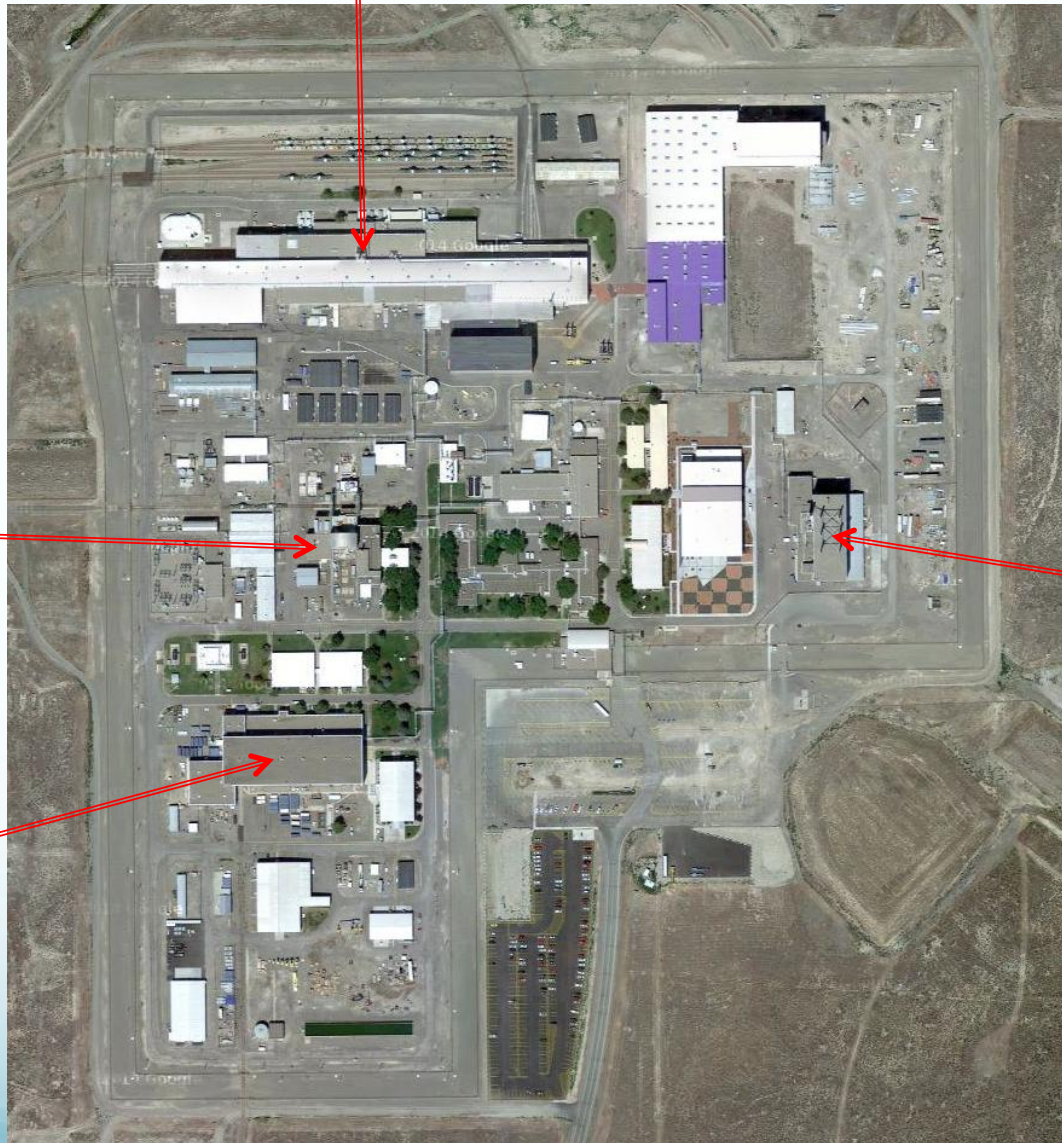

Naval Reactors Facility (NRF)

A1W

S1W

S5G



Nuclear Power Training Unit (NPTU) Goose Creek, SC

- Two decommissioned nuclear submarines are moored dockside and used as training platforms with fully-operational nuclear propulsion plants.
- Modifications made for the training role include:
 - Special mooring arrangements, with a mechanism to absorb power generated by the main propulsion shaft.
 - Removal of missile compartment from SSBNs.
 - Addition of a new hull section containing training spaces, offices, and a new reactor emergency safety system.



Moored Training Ship (MTS)	Reactor	Years delivered	Years in service
Daniel Webster (former SSBN 626) - moored training ship MTS-626	S5W	Aug 1990	1990 – present (expected thru Nov 2022)
Sam Rayburn (former SSBN-635) – moored training ship MTS-635	S5W	Jul 1989	1989 – present (expected thru May 2019)
La Jolla (former SSN-701)	S6G	Currently being converted	Expected to replace Daniel Webster in 2018
San Francisco (former SSN-711)	S6G	Conversion planned	Expected to replace Sam Rayburn

DOE Idaho Operations Office

- This DOE Nuclear Energy (NE) Field Office oversees operation of DOE programs at the Idaho National Laboratory (INL) and coordinates NR programs at the DOE-owned Advanced Test Reactor (ATR) Complex.
- ATR is a 250 MWt PWR materials test reactor built in 1967.
 - NR is the primary customer for ATR.
 - The ATR, which offers high thermal neutron flux and large test volumes, is the primary national facility with the capability for performing material irradiation testing.
 - This facility is the NR's main source of data on the performance of reactor fuel, poison, and structural materials under irradiated conditions.
 - ATR was designated as a National Scientific User Facility in April 2007. Coordination with other users is handled by the Idaho Operations Office.
- ATR Critical Facility (ATRCF) is a “zero-power” reactor used for making physics measurements of various core configurations.

ATR

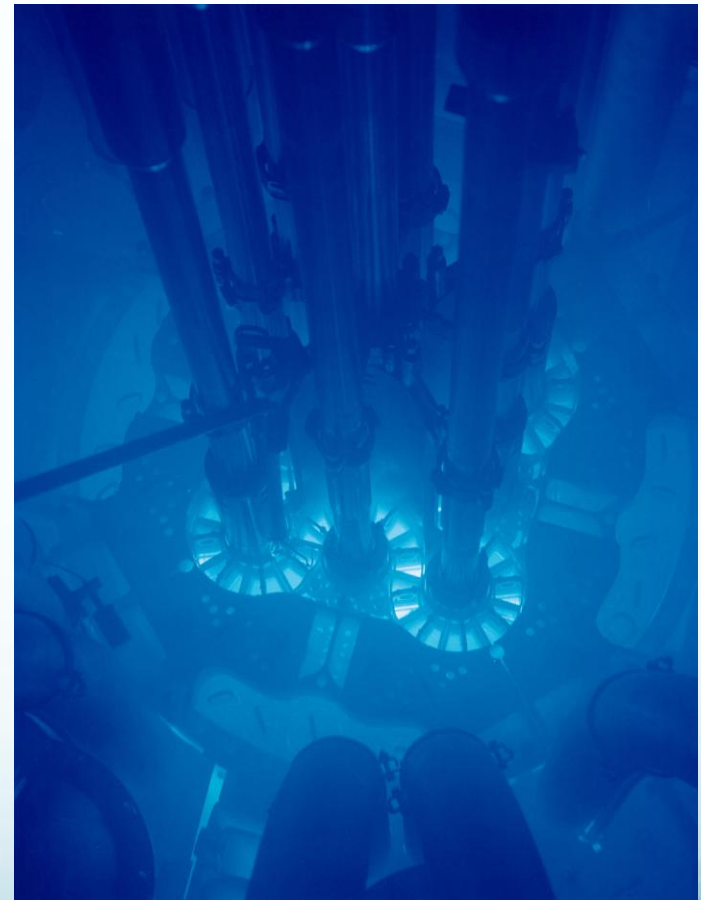

Source: Argonne National Lab

Nuclear Fuel Services (NFS)

- NFS has been the sole manufacturer of nuclear fuel for the U.S. Navy's fleet of nuclear-powered vessels since 1964.
- NFS timeline:
 - 1957: NFS established in Erwin, TN
 - 1965: Naval Fuel Production Plant constructed
 - 1996: Advanced Naval Fuel Manufacturing Facility constructed
 - 2009: B&W purchased NFS from NFS Holdings, LLC
 - 2012: NFS receives and Nuclear Regulatory Commission (NRC) operating license for an additional 25 years
 - 2014: NFS was awarded two new contracts for fuel and materials services totaling up to approximately \$302 million from the DOE, Naval Reactors Laboratory Field Office
 - Manufacture and deliver fuel and support activities for NNPP.
 - Develop materials for future Naval Reactors programs.
 - 2015: NFS was awarded \$535.1 million in contracts, primarily to manufacture fuel for Virginia-class SSNs and Ford-class aircraft carriers.



Source: <http://enformable.com>

Naval Nuclear Ship Program Management

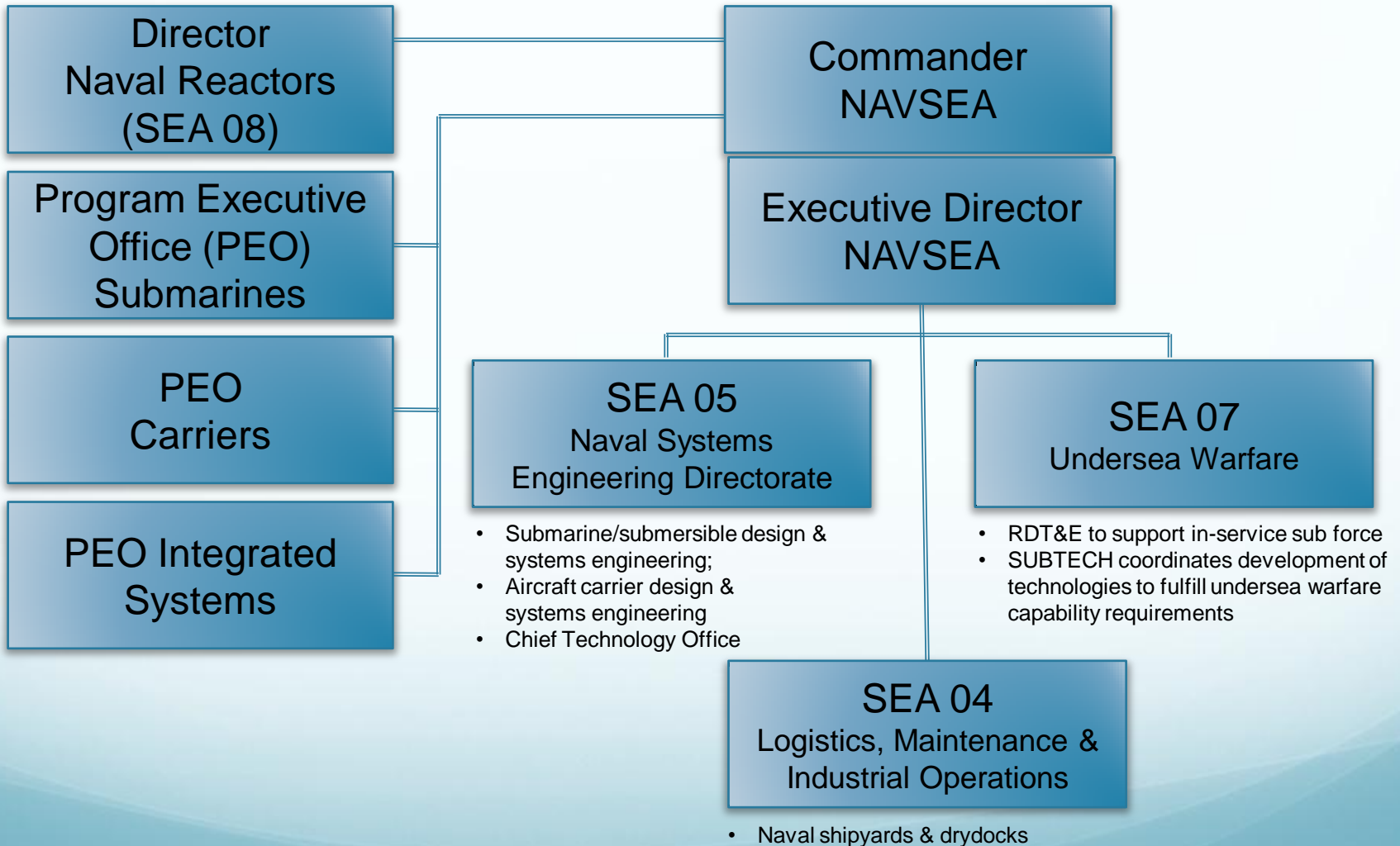

Nuclear-capable private shipyards

- Newport News Shipbuilding (a division of Huntington Ingalls Industries)
 - The sole designer and builder of aircraft carriers for the U.S. Navy.
 - Service the carriers through their lifetime, including a mid-life 4-year project that refuels the nuclear reactors
 - Teamed with Electric Boat for construction of Virginia-class SSNs
- Electric Boat (EB) Corporation (a division of General Dynamics), Quonset Point & Groton, CT
 - Prime contractor for Virginia-class SSNs
 - The EB Quonset Point automated steel processing facility manufactures submarine hull cylinders and then outfits each with tanks, propulsion and auxiliary machinery, piping, wiring, lighting, and special hull coatings.
 - These hull cylinders are transported by barge to EB Groton or Newport News Shipbuilding for completion of the submarine.
- Together, Newport News and GD/EB together have built every Navy nuclear-powered submarine procured since FY1969.

Nuclear-capable naval shipyards

- Puget Sound Naval Shipyard and Intermediate Maintenance Facility
 - Responsible for aircraft carrier and nuclear submarine intermediate maintenance
 - Sole shipyard for final disposition of nuclear vessels under the Nuclear Ship & Submarine Recycling Program (NSSRP)
- Pearl Harbor Naval Shipyard and Intermediate Maintenance Facility
 - Submarine repairs (*USS San Francisco, Hartford, Greenville, Newport News*)
- Portsmouth Naval Shipyard, Kittery, Maine
 - Submarine Maintenance Engineering, Planning and Procurement (SMEPP) Office
 - Responsible for overhaul, repair and modernization of Los Angeles-class submarines.
- Norfolk Naval Shipyard, Portsmouth, VA
 - Responsible for converting *USS La Jolla* (SSN 701) from an operational SSN into a Moored Training Ship (MTS)

U.S. Submarine Force 2015



Submarine Force Today

AMERICA'S
NAVY

A GLOBAL FORCE FOR GOOD.™

Bangor, WA
COMSUBGRU 9
SUBDEVRON-5 (3)
SUBRON-17 (7)
SUBRON-19 (3)

San Diego, CA
SUBRON-11 (6)

Pearl Harbor, HI
COMSUBPAC
SUBRON-1 (9)
SUBRON-7 (10)

Guam
SUBRON-15
(3)

Kings Bay, GA
COMSUBGRU-10
SUBRON-16 (4)
SUBRON-20 (4)

Norfolk, VA
COMSUBFOR
SUBRON-6 (8)

Groton, CT
COMSUBGRU-2
SUBDEVRON-12 (8)
SUBRON-4 (7)



FORCE STRUCTURE

43 – Los Angeles Class SSNs
3 – Seawolf Class SSNs
11 – Virginia Class SSNs
4 – Ohio Class SSGNs
14 – Ohio Class SSBNs

SUBFOR Manpower

Total: 22,910
Officer: 2,201 A + 489 R
Enlisted: 16,914 A + 1,075 R
Civilian: 1,720
Contractor: 511

Submarine Base San Diego

Ballast Point, circa early 1970s



Source: <http://www.navsource.org/>

NNPP safety performance

- 28 October 2014, Forbes article, “America's Navy - The Unsung Heroes Of Nuclear Energy,” by James Conca reported:
 - The Nuclear Navy has logged over 5,400 reactor-years of accident-free operations and travelled over 130 million miles on nuclear energy, enough to circle the earth 3,200 times.
 - U.S. Navy nuclear ships steam about two million miles per year.
 - Annual radiation doses to Navy personnel have averaged only 0.005 rem/year (5 mrem/year; 0.05 mSv/year), a thousand times less than the Federal 5 rem/year maximum allowed for radworkers.

NNPP safety performance

- May 2014, Office of Naval Reactors Report NT-14-3, “Occupational Radiation Exposure from Naval Reactors Department of Energy Facilities,” reported:
 - Total radiation exposure of all monitored staff in 2013 was 33 rem; average annual exposure was 0.006 rem per person.
 - According to the standard methods for estimating risk, the lifetime risk to the group of personnel occupationally exposed to radiation associated with the Naval Reactors Program is less than the risk these same personnel have from exposure to natural background radiation.
 - DOE requires appointing an Accident Investigation Board (AIB) for a radiation exposure occurrence that causes an individual's external radiation exposure to equal or exceed 10 rem.
 - Since the beginning of operations at NR's DOE facilities, there has never been a single radiation incident that met the criteria requiring appointment of an AIB.

U.S. naval reactors and reactor prototype facilities

Naval Reactors use of highly-enriched uranium (HEU) fuel

- HEU fuel enables high power density, long-lived reactor cores
 - More compact naval reactor plants
 - Long life and “life of the ship” cores minimize the need for costly refueling
- U.S. has a large inventory of HEU reserved for Naval Reactors use.
- 60 year track record of safe naval reactor operation with HEU-fueled reactors.
- Latest generation of submarines and surface ships already have been designed with long-life HEU reactor cores:
 - Virginia-class SSNs and Ohio-replacement SSBNs have been designed with “life of the ship” cores and will be in service for 30 – 35 years.
 - Nimitz- and Ford-class aircraft carriers have been designed for only one mid-life refueling in a 49 year service life.

Issues related to converting naval reactors from HEU to LEU fuel

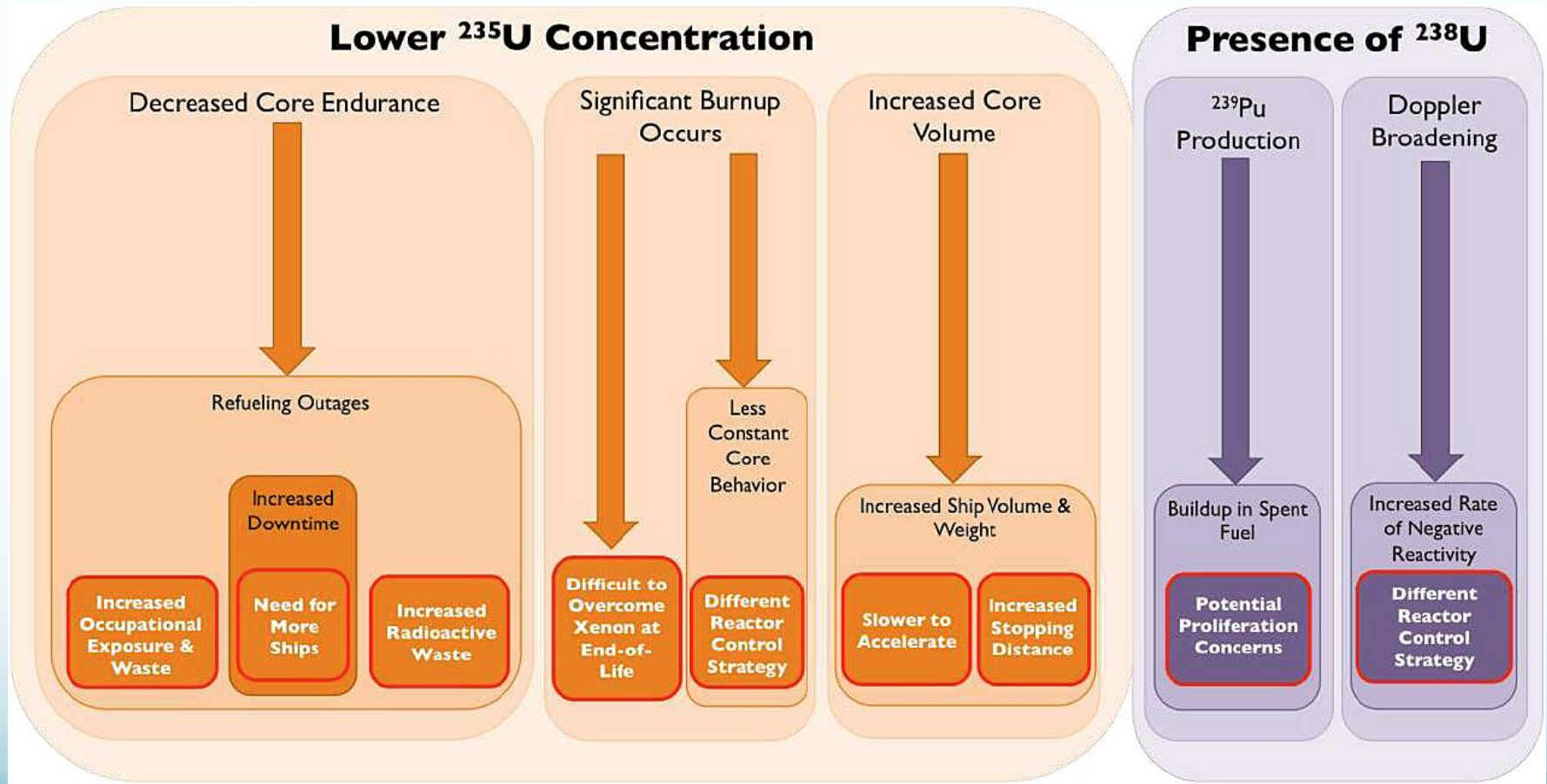

Source: *Investigation into the Unintended Consequences of Converting the U.S. Nuclear Naval Fleet from HEU to LEU*, Virginia Tech Nuclear Science and Engineering Lab (NSEL) at Arlington, 2014

Naval Reactors studies of changing from HEU to LEU fuel

- At the request of Congress, the Office of Naval Reactors issued reports in 1995 and 2014 on the potential to convert U.S. naval nuclear vessels to use LEU fuel in place of HEU fuel. Basic findings were:
 - Conversion is “technically feasible, but uneconomic and impractical.”
 - LEU as a fuel “offers no technical advantage to the Navy, provides no significant non-proliferation advantage, and is detrimental from environmental and cost perspectives.”
- In their 2014 report, NR noted that, “the potential exists to develop an advanced fuel system that could increase uranium loading,” so that LEU fuel could meet the Navy’s needs. NR also noted that, “it is not practical ... to work on an advanced fuel system without additional sources of funding.” Finally, NR noted that, “...success is not ensured.”
 - Research and development was estimated to require up to 15 years and \$2 billion.

U.S. reactor designation scheme

- Each naval reactor type is identified with a three character designator: X#X (i.e., S3G, A1W)
- 1st character is a letter that identifies the naval platform intended to use the reactor:
 - S = Submarine
 - A = Aircraft carrier
 - C = Cruiser
 - D = Destroyer-Leader class ship (all DLGNs were re-classified as cruisers, CGNs)
- 2nd character is a number that identifies the reactor design in the sequence of designs from a particular manufacturer
 - Some reactors prototypes and their corresponding fleet reactors often were given different number designations. For example, S1W was the prototype and S2W was the reactor used on a sub.
- 3rd character is a letter that identifies the reactor manufacturer
 - W = Westinghouse
 - G = General Electric
 - C = Combustion Engineering
 - B = Bechtel Marine Propulsion Corp.

U.S. Submarine Reactors

Reactor	Power (MWt)	Initial ops	Application
S1W, S2W, S2Wa	70	1953	S1W prototype, USS Nautilus (SSN-571), USS Seawolf (SSN-575) replacement powerplant
S3W, S4W	38	1957	USS Halibut (SSGN-587) and all Skate-class SSNs
S5W	78	1958	Used on 98 U.S. nuclear subs of 8 classes and on the first UK nuclear sub, HMS Dreadnought, making it the most used Navy reactor design to date. Most S5W refueled with S3G core 3.
S6W	270 (est)	1994	Core tested in S8G, used on all SSN-21 Seawolf-class subs
S1C, S2C	13 (est)	1959	S1C prototype, USS Tullibee (SSN-598)
S1G, S2G	78	1955	S1G prototype, USS Seawolf (SSN-575) original sodium-cooled reactor plant
S3G, S4G	78	1958	S3G prototype, USS Triton (SSN-586), S3G core 3 refueled many S5W plants
S5G	90	1965	S5G natural circulation prototype, USS Narwhal (SSN-671)
S6G	150 or 165	1976	Los Angeles Flight I boats has S6G with 150 MWt D1G-2 cores. All later Los Angeles-class and refueled Flight I boats got the 165 MWt D2W core
S7G / MARF	Not known	1997	MARF prototype
S8G	312 (est)	1980	All Ohio-class SSBNs and SSGNs
S9G	210	2004	All Virginia-class SSNs

Westinghouse S1W, S2W, S2Wa

Submarine Thermal Reactor (STR)

- Bettis developed the original Oak Ridge National Laboratory design of the pressurized water reactor for operational naval use, and in collaboration with Argonne National Lab, developed the Submarine Thermal Reactor (STR)
 - Fuel elements were clad in an alloy of Zirconium.
 - Reactor physics measurements were made in Argonne National Lab's Zero Power Reactor 1 (ZPR-1), which was built in 1950.
- The Navy ordered three S1W/S2W two-loop PWRs from Westinghouse.
- The first reactor became the land-based prototype, initially named STR Mark I and then S1W, built at the Naval Reactor Facility (NRF) at National Reactor Testing Station (NRTS), Idaho (later Idaho National Laboratory, INL)
 - April 1948: A formal project for the submarine reactor was established at Argonne National Laboratory
 - June 1948: Original Navy - Westinghouse contract
 - December 1948: Original Atomic Energy Commission – Westinghouse contract
 - August 1950: Start of STR Mark I construction at the NRTS, Idaho
 - 30 March 1953: STR Mark I initial criticality
 - May 1953: Power operations began, including a 96-hour high-power run to simulate a submerged transit across the Atlantic
 - 1955: The second S1W core simulated a 66-day continuous full-power run, equivalent to steaming twice around the globe

Westinghouse S1W prototype

The prototype reactor and propulsion plant were built inside a steel cylinder simulating a submarine hull. A single propeller was simulated using a water brake. Large, exterior water spray ponds dissipated heat from reactor operation.

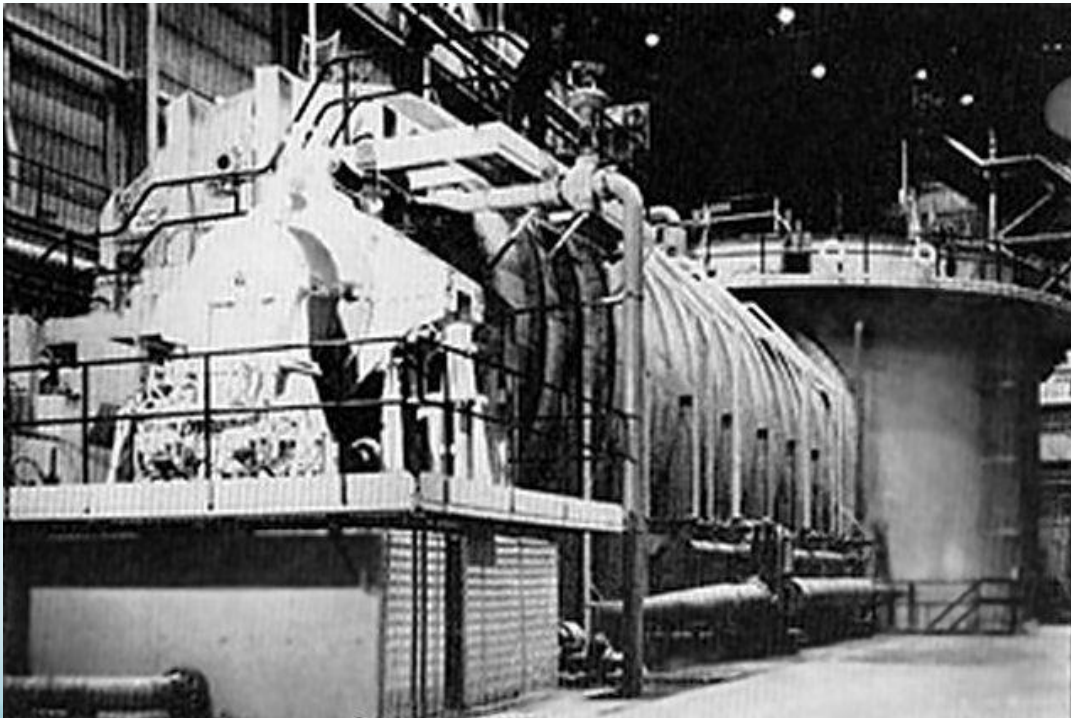

Source, 2 photos: Westinghouse

Propulsion machinery section with the shield water tank in the background

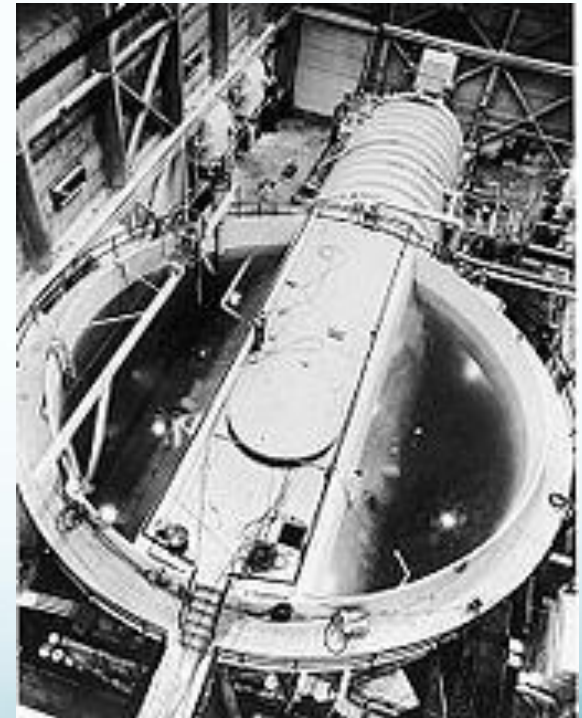

Overhead view of the shield water tank surrounding the reactor compartment

Westinghouse S1W prototype

- The S1W prototype was modified to enable testing the S5W core
 - Mid-1960s, the S1W core was removed and the prototype was modified to test an S5W reactor core.
 - The reactor vessel was extended to fit the larger S5W reactor core.
 - Steam dumps were added to dump the excess steam generated when the plant was operated at higher power levels.
 - Summer 1967: Initial criticality of the new S5W core.
 - After modifications, the prototype was called S1W/S5W core 4.
- Summer 1967: 17 Oct 1989: The S1W prototype facility was shut down permanently in 1989.
 - About 12,500 students were trained at S1W in 36 years.

Westinghouse S2W & S2Wa

- The second reactor, initially named STR Mark II and then S2W, was installed in *USS Nautilus* (SSN-671) and became the reactor that made the world's 1st "underway on nuclear power."
 - The propulsion system consisted of 1 x S2W Westinghouse PWR rated @ 70 MWt (est); 2 x main steam turbines delivering a total of 13,400 shp (10 MW) to 2 x screws
 - 1st refueling was Feb – Apr 57. Core life was about 2 years; ship traveled 62,000 miles
- The "spare" (third) S2W nuclear plant was installed on *USS Seawolf* (SSN-575) in 1958 after removal of its original S2G liquid metal-cooled core and conversion of its secondary propulsion plant to operate with saturated steam.

Westinghouse S3W, S4W

Submarine Fleet Reactor (SFR)

- This reactor was a scaled-down version of *USS Nautilus'* S2W reactor with about half the power output.
 - Unfortunately, scaling down the reactor did not reduce the weight of reactor shielding proportionally, and it was eventually realized that further downsizing was impractical
- Applications:
 - There was no S3W / S4W prototype
 - S3W was installed on *USS Halibut* (SSGN-587) and two of the Skate-class SSNs: *USS Skate* (SSN-578) and *USS Sargo* (SSN-583)
 - S4W was a modified version of S3W with horizontal steam generators as in S1W & S2W. S4W was installed on the other two Skate-class boats; *USS Swordfish* (SSN-579) and *USS Swordfish* (SSN-584)
 - The propulsion plant consisted 1 x S3W or S4W Westinghouse PWR rated @ 38 MWt (est); 2 x main steam turbines delivering a total of 7,300 hp (5.4 MW) to 2 x screw
 - Initial core lifetime was about 2,000 equivalent full power hours, increasing to 2,500 EFPH in later cores.

Westinghouse S5W

Advanced Submarine Fleet Reactor (ASFR)

- The S5W was a two-loop PWR rated at 78 MWt, with two vertical U-tube steam generators
- The reactor compartment weighted about 650 tons.
- Reactor core life improved significantly.
 - The early S5W reactor on the HMS Dreadnought was reported to have a core life of about 5,500 equivalent full power hours
 - Later S5W cores had increased life; about 10,000 EFPH.
 - The S5W plants often were refueled with the S3G core 3, with the same 78 MWt power rating and a core life of about 18,000 EFPH
- The propulsion plant consisted of 1 x S5W reactor rated @ 78 MWt; 2 x main steam turbines delivering a combined 15,000 shaft horsepower (11.19 MW) to a single propeller.
- Applications:
 - There was no separate S5W prototype.
 - The S5W was used on 98 U.S. nuclear submarines of 8 classes and on the first British nuclear submarine, *HMS Dreadnought*, making it the most used Navy reactor design to date.
 - First use of S5W reactor was on *USS Skipjack* (SSN-585) launched in May 1958.
 - As of 2015, two S5W reactor plants remain in service on moored training ships; ex-*USS Daniel Webster* (MTS-626) and ex-*USS Sam Rayburn* (MTS-635)

Westinghouse S6W

Advanced Fleet Reactor (AFR)

- S6W is large reactor plant designed to fit in the 40 ft (12.2 m) diameter hull of a Seawolf (SSN-21)-class sub.
- Like the S8G reactor plant in Ohio-class SSBNs, S6W is believed to be designed for natural circulation core cooling and is capable of operating at a significant fraction of full power without reactor coolant pumps.
- Applications:
 - There was no separate S6G prototype. The original S8G core in the S8G prototype was replaced with an S6W core.
 - Initial criticality with the S6G core occurred in March 1994
 - S8G operation with the S6G core continued until 2014.
 - The three Seawolf-class SSNs are the only subs using S6W.
 - The 1st core was loaded on *USS Seawolf* (SSN-21) in March 1995
 - The propulsion plant consists of 1 x S6W reactor rated @ 270 MWt (est); 2 x steam turbines delivering a combined 52,000 shaft horsepower (38.8 MW) to a single pump-jet propulsor.

Combustion-Engineering S1C, S2C

Submarine Reactor, Small (SRS)

- This small C-E 2-loop PWR plant had the same general layout as a Westinghouse S5W plant.
- The unique secondary system delivered propulsion power via turbine generators that drove an electric motor that was directly coupled to the main shaft and propeller.
 - No main turbines or reduction gear
 - Designed to be quieter than other contemporary nuclear propulsion systems
- Applications:
 - S1C prototype was located in Windsor, CT
 - The S1C prototype operated from 1959 until 1993. During that time, over 14,000 operators were trained there.
 - The site has been permanently closed and environmental remediation was completed in 2006.
 - S2C reactor was installed on the *USS Tullibee* (SSN-598)
 - The propulsion system consisted of 1 x S2C PWR rated @ 13 MWt (est); 2 x steam turbine generators delivering a combined 1.86 MW (2,500 shaft horsepower) to the electric drive for a single propeller.

The S1C prototype site, Windsor, CT



Source: <https://en.wikipedia.org>

General Electric S1G, S2G

Submarine Intermediate Reactor (SIR)

- This was the first liquid metal (sodium) cooled reactor developed for use on a submarine.
- The design promised a more compact reactor with greater thermal efficiency and higher power density than the Nautilus' PWR, while delivering superheated steam to drive the turbines.
- Fuel was UO_2 clad in stainless steel, with beryllium as a moderator and reflector
 - Fuel enrichment was 90%
 - The 1st core was designed for an operating life of 900 equivalent full power hours
- Sodium coolant was circulated by electromagnetic (EM) pumps, with flow regulated by changing voltage.
- Steam generator tubes, including superheater tubes, were double-walled.
 - Primary sodium coolant flowed inside the tubes
 - Secondary water / steam flowed outside the tubes
 - The space between the tube double walls was filled potassium-sodium alloy to transfer heat from the primary to the secondary system and provide a barrier against direct sodium-water contact

General Electric S1G, S2G

Submarine Intermediate Reactor (SIR)

- Applications:
 - The S2G prototype (SIR Mark A) was constructed in the “Horton Sphere” steel containment building at the Kesselring Site in West Milton, NU (now Balston Spa NPTU).
 - 20 Mar 1955: initial criticality
 - 18 May 1955: the plant generated useful power
 - The USS Seawolf (SSN-575) was the only submarine to operate with the S2G (SIR Mark B)
 - The propulsion system consisted of 1 x S2G sodium-cooled Submarine Intermediate Reactor (SIR, Mark B) rated @ 78 MWt (est); 2 x steam turbine generators delivering a combined 15,000 hp (11 MW) to 2 x screws
 - Initial sea trials were conducted in February 1957
 - The S2G core was replaced in 1958 with the “spare” Nautilus core, S2Wa, and the propulsion plant was modified and the turbine blades replaced to operate on saturated steam.
 - The removed S2G core was sealed inside a steel containment vessel, towed out to sea on a barge, then sunk about 120 miles east of Maryland. The Navy has not been able to relocate the container.

General Electric S1G prototype

(and later the D1G prototype)

“Horton Sphere” containment structure

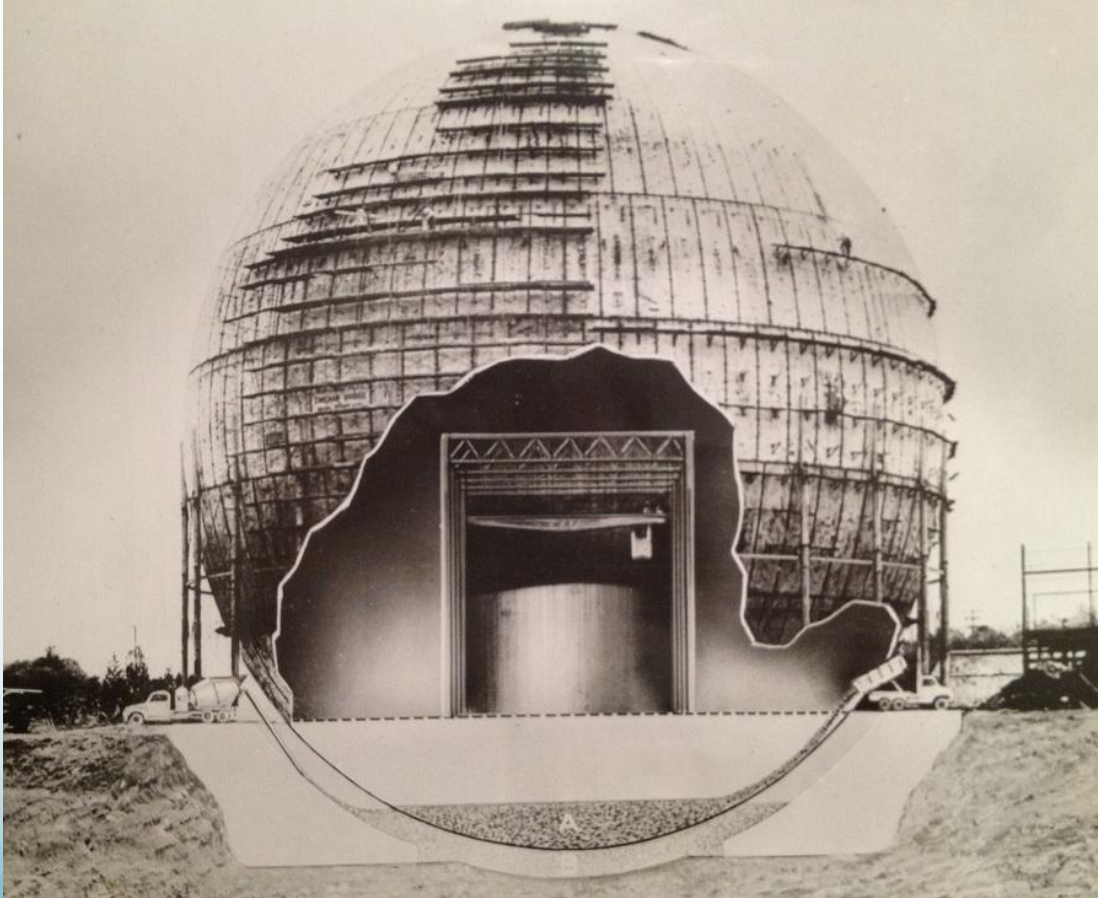

Hull and shield tank for the S1G prototype



Source, diagram + photo: atomicpowerreview.blogspot.com

General Electric S3G, S4G

Submarine Advanced Reactor (SAR)

- The S3G plant was a two-loop PWR with horizontal steam generator.
- Applications:
 - The S3G (SAR-1) prototype was built at the Kesselring Site in West Milton, NY (Ballston Spa NPTU)
 - The prototype started operation in 1958.
 - This prototype was permanently shut down in 1992 and subsequently decommissioned.
 - S3G core 3 was a very successful design, being used as the replacement core when S5W plants were refueled.
 - The core incorporated a unique “skew-divergent” design in which the fuel element arrangement looked like a bunch of pencils that were held at the middle and twisted to flare out the top and bottom of the bunch.
 - This arrangement gave more space in the reactor head area for maintenance
 - Another unique feature of the S3G core 3 was the use of "Y" shaped control rods versus the standard cruciform control rods used in the S5W reactor.
 - S3G core 3 had an operating life of about 18,000 equivalent full power hours.
 - S4G was used operationally only on the *USS Triton* (SSN-586)
 - Triton is the only U.S. submarine to have two reactors.
 - The propulsion plant consisted of 2 x S4G (SAR-2) General Electric PWRs rated @ 78 MWt, arranged fore-and-aft in the hull; 2 x steam turbines rated @ a combined 34,000 shp (est), driving 2 x shafts.

General Electric S5G

- The S5G reactor plant was designed for natural circulation core cooling and was capable of operating at a significant fraction of full power without reactor coolant pumps. It was the precursor of the S8G reactor used on Ohio-class SSBNs and SSGN-conversions.
- Applications:
 - The S5G prototype was built at the NRF at INL.
 - The prototype floated in a large pool of water and rotated about the long axis of the hull to simulate the motion of a submarine at sea making a hard turn.
 - Two-loop PWR optimized for natural circulation: larger-diameter primary system piping and steam generators located higher than in S5W plants
 - The S5G had primary coolant pumps, but they were only needed when operating at high power. These smaller single-speed pumps were either ON or OFF.
 - The S5G prototype started operation in 1965. It was permanently shut down in May 1995. About 11,500 students were trained at S5G in 30 years.
 - S5G was used operationally only on the *USS Narwhal* (SSN-671)
 - The propulsion system consisted of 1 x S5G reactor rated at 90 MWt; secondary system supplying steam to one large-diameter, directly-coupled main turbine (no reduction gear), driving a single shaft
 - Reactor core life was 10,000 equivalent full power hours
 - The single main turbine measured 12 feet in diameter, and about 30 feet long.
 - This powerplant required a larger submarine hull diameter than the previous Sturgeon-class with an S5W reactor plant (33 ft. vs. 31.6 ft.)

General Electric S5G prototype



Source: <https://en.wikipedia.org>



Source: INEL

General Electric S6G

- The S6G submarine reactor plant originally was designed to use the 150 MWt D1G-2 core, similar to the 148 MWt D2G reactor used on guided missile cruisers (CGNs).
- Applications:
 - There was no separate S6G prototype. The D1G-2 core had been tested previously in the D1G prototype at the Kesselring Site in West Milton, NY.
 - Starting in the mid-1970s, the S6G with D1G-2 core was installed on all Los Angeles-class Flight I subs.
 - 1 x S6G reactor plant with a D1G-2 reactor core rated @ 150 MWt; 2 x main steam turbines delivering a combined 30,000 shp (est) to a single propeller.
 - The D1G-2 cores in 17 688 Flight I boats were replaced with D2W cores during their mid-life refueling
 - The mid-life refuelings for the remaining 14 Flight I boats were cancelled and the boats were decommissioned early.
 - Starting in the mid-1980s, all Los Angeles-class Flight II and Improved (688i) submarines, starting with USS Providence (SSN-719), were built with a newer D2W core rated at 165 MW.
 - 1 x S6G reactor plant with a D2W reactor core rated @ 165 MWt; 2 x main steam turbines delivering a combined 33,500 shp (est) to a single propeller.
 - All Flight II and 688i boats require a mid-life refueling.
 - The reactor compartment measured 33 ft in diameter, 42 ft long, and weighted 1,680 tons

General Electric S7G

Modifications and Additions Reactor Facility (MARF)

- The MARF reactor had a “rod-less” core that lacked conventional control rods.
- Instead of using moveable hafnium control rods, as used in all other Navy reactors, reactivity in the S7G core was controlled by stationary gadolinium-clad tubes partially filled with water.
 - Gadolinium has a high cross-section for thermal neutrons and a lower cross-section for higher-energy neutrons.
 - Neutrons passing through the section of the gadolinium tube with water were likely to be thermalized inside the tube and captured by the gadolinium on their way out of the tube.
 - Neutrons passing through the section of the gadolinium tube without water were much less likely to be thermalized inside the tube and more likely to simply pass through the tube and re-enter the reactor core.

General Electric S7G

Modifications and Additions Reactor Facility (MARF)

- The reactivity control system controlled reactor power by regulating the water levels inside the gadolinium tubes.
 - The control system pumped water from inside the gadolinium tubes to a reservoir above the core, or allowed water to flow back from the reservoir into the tubes.
 - During reactor startup, water level in the tubes was gradually lowered, decreasing the neutron absorption by the gadolinium tubes and permitting the reactor to enter the power range
 - The gadolinium tubes provide a desirable negative reactivity feedback. For example, an increase in reactor power causes all the water in the reactor to expand, including the water in the gadolinium tubes. As water level in the tubes rises, more neutrons are thermalized and absorbed in the gadolinium, thereby limiting the power increase.
 - The pumping system was configured so that the pump needed to run continuously to keep the level pumped down. On loss of power, all the water in the reservoir would flow back into the tubes, shutting down the reactor.
- Applications:
 - The S7G prototype reactor core was installed adjacent to the S3G prototype in West Milton, NY (Ballston Spa NPTU).
 - MARF began operation in 1976
 - In the late 1980s, the original MARF core was removed and replaced by the Developmental Materials Core (DMC)
 - The S7G reactor core was not used on any operational submarine.

General Electric S8G

- The S8G reactor plant was designed for natural circulation core cooling and is capable of operating at a significant fraction of full power without reactor coolant pumps. S8G is a development of the S5G.
- Applications:
 - The S8G prototype was built at the Kesselring Site in West Milton, NY
 - The prototype is equipped with an automatic reactor fill system that can flood the reactor with borated water in the event of a loss of coolant accident.
 - The prototype started operation some time around 1980.
 - In 1994, the original S8G core was replaced with an S6W core to be used on the Seawolf-class SSNs
 - In 2018, the S8G prototype is scheduled to start a 3-year refueling and overhaul outage intended to support the Ohio-replacement reactor design.
 - The S6W Seawolf core will be replaced with the “Technology Demonstration Core” (TDC) and other changes will be made to update the facility.
 - S8G is used operationally on all Ohio-class SSBNs and SSGN-conversions
 - 1 x S8G PWR rated at 312 MWt (est.), 2 x main steam turbines with a combined rating of 60,000 hp (45 MW) driving a single shaft.
 - Some sources cite a reactor power rating of 220 MWt, but this seems too low to deliver the cited 60,000 shp propulsion power.
 - S8G reactor compartment for the Ohio submarines is 42 feet (13 m) in diameter, 55 feet (17 m) long and weights 2,750 tons
 - Ohio-class subs require a mid-life refueling.

General Electric S9G

- The S9G reactor plant was designed for the Virginia-class SSN, which has a 33 ft (10.1 m) diameter hull, the same as *USS Narwhal* (SSN-671) and all Los Angeles-class SSNs.
- It is believed that S9G is designed for natural circulation core cooling and is capable of operating at a significant fraction of full power without reactor coolant pumps.
- Applications:
 - There is no S9G prototype
 - S9G is used operationally on all Virginia-class SSNs. 1st-in-class *USS Virginia* (SSN-774) was commissioned in October 2004.
 - The propulsion system consists of 1 x S9G reactor rated @ 210 MWt (est); secondary steam plant delivering a combined 40,000 shaft horsepower (29.8 MW) to a single pump-jet propulsor.
 - Expected service life is 33 years without refueling

Transformational Technology Core (TTC)

- The primary design goal for the TTC is delivering 30% more lifetime energy, while still fitting in the S9G reactor vessel used in the Virginia-class submarine.
 - This core will provide greater operational flexibility by extending ship life, increasing annual operating hours, and/or allow operation at a higher average power during ship operations.
 - This will be accomplished primarily through use of advanced core material that allow safe operation at higher power density.
- The Navy has decided that future naval reactor cores will use highly-enriched uranium (HEU) uranium from retired nuclear weapons and the average uranium enrichment in naval reactor fuel will be decreased 97% to 93%.
 - This transition is necessitated by the shutdown of the U.S uranium enrichment plants that were capable of making HEU.
- TTC is scheduled to be delivered in 2015. It is unclear if TTC is the same as the Technology Demonstration Core (TDC), described in the NR 2014 Congressional Budget Request, that will be loaded in the S8G prototype reactor during its 2018 – 2021 refueling outage.
- This advanced core is intended for forward fitting into Virginia-class submarines that also have upgraded plant systems to exploit the anticipated performance improvements of the TTC.

U.S. Surface Ship Reactors

Reactor	Power (MWt)	Initial ops	Application
C1W	200	1961	2 x C1W used only on <i>USS Long Beach</i> (CGN-9)
D1G, D2G	148	1962	D1G prototype, 2 x D2G used on <i>USS Bainbridge</i> (CGN-25), <i>USS Truxtun</i> (CGN-35) and all California (CGN-36)- and Virginia (CGN-38)-class CGNs
A1W, A2W	150 (est)	1958	2 x A1W at the prototype, 8 x A2W on <i>USS Enterprise</i> (CVN-65)
A3W	300 (est)	---	4 x A3W, intended for <i>USS John F Kennedy</i> (CV-67); keel laid in 1964; design changed and completed as a conventionally-powered aircraft carrier. A3W not built.
A4W	550	1975	¼ core tested in A1W-B prototype; 2 x A4W on all Nimitz-class CVNs
A1B	550 (est)	2015	2 x A1B on all Gerald R. Ford-class CVNs

Westinghouse C1W

- This was the first nuclear reactor designed for use on a cruiser.
 - It originally was designed as a four reactor powerplant capable of producing the same propulsion power as a Des Moines-class heavy cruiser: 120,000 shp.
- Applications:
 - There was no C1W prototype
 - The only use of C1W was on the USS Long Beach (CGN-9)
 - The propulsion system consisted of 2 x C1W reactors each rated @ 200 MWt (est); 2 x steam turbines driving 2 x shafts; total propulsion power 80,000 hp (60 MW).
 - Long Beach's reactors were refueled twice. Cores 1 & 2 operated for an average of 9.5 years; Core 3 operated for almost 14 years.

General Electric D1G, D2G

- The D1G propulsion plant originally was designed for large guided missile “destroyer-leader” class ships (DLGN), which later were reclassified as guided missile cruisers (CGN).
- Applications:
 - The D1G prototype was constructed in the “Horton Sphere” steel containment building previously used for the S2G prototype reactor at the Kesselring Site in West Milton, NY (now Balston Spa NPTU)
 - 1962: operation started
 - The D1G prototype was refueled with the D1G-2 core
 - March 1996: D1G permanently shut down
 - 2002: reactor pressure vessel removed
 - The D2G was used to power *USS Bainbridge* (CGN-25), *USS Truxtun* (CGN-35), the two California (CGN-36)-class ships, and the four Virginia (CGN-38)-class ships.
 - The propulsion system consisted of 2 x D2G reactors each rated @ 148 MWt; 2 x steam turbines driving 2 x shafts; total propulsion power 60,000 hp (45 MW).
 - The D2G reactor compartment measured 31 ft in diameter x 37 ft in length; weighed 1,400 tons.
 - *USS Bainbridge* refueled three times and *USS Truxtun* refueled twice; each time with longer-life cores: 1st cores: 5 – 6.5 years; last cores: 13 years.
 - In 1993 the Navy cancelled mid-life refueling overhauls for all California- & Virginia-class CGNs.
 - The S6G reactor plant developed for the Los Angeles-class Flight I SSNs used the 150 MWt D1G-2 core, similar to the 148 MWt D2G reactor used on CGNs.

Westinghouse A1W, A2W

Large Ship Reactor (LSR)

- This was the first nuclear reactor designed for use on an aircraft carrier.
- Applications:
 - The A1W reactor prototype was built at the Naval Reactors Facility (NRF) at the Idaho National Lab (INL)
 - The prototype consists of 2 x A1W reactors (A1W-A & A1W-B) operating as a pair; with their secondary systems supplying steam to 1 x main turbine, driving a single shaft.
 - A dump condensers simulate the transient steam demand during aircraft catapult launches. This was a surplus ESSEX-class main condenser installed adjacent to A1W
 - Oct 1958: A1W 1st reactor initial criticality
 - Jul 1959: A1W 2nd reactor initial criticality
 - mid-Sep 1959: full-power operation achieved with both reactors
 - Early 1970s: A1W-B core replaced by $\frac{1}{4}$ of an S4W core destined for the Nimitz-class aircraft carriers
 - 26 Jan 1994: A1W prototype permanently shut down. About 14,500 students were trained at A1W.
 - The *USS Enterprise* (CVN-65) propulsion system consisted of 8 x A2W reactors each rated @ 150 MWt (est); supplying 4 x steam turbines driving 4 x shafts; total propulsion power 280,000 hp (210 MW).
 - The secondary system also supplied steam for catapults.
 - Cores 1 & 2 operated for an average of 3 years; Cores 3 & 4 operated for an average of 18.9 years

Westinghouse A4W

- This reactor was developed for, and is used on all 10 of the Nimitz-class aircraft carriers.
- Applications:
 - There is no separate A4W reactor prototype.
 - Early 1970s: At the A1W prototype at the Naval Reactors Facility (NRF) on Idaho National Lab (INL), the A1W-B core was replaced by $\frac{1}{4}$ of an S4W core.
 - 26 Jan 1994: A1W prototype permanently shut down
 - The Nimitz propulsion system consists of 2 x A4W reactors each rated @ 550 MWt (est); 4 x steam turbines driving 4 x shafts; total propulsion power 260,000 hp (194 MW).
 - The secondary system also supplies steam for:
 - 8 X turbine generators with a combined rating of 64 MW
 - Catapults for launching aircraft
 - The carriers are designed for an operating life of 49 years with one mid-life refueling, so average core life is about 25 years.

Bechtel A1B

- This reactor was developed for the Gerald R. Ford-class aircraft carriers.
 - The reactor power rating of the A1B is not known, but is expected to be a greater than the 550 MWt A4W.
 - The ship propulsion system is expected to be generally similar to that of the Nimitz-class carriers: 2 x large PWRs driving 4 x main steam turbines, which deliver about 260,000 shp (194 MW) propulsion power to 4 x main shafts & propellers.
 - The secondary steam system no longer supplies steam to the catapults.
 - One major change is that the reactor plants will be delivering a substantially greater electric power generating capacity to support the shift to electromagnetic catapults and arresting gear, and to power future high-energy weapons.
 - Nimitz-class CVNs have 64 MWe electric generating capacity. Ford-class CVNs are expected to have 300 MWe generating capacity.
 - In 2004, the Navy reported to Congress that:
 - “The CVNX reactor (now A1B) will provide greater than 25 percent more energy than the reactors in Nimitz-class ships.”
 - “CVNX...will require just half the number of sailors to operate and will be easier to maintain.”
- Applications:
 - There is no separate A1B reactor prototype.
 - The Ford-class carriers are designed for an operating life of 49 years and are expected to require one mid-life refueling.

U.S. Navy nuclear-powered submarines

Fast attack submarines (SSN)

U.S fast attack subs (SSN)

Class	# in Class	Length	Beam	Displacement (tons)	Reactor	Shaft hp	Max speed (kts)	Years delivered	Years in service
Nautilus (SSN-571)	1	98.4 m (323.8 ft)	8.4 m (27.7 ft)	3533 (surf) 4092 (sub)	S2W (STR Mk II)	13,400	23	Sep 1954	1955 – 80
Seawolf (SSN-575)	1	103 m (350 ft)	8.5 m (28 ft)	3250 (surf), 4150 (sub)	S2G, replaced by S2Wa	15,000, then 13,400	19	Mar 1957	1957 - 87
Skate (SSN-578) (Skate & Sargo)	2	81.6 m (267.7 ft)	7.6 m (25 ft)	2590 (surf), 2894 (sub)	S3W	7,300	22	Dec 1957 – Apr 58	1986 - 88
Skate (SSN-578) (Swordfish & Seadragon)	2	Same	Same	Same	S3W core in S4W plant	Same	Same	Sep 1958 – Dec 59	1984 - 89
Triton (SSRN/SSN-586)	1	136.4 m (447.6 ft)	11 m (37 ft)	6,058 (surf), 7,898 (sub)	2 x S4G	34,000	27+	Nov 59	1959 - 69
Tulibee (SSN-597)	1	83 m (273 ft)	7.2 m (23.6 ft)	2353 (surf), 2649 (sub)	S2C	2,500 (est.)	14.8	Nov 1960	1960 - 88
Skipjack (SSN-585)	6 (1 lost at sea)	77 m (251.7 ft)	9.6 m (31.5 ft)	3124 (surf), 3600 (sub)	S5W	15,000	33	Apr 1959 – Oct 61	1959 - 90
Permit (SSN-594)	14 (1 lost at sea)	84.9 m (278.4 ft)	9.6 m (31.6 ft)	3810 (surf), 4369 (sub)	S5W	15,000	28	Aug 1961 – Jan 68	1961 - 96
Sturgeon (SSN-637, short-hull)	28	89 m (292 ft)	9.6 m (31.6 ft)	3640 (surf), 4640 (sub)	S5W	15,000	27	Mar 1967 – Aug 75	1967 - 2005
Sturgeon (SSN-637, long-hull)	9	92 m (302 ft)	9.6 m (31.6 ft)	4530 (surf) 5040 (sub)	S5W	15,000	26	Mar 1967 – Aug 75	1967 - 2005
Narwhal (SSN-671)	1	95.7m (314 ft)	10.1 m (33 ft)	4300 (surf) (est), 5350 (sub)	S5G	17,000 (est)	25 (est)	July 1969	1969 - 99

U.S fast attack subs (SSN)

Class	# in Class	Length	Beam	Displacement (tons)	Reactor	Shaft hp	Max speed (kts)	Years delivered	Years in service
Glenard P Lipscomb (SSN-685)	1	111.3 m (365 ft)	9.6 m (31.6 ft)	5906 (surf), 6584 (sub)	S5W	15,000	23	Dec 1974	1974 - 89
George Washington – class conversion to SSN (“slow attack”)	3 Mod SSBN	16.3 m (381.6 ft)	10.1 m (33 ft)	6000 (surf), 6880 (sub)	S5W	15,000	20+	1979	1979 - 85
Los Angeles (SSN-688 Flight I)	31	110 m (362 ft)	10.1 m (33 ft)	6082 (surf), 6927 (sub)	S6G with D1G-2 core, refueled with D2W	30,000	> 30	Nov 1976 – Jul 85	1976 - present
Los Angeles (SSN-688 Flight II)	8	110 m (362 ft)	10.1 m (33 ft)	6082 (surf), 6927 (sub)	S6G with D2W core	35,000	> 30	Jul 1985 – Jun 89	1985 - present
Improved Los Angeles (688i)	23	110 m (362 ft)	10.1 m (33 ft)	6082 (surf), 6927 (sub)	S6G with D2W core	35,000	> 30	Aug 1988 – Sep 96	1988 - present
Seawolf (SSN-21)	3	107.6 m (353 ft)	12.2 m (40 ft)	7568 (surf), 9137 (sub)	S6W	52,000	> 30	Jul 1997	1997 - present
Virginia (SSN-774 Block I)	4	114.8 m (377 ft)	10.1 m (33 ft)	xxxx (surf), 7800 (sub)	S9G	40,000	25+	Oct 2004 - May 08	2004 - present
Virginia (SSN-774 Block II)	6	114.8 m (377 ft)	10.1 m (33 ft)	xxxx (surf), 7800 (sub)	S9G	40,000	25+	Oct 2008 – Sep 13	2008 - present
Virginia (SSN-774 Block III)	2 + 6 plan	114.8 m (377 ft)	10.1 m (33 ft)	xxxx (surf), >7800 (sub)	S9G	40,000	25+	Oct 2014 - 2018	2014 - present
Virginia (SSN-774 Block IV)	10 plan	114.8 m (377 ft)	10.1 m (33 ft)	xxxx (surf), >7800 (sub)	S9G	40,000	25+	1 st in 2019	
Virginia SSGN (SSN-774 Block V)	TBD	136.2 m (447 ft)	10.1 m (33 ft)	Not known	S9G	40,000	25+	After 2020	

Nautilus (571)

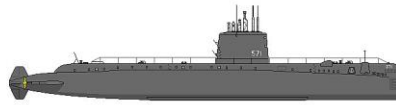

Skate (578)-class



Skipjack (585)-class



Triton (586)



Permit (594)-class



Tullibee (591)



Sturgeon (637)-class



Los Angeles (688)-class

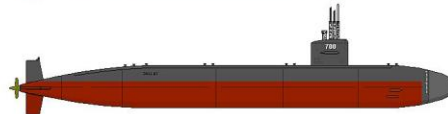

Improved Los Angeles (688i)-class

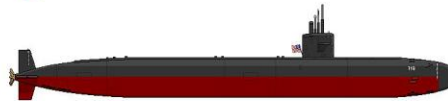

Seawolf (SSN-21)-class



Virginia (774)-class



Evolution of U.S. Navy SSNs

Submarine reactor compartments

Except for *USS Triton*, all U.S. submarines have a single reactor in a shielded reactor compartment located between the aft engineering / propulsion spaces and the forward operations / weapons / living spaces. Approximate dimensions and weights of the reactor compartment are shown in the diagrams.

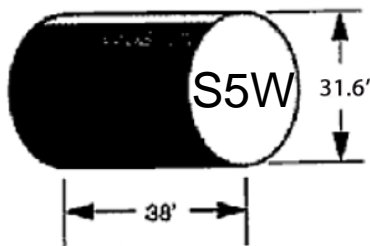
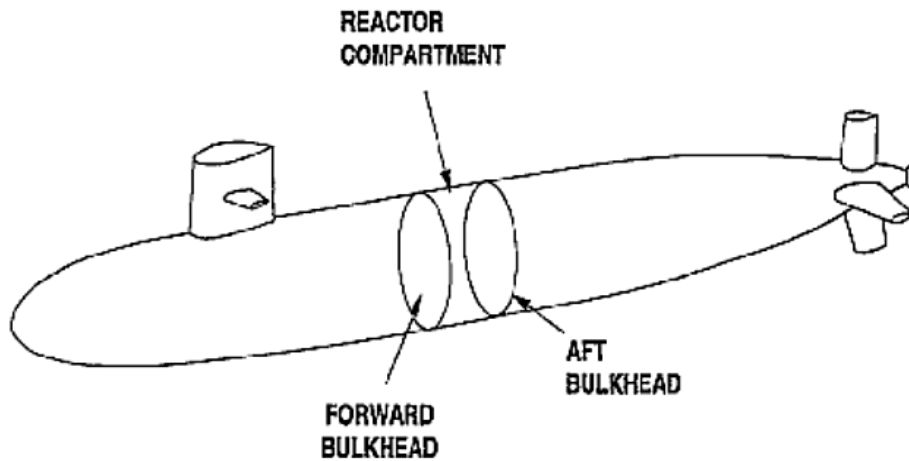

Pre LOS ANGELES
Class
Submarine - about 110
(1130 tons)

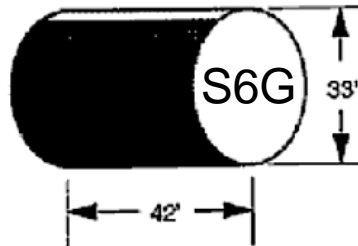

LOS ANGELES
Class
Submarine - 62
(1680 tons)

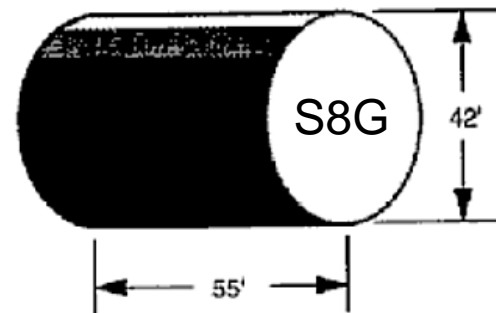

OHIO Class
Submarine - 18
(2750 tons)

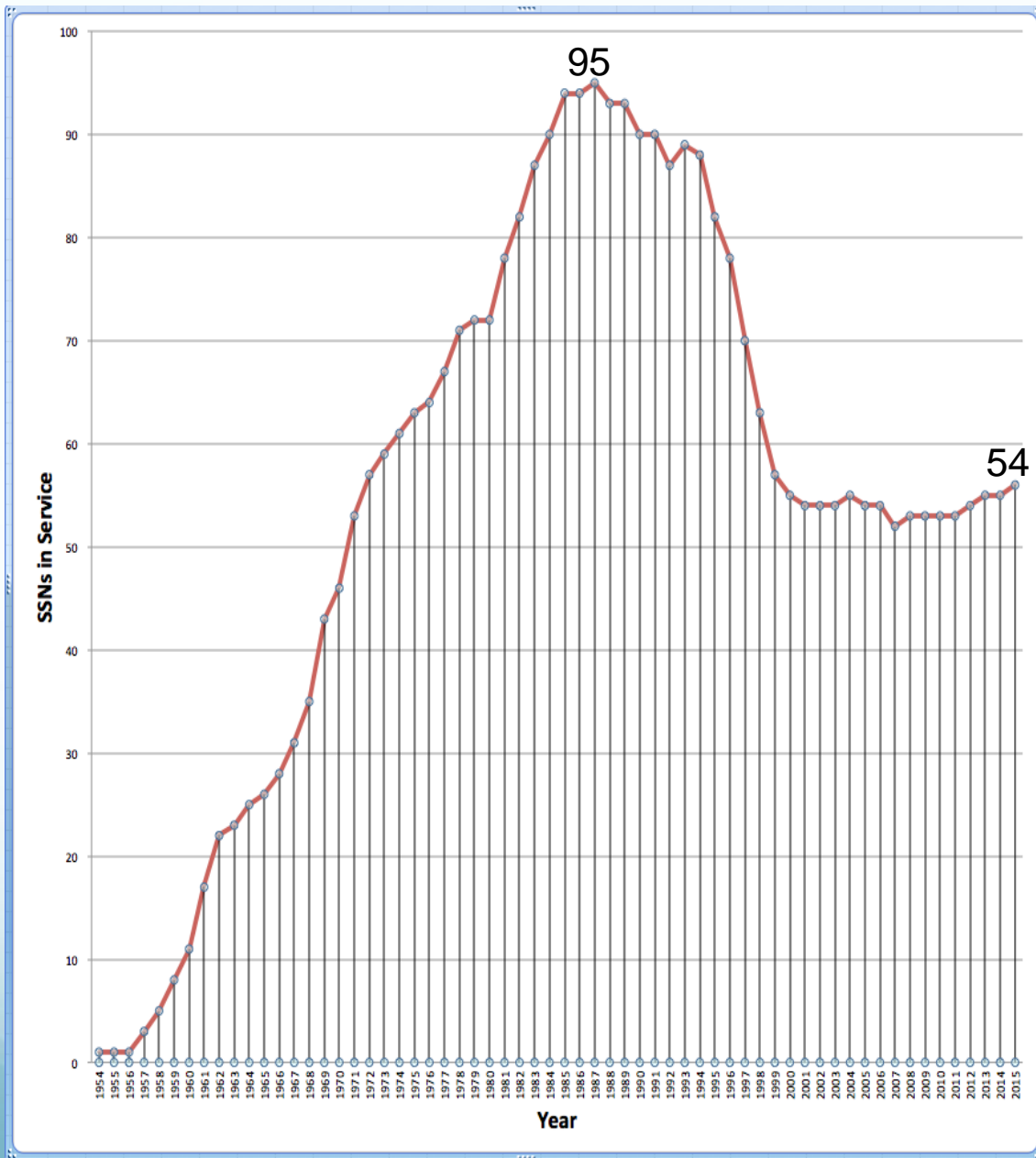

Historical
size of the
U.S. Navy's
SSN fleet

USS Nautilus (SSN-571)

World's 1st nuclear-powered vessel

Source: tuningpp.com

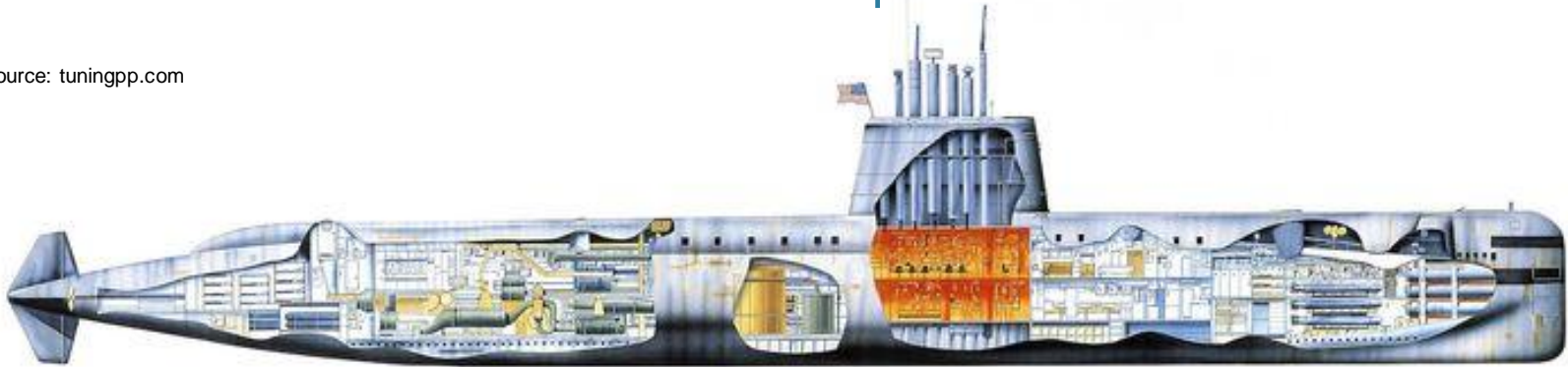

- Basic hull form was very similar to WW II German Type XXI subs and the latest U.S. diesel-electric subs [i.e., *USS Tang* (SS-563)]
- Propulsion: 1 x S2W Westinghouse PWR rated @ 70 MWt (est); 2 x main steam turbines delivering a total of 13,400 hp (10 MW) to 2 x screws
- From project approval to underway on nuclear power in 5 years:
 - Aug 1949: Chief of Naval Operations establishes a January 1955 "ready-for-sea" date for development of a submarine nuclear propulsion plant
 - Aug 1950: President Truman signs Public Law 674 authorizing construction of the 1st nuclear sub
 - July 1951: Congress funds construction
 - 14 Jun 1952: Keel laid by President Truman at Electric Boat Co, Groton, CT
 - 21 Jan 1954: Launched by First Lady Mamie Eisenhower
 - 30 Sep 1954: Commissioned, remained dockside to complete outfitting.
 - 17 Jan 1955: 1st underway on nuclear power
- Armament: 6 x 533 mm (21") bow torpedo tubes. No stern tubes.

USS Nautilus (SSN-571)

- Capt. Eugene P. Wilkinson was the first commanding officer of the *USS Nautilus*.
- The famous message, “UNDERWAY ON NUCLEAR POWER,” was sent by flashing light signal to Commander Submarine Forces Atlantic on 17 Jan 1955.
- Operational matters:
 - Capt. Wilkinson was responsible for post-commissioning trials, which provided a first look at the the greatly expanded capabilities of a nuclear-powered submarine and were used in the development of early nuclear-powered submarine tactics.
 - February 1955: *USS Nautilus* conducted a 1,381 mile (2,222 km) “shakedown cruise” from New London, CT to Puerto Rico, transiting submerged at an average speed of 16 kts. This was the 1st long-distance, high-speed transit ever made by a submarine.
 - Fall 1962: *USS Nautilus* participated in the Naval quarantine of Cuba
 - *USS Nautilus* was decommissioned on 3 March 1980 after cruising 513,000 miles (825,593 km). It opened as a museum ship in Groton, CT on 11 April 1986

U. S. NAVAL DISPATCH
MSG-GEN-1007

FROM: USS NAUTILUS SSN 571 CLASSIFICATION: UNCL PRECEDENCE: ROUTINE

ACTION: COMSUBLANT

INFO:

NJOE DE NWCL
-T-YZZF
-R-171601Z -FM NWCL -TO YZZF CR 1/ BT

UNDERWAY ~~1133R~~ ON NUCLEAR POWER BT....

700 / 1133R WU/ELT
F.L. / F.L. 1/5
PBR

NO.	1	2	3	4	5	6	7	8	9	10	11	12	13	14	15	16	17	18	19	20	21	22	23	24
DATE																								
TIME																								
CLASS																								
NO.																								

NO. 171601Z

Source: U.S. Navy



Capt. Wilkinson

Source: U.S. Navy

Operation Sunshine

1st Arctic missions to the North Pole

- *Nautilus*' 2nd CO, CDR. William R. Anderson, sailing from New London, CT on 19 Aug 1957, conducted the first extended Arctic under-ice voyage (1,202 nm) by a nuclear submarine.
- *Nautilus* departed Seattle, WA for the polar ice pack on 9 Jun 1958, but was turned back by thick ice conditions blocking all paths to the deep Arctic Ocean and the North Pole.
- After departing Pearl Harbor on 3 Aug 1958 on its third Arctic voyage, *Nautilus* encountered improved ice conditions and became the first vessel to reach the North Pole on 3 Aug 1958.

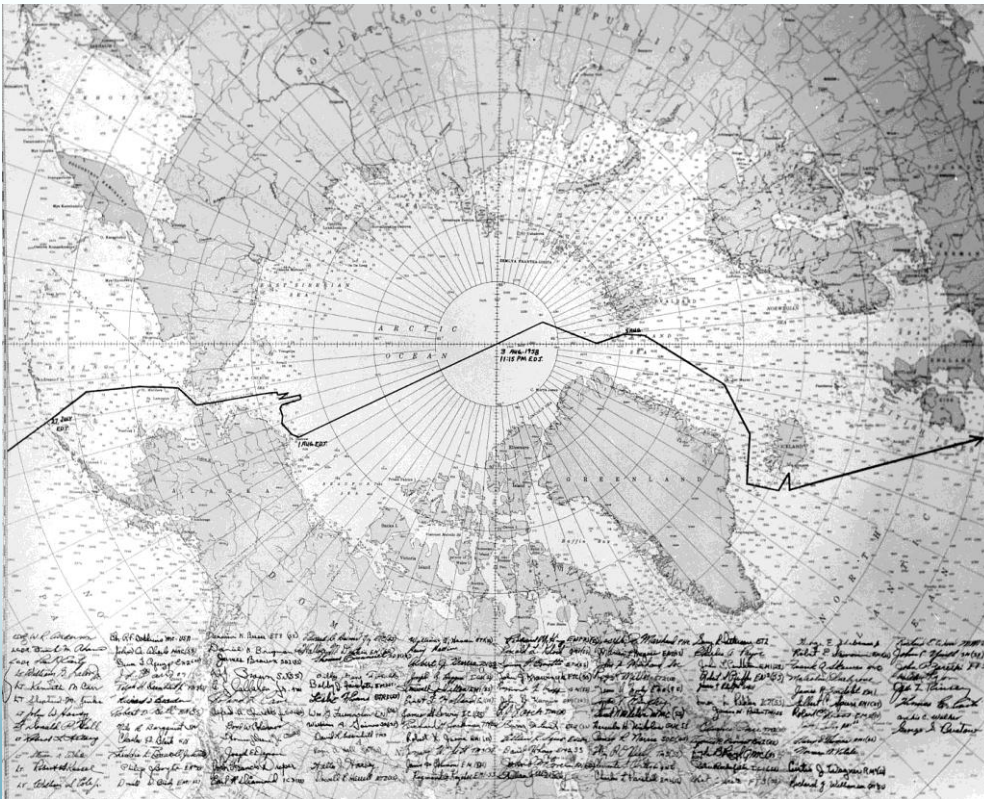

SHIP'S POSITION			
U. S. S. <u>NAUTILUS</u>			
TO: COMMANDING OFFICER			
TIME OF DAY	DATE		
<u>1915U</u>	<u>3 August 1958</u>		
LATITUDE	LONGITUDE		
<u>90° 00.0' N</u>	<u>Indefinite</u>		
BY (Indicate by check in box)			
<input checked="" type="checkbox"/> <u>N6A</u>	<input checked="" type="checkbox"/> <u>MK19</u>	<input type="checkbox"/> <u>BRDR</u>	<input type="checkbox"/> <u>VISION</u>
SET	DRIFT	DISTANCE MADE GOOD SINCE (TIME) (MILES)	
<u>—</u>	<u>—</u>	<u>Honolulu 4844</u>	
DISTANCE TO		MILES	BEARING
<u>North Pole</u>		<u>Zero</u>	<u>—</u>
TRUE HOG. ERROR	ORIENTATION		
<u>180 MK19</u>	<u>3E MK19</u>	<u>0°</u>	<u>170° E</u>
MAGNETIC COMPASS (OF ALL TYPES) (MARK)			
<input type="checkbox"/> <u>STD</u>	<input type="checkbox"/> <u>LEAK</u>	<input checked="" type="checkbox"/> <u>IND</u>	<input type="checkbox"/> <u>OTHER</u>
DEVIATION		TO (Indicate by check in box)	
<u>126E</u>	<u>3° W</u>	<input type="checkbox"/> <u>ON</u>	<input checked="" type="checkbox"/> <u>OFF</u>
REMARKS			
<u>NGADR</u>		<u>NGA</u>	
<u>σ = 0</u>		<u>σ₁ = 0</u>	
<u>μ = 0</u>		<u>σ₂ = 0</u>	
		<u>σ₃ = 1°</u>	
RESPECTFULLY SUBMITTED			
<u>LT Charles M. Gember, USN</u>			

Source: <http://www.navalhistory.org/category/arctic>

Source: <http://www.navy.mil/navydata/>

USS Seawolf (SSN-575)

first submarine with a sodium-cooled reactor

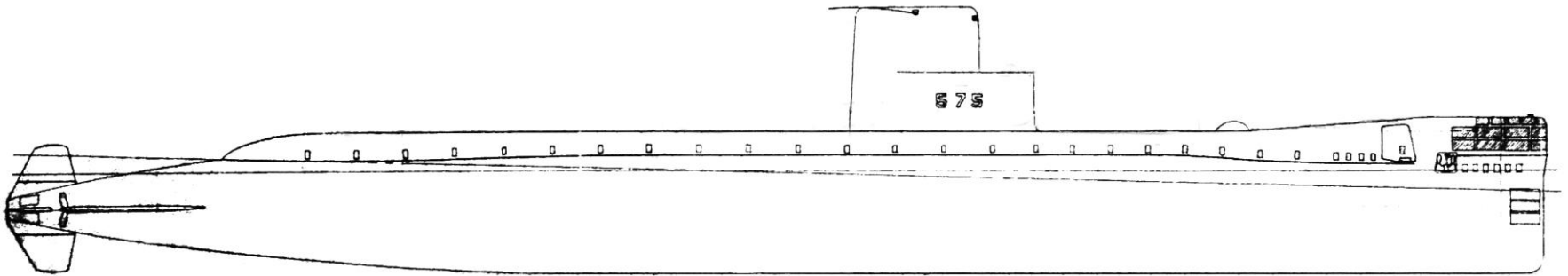

Source: adapted from Seawolf plans on <http://www.subguru.com>

- This one-ship class was the 2nd nuclear-powered sub built by the U.S.
- Propulsion:
 - Originally, 1 x S2G General Electric sodium-cooled Submarine Intermediate Reactor (SIR, Mark B) rated @ 78 MWt (est); 2 x steam turbine generators delivering a combined 15,000 hp (11 MW) to 2 x screws
 - Replaced by 1 x S2Wa Westinghouse PWR rated @ 70 MWt (est); 2 x main steam turbines delivering a total of 15,000 hp (11 MW) to 2 x screws
- Armament: 6 x 533 mm (21 inch) bow torpedo tubes

USS Seawolf (SSN-575)

- Reactor operational matters:
 - November 1956 (before initial sea trials): Rickover informed the Atomic Energy Commission that he would take steps toward replacing the reactor in *Seawolf* with a water-cooled plant similar to that in the *Nautilus*.
 - Rickover had concluded that a sodium-cooled submarine propulsion plant was, "expensive to build, complex to operate, susceptible to prolonged shutdown as a result of even minor malfunctions, and difficult and time-consuming to repair"
 - Only instance of a sodium primary coolant leak occurred while still in the shipyard.
 - Superheaters suffered from tube sheet welding cracks, which allowed high-pressure steam to leak into the low-pressure primary system and react with the sodium to form sodium hydroxide and H₂.
 - Sodium also formed radioactive tritium (³H) as a free gas in the primary system, which had to be contained.
 - 12 Dec 1958 to 30 September 1960: *Seawolf* in the Electric Boat shipyard having her S2G propulsion plant replaced with an S2Wa PWR propulsion plant, which also powered *Nautilus*.
 - 18 Apr 1959: Navy disposed of the radioactive S2G plant by sealing it in a 30-foot high stainless steel containment vessel, towing it out to sea on a barge, and then sinking the barge at a point about 120 miles due east of Maryland in 9,100 feet of water.
 - In 1980, the Navy was unable to relocate the container.

USS Seawolf (SSN-575)

- Submarine operational matters:
 - Feb 1957: Initial sea trials with S2G operating at reduced power
 - 30 March 1957: Commissioned
 - With S2G, *Seawolf* demonstrated the ability of nuclear subs to make long, independent deployments
 - 25 Sep 1957: *Seawolf* completed a submerged voyage of 6,331 mi (10,188 km)
 - 6 Oct 1958: *Seawolf* completed a 61-day submerged voyage of over 13,700 mi (22,048 km)
 - 12 Dec 1958 to 30 September 1960: *Seawolf* in the Electric Boat shipyard having her S2G propulsion plant replaced with an S2Wa PWR propulsion plant, which also powered *Nautilus*.
 - 1963: With S2Wa, *Seawolf* operated as part of the world's first nuclear task force with the aircraft carrier *USS Enterprise* (CVN-65), guided missile cruiser *Long Beach* (CGN-9), and guided missile frigate *Bainbridge* (DLGN-25)
 - 1971 – 73: In Mare Island Naval Shipyard for modifications for special operations missions, including installation of a new “special projects” hull section.
 - *Seawolf* would serve as a special operations sub until 1987, when she was decommissioned

USS Triton (SSRN/SSN-586)

1st nuclear sub to circumnavigate the globe submerged

Source: s204.photobucket.com

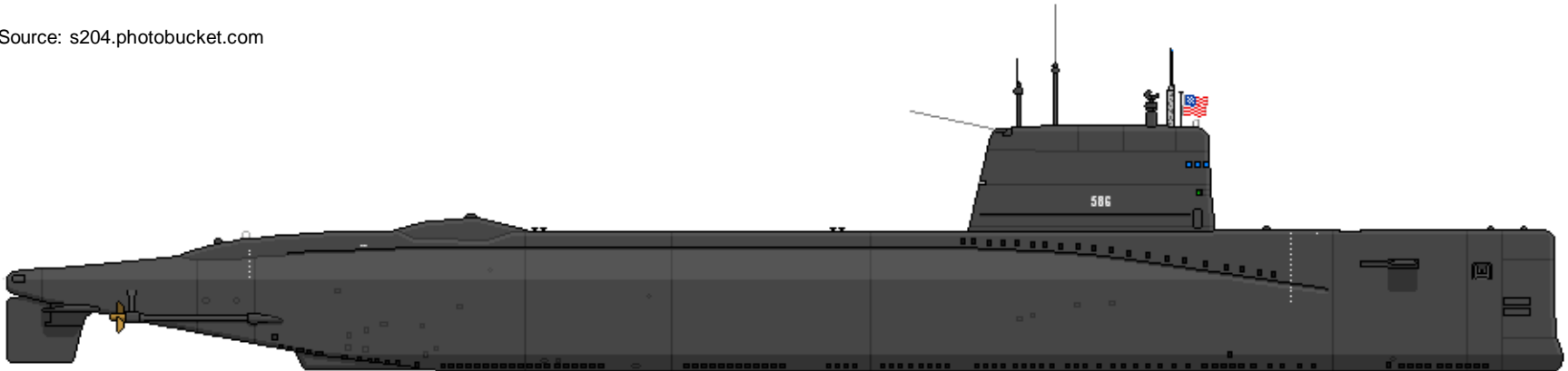

- *Triton* was to be the lead ship of a proposed class of nuclear-powered radar picket submarines (SSRNs). A December 1955 long-range naval planning report envisioned five carrier strike groups, each supported by two radar picket submarines.
 - *Triton* was a nuclear-powered counterpart to two two purpose-built diesel-electric SSRs, *Sailfish* (SSR-572) and *Salmon* (SSR-573)
 - This role became outdated with the introduction of carrier-based airborne early warning aircraft: Grumman E-1 Tracer
 - *Triton* became a one-ship class, originally with the AN/SPS-26 electronically scanned, three-dimensional (3-D) radar system mounted on a hull design that was similar to its diesel-powered SSR counterparts.
 - Hull design was intended to provide good surface sea-keeping qualities for the radar picket role. In comparison to other U.S. nuclear subs, *Triton* had high reserve buoyancy (30%).

USS Triton (SSRN/SSN-586)

1st nuclear sub to circumnavigate the globe submerged

- Propulsion: 2 x S4G General Electric PWRs rated @ 78 MWt, arranged fore-and-aft in the hull; 2 x steam turbines rated @ a combined 34,000 hp (est), driving 2 x shafts
 - *Triton* was the only U.S. sub with two reactors
 - Both reactors were located in the same reactor compartment. The #1 (forward) reactor supplied steam to the forward engine room and the starboard propeller shaft. The #2 (aft) reactor supplied steam to the aft engine room and the port propeller shaft.
 - The two steam plants could be cross-connected as required.
- Armament: 6 x 533 mm (21") torpedo tubes; 4 x bow tubes, 2 x stern tubes.
- Operational matters:
 - 24 Feb – 25 Apr 60: Operation Sandblast, *Triton* circumnavigates the globe submerged.
 - 1 March 1961: *Triton* re-classified as an SSN.
 - Refueled during her 1962–1964 overhaul.
 - 3 May 1969: *Triton* decommissioned; 1st U.S. nuclear sub to be taken out of service.



Source: [http://content.wow.com/wiki/USS_Triton_\(SSRN-586\)](http://content.wow.com/wiki/USS_Triton_(SSRN-586))

Operation Sandblast

USS Triton, 1st submarine to circumnavigate the globe submerged

24 Feb – 25 Apr 60,
30,752 mi (49,491 km;),
in 60 days and 21 hours,
average speed 18 knots.

Triton CO: Capt. Edward L. Beach

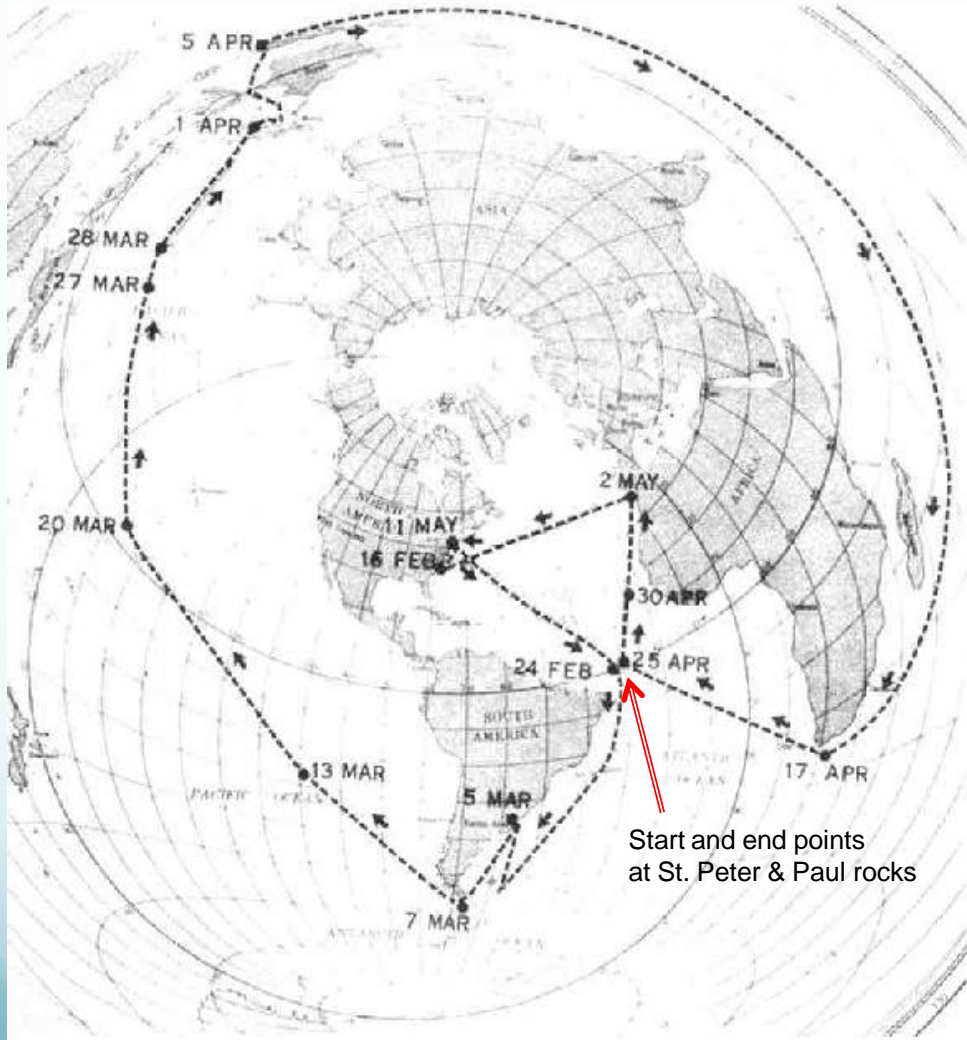

Start and end points
at St. Peter & Paul rocks

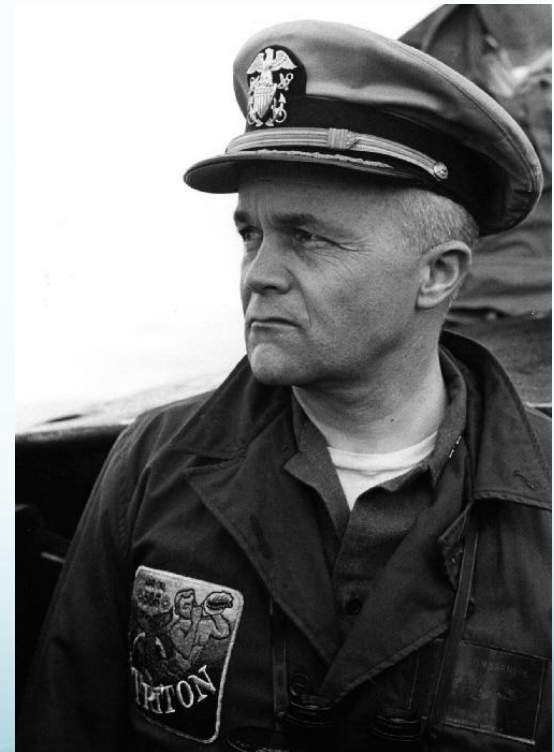

Skate-class (SSN-578)

first series-produced nuclear subs

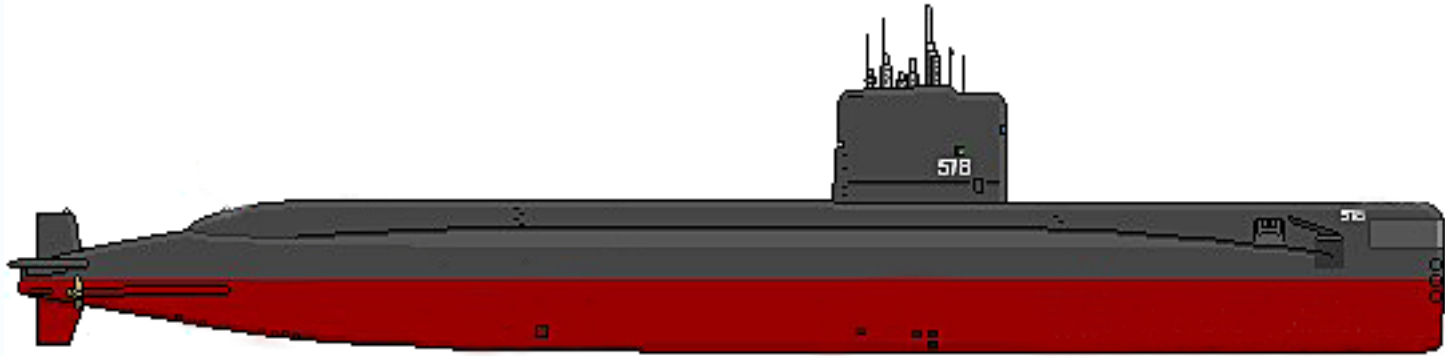

Source: <http://warshipsresearch.blogspot.com>

- First series-produced U.S. nuclear sub; 4 boats in this class.
 - This hull design was an evolution of the Tang-class diesel-electric sub hull.
- Propulsion: 1 x S3W or S4W Westinghouse PWR rated @ 38 MWt (est); 2 x main steam turbines delivering a total of 7,300 hp (5.4 MW) to 2 x screws
- Armament: 8 x 533 mm (21") bow torpedo tubes, 6 bow tubes & 2 stern tubes
- Operational matters:
 - All subs in this class were Arctic-capable (hardened sail, under ice sonar, inertial navigation)
 - *Skate* was the first sub to surface at the North Pole on on 17 March 1959.
 - The other three subs in this class, *Sargo*, *Seadragon* & *Swordfish*, all reached the North Pole and played an important role in mapping the Arctic Ocean and developing practices for safe under-ice operation.

USS Skate (SSN-578)

11 Aug 1958: 2nd submarine under the North Pole
17 March 1959: 1st submarine to surface at the North Pole



Capt. James Calvert

Source: US Navy



USS SKATE AT NORTH POLE, MARCH 17, 1959

Source: <http://archive.constantcontact.com>

The crew held a ceremony for the late Arctic explorer Sir Hubert Wilkins and spread his ashes at the North Pole

USS Tullibee (SSN-597)

first turbo-electric drive nuclear sub



Source: <http://warshipsresearch.blogspot.com>

- This one-ship class is a result of the 1956 Project Naboska, which emphasized the need for deeper-diving, ultra-quiet submarine designs using long-range sonar.
 - 1st sub with a bow-mounted spherical sonar array torpedo tubes located amidship, angled out from the hull. This became the U.S SSN standard starting with the Permit-class.
 - 1st sub with turbo-electric drive with no reduction gear; not repeated until *USS Glenard P. Lipscomb* (SSN-685)
 - Smallest SSN built by the U.S.
 - Maximum depth (test depth): 700 ft
- Propulsion: 1 x S2C Combustion Engineering PWR rated @ 13 MWt (est); 2 x steam turbine generators delivering a combined 1.86 MW (2,500 shaft horsepower) to the electric drive for a single propeller.
- Armament: 4 x 533 mm (21 inch) mid-ship torpedo tubes

USS Tullibee (SSN-597)



Operational matters:

- Quietest of the early generation of U.S. nuclear subs.
- Three vertical fins housed the PUFFS (Passive Underwater Fire-control Feasibility Study) sonar sensors.
- Operated extensively in the Atlantic & Mediterranean, including numerous fleet exercises and sonar development activities.
- Decommissioned in 1988 after traveling about 325,000 nautical miles (602,000 km).

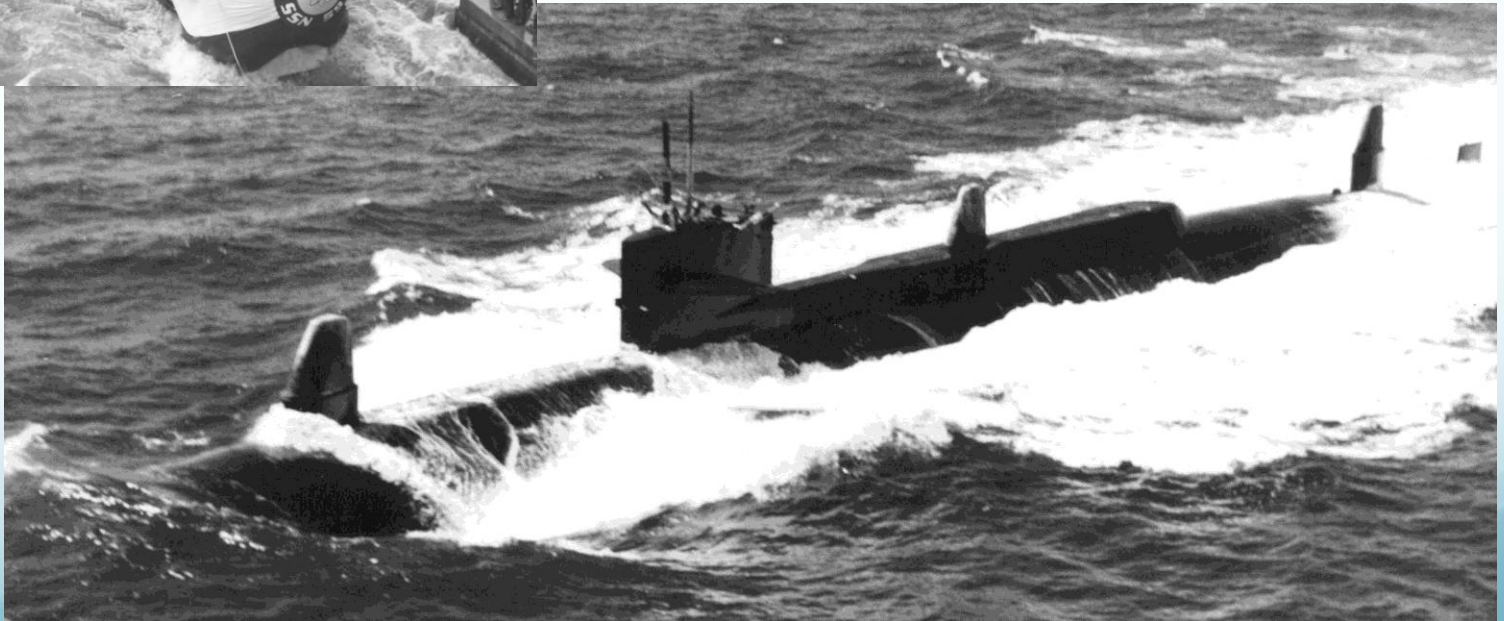

Skipjack-class SSN



Source:www.subsim.com

- The six boat Skipjack-class was built by four different contractors.
- Novel hull design:
 - 1st nuclear sub with a streamlined Albacore-style “body-of-revolution” hull, which greatly improved underwater performance, but reduced sea-keeping on the surface
 - 1st use of high-strength HY-80 steel in hull construction. Single-hull, with a double hull containing the ballast tanks only around the bow torpedo room and the mid-ship Auxiliary Machinery Room.
 - 1st sub built with sail plans instead of conventional bow planes. This arrangement cut down on flow-induced noise near the bow sonar arrays. This feature was used on all U.S. nuclear submarines until the Improved Los Angeles (688i)- class in 1988.
- Propulsion: 1 x S5W reactor rated @ 78 MWt; 2 x main steam turbines delivering a combined 15,000 shaft horsepower (11.19 MW) to a propeller. This was the 1st class of subs to use the S5W reactor.
- Armament: 6 x 533 mm (21 inch) bow torpedo tubes; Mk 14, Mk 16, Mk 37 & Mk 48 conventional torpedoes; Mk 45 ASTOR nuclear torpedoes; mines
 - Maximum weapon load was 24 torpedoes, or a mix of torpedoes and mines

Skipjack-class SSN

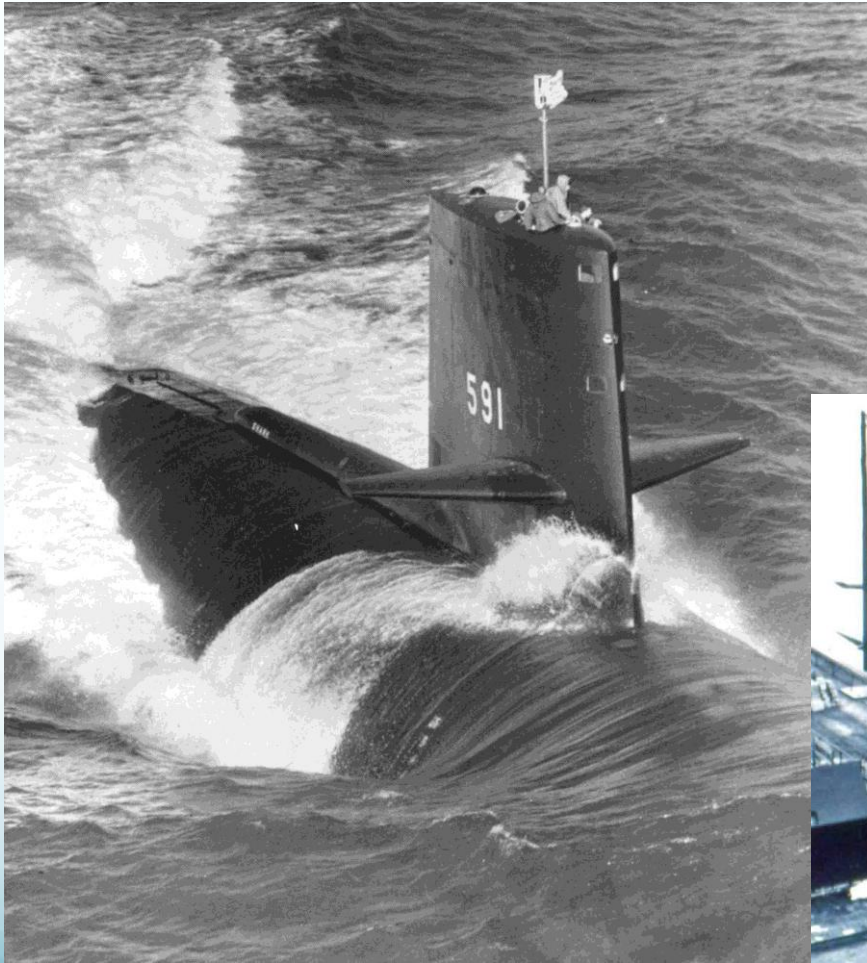

Operational matters:

- *USS Scorpion* (SSN-589) was lost at sea in the Atlantic on 22 May 1968
- All Skipjack-class subs were commissioned in a two year period: 1959 – 1961. The last boat in the class was decommissioned in 1990.

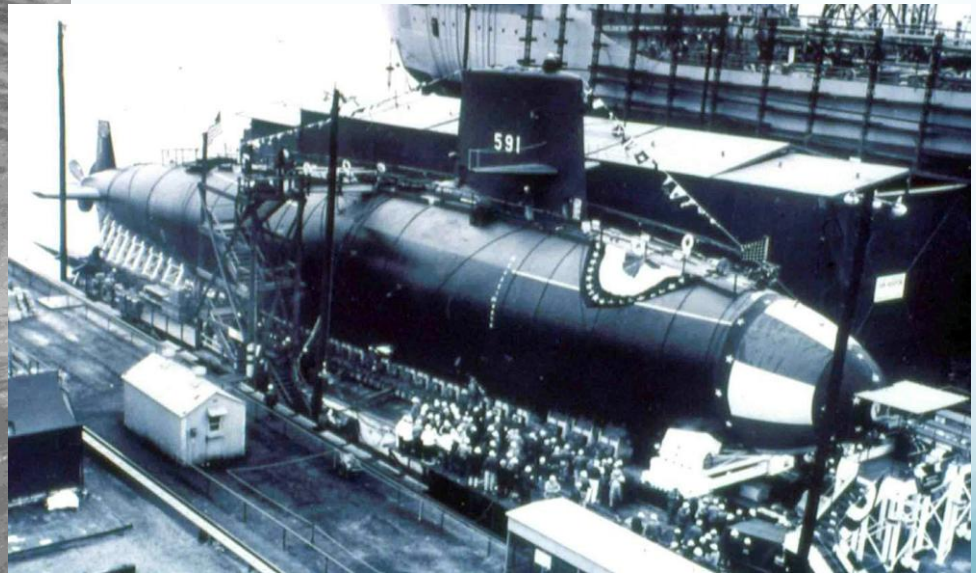

Source, two photos: www.navsourc.org/archives

Skipjack-class SSN

Notional internal arrangement

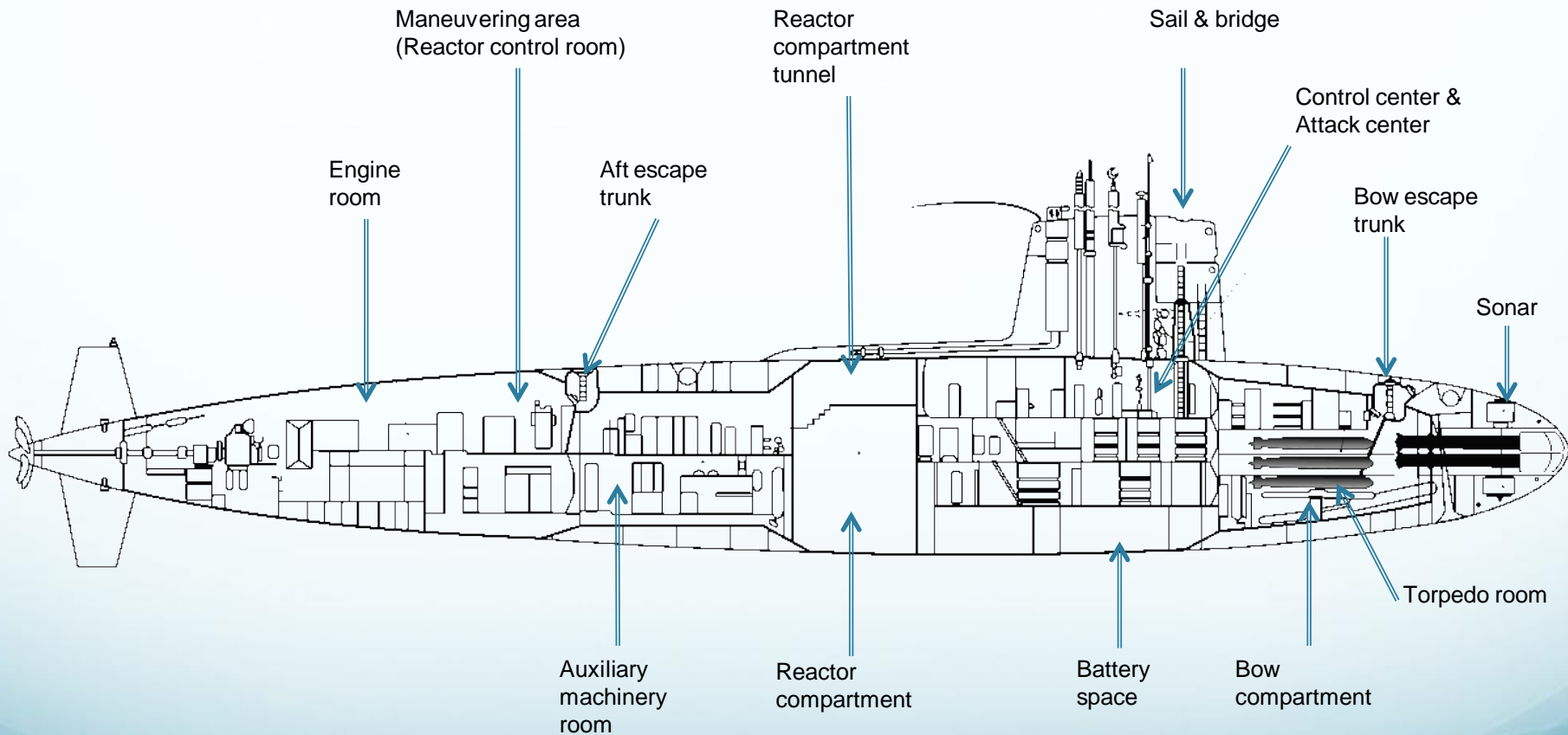

Loss of the *USS Scorpion*

- *USS Scorpion* (SSN-589) sank on 22 May 1968 in the mid-Atlantic, southwest of the Azores, while returning from a Mediterranean deployment.
 - Water depth is about 9,800 ft (3,000 m).
- Numerous acoustic events subsequently associated with the sinking were recorded by multiple stations.
- The 1968 Navy Court of Inquiry offered findings of fact and opinions, including:
 - There is no incontrovertible proof of the exact cause of *Scorpion's* loss.
 - There is no evidence that loss of *Scorpion* was the result of an unfriendly act.
 - Gamma radiation readings taken at the ocean floor and of a bottom core sample taken at *Scorpion's* location, gave only normal background readings. Water samples taken in close proximity to the Reactor Compartment gave only normal background readings.
 - Evidence supports the finding that no radiological hazard resulted from the loss of *Scorpion*.
- Numerous theories for the loss of *Scorpion* have been proposed.
- U.S. Navy has acknowledged that it periodically visits the site to conduct testing for the release of radioactive material from the S5W reactor core or the two Mk 45 ASTOR nuclear torpedoes still in the wreckage, and to determine whether the wreckage has been disturbed.

Permit (594) class SSN

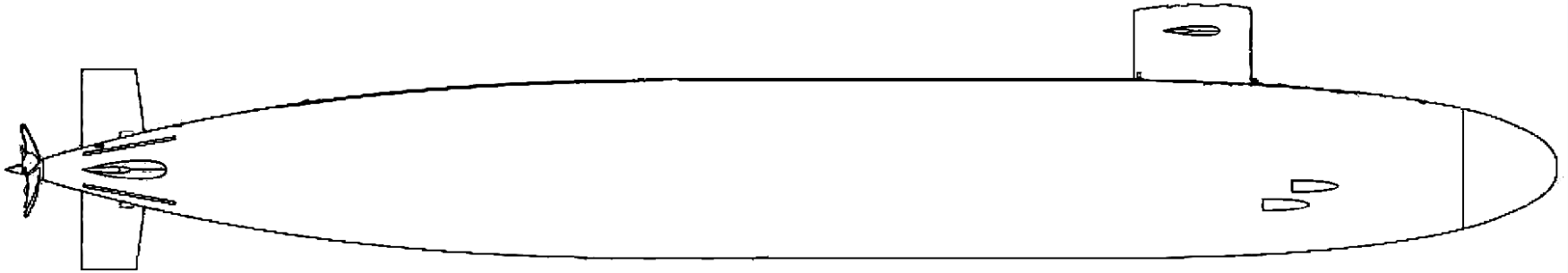

Source: Adapted from <http://www.the-blueprints.com/>

- The 14 boat Permit-class was built by five different contractors.
 - Originally named the Thresher-class, after the lead boat, *USS Thresher (SSN-593)*, which was lost with all hands due to flooding during deep-dive testing in the Atlantic east of Cape Cod, MA on 10 April 1963.
- Significant improvements over Skipjack-class:
 - Longer, cylindrical hull shape, with greater strength, allowed diving to greater depth.
 - This basic hull design became the standard shape for later generations of U.S. nuclear subs.
 - Small sail for reduced hydrodynamic drag, but this allowed only one periscope & few electronic masts.
 - BQQ-2 bow sonar sphere and mid-ship torpedo tubes
 - Many sound-quieting improvements over Skipjack-class:
 - 1st U.S. nuclear subs to mount heavy rotating machinery on sound-isolated “rafts”
 - 1st use of 7-bladed propeller on a nuclear sub, for quieter (but slower) operation
- Powerplant: 1 x S5W reactor rated @ 78 MWt; 2 x main steam turbines delivering a combined 15,000 shaft horsepower to a single propeller.

Permit (594) class SSN

- Armament: 4 x 533 mm (21 inch) mid-ship torpedo tubes; initially Mk 37 & later Mk-48 conventional torpedoes; Mk 45 ASTOR nuclear torpedoes; SUBROC anti-submarine nuclear missile; Harpoon anti-ship cruise missiles; mines
 - 1st class fitted with the Mark 113 fire control system that enabled the use of SUBROC
 - Maximum weapon load was 23 torpedoes/missiles or, up to 42 Mk-57, -60, or -67 mines. Any mix of mines, torpedoes, and missiles could be carried.
- Operational matters:
 - Mid-life upgrades included BQQ-5 sonar suite with retractable towed-array, Mk-117 fire control system
 - The Permit-class boats were all commissioned in a 7-year period from 1961 – 1968. The last Permit-class boat was decommissioned in 1996.

Installation of the *USS Permit* bow spherical sonar array

Submarine bow compartment pressure hull

Submarine bow outer hull

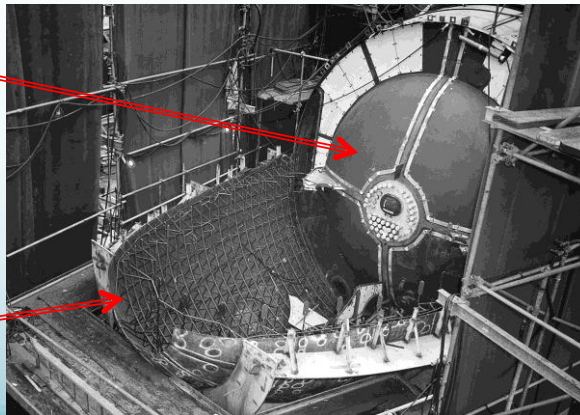

Source, two photos: navsource.org/archives/

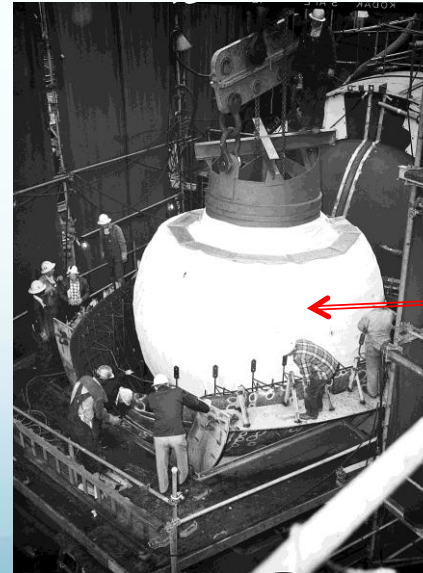

BQQ-2 spherical sonar array in the free-flood area enclosed by the bow outer hull.

Permit-class SSN

Notional internal arrangement

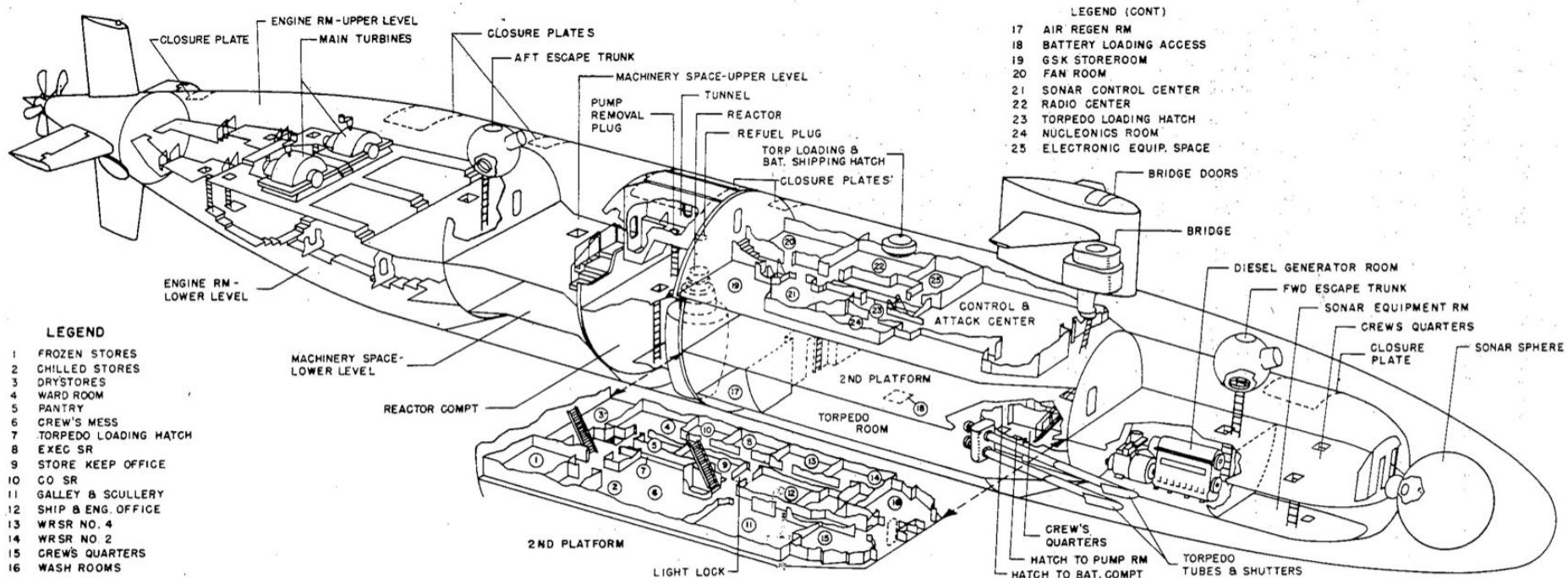

Source: <http://navsource.org/archives/>

Permit-class SSN

Notional internal arrangement

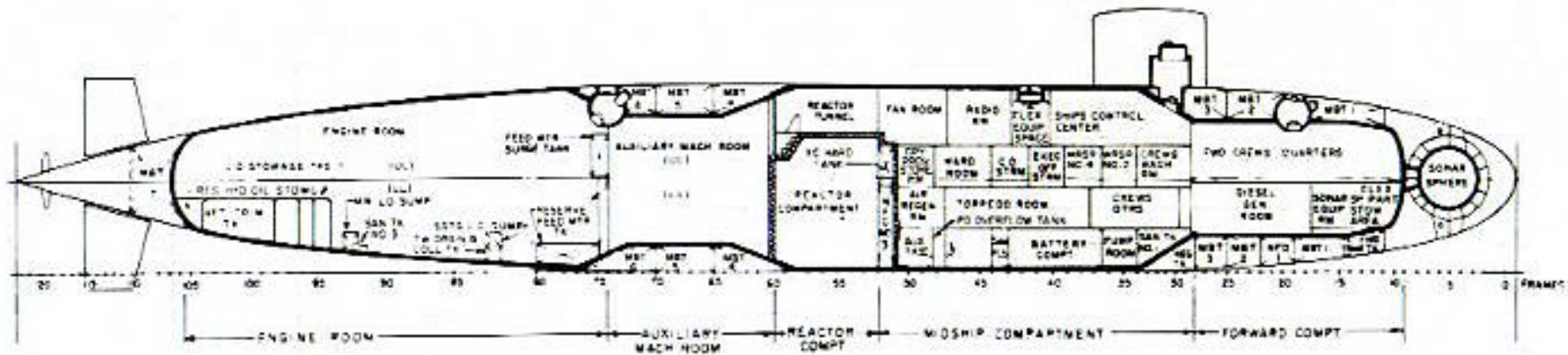

Source: www.reddit.com/r/AskHistorians

Permit (594) class variations

Style 1



Style 1: Short hull; Small sail

593 Thresher	604 Haddo
594 Permit	605 Tinosa
595 Plunger	607 Dace
596 Barb	612 Guardfish
603 Pollack	

Style 2



Style 2: Short hull; Large sail

621 Haddock

Style 3



Style 3: Long hull; Large sail

613 Flasher
614 Greenling
615 Gato

Style 4



**Style 4: Long hull; Small sail;
Double Screw**

605 Jack

Loss of the *USS Thresher*

- *USS Thresher* (SSN-593) sank in 8,500' of water in the Atlantic, about 220 miles off of Cape Cod, on 10 April 1963 during a deep dive test being monitored from the Navy submarine rescue vessel *USS Skylark*.
- With *Thresher* initially at about ½ test depth (about 650', 200 m), neutrally buoyant, at relatively low speed:
 - 9:03 AM: Underwater telephone message from *Thresher* reports, "Experiencing minor problem. Have positive angle," and then, "Attempting to blow." For the next 10 minutes *Skylark* attempts to make contact with *Thresher*, but there is no reply.
 - 9:17 A.M. *Skylark* receives a garbled message that ends with the distinct words: "...test depth." *Thresher's* underwater telephone remains open and *Skylark's* navigator hears the distinctive groans and clanks as *Thresher* starts to break up.
- The likely scenario for this accident is as follows:
 - An initial leak most likely occurred in a silver-braided joint in an engine room seawater system.
 - Saltwater spray on electrical components caused short circuits, reactor shutdown, and loss of propulsion power.
 - *Thresher* did not have enough forward momentum to drive to the surface using its planes.
 - An "emergency blow" was initiated to rapidly blow all main ballast tanks. However, as the high-pressure air expanded, it cooled, and moisture in the compressed air froze on in-line strainers in the emergency blow lines. This slowed or stopped the emergency blow.
 - Propulsion was not restored and the ship sank deeper as flooding continued.
 - The *Thresher* broke up and all 129 aboard were lost.

SUBSAFE Program

- A Judge Advocate General (JAG) Court of Inquiry into the *Thresher* accident was conducted.
 - The JAG report contained 166 Findings of Fact, 55 Opinions, and 19 Recommendations.
 - The recommendations were technically evaluated and incorporated into the Navy's newly-established SUBSAFE design and operational requirements, which were applied to all operating and new-construction subs and continue to be applied to all new design subs.
- The purpose of the SUBSAFE Program is to provide maximum reasonable assurance of watertight integrity and recovery capability.
 - The SUBSAFE boundary is defined on a per-boat basis in the SUBSAFE Manual and depicted diagrammatically in the SUBSAFE Certification Boundary Books.
- The Navy's first task was to systematically establish SUBSAFE culture at all levels.
- A SUBSAFE certification process was established for all items related to the SUBSAFE boundary.
 - This resulted in substantive changes to ship systems, equipment, and operating procedures
- A SUBSAFE certification maintenance process was established to ensure the continuing integrity of the SUBSAFE boundary throughout the operating life of each boat.
- An Audit process provides the necessary confidence that the SUBSAFE Program is meeting its intended purpose and may identify opportunities for improvement.

Deep Submergence Rescue Vehicle (DSRV)



Source: www.navy.mil



Source: www.murdoconline.net

- Development of the DSRV was a reaction to the Thresher accident.
- Two DSRVs, *Avalon* & *Mystic*, were commissioned in the early 1970s.
- The two air-transportable, battery-powered DSRVs were 50 feet (15 m) long, 8 feet (2.4 m) in diameter, and weighed 37 tons.
- DSRVs were capable of descending to 5,000 feet (1,500 m) below the surface and could carry 24 passengers at a time in addition to its crew.
- Many U.S. nuclear subs were configured to carry a DSRV to a rescue location or other operations site.
- The DSRVs were never required to conduct an actual rescue operation. *Avalon* was retired in 2000 and *Mystic* in 2008.

Deep Submergence Rescue Vehicle (DSRV)

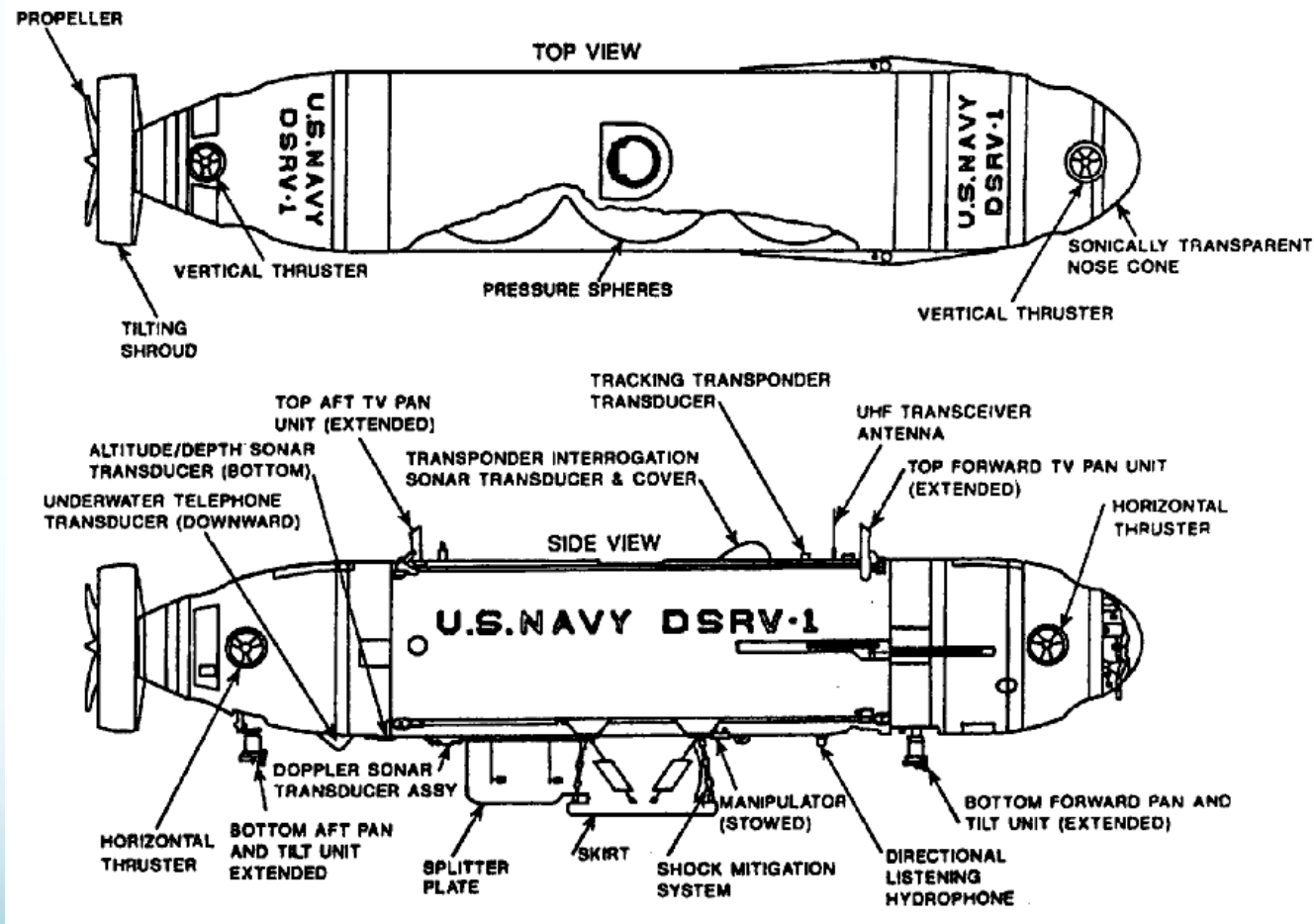

Source: www.globalsecurity.org

Sturgeon (637)-class SSN

Source: usnavymuseum.org



- The 37 Sturgeon-class boats were built by seven different contractors and commissioned in a 7-year period from 1967 – 1975.
 - Bigger sails, longer hulls & more electronics spaces than Permit-class boats.
 - These were all capable of operating in ice-covered Arctic waters.
- There were two basic versions:
 - 28 x “short-hull” (last was SSN-677, *USS Drum*), and 9 x “long-hull” boats incorporating a 3 meter (10 ft) hull extension (starting with SSN-678, *USS Archerfish*).
 - Six of the long-hull boats were equipped to handle a Dry Deck Shelter (DDS) for special operations forces.
 - One long-hull boat (SSN-683, *USS Parche*) was further modified to take over the special operations missions conducted by *Halibut* and *Seawolf*.

Sturgeon (637)-class SSN

- Powerplant: 1 x S5W reactor rated @ 78 MWt; 2 x main steam turbines delivering a combined 15,000 shaft horsepower to a single propeller.
- Armament: 4 x 533 mm (21 inch) mid-ship torpedo tubes; Mk-37 & Mk-48 conventional torpedoes, Mk 45 ASTOR nuclear torpedoes; SUBROC anti-submarine nuclear missile; Harpoon anti-ship cruise missiles, or Tomahawk land attack cruise missile; also Mark 60 CAPTOR or Mark 67 mines
 - Maximum weapon load was 21 torpedoes/missiles or a mix with mines.
- Operational matters:
 - All Sturgeon-class subs were Arctic capable, with hardened sails, under-ice sonar, and fairwater planes that rotated vertical for penetrating the ice.
 - Sturgeon-class subs tested the first Harpoon and Tomahawk cruise missiles, towed-array sonar, digital sonar signal analyzer, and satellite communication antenna
 - All Sturgeon-class subs were commissioned in an eight year period: 1967 - 1975. The last Sturgeon-class SSN was decommissioned in 2005.



Source: www.pbs.org

Sturgeon-class SSN

External & internal arrangement

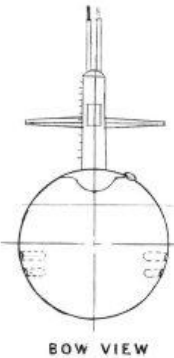
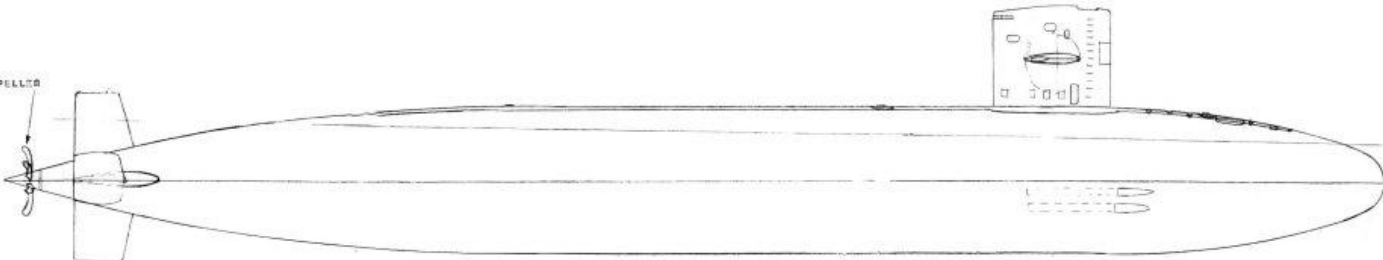
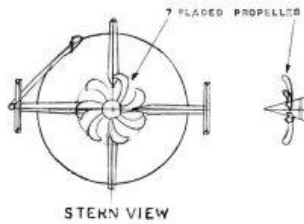
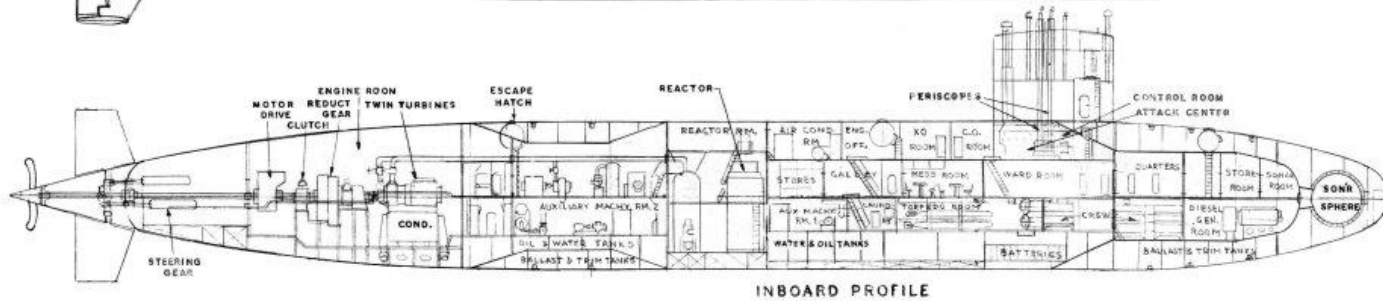
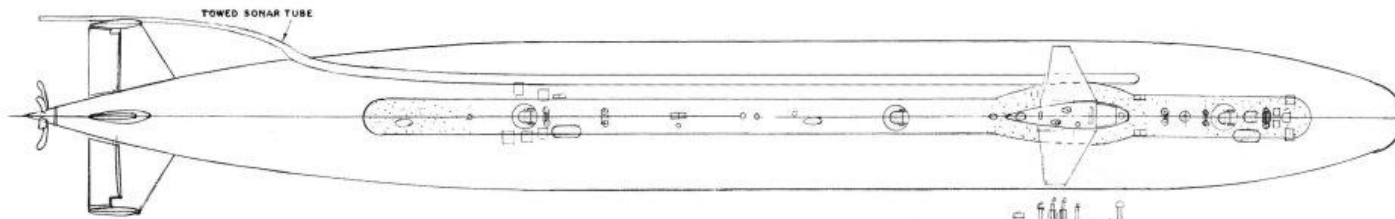

Driving a Sturgeon-class SSN

Ship control station
In the Control Room

Engineering control station
In the Maneuvering Room

Ballast Control Panel



Source: www.subsim.com

Source: <http://www.emmitsburg.net/>

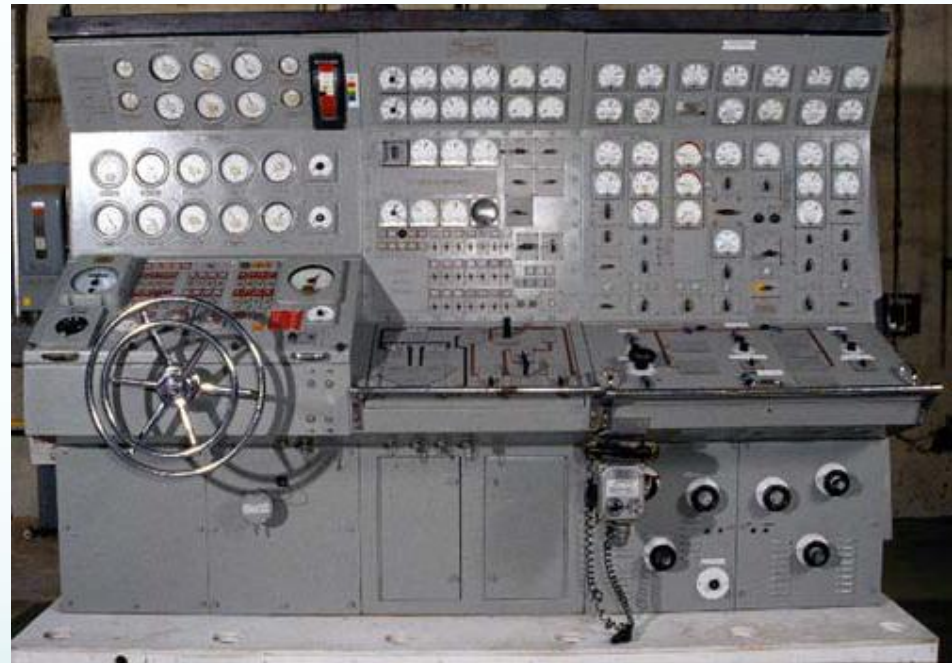

Fairwater (bow) plane,
Stern plane &
Rudder controls,
Engine order telegraph

Throttle
Control
Panel
(TCP)

Reactor
Plant
Control Panel
(RPCP)

Electric
Plant
Control Panel
(EPCP)

Sound velocity profile (SVP) creates the deep sound channel

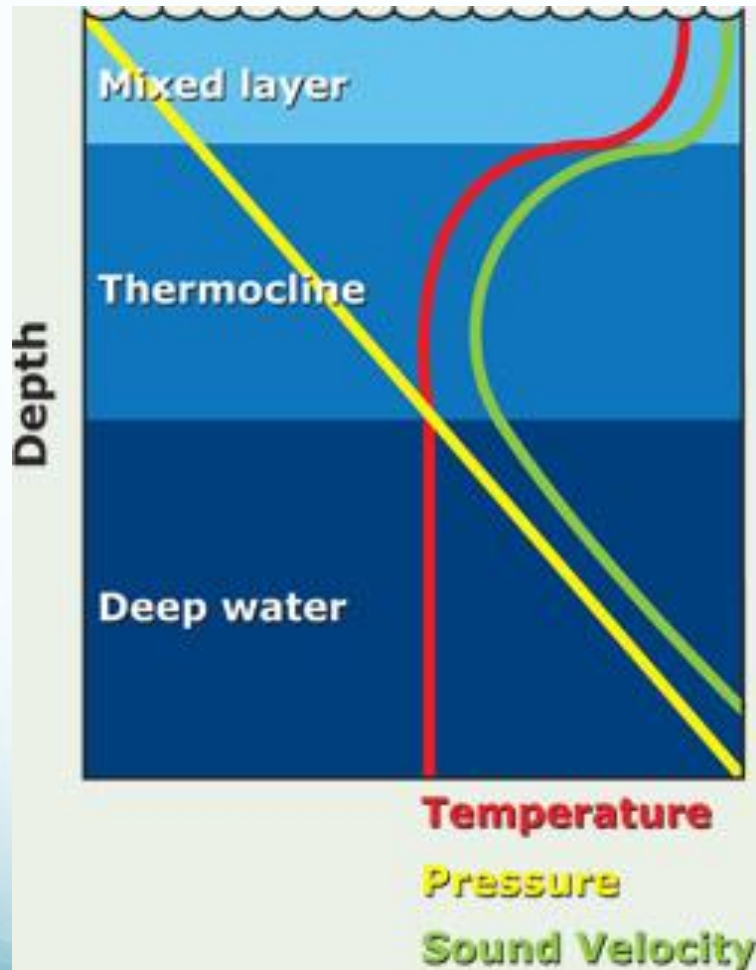

Source: <http://www.divediscover.whoi.edu>

- The speed of sound in the ocean varies because of the combined effects of water temperature and pressure, as shown in the adjacent vertical Sound Velocity Profile (SVP) chart.
- In this example SVP, there are two areas where sound travels relatively faster:
 - In warmer water near the surface, and
 - In deep water where temperature is almost constant and pressure keeps increasing with depth.
- Between these two layers is the thermocline, where temperature changes rapidly over a depth of 500 to 1,000 meters and creates a local minimum sound velocity in the SVP.
 - Acoustic waves from a source in the thermocline are refracted as they radiate away from the source.
 - As acoustic waves approach the surface they are bent back toward the bottom, and as they approach the ocean bottom they are bent back toward the surface.
- Sound travels a great distance in the deep ocean where it gets trapped in this “deep sound channel”, which acts as an acoustic wave guide and conducts sound very efficiently; particularly low frequency sound.

Depth of the axis of the deep sound channel (SOFAR channel)

- The axis of the deep sound channel is at the minimum velocity in the SVP.
- In low to middle latitudes, the deep sound channel is between 600 and 1200 meters below the sea surface. It is closer to the surface in higher latitudes, and at latitudes greater than about 60° N/S, it reaches the surface.

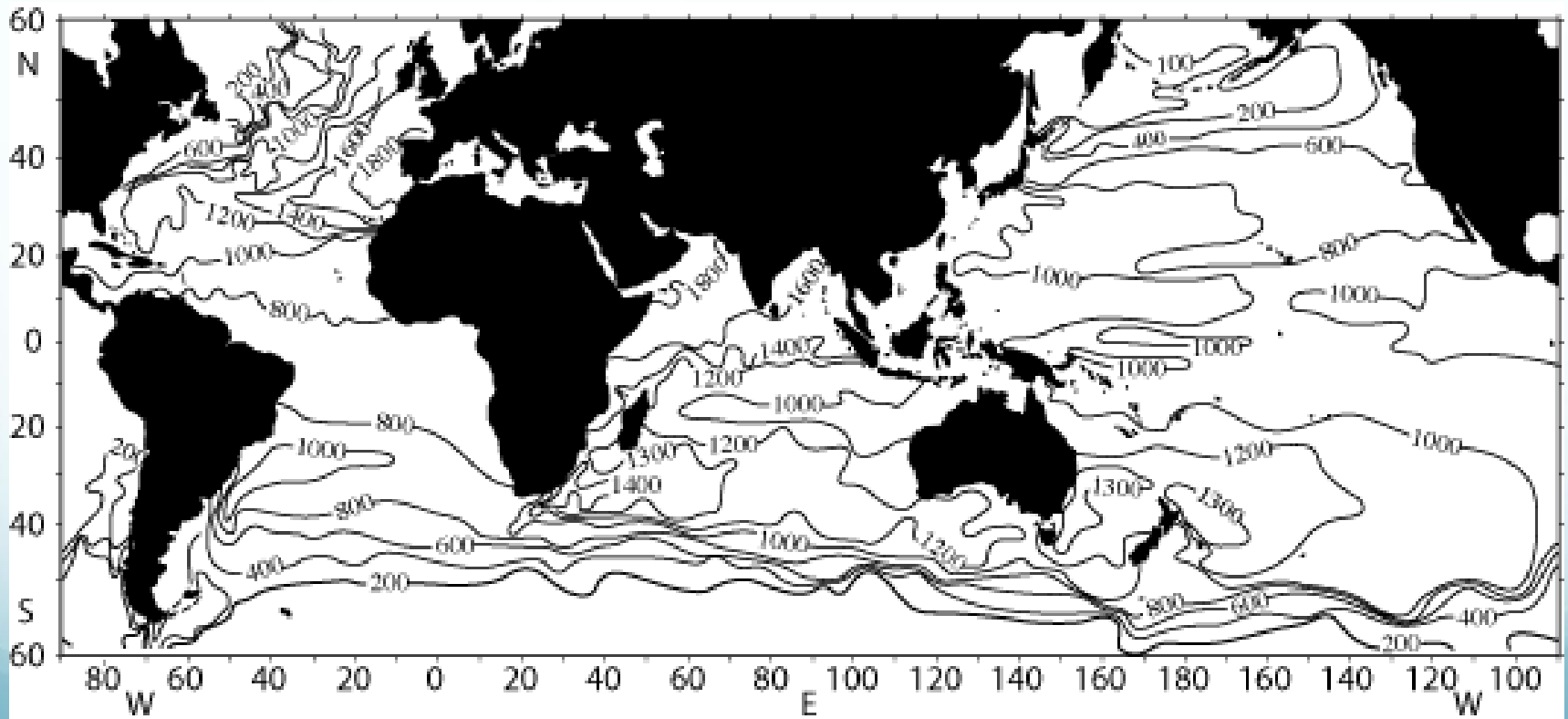

Sound Surveillance System (SOSUS)

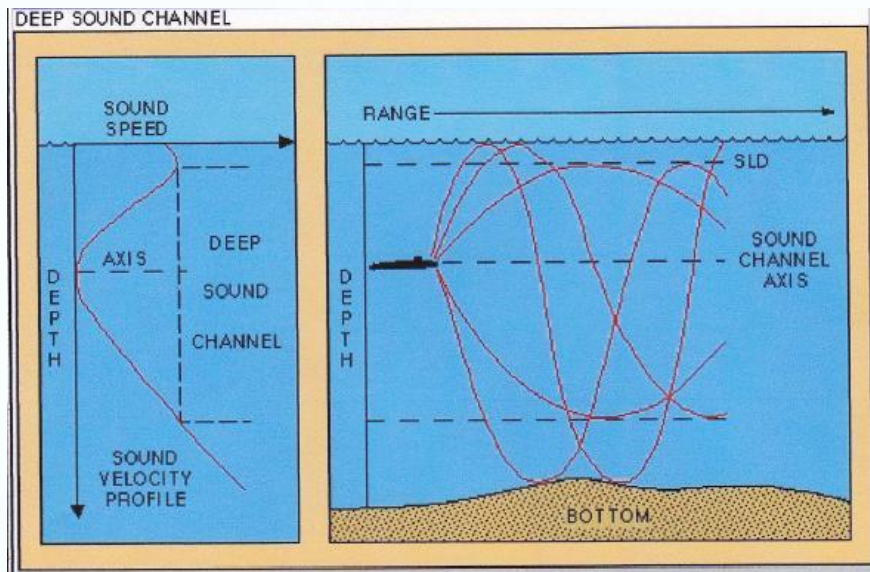

Source: <http://www.oc.nps.edu/~bird/oc2930/acoustics/soundchannel.html>

Source: <http://www.divediscover.whoi.edu/>

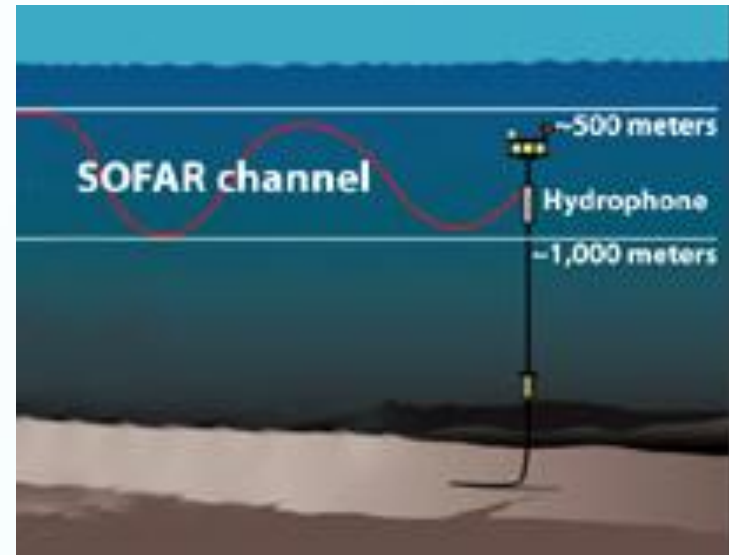

- SOSUS was a highly-classified global network of fixed hydrophone arrays that formed the backbone of the U.S. long-range anti-submarine detection capability.
- Started in 1951 with Project Jezebel, which proved the practicality of SOFAR (SOund Fixing and Ranging) with hydrophones in the deep sound channel (SOFAR channel).
- Operational hydrophone arrays were first installed along the U.S. east coast starting in 1952. By 1981, thirty-six stations had been installed in many locations.

Sound Surveillance System (SOSUS)

- SOSUS arrays and signal processing:
 - Very long (1,000 foot) hydrophone arrays could detect even the lowest frequencies being generated by submarines at ranges of hundreds of miles.
 - Some of the arrays were positioned to monitor natural “choke points” for transiting Soviet submarines (i.e., the Greenland-Iceland-UK gap; Straits of Gibraltar).
 - Low Frequency Analysis and Ranging (LOFAR) involved spectral analysis of the low-frequency tonals embedded in the broadband noise from a submarine.
 - These tonals form acoustic signatures that are characteristic of particular submarines.
- Examples of early SOSUS tracking capabilities:
 - 1961: The east coast SOSUS array tracked the *USS George Washington* (SSBN-598) as she transited for one of her first deterrent patrols.
 - 1962: SOSUS station in Barbados detected a Soviet Hotel/Echo/November (HEN)-class sub as it passed through the Greenland-Iceland-United Kingdom (GIUK) gap.
 - 1968: SOSUS data detected the sinking north of Hawaii of Soviet Golf-class submarine K-129.
 - SOSUS data facilitated the discovery of the wreckage site by the *USS Halibut* and the subsequent clandestine retrieval attempt conducted under *Project Azorian*.
 - 1968: SOSUS data helped find the *USS Scorpion* (SSN-589), which sank in the mid-Atlantic.
 - Wreckage was found about 3 miles from where SOSUS computers had predicted.

Sound Surveillance System (SOSUS)

- Challenges to SOSUS:

- Starting with the Soviet Delta-class SSBNs, which were equipped with very long range strategic missiles, the SSBN patrol areas could be in the Arctic Ocean, away from SOSUS arrays.
- Information leaked to the Soviet Navy by the Walker/Whitworth spy ring enabled the Soviets to make substantial gains in reducing the radiated noise from their later modes subs such as the Victor III and Akula-class SSNs.

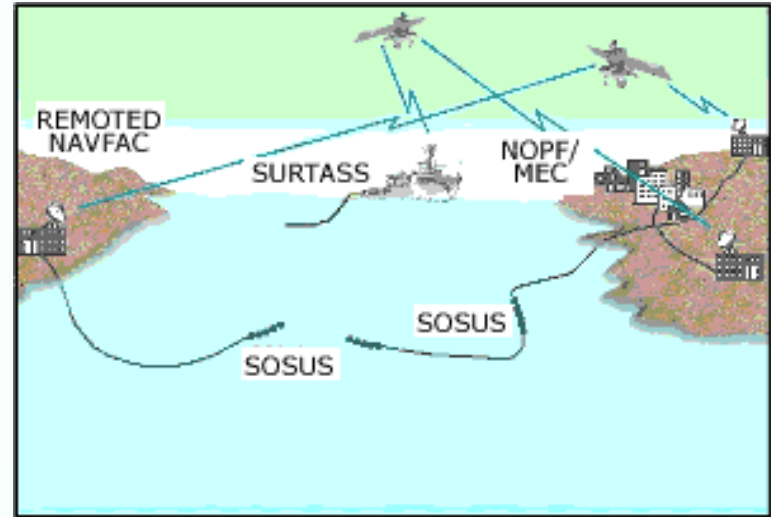

Source: <http://www.dosits.org/technology/>

- SOSUS was supplemented with Surveillance Towed Array Sensor System (SURTASS) ships starting in 1984.
- With the end of the Cold War, the U.S. Navy offered the civilian scientific community “dual use” of SOSUS for use in ocean environmental monitoring.
- The total investment in SOSUS is estimated at more than \$16 billion.
- The number of operating SOSUS hydrophone arrays and land stations (NAVFACs) has been reduced from the Cold War peak.
- SOSUS remains a component of the Integrated Undersea Surveillance System.

Surveillance Towed Array Sensor System (SURTASS)

- SURTASS/CLFA is a low frequency, passive and active acoustic surveillance system installed on Tactical Auxiliary General Ocean Surveillance Ships (T-AGOS) as a component of the Integrated Undersea Surveillance System (IUSS).
 - SURTASS provides passive detection of quiet nuclear and diesel subs and enables real-time reporting of surveillance information to fleet commanders.
 - CLFA is a low-frequency active sonar system for active detection of quiet submarines operating in environments that support active sonar use.



Source: <https://en.wikipedia.org>

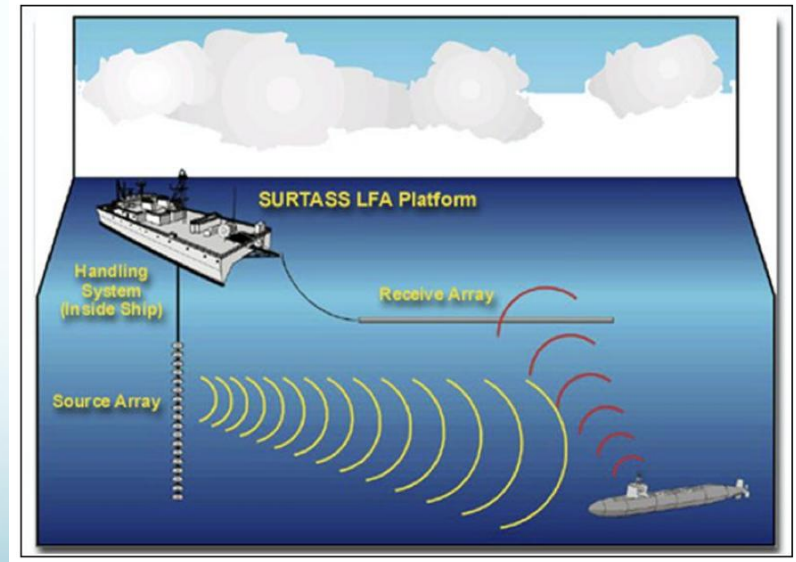

Source: <http://www.surtass-lfa-eis.com>

Submarine Radiated Noise

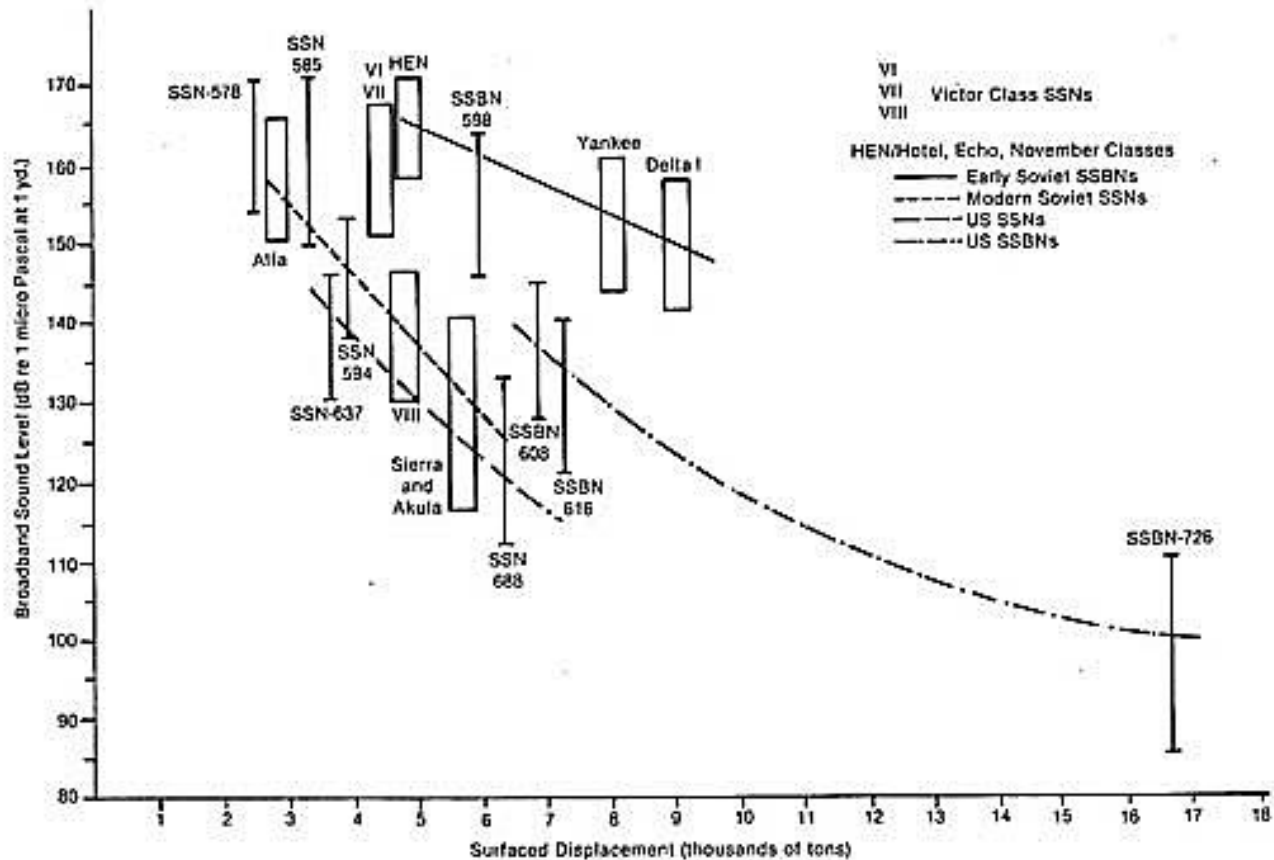

Figure A6-7. Broadband sound level versus surfaced displacement.

Note: Trend lines for different generations of quieting technology are identified.

Holystone

- HOLYSTONE, which also has been known as PINNACLE, BOLLARD, and most recently as BARNACLE, began in 1959 and involved the use of specially-equipped submarines to collect electronic, communications, acoustic, photographic, and other intelligence.
- Program's original focus was to provide military intelligence on the Soviet Union.
 - Some missions intercepted a broad range of radio-frequency transmissions (voice & data transmissions, radar emissions).
 - Some missions captured digital noise spectra (i.e., machinery, steam flow, hydrodynamic flow and other noises) produced by other submarines encountered during the mission.
 - These correlated noise data enabled Naval Scientific and Technical Intelligence Center (now the Naval Intelligence Support Center) to develop a methodology to identify individual submarines, even those tracked at very long range.
 - Some missions observed and photographed various fleet and/or individual ship activities, including sea-launched missile tests.
 - Some missions mapped and characterized the hydrographic environment.
- To reduce the likelihood of detection during a mission, active radio-frequency and sonar equipment was not used in the assigned patrol area.
- Recommended reading:
 - *Blind Man's Bluff: The Untold Story of American Submarine Espionage*, 1998, C. Drew, S. Sontag, A. Drew
 - *Crazy Ivan: Based on a True Story of Submarine Espionage*, 2000, W. Craig Reed, William Reed

U.S. submarine-launched anti-submarine nuclear weapons

Weapon	Years in service	Weight	Length	Diameter	Propulsion	Range / guidance	Warhead
Mk-45 ASTOR torpedo	1963 - 1976	1,089 kg (2,400 lb)	5.76 m (18.9 ft)	480 mm (19")	Electric	3.2 – 12.9 km (2 – 8 mi) / wire guided	W34 @ 11 kT
UUM-44 SUBROC anti-sub missile	1965 -1989	1,814 kg (4,000 lb)	6.7 m (22 ft)	533 mm (21")	Solid rocket	54.7 km (34 mi) / inertially guided	W55 @ 1 - 5 kT depth charge

ASTOR (Anti-Submarine Torpedo)



Source: <https://en.wikipedia.org/>

SUBROC

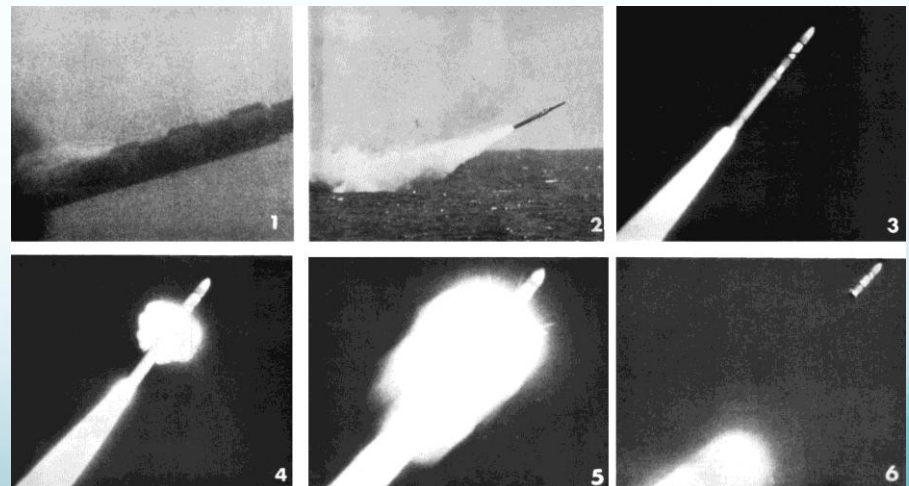

Source: <https://en.wikipedia.org/>

New technologies tested on one-of-a-kind operational SSNs

- *USS Jack (SSN-605)*:
 - Considered part of Permit class. 1st nuclear sub with a directly-coupled main turbine (no reduction gear) driving contra-rotating props on concentric shafts.
 - Adequate shaft sealing (i.e., keeping seawater from leaking along the rotating shaft and into the sub), was an on-going problem
 - 20' (6.1 m) longer than standard Permit-class subs to accommodate the new drive train.
 - Performance improvement did not meet expectations based on Albacore test results.
 - Drive train technology not used in later U.S. nuclear subs.
- *USS Glenard P. Lipscomb (SSN-685)*:
 - One ship class based on Sturgeon-class hull. 2nd-generation turbo-electric drive.
 - Turbo-electric drive technology demonstrated relatively low reliability.
 - Not used (yet) in later U.S. nuclear subs

New technologies tested on one-of-a-kind operational SSNs

- *USS Narwhal* (SSN-671):
 - One ship class. 1st natural circulation reactor (S5G) rated @ 90 MWt, with small main coolant pumps used only for high-power operation.
 - Reactor technology employed in S8G for Ohio-class SSBN
 - Reactor refueled twice during *Narwhal's* 30-year operational career.
 - Larger hull diameter than Sturgeon-class (33 ft. vs. 31.6 ft.); interior layout provided better accessibility than earlier boats.
 - Directly-coupled, single main turbine (no reduction gear)
 - 1st (and maybe only) U.S. use of scoop seawater injection for cooling water (as in several Russian subs)
 - Quietest U.S. sub until Ohio-class SSBNs and Seawolf-class SSNs

Los Angeles (688)-class SSN

Source: usnavymuseum.org



- 62 Los Angeles-class boats constitute the largest class of U.S. nuclear submarines.
- Built by two different contractors, General Dynamics Electric Boat Division and Newport News Shipbuilding Co., and commissioned in a 20-year period from 1976 – 1996
- Three variants:
 - Flight I (31 boats):
 - Relative to Sturgeon (637)-class: Faster, quieter, improved weapons system, larger diameter hull, not as deep diving.
 - Flight II (8 boats):
 - Added 12 x Vertical Launch System (VLS) launchers in bow, outside the pressure hull
 - Improved D2W reactor core
 - Improved 688i (23 boats):
 - Same as Flight II: 12 x VLS launchers in the bow; D2W reactor core;
 - Improved sonar: BSY-1; designed for under-ice operation.
 - Relocated forward diving planes from the sail to the hull for simpler under ice operations

Los Angeles (688) class SSN

- Propulsion:

- 688 Flight I boats: 1 x S6G reactor plant with a D1G-2 reactor core rated @ 150 MWt; 2 x main steam turbines delivering a combined 30,000 shaft horsepower to a single propeller.
 - D1G-2 core, replaced with D2W core during mid-life refueling.
- 688 Flight II and 688i boats: 1 x S6G reactor plant with a D2W reactor core rated @ 165 MWt; 2 x main steam turbines delivering a combined 33,500 shp (est) to a single propeller.

- Armament:

- 4 x 533 mm (21 inch) mid-ship torpedo tubes; storage for 21 weapons: Mk-48 torpedo, SUBROC anti-submarine missile; Harpoon anti-ship cruise missiles, or Tomahawk land attack cruise missile; also Mark 60 CAPTOR or Mark 67 mines

- Operational matters:

- 19 Jan 1991: *USS Louisville* (SSN-724) fired the 1st submarine launched Tomahawk cruise missiles in combat during *Operation Desert Storm*, after a 14,000 mile transit from San Diego.
- January 2005: *USS San Francisco* (SSN-711) collided with a seamount while transiting at high speed and moderate depth in the Pacific.
- 14 Flight I boats were decommissioned early after their mid-life reactor refuelings were cancelled.
- 2012: While in Portsmouth Naval Shipyard, 688i-class *USS Miami* (SSN-755) was severely damaged by an arson fire in the forward part of the boat. The ship was decommissioned in 2014.

Comparison: Los Angeles & Akula SSNs

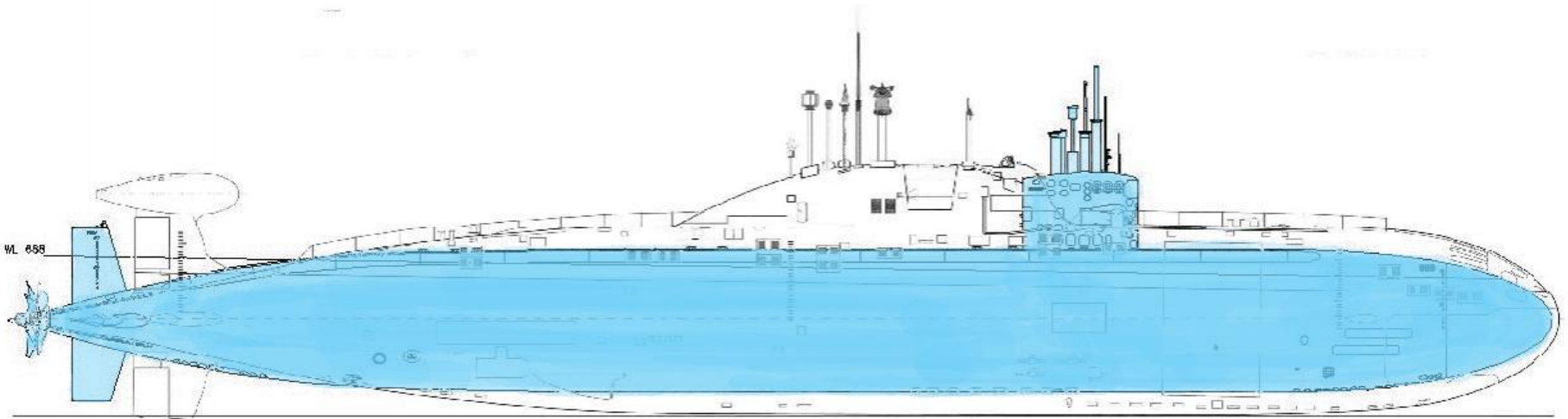

Source: adapted from <http://forum.sub-driver.com/forum/>

USS San Francisco (SSN-711) collision with a seamount in the Pacific

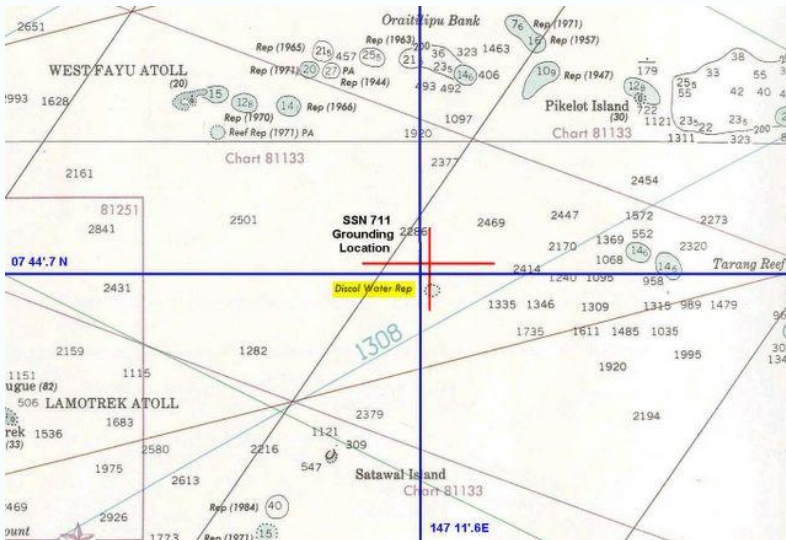

Source: lubbers-line.blogspot.com

- 8 Jan 2005: While transiting at flank (maximum) speed and submerged to 525 feet, Los Angeles Flight I-class SSN *San Francisco* hit a seamount in the Pacific that did not appear on the chart being used for navigation. However, other charts in *San Francisco's* possession displayed a navigation hazard in the vicinity of the grounding.
- One crewman was killed. The sub recovered from the collision and was able to return to port.
- *USS San Francisco* was repaired and continues in service as of mid 2015.



Source: <https://www.flickr.com/photos/tth91722/3539664246>

Los Angeles (688i)-class SSN

Internal arrangement

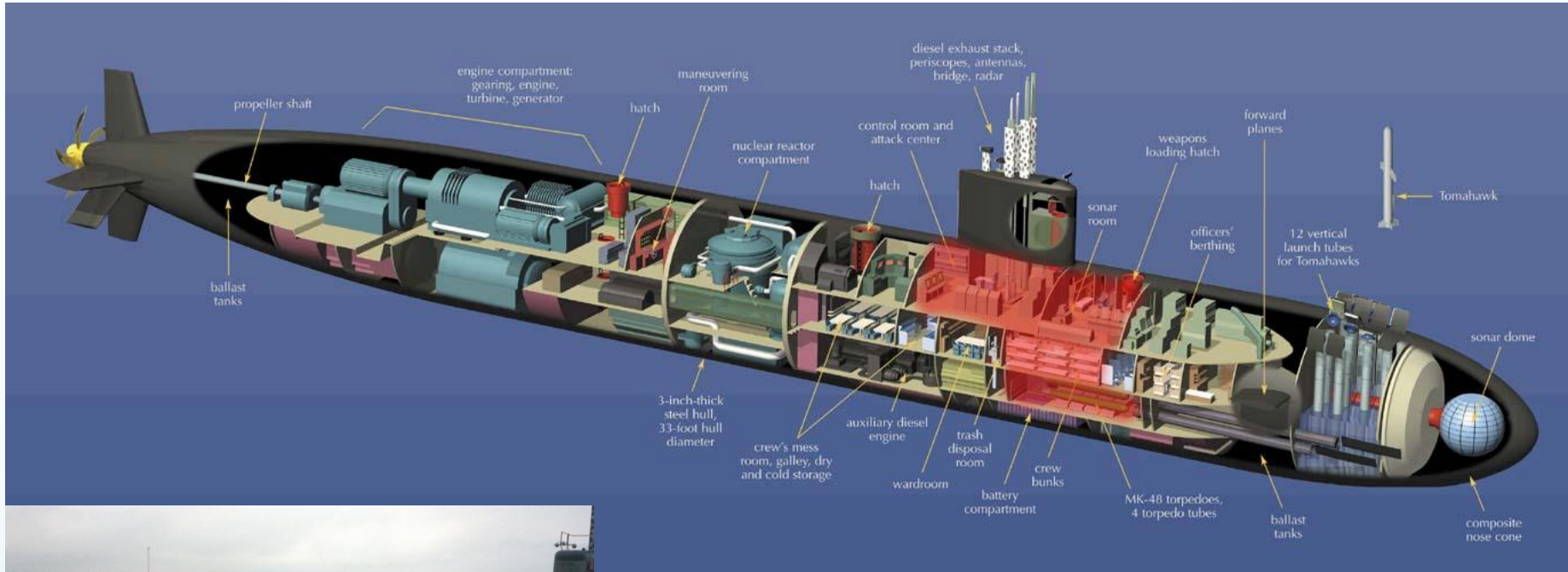

Source: <http://www.ussslierproject.com/tags/uss-miami-fire/>



Source: <https://en.wikipedia.org>

- 12 x VLS tubes in the bow, outside the pressure hull, for Tomahawk land-attack cruise missiles.
- Capable of carrying a Dry Deck Shelter on the top deck, behind the sail, for special operations forces and their equipment.

Seawolf (SSN-21)-class SSN

Source: www.shipbucket.com



- Designed to operate autonomously against the world's most capable submarine and surface threats. The primary mission was to destroy Soviet SSBNs before they could attack U.S. targets.
- Originally, 29 Seawolf-class subs were planned. Only 3 were built, primarily due to high program cost and dissolution of the USSR.
- Important design features:
 - 1st U.S. attack submarine with a hull made of high-strength HY-100 steel.
 - Larger diameter hull is completely coated with anechoic material to help reduce ship's noise signature.
 - Strengthened sail, designed to permit operations under the polar ice cap.
 - Pump-jet propulsor.
 - Extremely quiet at all speeds. Tactical speed (the speed at which a submarine is still quiet enough to remain undetected while tracking enemy submarines effectively) is rumored to be as high as 25 kts.

Seawolf (SSN-21)-class SSN

- Powerplant: 1 x S6W reactor rated @ 270 MWt (est); 2 x steam turbines delivering a combined 52,000 shaft horsepower (38.8 MW) to a single pump-jet propulsor.
- Weapons:
 - 8 x 660 mm (26 in) mid-ship torpedo tubes arranged on two decks
 - 50 missiles / torpedoes are carried, including Mk 48 ADCAP torpedoes, Harpoon anti-ship cruise missiles, Tomahawk land-attack cruise missiles; also Mark 60 CAPTOR or Mark 67 mines
 - No separate VLS cells for cruise missiles
- Special-operations force capabilities:
 - Dry Deck Shelter (DDS): can be attached to the top deck of the sub and used to store and launch a swimmer delivery vehicle and combat swimmers
 - Combat Swimmer Silo: an internal lock-out chamber that will deploy up to eight combat swimmers and their equipment at one time.
- Operational matters:
 - One boat, *USS Jimmy Carter* (SSN-23), received a 100 ft hull extension containing a “Multi-Mission Platform” (MMP) to support.

Seawolf (SSN-21)-class SSN

USS Conneticut (SSN-22)



Source, two photos: <http://www.seaforces.org/usnships/>

USS Seawolf (SSN-21)



Driving the Seawolf



Traditional helmsman, planesman, chief-of-the-watch and diving officer

Source: US Navy

Virginia-class SSN



Source: www.the-blueprints.com

- Designed as a multi-mission attack submarine, working independently or in consort with a battle group and other ships
- Design includes many innovations:
 - Emphasis on littoral (close-to-shore) operations; fly-by-wire ship control system improves shallow-water control.
 - Traditional periscopes replaced with two photonics masts that house HD color, black and white & infrared digital cameras on top of telescoping arms that do not penetrate the pressure hull.
 - Control room has been moved down one deck. This provides more room for an improved layout for better situational awareness.
 - Eliminates the traditional helmsman, planesman, chief of the watch and diving officer by combining them into two stations manned by two Chief Petty Officers.
 - Modular construction; open-architecture data system; greater use of commercial off-the-shelf equipment to enable simpler future upgrades
 - Improved support for special operation forces:
 - Torpedo room can be reconfigured to house a large number of special operation forces & equipment.
 - Large lock-in/lock-out chamber for divers; compatible with Dry Deck Shelters mounted to the deck.

Virginia-class SSN

- Powerplant: 1 x S9G reactor rated @ 210 MWt (est); secondary steam plant delivering a combined 40,000 shaft horsepower (29.8 MW) to a single pump-jet propulsor.
 - Expected service life is 33 years without refueling
- Armament:
 - 4 x 533 mm (21 inch) mid-ship torpedo tubes; storage for 27 torpedoes or missiles, including Mk-48 ADCAP torpedo, Harpoon anti-ship cruise missiles; also Mark 60 CAPTOR or Mark 67 mines
 - VLS tubes for Tomahawk land-attack cruise missiles
- Special-operations force capabilities:
 - Dry Deck Shelter (DDS): can be attached to the top deck of the sub and used to store and launch a swimmer delivery vehicle and combat swimmers
 - Internal lock-out chamber can deploy up to nine combat swimmers and equipment at one time.



Virginia-class SSN variants

- Block I: all commissioned
 - Weapons suite:
 - 4 x 533 mm (21 in) mid-ship torpedo tubes;
 - Mk 48 ADCAP torpedoes, Harpoon anti-ship cruise missiles, Mk 60 CAPTOR mines, advanced mobile mines
 - 12 x individual Vertical Launch System (VLS) cells for Tomahawk land-attack cruise missiles in the bow (similar to installations on Los Angeles-class Flight II and 688i boats)
 - Also can carry various Unmanned Underwater Vehicles (UUVs)
- Block II: all commissioned
 - Built in fewer, modular hull segments, saving \$500 m and 15 months constructing each boat
- Block III (started 2013): 2 of 8 commissioned by mid-2015
 - Weapons suite: The 12 individual VLS tubes on the bow are replaced by two Multiple All-up Round Canisters (MACs), each housing six tomahawk SLCMs.
 - Improved sonar: Large Aperture Bow Array

Blocks III & IV

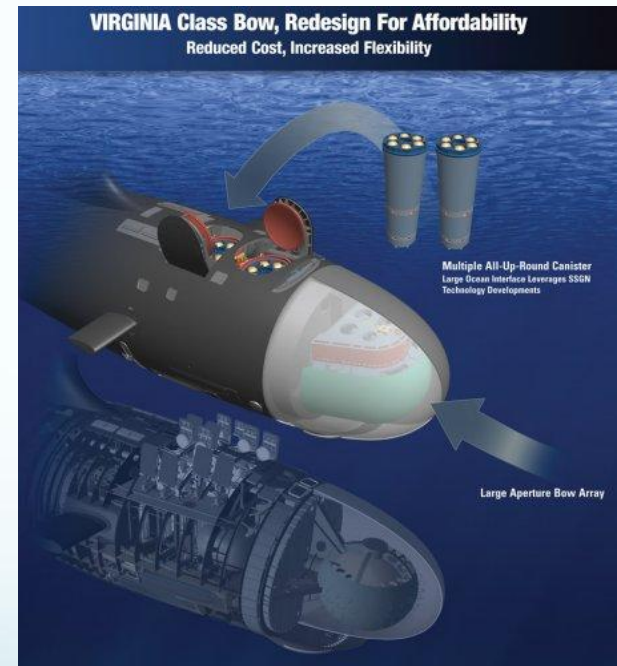

Source: NAVSEA

Virginia-class SSN variants

- Block IV (started 2014)
 - Equipment & system improvements to enable a reduction of major maintenance periods from 4 to 3 during the lifetime of the boat.
- Block V (expected start 2019):
 - Weapons suite:
 - 2 x bow MACs, each with six Tomahawk SLCMs or other weapons
 - Aft of the sail, a 70' section will be added to house four new vertical missile cells called Virginia Payload Modules (VPMs), each housing seven Tomahawk SLCMs or other weapons.
 - The design approved in October 2014 keeps the same 10.1 m (33 ft) diameter pressure hull and houses the machinery for the doors of the new MAC tubes in a small dorsal fairing.
 - Will replace Ohio-class SSGNs in late 2020s

Block V

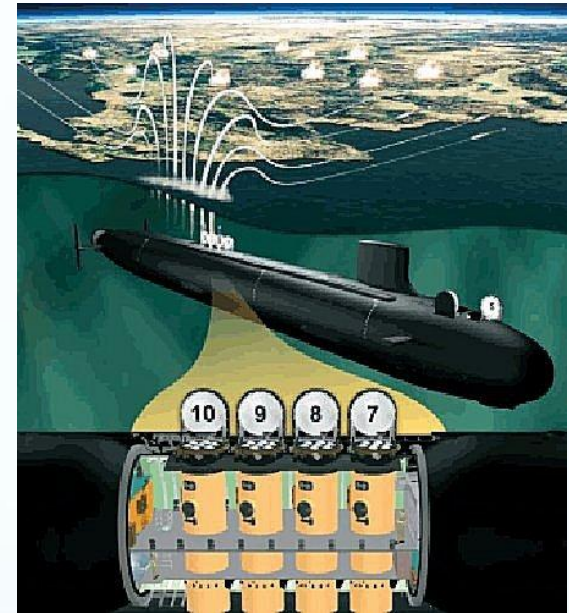

Source, two graphics: NAVSEA



Building a Virginia-class SSN

Work breakdown between Electric Boat & Newport News

Reactor compartment

Source: Newport News Shipbuilding

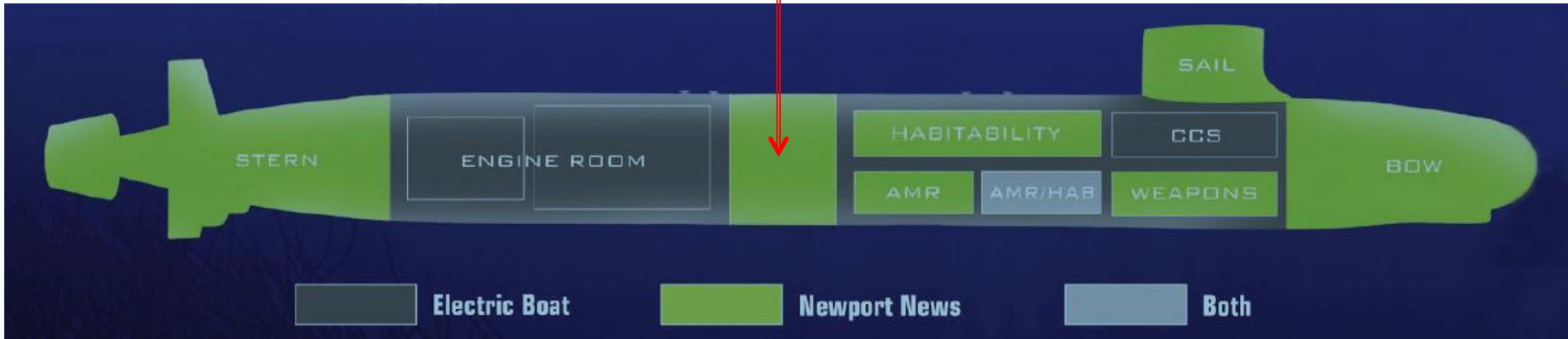

Notes:

CCS = Command & Control Center
AMR = Auxiliary Machinery Room



Source: <https://www.sinodefenceforum.com/>

Building a Virginia-class SSN

Installing an equipment raft in a hull section



Source: navylive.dodlive.mil

Building a Virginia-class SSN

Block I or II hull nearing completion

Pump-jet propulsor

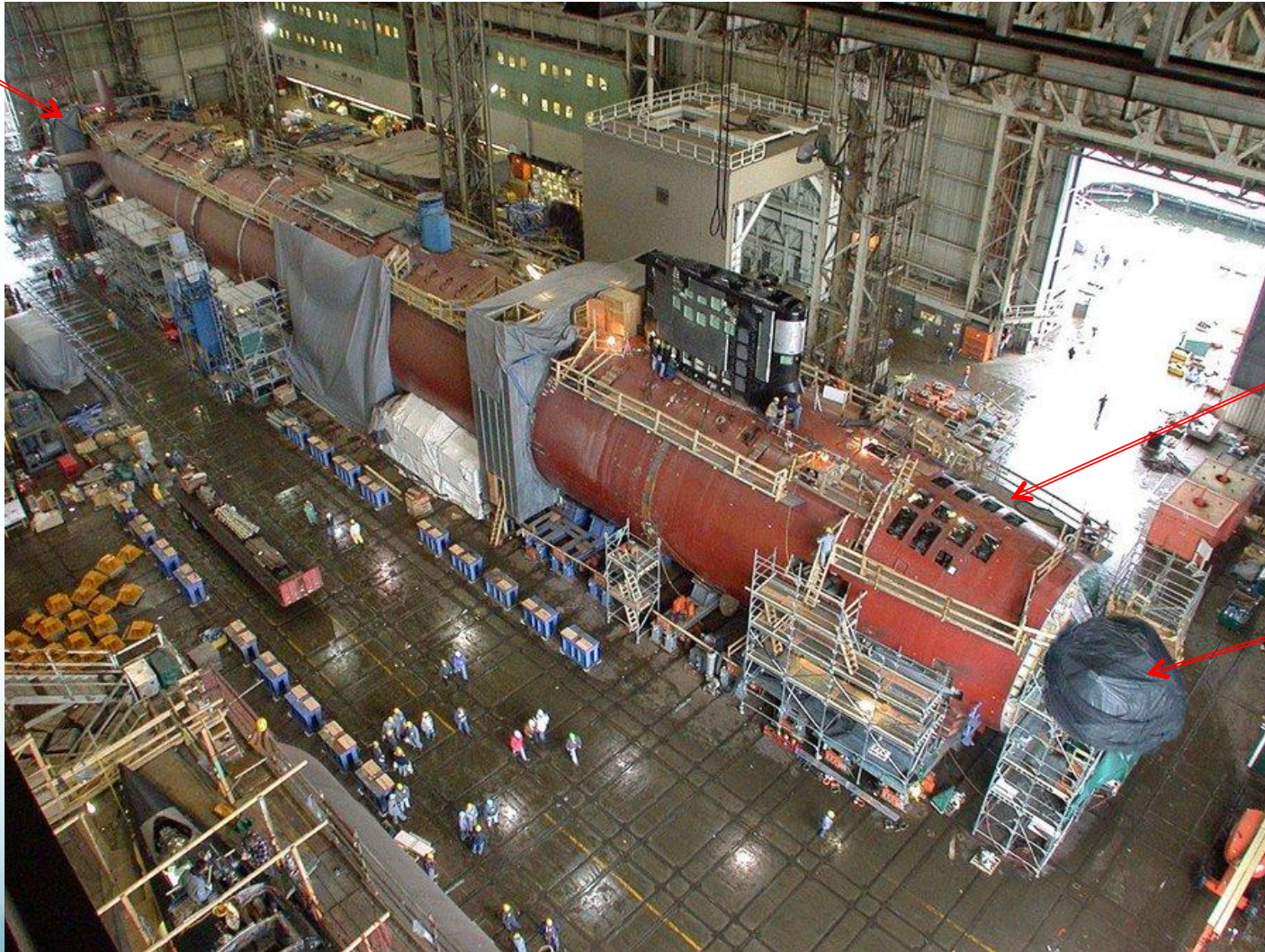

12 x VLS
missile
tubes

Sonar
spherical
array

Source: U.S. Navy

Large control room enabled by eliminating conventional periscope

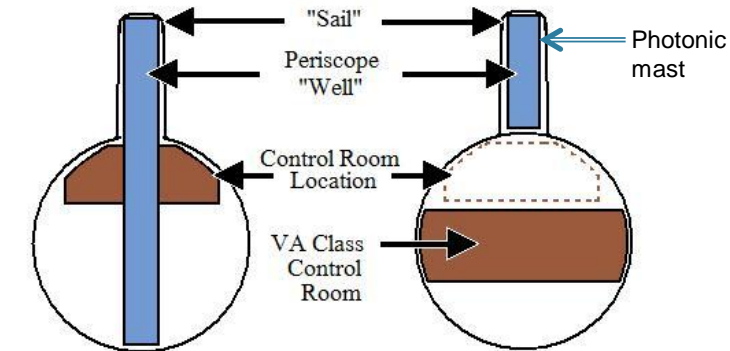

Pre-Virginia Class Submarine

Virginia Class Submarine



Source: Naval Submarine League San Diego



Source: U.S. Navy



Source: U.S. Navy

Driving a Virginia-class SSN



Eliminated the traditional helmsman, planesman, chief-of-the-watch and diving officer by combining them into two stations manned by two Chief Petty Officers

Source: U.S. Navy

Virginia-class SSN sonar arrays

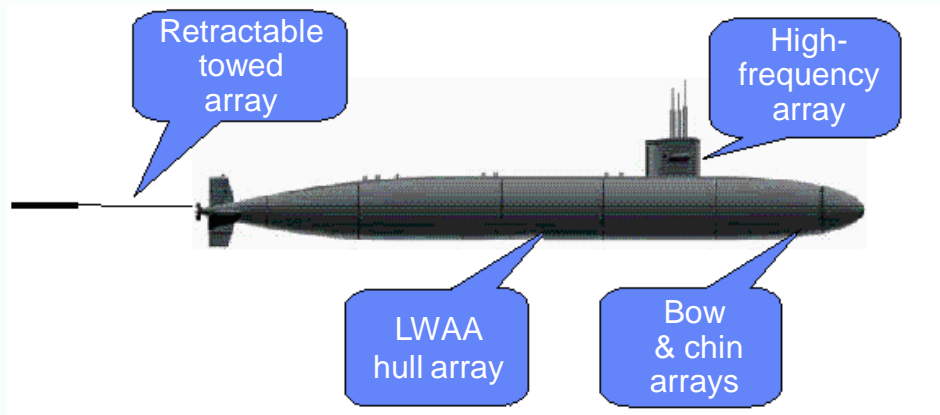

Bow spherical sonar array & "chin" array below



Source (above): adapted from <http://www.navy.mil/>



High-frequency sail array sonar for under-ice operations & mine detection

Conformal lightweight wide aperture array (LWAA)

<http://www.sqwestinc.com/>



<http://http://lubbers-line.blogspot.com/2005>

Universal Modular Mast (UMM) and the photonic sensor package



Source: U.S. Navy

- UUM telescopic hardware is entirely within the sail. The mast does not penetrate the submarines hull, like conventional periscopes.
- Replaces conventional periscopes on Virginia-class SSNs.



- Photonic sensor package provides HD color & thermal IR video cameras, laser rangefinder, ESM, communications & GPS functions.
- Big, but designed to reduce detectability.

Source: Naval Sea Systems Command



Source: L3 KEO

Unmanned Underwater Vehicles (UUV) capabilities



Source: Hydroid

- In July 2015, *USS North Dakota* (SSN-784), a Block III Virginia-class sub, returned to its base in Groton, CT after an almost two-month deployment to the Mediterranean Sea specifically to test a “free-flying” unmanned underwater vehicle (UUV) during military operations.
 - This was the first operational launch and recovery of this type of UUV during a military operation.
 - The drone deployed was a Remus 600, which is a 500-pound, 10-foot-long vehicle that its maker, Hydroid, says can be equipped with video cameras, GPS devices and sonar technology.
 - The Navy declined to say whether the Remus 600 was self-guided or piloted by a member of the submarine's crew.
 - The drone was launched from a Dry Deck Shelter (DDS) attached to the top of the Virginia class submarine.
- In the near future, submarine use of UUVs will become commonplace.

Comparison of the latest U.S. nuclear submarines

Seawolf & Virginia-class SSNs, Ohio-class SSBN / SSGN

Seawolf

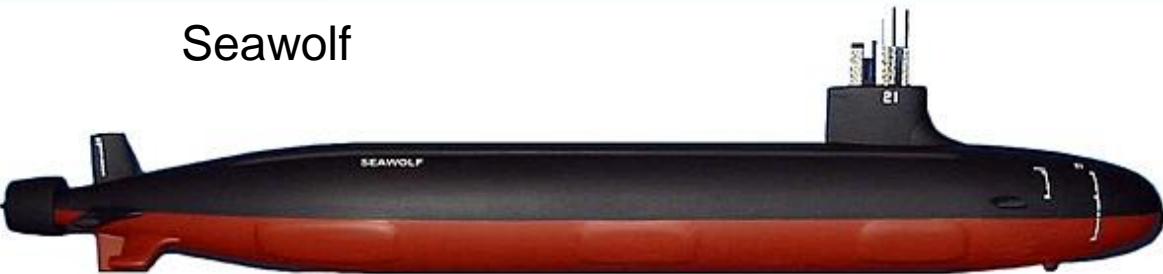

107.6 m (353 ft)

Virginia



114.8 m (377 ft)

Ohio



170.7 m (560 ft)

Source: adapted from <http://enrique262.tumblr.com>

**Strategic ballistic
missile submarines
(SSBN)**

Joint Army-Navy Ballistic Missile Committee

- 1948 “Key West Agreement” assigned nuclear warfare roles to U.S. military branches, including missile roles:
 - Air Force – ICBM
 - Army – IRBM
 - Navy – no defined ballistic missile role
- Summer 1955 – James Killian Jr. proposed that IRBMs also be sea-based. President Eisenhower agreed.
- 9 Sep 55: Joint program established to develop the Army’s liquid-fuelled Jupiter IRBM for Navy use on submarines & surface ships.
 - Shipboard hazard of liquid fuel recognized
- Feb 56: Parallel solid fuel IRBM study (Jupiter S) initiated with Lockheed

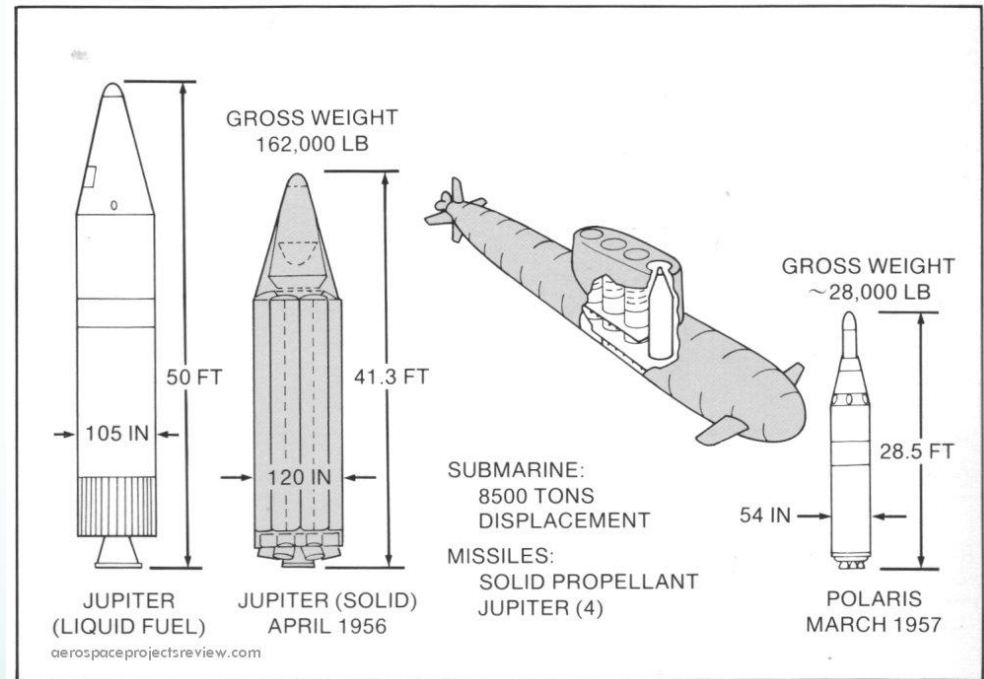

Source: Scott Lowther, Aerospace Project Review

Joint Army-Navy Ballistic Missile Committee

- Summer 1956: Project NABOSKA examined application of new technologies to the Navy IRBM:
 - Smaller nuclear warheads predicted (Edward Teller)
 - Smaller inertial guidance systems being developed (MIT Draper Labs)
 - Larger, higher specific impulse solid rocket motors demonstrated (Atlantic Research)
- Sep 56: AEC confirmed NABOSKA warhead predictions; Lockheed & Aerojet confirmed missile size & performance predictions.
- Sep 56: RADM William F. “Red” Raborn presented Lockheed’s “Polaris” missile design to Chief of Naval Operations (CNO), then to Secretary of Defense.
 - Recommended focus on submarine launch
- 8 Dec 56: Joint project terminated and the Navy was authorized to proceed with the Polaris program with concurrent development of required technologies.
- Polaris Mission: Missile system was designed as a second-strike weapon. Initial circular error probable (CEP) for the warhead was not small enough to use Polaris as a first-strike weapon.

Early Polaris missile sub concept

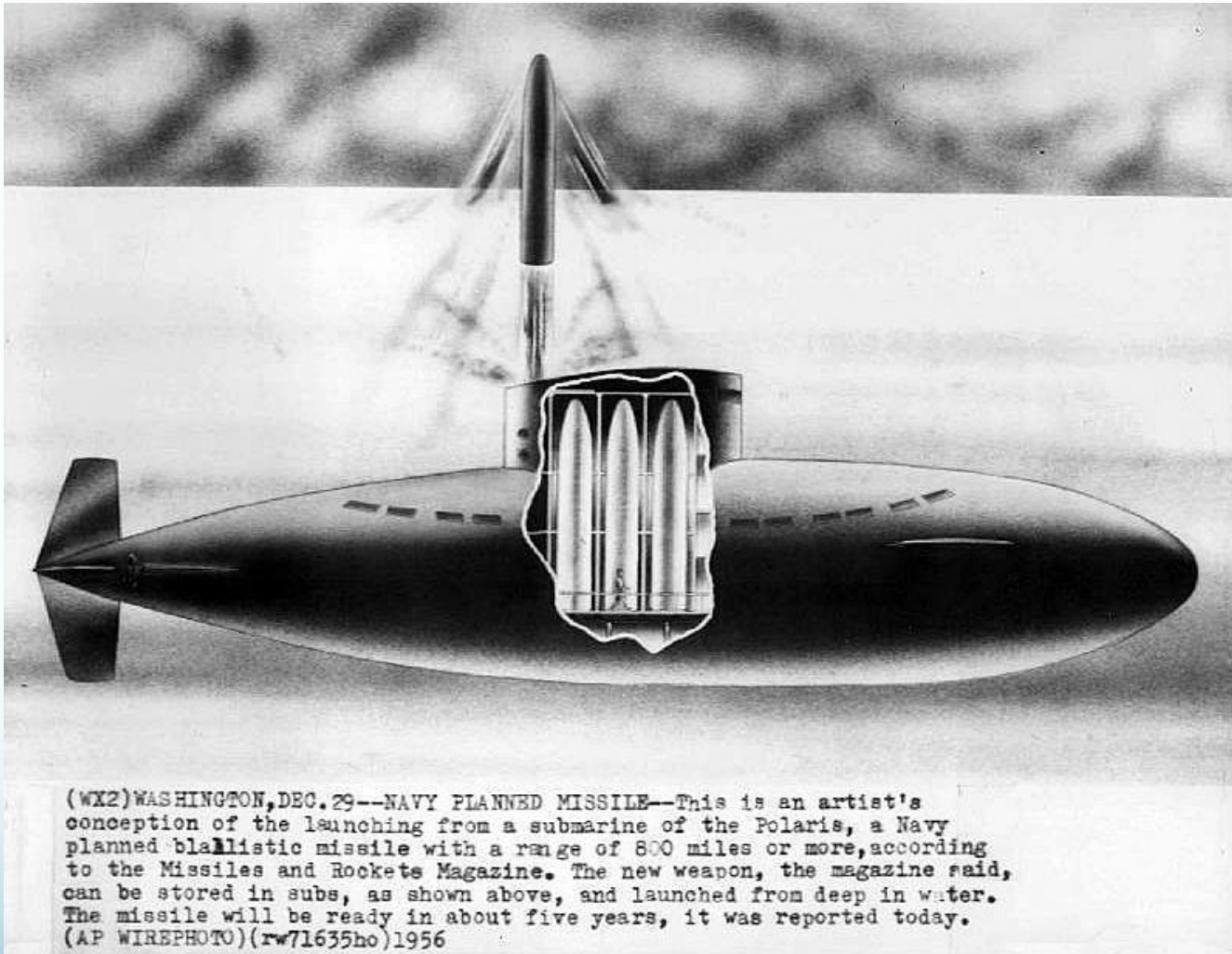

Navy news release, 29 Dec 1956

Source: Scott Lowther, Aerospace Project Review Blog

Polaris on surface ships

- *USS Observation Island* (E-AG-154) conducted the first at-sea test launch of a Polaris A1 missile on 27 August 1959.
- *USS Observation Island* continued serving as a test platform, launching the Polaris A2 in March 1961 and the A3 version in June 1963.
- Original Navy plans included installing Polaris on several U.S. cruisers.
- Creation of a NATO Multilateral Nuclear Force consisting of 25 surface ships with 200 Polaris missiles also was considered. The Italian cruiser *Giuseppe Garibaldi* was equipped with four Polaris launch tubes, but never received any missiles.
- Polaris was not deployed on any U.S. or NATO surface ship.

Launch from Observation Island



Source: U.S. Navy

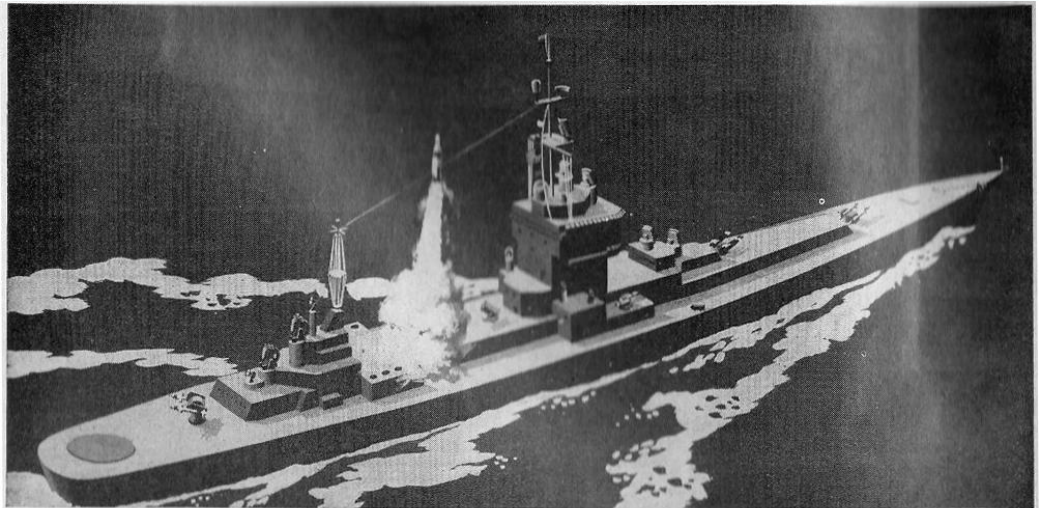

Long Beach with Polaris

SEABORNE POLARISES will be deployed aboard the nuclear powered Cruiser Long Beach—first of a possible fleet of

Polaris cruisers. The Long Beach will carry eight *Polarises* and other missiles. She will be operational in late 1963.

16

missiles and rockets, February 6, 1961

RADM William F. "Red" Raborn

- 8 Nov 1955: as Director of Special Projects at the Bureau of Weapons, tasked to develop a submarine-launched ballistic missile based on the Army's Jupiter IRBM.
 - Raborn was told the new system had to achieve interim capability by early 1963 and full capability by early 1965.
- 8 Dec 1956: Joint project terminated and Navy was authorized to proceed with Polaris program with concurrent development of required technologies.
- Raborn became the Polaris Program Manager. His team successfully coordinated the many concurrent development activities, each of which had to be successful in order to deliver the operational Polaris weapons system.
 - PERT (program evaluation and review technique) was a management tool used widely on the Polaris program
- The *USS George Washington* (SSBN-598), the 1st U.S nuclear-powered ballistic missile submarine, was commissioned 30 December 1959, fired its first test missile 20 July 1960, and departed on the Navy's first deterrent patrol on 15 November 1960, years ahead of the original program schedule.
- Raborn was awarded the Collier Trophy, presented by President Kennedy, for for his leadership on the Polaris program.



Source: U.S. Navy

Concurrent development of required technologies

- Submarine vehicle:
 - Hull: The first Polaris submarine, *USS George Washington* (SSBN-598), was created by cutting the hull of a new-construction SSN, *USS Scorpion* (SSN-589), and inserting a completely new center section with 16 missile launch tubes.
 - Nuclear power plant: The S5W nuclear propulsion section intended for *USS Scorpion* was used without change on *USS George Washington*.
- Command & control communications system:
 - Naval Research Laboratory (NRL) developed a VLF facsimile transmission system, known as “Bedrock”
 - Earliest demonstrations were in 1959 for *USS Skate’s* (SSN-578) voyage to the North Pole, and in 1960 for *USS Triton’s* (SSN-586) circumnavigation of the globe, February-May 1960.
 - This became the first system to provide reliable command and control communication from a single high-power transmitting station in the U.S. to continuously submerged submarines operating in any region of the world.
- Submarine navigation system:
 - Sperry developed the Mk II SINS (Ships Inertial Navigation System), which became the standard on all Polaris subs
 - First deployed in 1960 on *USS Halibut* and for *USS Seadragon’s* Arctic cruise.

Concurrent development of required technologies

- Small (enough) nuclear warhead: 600 kT W-47 Y1
 - Diameter: 18 in (46 cm); length: 47 in (120 cm) long; Weight: 717 lb (326 kg)
 - First nuclear warhead with a new, miniaturized pit
- Re-entry vehicle: Mark 1
 - Mk-1 RV had a beryllium heat-sink heat shield
- Missile system:
 - Polaris solid-fuel missile:
 - Lockheed Polaris A1 (UGM-27A) 2-stage missile airframe
 - Aerojet General solid rocket motors; Polyurethane Ammonium Perchlorate (PU/AP) solid fuel
 - Underwater launch system:
 - Naval Ordnance Test Station (now Space and Naval Warfare Systems Center Pacific) developed a “cold launch” method, where the missile is ejected from the vertical launch tube by high-pressure gas and the missile breaches the surface before the rocket motor ignites.
 - Westinghouse/MIT launch control system activated the high-pressure gas flow,
 - 4 April 1960: First live submerged test launch took place off San Clemente Island
 - Fire control system: General Electric Mark 80 analog / digital fire control system
 - Missile inertial navigation system:
 - Designed by MIT, manufactured by General Electric and Hughes

U.S fleet ballistic missile subs (SSBN)

Class	# in Class	Length	Beam	Displacement (tons)	Reactor	Shaft hp	Max speed (kts)	Years delivered	Years in service
George Washington (SSBN-598)	5	116.3 m (381.6 ft)	10.1 m (33 ft)	6,000 (surf), 6,880 (sub)	S5W	15,000	20+	Dec 59 - Mar 61	Dec 59 – May 84
Ethan Allen (SSBN-608)	5*	125.1 m (410.3 ft)	10.1 m (33 ft)	7,070 (surf), 8,010 (sub)	S5W	15,000	20+	Aug 61 - Jan 63	Mar 83 – Jul 92
Lafayette (SSBN-616)	9	129.5 m (425 ft)	10.1 m (33 ft)	7,370 (surf), 8,380 (sub)	S5W	15,000	20+	Apr 63 - Dec 64	Dec 86 – Feb 95
James Madison (SSBN-627)	10	129.5 m (425 ft)	10.1 m (33 ft)	7,440 (surf), 8,370 (sub)	S5W	15,000	20+	Apr 64 – Dec 64	Jul 64 - 1995
Benjamin Franklin (SSBN-640)	12*	129.5 m (425 ft)	10.1 m (33 ft)	7,250 (surf), 8,250 (sub)	S5W	15,000	20+	Oct 65 - Apr 67	Aug 92 – Jan 95***
Ohio (SSBN-726)	14**	170.7 m (560 ft)	12.8 m (42 ft)	15,275 (surf), 16,800 (sub)	S8G	60,000	20+	Nov 81 – Sep 97	Nov 81 - present

* Two in this class were converted to SSN role with special operations SEAL delivery capabilities

** Originally 18. Four converted in 2002 to a non-SSBN role to comply with START II treaty limit on number of SSBNs.

*** All were retired by 1995 except James K. Polk and Kamehameha, which were retained as special operations SSNs with 2 x Dry Deck Shelters on the missile deck.

Initial Operating Capability (IOC) dates for U.S. SLBMs and SSBNs

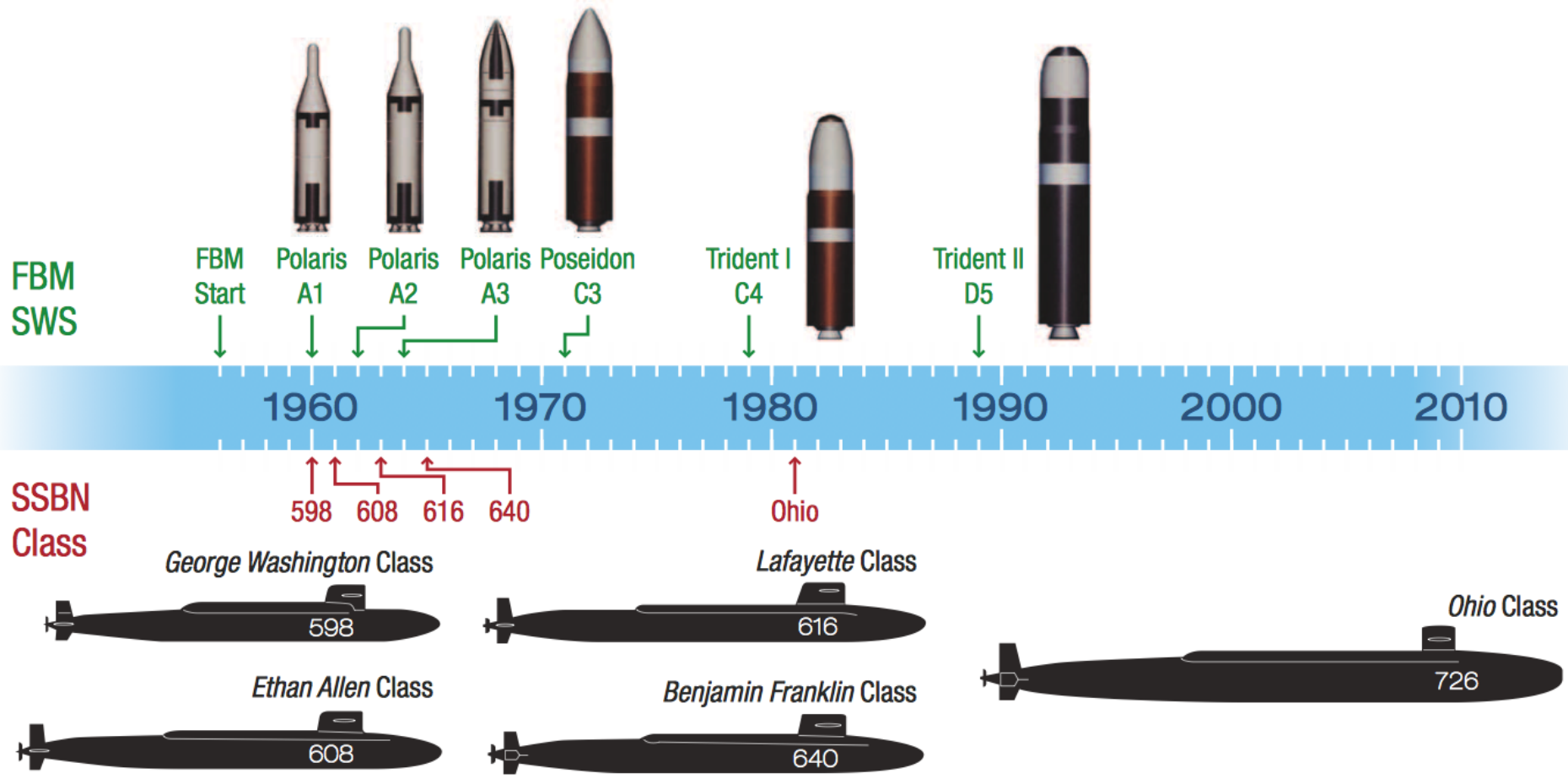

Evolution of U.S. submarine-launched ballistic missiles (SLBMs)

1955
INITIAL
CONCEPT

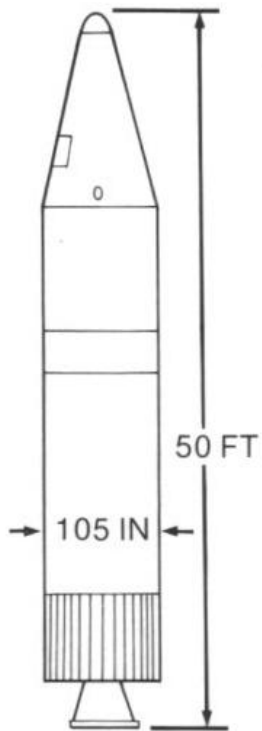

JUPITER
(LIQUID FUEL)

TRIDENT I & II

POLARIS A1, A2, A3

POSEIDO
N

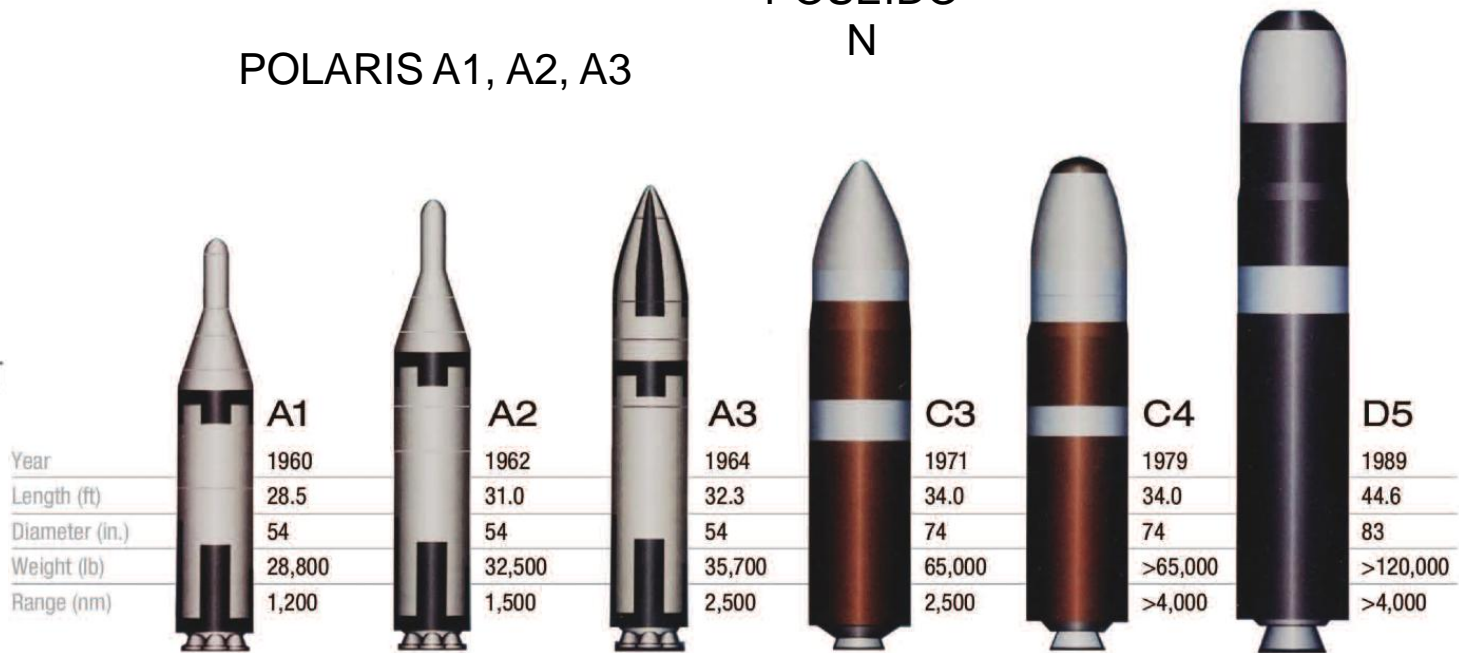

Source: JOHNS HOPKINS APL TECHNICAL DIGEST, VOLUME 29, NUMBER 4 (2011)

Comparison of U.S. submarine-launched ballistic missiles (SLBMs)

SLBM	Years in service	Weight	Length	Diameter	# of stages	Range / Guidance	Warhead
Polaris A1 (UGM-27A)	Nov 1960 - Oct 1965	13,063 kg (28,800 lb)	8.69 m (28.5 ft)	1.37 m (54 in)	2 (solid)	1,931 km (1,200 mi) / inertial	1 x W-47 @ 600 kt
Polaris A2 (UGM-27B)	Jun 1962 - Sep 1974	14,742 kg (32,500 lb)	9.45 m (31.0 ft)	1.37 m (54 in)	2 (solid)	2,414 km (1,500 mi) / inertial	1 x W-47-Y1 @ 600 kt, upgraded to 1 x W-47-Y2 @ 1 MT
Polaris A3 (UGM-27C)	Sep 1964 - Feb 1982	16,193 kg (35,700 lb)	9.45 m (31.0 ft)	1.37 m (54 in)	2 (solid)	4,023 km (2,500 mi) /inertial	Initially 1 x W-47 @ 500 kt, upgraded to Mk 2 RV cluster, 3 x W58 @ 200 kt
Poseidon C3 (UGM-73A)	Mar 1971 - 1992	29,484 kg (65,000 lb)	10.35 m (34.0 ft)	1.88 m (74 in)	2 (solid)	4,023 km (2,500 mi)/ inertial	Mk 3 MIRV, Typ 10 to 14 x W68 @ 50 kt
Trident C4 (UGM-96, Trident I)	Oct 1979 - Sep 2005	33,112 kg (73,000 lb)	10.35 m (34.0 ft)	1.88 m (74 in)	3 (solid)	> 6,437 km (4,000 mi)/ stellar inertial	Mk 4 MIRV Typ 7 x W76 @ 100 kt
Trident D5 (UGM-133, Trident II)	1989 - present	58,967 kg (130,000 lb)	13.59 m (44.6 ft)	2.11 m (83 in)	3 (solid)	> 6,437 km (4,000 mi)/ stellar inertial	Mk 4 MIRV, Typ 7 x W76 @ 100 kt, or Mk 5 MIRV, Typ 7 x W88 @ 475 kt

U.S. SLBM chronology

- Polaris A1 (UGM-27A)

- Carried operationally only aboard the George Washington-class SSBNs.
- CEP: about 2 miles
- 27 August 1959: *USS Observation Island* (E-AG-154) conducted the first at-sea test launch of a Polaris A1 missile.
- 4 April 1960: First live submerged test launch took place off San Clemente Island
- 20 July 1960: The first submerged launch of a Polaris A1 missile from a submarine occurred. *USS George Washington* launched two Polaris A1 missiles off the coast of Cape Canaveral.
- 15 November 1960: Carrying 16 Polaris A1 missiles, *USS George Washington* started the first operational FBM patrol. The submarine completed her first patrol after 66 days of submerged running on 21 January 1961.
- Replaced by Polaris A3.

- Polaris A2 (UGM-27B)

- Initially carried aboard all five Ethan Allen Class submarines, which were the first of the FBM submarines to be built from scratch as SSBNs.
- CEP: about 2 miles
- 6 May 1962: A Polaris A2 missile held the distinction of being the only strategic missile ever to carry a live nuclear warhead to its target. In the only test of its kind, a Polaris A2 launched from *USS Ethan Allen* (SSBN-608) carried a live W-47Y1 nuclear warhead to a target area near Christmas Island.
- Replaced by Polaris A3.

Operation Dominic

Shot Frigate-Bird, 6 May 1962

- Frigate Bird was the only U.S. test of an operational strategic ballistic missile with a live nuclear warhead.
- This test involved firing a Polaris A2 SLBM from the submerged FBM submarine *USS Ethan Allen* (SSBN-608) toward a target area near Christmas Island (Kiritimati).
- The Polaris A2 SLBM was armed with a W-47Y1 warhead in a Mk-1 re-entry vehicle (RV).
 - The Mk-1 RV had a beryllium heat-sink heat shield, and with the 717 lb. warhead, had a gross weight of 900 lb.
 - The warhead had a yield of 600 kt, for a yield-to-weight ratio of 1.84 kT/kg
- The warhead and RV flew 1,020 nm downrange toward Christmas Island before re-entering the atmosphere 12.5 minutes after launch, and detonating in an airburst at 11,000 feet.
 - The missile/RV demonstrated an accuracy on the order of 2,200 yards (about 1.25 mile), which was within the Polaris A2 circular error probable (CEP) of 2 miles.



Source: www.nuclearweaponarchive.org

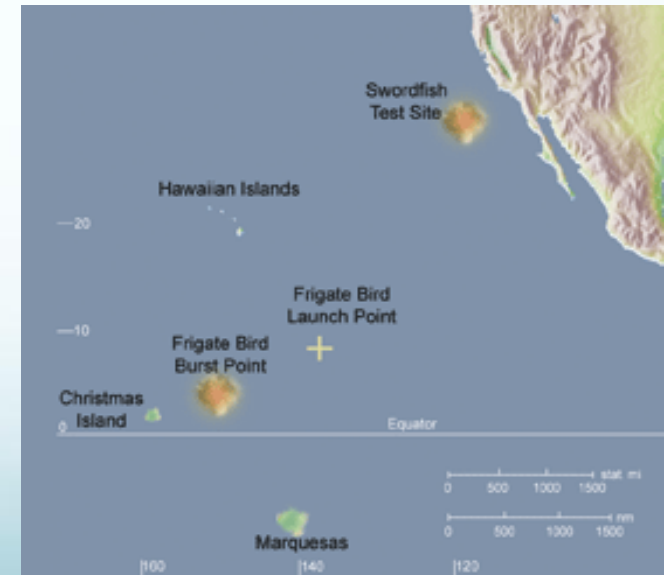

Source: www.navy.mil

U.S. SLBM chronology

- Polaris A3 (UGM-27C)
 - First Polaris with a multiple reentry vehicle warhead (3 x Mk 2 RVs with 200 kt W-58 warhead).
 - CEP: about 3,000 feet (910 m)
 - 28 Sep 1964: *USS Daniel Webster* (SSBN-626) made the 1st deterrent patrol with Polaris A3
 - Replaced by Poseidon.
- Poseidon C3 (UGM-73A, originally Polaris B3)
 - First U.S. SLBM with multiple, independently-targetable reentry vehicles (MIRV).
 - Could carry 10 – 14 reentry vehicles per warhead.
 - Carrying 14 RVs reduced the missile's range to that of the Polaris A3. For this reason, missiles typically employed 10 RVs per warhead.
 - CEP: about 1,800 feet (550 m)
 - 16 Aug 1968: 1st test launch from a flat pad at Cape Canaveral, Florida
 - 3 Aug 1970: 1st submerged launch, *USS James Madison* (SSBN 627)
 - 31 Mar 1971: Poseidon declared operational and eventually was deployed aboard all 31 Lafayette-class, James Madison-class & Ben Franklin-class SSBNs.
 - Replaced by Trident I

U.S. SLBM chronology

• Trident I (C4, UGM-96A)

- Trident I was based on the Poseidon missile and was designed to be retrofitted to existing Poseidon submarines and deployed on the new Ohio-class (SSBN-726) subs.
- Trident I introduced the “aerospike,” which deployed on launch at the nose of the missile and significantly reduced drag. It is estimated to have increased the missile’s range by 550 km.
- CEP: about 1,250 feet (380 m)
- January 1977: First Trident I test launch from a flat pad at Cape Canaveral
- October 1979: First deployed at sea on *USS Francis Scott Key* (SSBN 657).
- February 1995: *USS Florida* (SSBN-728) launched a test salvo of 6 Trident missiles in rapid succession.
- Trident I was the last SLBM to use the Ships Inertial Navigation System (SINS)
- Retired Sep 2005, replaced by Trident II.

• Trident II (D5, UGM-133)

- Deployed on U.S. Ohio-class and UK Vanguard-class SSBNs
- CEP: about 300–390 feet (90-120 m)
- January 1987: 1st Trident II test launch from a flat pad at Cape Canaveral
- March 1990: Trident II Initial Operating Capability (IOC)
- It is estimated that 540 Trident II missiles have been built for U.S. and UK SSBNs
- The Trident D5LE (life-extension) version is expected to remain in service until 2042.



Source:
[https://en.wikipedia.org/wiki/Trident_\(missile\)](https://en.wikipedia.org/wiki/Trident_(missile))

Fitting an SLBM into a submarine hull

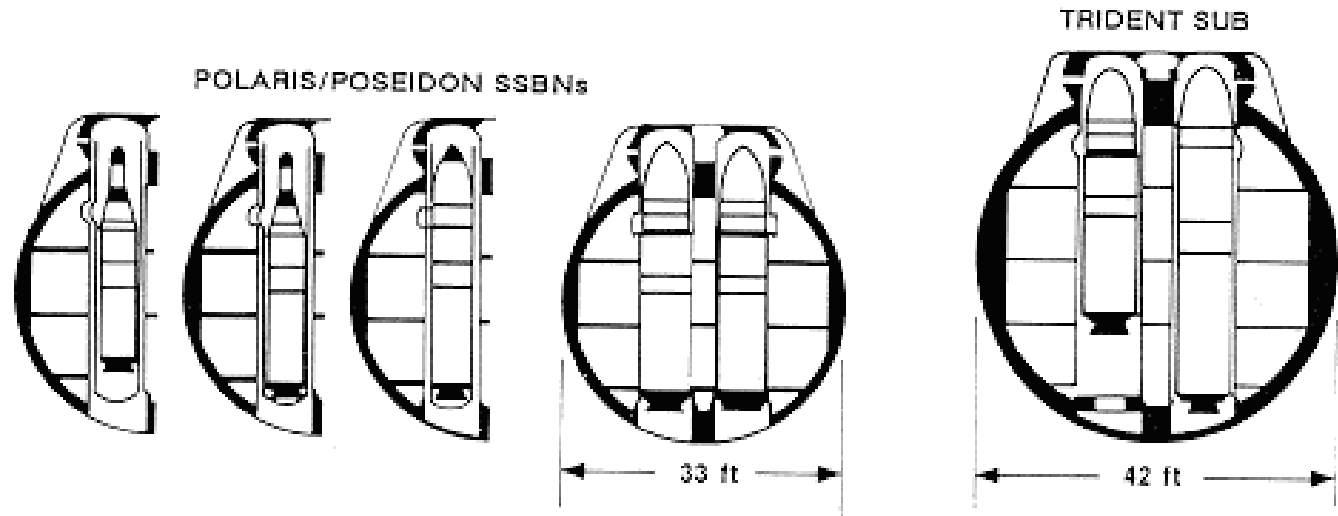

	<u>A1</u>	<u>A2</u>	<u>A3</u>	<u>C3</u>	<u>C4</u>	<u>C4</u>	<u>D5</u>
DATE DEPLOYED	1960	1962	1964	1971	1979	1979	1989
RANGE (nm)	1200	1500	2500	2500	4000	4000	>4000
LENGTH (ft)	28.5	31.0	32.3	34.1		34.1	44.6
DIAMETER (in.)	54	54	54	74		74	83
WEIGHT (lb)	28,000	32,500	35,700	64,000/73,000		73,000	~130,000

FBM Constraints and Growth

Polaris/Poseidon SSBN

Internal arrangement

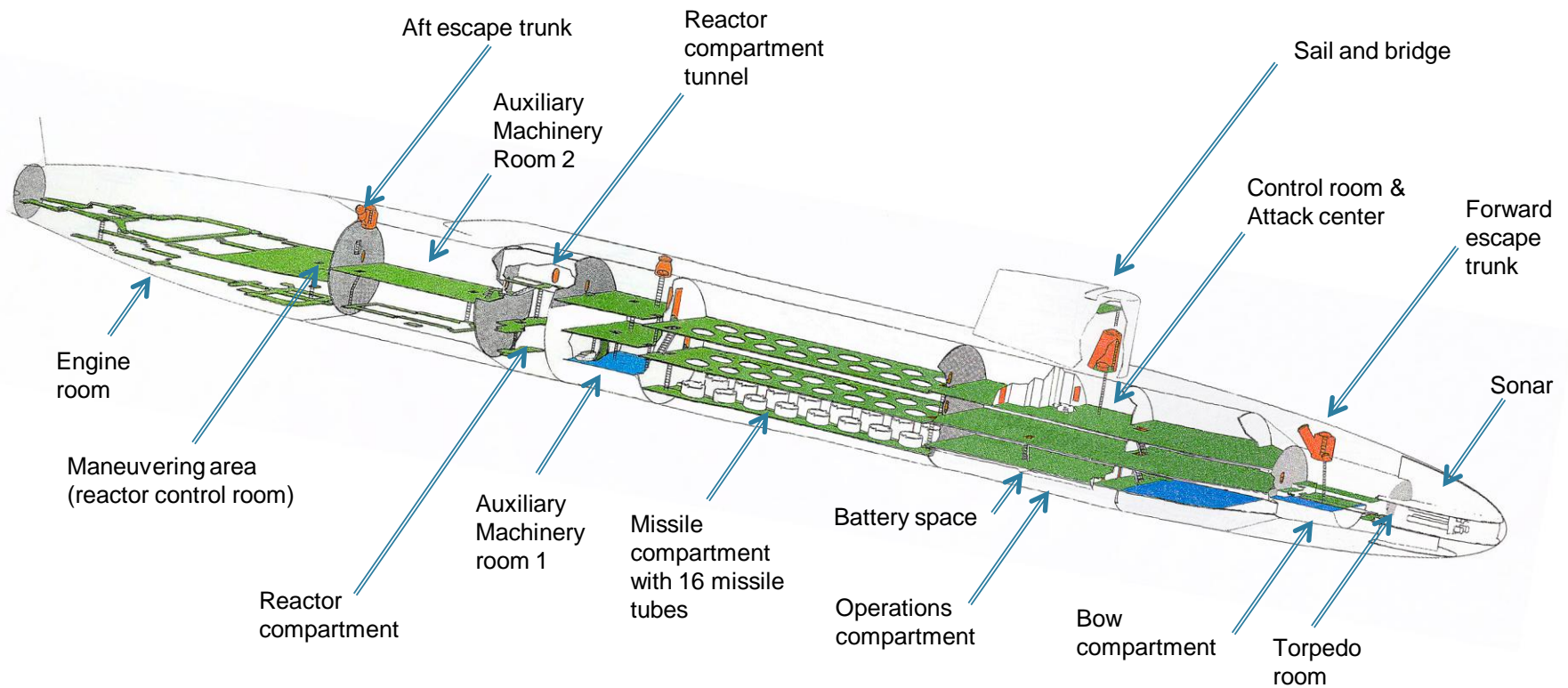

Source: adapted from U.S. Navy

Polaris/Trident SSBN

George Washington (SSBN-598)-class

- Five boats in this class. First two boats in class originally were started as Skipjack-class SSNs (*Scorpion* & *Sculpin*), but were modified during construction with the insertion of a 130 ft (40 m) ballistic missile section to accelerate SSBN delivery.
- 15 Nov 1960: *USS George Washington* (SSBN-598) started the 1st Polaris nuclear deterrent patrol armed with 16 Polaris A-1 ballistic missiles, 3 years 11 months after the Polaris FBM program was authorized by the Secretary of Defense.
- Each SSBN has two crews. A typical 105-day deployment cycle begins with a 3-day “turnover” with the prior crew. After taking over the boat, the new crew performs a 30-day refit and provisioning process assisted by the local tender or sub base, followed by a 70-day deterrent patrol.
- All subs in class were refitted to carry Polaris A-3 missiles.



USS George Washington (SSBN-598)

Source: www.navsource.org/archives

Polaris/Trident SSBN

Ethan Allen (SSBN-608)-class

- Five boats in this class. This is the first submarine class designed from the keel up as an SSBN.
- 23 October 1961: *USS Ethan Allen* (SSBN-608) made the 1st successful submerged launch of a Polaris A2
- 26 June 1962: *USS Ethan Allen* started its 1st deterrent patrol armed with Polaris A2.
- 6 May 1962: While submerged in the Pacific, *USS Ethan Allen*, (SSBN-608), operating as a unit of Joint Task Force 8 “Operation Frigate-Bird,” fired the only nuclear-armed Polaris missile ever launched

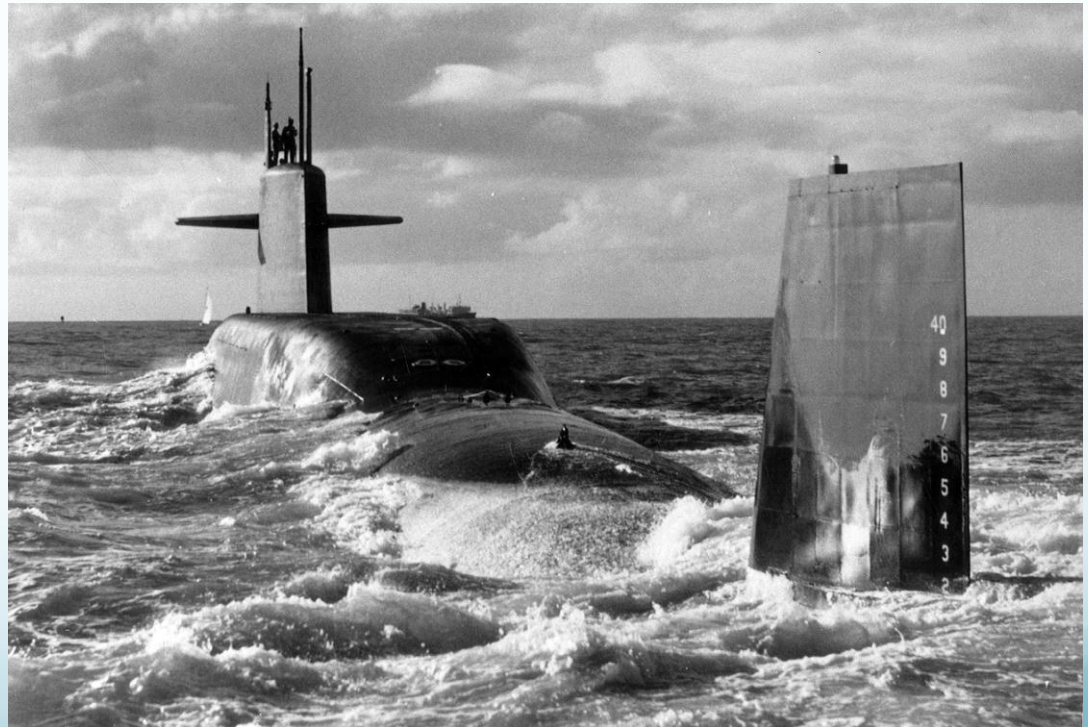

USS Thomas Jefferson (SSBN-618)

Source: www.navsourc.org/archives

Polaris/Trident SSBN

Lafayette (SSBN-616), James Madison (SSBN-627), and Ben Franklin (SSBN 640)-classes

- These three SSBN classes totalled 31 boats.
 - Lafayette class boats were outfitted initially with Polaris A2 missiles, except *USS Daniel Webster* (SSBN-626), which was the 1st equipped with Polaris A3.
 - James Madison-class boats are identical to Lafayette-class except that they were designed originally to carry Polaris A3.
 - Ben Franklin-class boats incorporated quieter machinery and other improvements
- The 2,500 nm range of the Polaris A3 extended FBM submarines operations to the Pacific Ocean, providing greater sea room and operating area to offset the expanding Soviet anti-submarine capabilities.
 - 25 December 1964: *USS Daniel Boone* (SSBN-629) departed Apra Harbor, Guam and began the 1st deterrent patrol with Polaris A3 in the Pacific.
- All of these SSBNs were modified to handle Poseidon C3 SLBM.
- Six James Madison-class and six Ben Franklin-class boats were modified again to handle Trident 1 SLBMs.

Ohio-class SSBN

Internal arrangement

The exhibition *Fast Attacks & Boomers: Submarines in the Cold War* opened in April 2000 at the National Museum of American History, Washington, D.C.

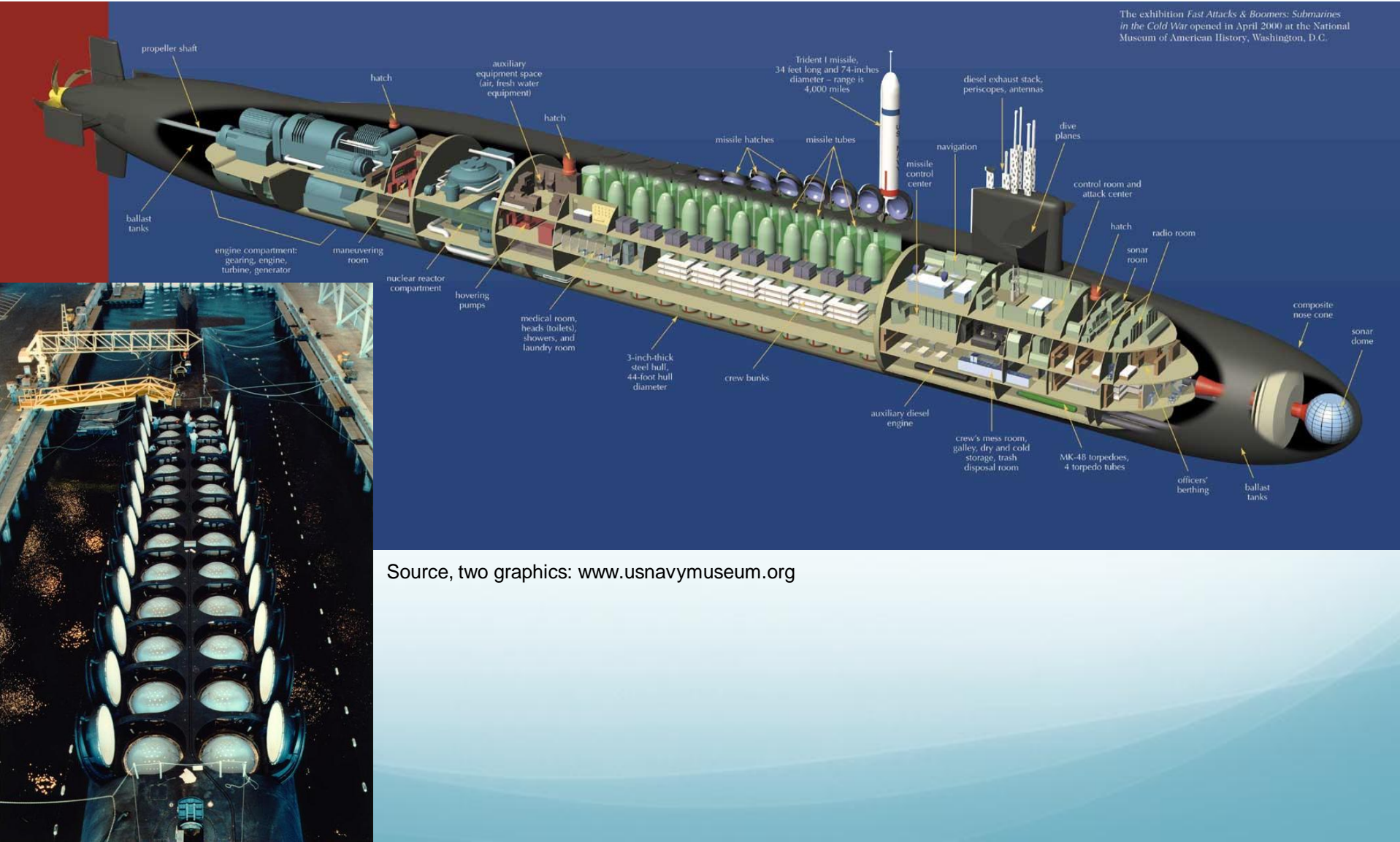

Source, two graphics: www.usnavymuseum.org

Ohio-class SSBN

- The 18 Ohio-class SSBNs are the largest subs ever built by the U.S.
 - The first eight Ohio-class submarines were armed initially with Trident I missiles. Each boat underwent a major overhaul to handle Trident II missiles.
 - Beginning with the 9th boat in class, *USS Tennessee* (SSBN-734), the remaining Ohio-class SSBNs were equipped originally to handle the larger Trident II.
 - In compliance with the 1992 Strategic Arms Reduction Treaty (START II), which limited the U.S. to 14 SSBNs starting in 2002, four Ohio-class subs were removed from SSBN duty and converted for the SSGN (cruise missile) role.
- The 14 remaining Ohio-class SSBNs each carry 24 Trident II missiles with approximately 50% of the total U.S. active inventory of strategic nuclear warheads.
- Propulsion:
 - 1 x S8G PWR rated at 312 MWt (est.), 2 x main steam turbines with a combined rating of 60,000 hp (45 MW) driving a single shaft.
 - Ohio-class subs require a mid-life refueling.
- Armament:
 - 24 x Trident II SLBMs in vertical launch tubes.
 - 4 x 533 mm (21") torpedo tubes for Mk-48 ADCAP torpedoes & Harpoon anti-ship cruise missiles

Ohio-class SSBN

- Navigation system:
 - The Trident I Ohio-class SSBNs were among the last U.S. subs to use the Ship Inertial Navigation System (SINS), which had been used since 1960 on all previous Polaris / Poseidon SSBNs.
 - For Trident II, major system changes include:
 - Adoption of the Electrostatically-Supported Gyro Navigator (ESGN) as the inertial navigator (replacing SINS)
 - Addition of the Navigation Sonar System (NSS) with increased capability to measure velocity
 - Adoption of Global Positioning System (GPS) to replace the aging Navy Navigation Satellite System (NAVSAT), and
 - Installation of a digital interface with the FBM weapon system and other ship systems.
- Operational matters:
 - Ohio-class SSBNs are among the very quietest nuclear subs operating today.
 - To decrease the time for replenishment, three large logistics hatches are fitted to provide large diameter resupply and repair openings
 - Typically four boats are on station ("hard alert") in designated patrol areas at any given time. Patrols last about 70 days.
 - New START treaty compliance:
 - By 5 Feb 2013, four Ohio-class submarines were converted permanently from SSBN to SSGN role, eliminating 96 strategic launchers.
 - In 2015 the U.S. Navy began reducing the number of missile tubes in Ohio-class SSBNs from 24 to 20 on each SSBN. This work will be completed by 5 Feb 2018, eliminating 40 strategic launchers.
 - Ohio-class SSBNs are expected start retiring in 2029, before the 1st Ohio-replacement sub is delivered to the fleet.

Ohio-class SSBN

scale comparison with Russian Typhoon-class SSBN

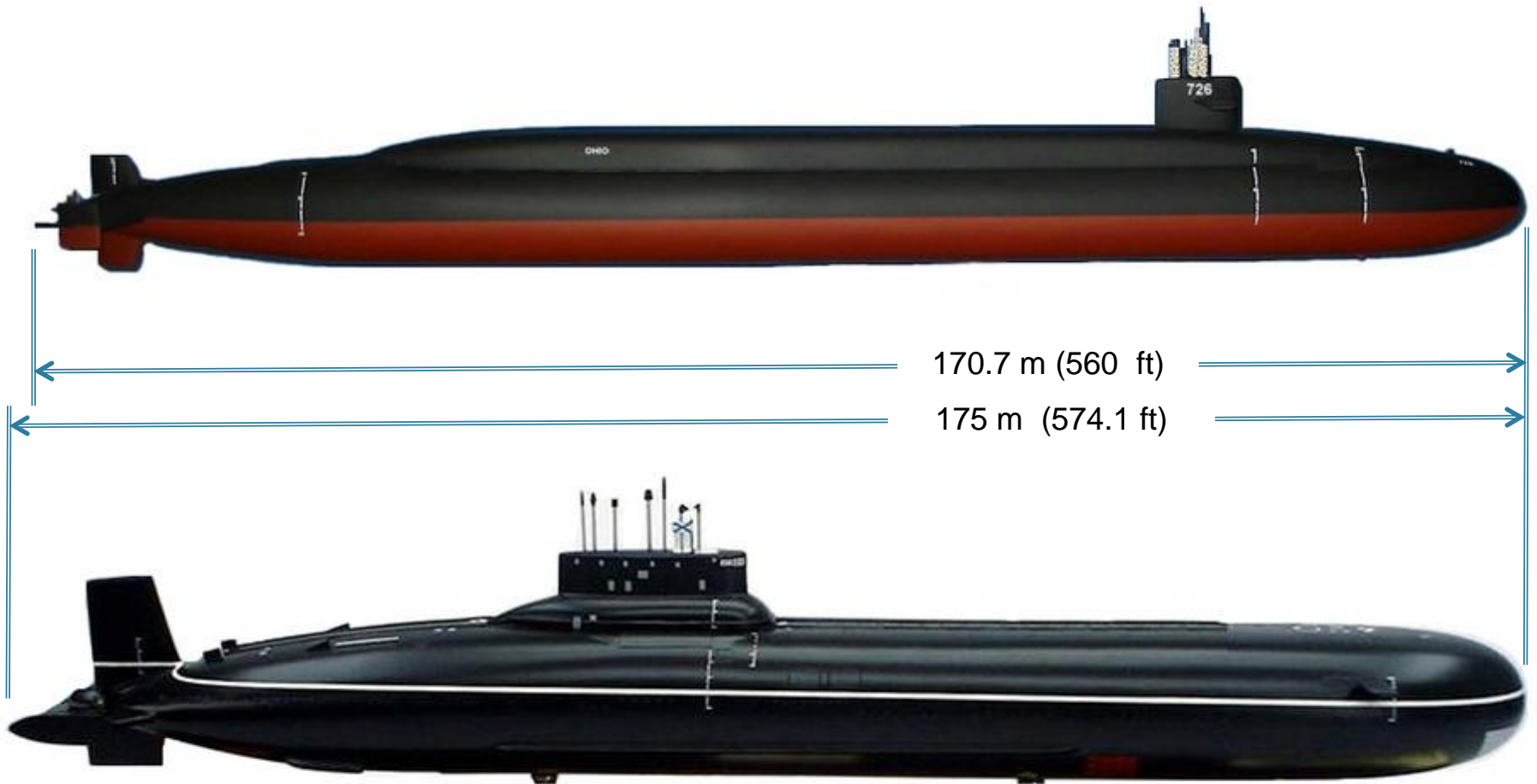

Driving an Ohio-class sub

USS Florida (SSBN/SSGN-728)



Traditional helmsman, planesman, chief-of-the-watch and diving officer

Source: US Navy

Trend in number of annual deterrent patrols by U.S. SSBNs



Source: fas.org/blogs/security/2009/03/usssbn/

Ohio-replacement SSBN

- The Navy plans to replace its current fleet of 14 Ohio-class SSBNs with 12 Ohio-Replacement SSBNs. Preliminary milestones for the 1st replacement sub include:
 - 2021: begin construction of the 1st boat
 - 2027: deliver to the Navy
 - 2031: ready to conduct 1st strategic deterrence patrol
- This program is being coordinated with the UK's Vanguard SSBN replacement (Royal Navy Successor submarine) program
 - Both U.S. and UK subs are expected to use a Common Missile Compartment (CMC). Work on the "quad-pack" modular missile tubes is well advanced.
 - Integrated tube and hull design. Each tube measures 86" (2.18 m) in diameter and 36' (10.97 m) in length and can accommodate a Trident II missile
- Other features of the Ohio-replacement are expected to include:
 - 42 year operational life
 - Life-of-the-ship reactor core (no refueling)
 - Likely 16 missile tubes instead of 24 on Ohio-class
 - Same 42' (13 m) beam of the Ohio-class subs
 - Electric drive, X-stern planes
- The "Submarine Shaftless Drive" (SDD) concept that the UK is planning for their Successor SSBN has been examined by the U.S. Navy, but there is no information on the choice of propulsor for the Ohio-replacement sub



CMC "quad-pack"

Source: General Dynamics

Ohio-replacement SSBN

OHIO Replacement: The US Navy's vision

The US Navy is developing its next generation SSBN with an eye towards cost reductions and an average price per boat of USD4.9 billion. Construction of the first hull is scheduled to start in 2019. The Ohio-class Replacement will leverage technologies from the Virginia-class SSNs as well as innovations that have been tested but never put onboard a production submarine.



- 1 X-stern:** Aligning aft control surfaces 45 degrees from the horizontal makes it more difficult for a submarine to inadvertently dive, allowing higher speed at greater depth.
- 2 Missile tubes:** The new SSBN will have four modular 87-inch diameter missile tube quad packs for 16 Trident II D5 SLBMs.
- 3 LAB array:** The Ohio Replacement will field a scaled-up version of the large aperture bow array designed for the Block III Virginias.
- 4 Hull coating:** The boat will use anechoic coatings developed for the Virginia class that reduce threats from hostile active sonar.
- 5 Electric drive:** An integrated power grid will drive the boat via permanent magnet induction motors, instead of a direct mechanical connection.
- 6 Virginia style propulsor:** A pump-jet reduces cavitation at higher speeds compared to propeller drives, and performs better in shallow water.

	OHIO	OHIO Replacement
HULL LENGTH	559 ft	TBD
HULL DIAMETER	42 ft	42 ft
MISSILE TUBES	24	16
SUBMERGED DISPLACEMENT	18,740 LT	19,737 LT

Cruise missile submarines (SSGN)

U.S cruise missile subs (SSGN)

Class	# in Class	Length	Beam	Displacement (tons)	Reactor	Shaft hp	Max speed	Years delivered	Years in service
Halibut – SSGN-575	1	106.7 m (350 ft)	8.8 m (29 ft)	3,655 (surf), 4,000 (sub)	S3W	7,300	20+	Jan 1960	1960 – 65 (as SSGN)
Ohio - SSGN conversion	4	170.7 m (560 ft)	12.8 m (42 ft)	16,764 (surf), 18,750 (sub)	S8G	60,000	20+	2002 - 04	2002 - present
Virginia SSGN (SSN-774 Block V)	TBD	136.2 m (447 ft)	10.1 m (33 ft)	Not known	S9G	40,000	25+	After 2020	

Comparison of U.S. submarine-launched cruise missiles

Cruise missile	Years in service	Weight	Length	Diam (D) /Span (S)	Speed (mph)	Range	Guidance	Warhead
Regulus I (SSM-N-8; RGM-6)	1955 – 1964 (withdrawn)	6,584 kg (14,515 lb)	9.8 m (32.17 ft)	S = 6.4 m (21 ft)	885 kph (550 mph) (M 0.9)	805 km (500 mi)	Radio command	Nuclear, W5 @ 40 kT (from 1955), W27 @ 2 MT (from 1958)
Regulus II (SSM-N-9)	Produced 1956 (not deployed)	10,433 kg (23,000 lb)	17.6 m (57.5 ft)	S = 6.1 m (20 ft)	M 2.0	1610 km (1,000 mi)	Inertial	Nuclear, W27 @ 2 MT
Harpoon Anti-ship (UGM-84A)	1977 - present	691 kg (1,523 lb) w/ booster	4.57 m (15 ft)	D = 0.53 m (21 in) S = 0.91 m (3.0 ft)	864 kph (537 mph)	130 km (81 mi)	Inertial + radar homing	Conventional, 488 lb
Tomahawk TLAM-N (BGM-109A)	1986 to 2010 – 13 (withdrawn)	1,315 kg (2,900 lb); 1,588 kg (3,500 lb) w/ booster	5.56 m (18.25 ft) ; 6.25 m (20.5 ft) w/booster	D = 0.53 m (21 in) S = 2.67 m (8.75 ft)	885 kph (550 mph) (est)	2,494 km (1,550 mi)	Inertial + TERCOM	Nuclear, W80-0 @ variable 5 – 150 kT
Tomahawk Anti-ship (UGM-109B)	1980s – early 1990s (wiithdrawn)	1,361 kg (3,000 lb) w/ booster	5.56 m (18.25 ft) ; 6.25 m (20.5 ft) w/booster	D = 0.53 m (21 in) S = 2.62 m (8.58 ft)	885 kph (550 mph) (est)	483 km (300 mi)	Inertial + radar homing	Conventional, 1,000 lb unitary
Tomahawk TLAM (UGM-109 C, D, E)	1983 - present	1,361 kg (3,000 lb) w/ booster	5.56 m (18.25 ft) ; 6.25 m (20.5 ft) w/booster	D = 0.53 m (21 in) S = 2.62 m (8.58 ft)	885 kph (550 mph) (est)	966 – 1,207 km (600 – 750 mi)	Various: Inertial, GPS, DSMAC	Conventional, various types

USS Halibut (SSGN-587)

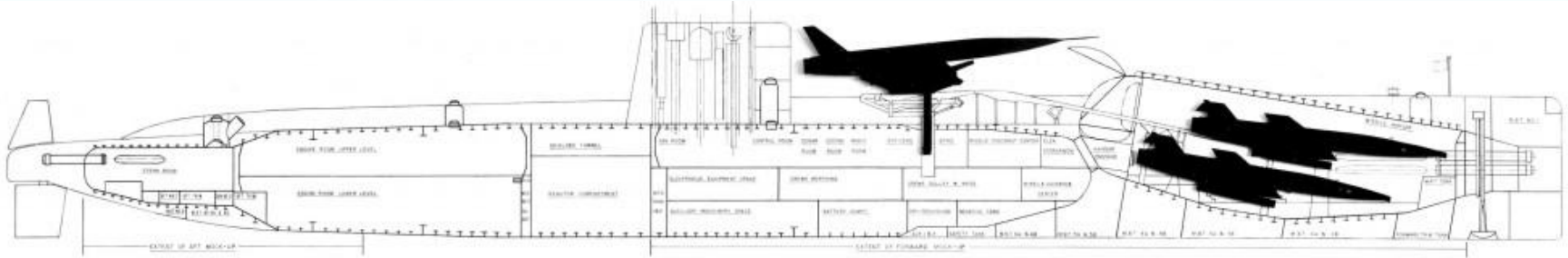

Source: adapted from navsource.org/archives

- *USS Halibut* had the distinction to be the first nuclear submarine in the world designed and built from the keel up to launch guided missiles, and was originally intended to carry five Regulus II missiles in a hangar integral with the hull.
 - Regulus II program was terminated just 17 days prior to *Halibut*'s commissioning in January 1960. *Halibut* departed for her shakedown cruise on 11 March 1960 equipped with Regulus I missiles.
- Propulsion: 1 x S3W Westinghouse PWR rated @ 38 MWt (est); 2 x main steam turbines delivering a total of 7,300 hp (5.4 MW) to 2 x screw
- Armament: 1 x Regulus launcher on deck, forward of the sail; 5 x Regulus I cruise missiles in a watertight hanger; also 6 x 533 mm (21") torpedo tubes; 4 bow tubes, 2 stern tubes
- Operational matters:
 - She is also the first submarine to carry the Sperry Ships Inertial Navigation System (SINS), which was required to align the Regulus II navigation systems (but not required for Regulus I).
 - Enroute to the South Pacific, on 25 March 1960, she became the first nuclear powered submarine to successfully launch a guided missile.
 - First nuclear-powered missile-carrying submarine ever to make extended submerged deterrent patrols. Between February 1961 and July 1964, *USS Halibut* made 7 Regulus missile deterrent patrols.
 - Reclassified as an SSN in April 1965 and later converted for special operations missions.

USS Halibut (SSGN-587)

Halibut made 32 Regulus missile test launches as an SSGN



Source:
navsource.org/archives



Regulus I (SSM-N-8, RGM-6A)

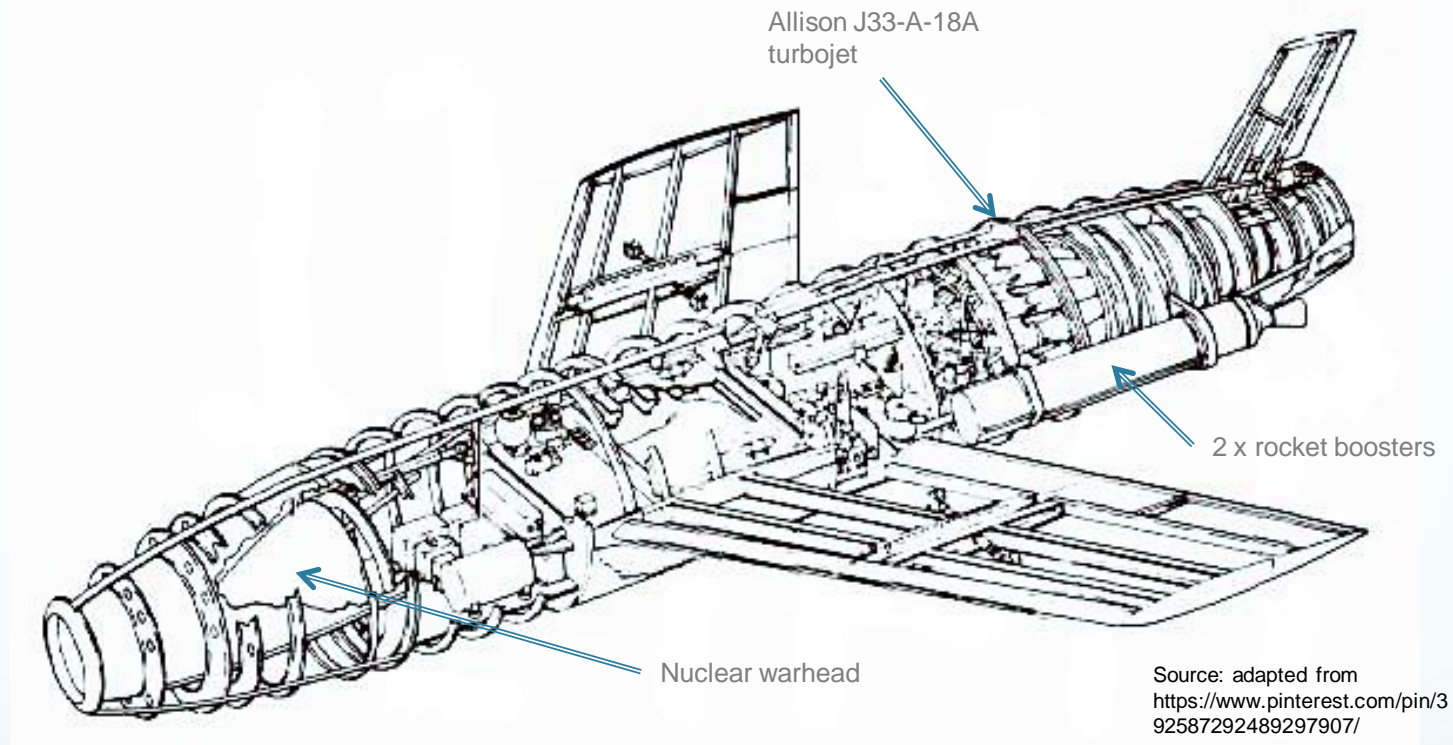

- Regulus I was the first strategic long-range nuclear-armed guided missile deployed by U.S. Navy
 - Designed to carry a 3,990 lb (1,810 kg) warhead 500 nautical miles at high subsonic speed
 - Warhead: initially a 40 kT W5; 2 MT W27 thermonuclear warhead available from 1958
 - Remotely-controlled by aircraft or ships deployed along the flight-path.
- First flight was in March 1951, first shipboard launch from aircraft carrier *USS Princeton* in November 1952, and first submarine launch from *USS Tunny* in July 1953.

Regulus II (SSM-N-9, RGM-15A)

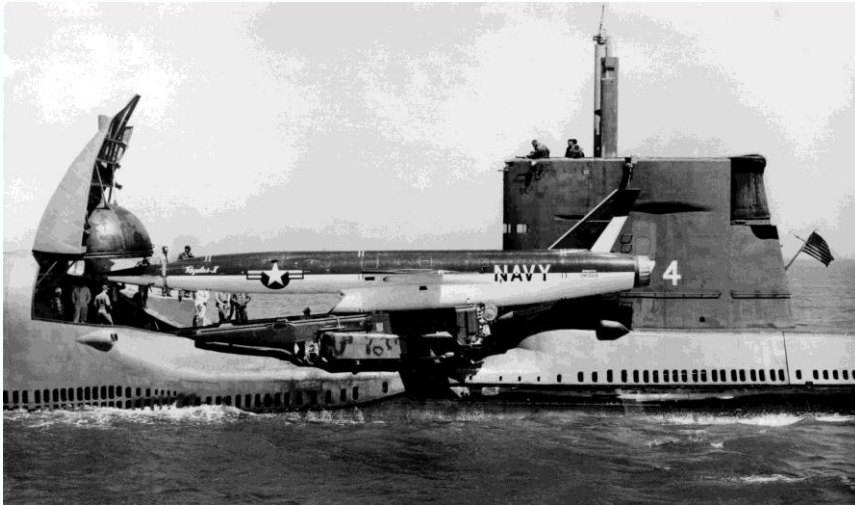

Source: https://en.wikipedia.org/wiki/SSM-N-9_Regulus_II

- Missile had inertial guidance system. Ships equipped with the Regulus II would have been equipped with the Ship Inertial Navigation System (SINS) to align missile's guidance system prior to launch.
- May 1956: first flight of test version XRSSM-N-9
- 48 test flights of Regulus II, but only one submarine launch from *USS Greyback* in Sep 1958
- Regulus II project cancelled 18 Dec 58 in favor of Polaris SLBM.

- Supersonic replacement for Regulus I with greater range, accuracy and an autonomous navigation system.

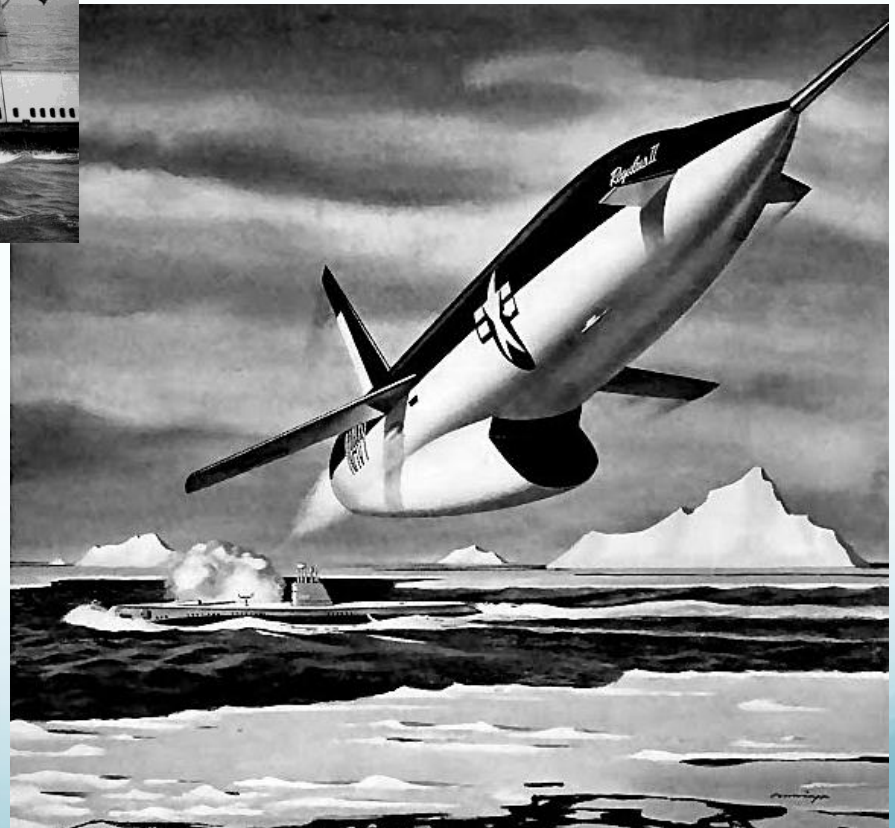

Source: <http://machineagechronicle.com/2011/03/>

Regulus I deterrent patrols

- Deployment on surface ships, 1955 - 1961:
 - First deployed on the heavy cruiser USS Los Angeles (CA-135) in 1955 and later on cruisers *Helena* (CA-75), *Toledo* (CA-133), and *Macon* (CA-132).
 - The first three patrolled in the Pacific, and *Macon* patrolled in the Atlantic.
 - *Macon's* last Regulus patrol was in 1958, *Toledo's* in 1959, *Helena's* in 1960, and *Los Angeles's* in 1961.
 - Ten Essex-class aircraft carriers were equipped to launch Regulus, but few missiles were deployed.
 - *USS Randolph* deployed to the Mediterranean carrying three Regulus missiles.
 - *USS Hancock* deployed once to the Western Pacific with four missiles in 1955.
- Deployment on submarines, September 1959 – July 1964:
 - Five submarines were fitted to launch Regulus missiles: diesel-powered *USS Tunny* (SSG 282), *USS Barbero* (SSG 317), *USS Grayback* (SSG 574) and *USS Growler* (SSG 577), and nuclear-powered *USS Halibut* (SSGN 587). 23 other diesel-powered submarines potentially were available for conversion to SSG role.
 - Sep 1959: *USS Grayback* (SSG-574) started the first Regulus submarine deterrent patrol
 - 41 Regulus submarine deterrent patrols were made
 - July 1964: *USS Halibut* (SSGN-578) completed the last Regulus submarine deterrent patrol

Regulus I deterrent patrols

- In late 1958, with four SSGs and four Regulus cruisers in commission, the Navy moved all of the submarines and three of the cruisers to the Pacific to maintain regular deterrent patrols targeting the Soviet Far East.
 - Sub deployment was scheduled so at least four missiles were on station in the Western Pacific at all times
- Eventually replaced by Polaris SSBN deterrent patrols, which began with the first deployment of the USS George Washington on 15 Nov 1960.

Harpoon (UGM-84A)

anti-ship cruise missile

- Harpoon missiles are carried by submarines, surface ships and aircraft and can land-based (i.e., for coastal defense).
- First deployed in the mid-1970s.
- UGM-84A submarine-launched anti-ship missile is stored and launched in a capsule, from which it is released when the capsule reaches the surface and the booster ignites.
- 488 lb (211.3 kg) penetration / high-explosive blast warhead.
- High-subsonic cruise; 81 mile (130 km) range; inertial guidance at sea-skimming altitude to the target area, then active radar homing to the target.

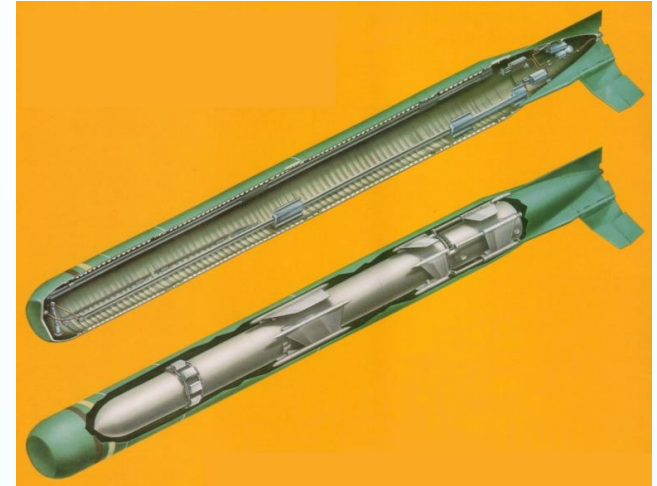

Harpoon capsule

Source: ausairpower.net



Harpoon Missile	
Air Launched	Length - 151.5 In. Weight - 1160 Lb.
Ship Launched	Length - 180.5 In. Weight - 1460 Lb.

Source: ausairpower.net

Tomahawk (UGM-109)

cruise missile

- Launched via torpedo tubes or vertical launcher system tubes.
- UGM-109A, nuclear land-attack version:
 - Launch from surface ships or submarines.
 - W80 thermonuclear warhead
 - 350 built
 - 1986: Initial Operating Capability (IOC)
 - 1992: Retired in accordance with Sep 1991 GHW Bush “Presidential Nuclear Initiatives”
- UGM-109B, anti-ship version:
 - 1990s: Retired in favor of Harpoon anti-ship cruise missile
- UGM-109C, D, E, conventional land-attack version
 - C & E armed with a 1,000 pound-class unitary warhead
 - D armed with a sub-munition dispenser for 166 “bomblets”

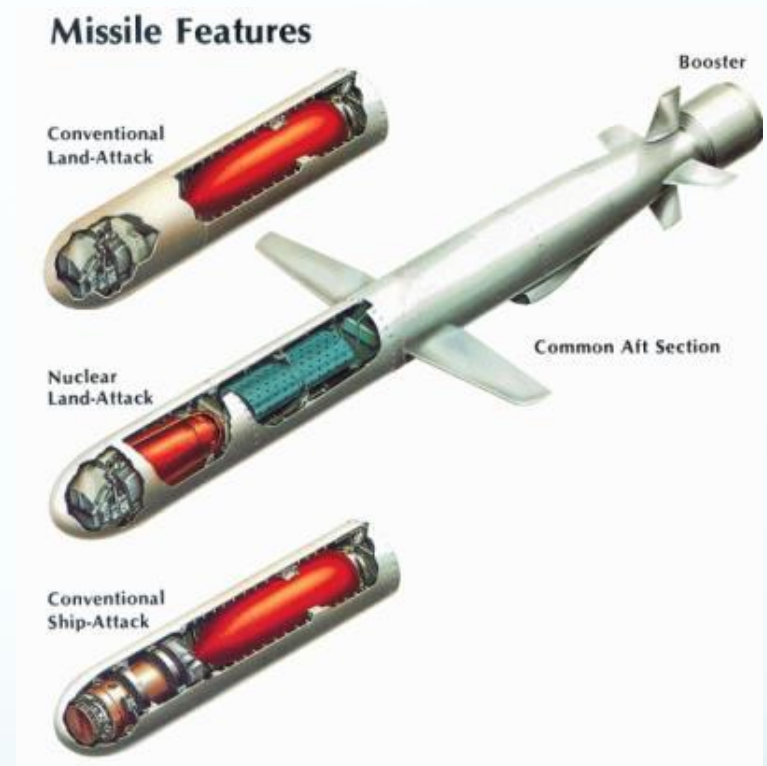

Source: McDonnell Douglas Missile Company

Ohio-class conversion to SSGN

- Under the requirements of the 1992 Strategic Arms Reduction Treaty (START II), the number of U.S. strategic missile submarines was limited to 14 from the year 2002.

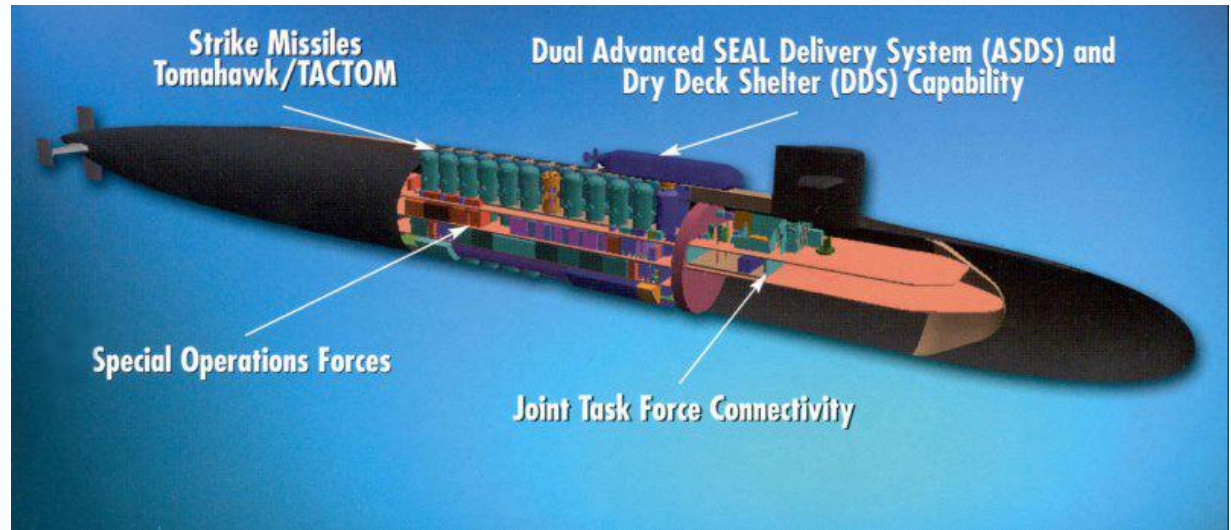

- The first four Ohio-class boats (*Ohio*, *Michigan*, *Florida* & *Georgia*) received an Engineered Refueling Overhaul (ERO) in addition to extensive conversion work to make them capable of conducting conventional land attack and special operations missions:

- 154 Tomahawk cruise missiles in 7 x vertical launcher modules in 22 of 24 missile tubes.
- The remaining two tubes were modified to be lock-in, lock-out chambers for special operations forces
- Up to 66 special operations personnel
- Mission control center

Source: <http://www.public.navy.mil/>



Ohio-class conversion to SSGN

- Operational matters:
 - The Ohio-class SSGNs re-entered service between 2006 - 08. The new S8G reactor cores should have a service life of about 30 years. However, the Ohio-class SSGNs are expected to start retiring in the mid-2020s, with the last boat retiring by about 2029.
 - The significant communications upgrades, including the Common Submarine Radio Room and two high-data-rate antennas, enables each SSGN to serve as a forward-deployed, clandestine Small Combatant Joint Command Center.
 - March 2011: During Operation Odyssey Dawn against the regime of now-deposed Libyan strongman Muammar Gaddafi a total of 283 Tomahawk cruise missiles were launched against Libyan positions by U.S. and UK forces. It was reported that *USS Florida* (SSGN-728) launched about 90 of those missiles.



Ohio with 2 x Dry Deck Shelters for Special Operations Forces (SOF)

Source: <http://defense-update.com>

Ohio SSGN & SOF capabilities to be replaced by Virginia Block V



Block V: VIRGINIA Payload Module (VPM)

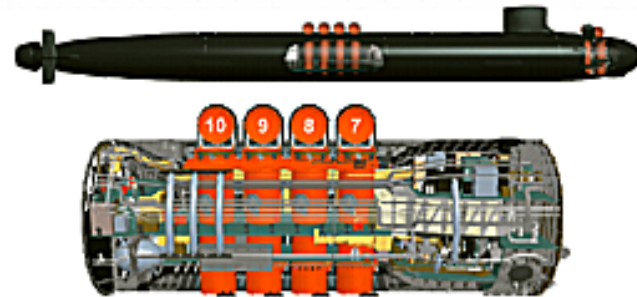
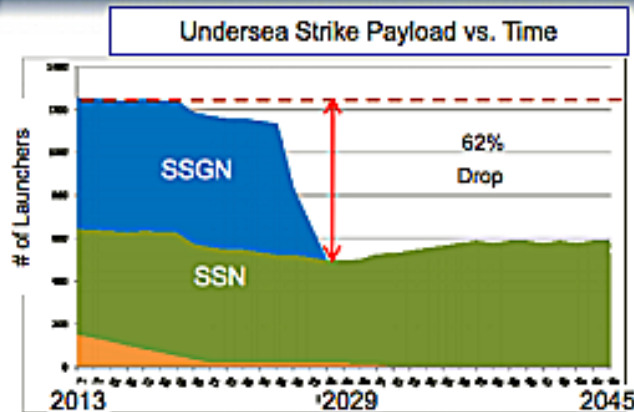

20 VIRGINIAS with VPM close the strike gap

VIRGINIA Payload Module

- Four large tubes in a new hull section
- Uses Multiple All-up Round Canisters (MACs) already employed in SSGN & VIRGINIA Block III Payload Tubes
- Proven VIRGINIA Class construction processes
- Preserves Special Operations Force (SOF) Capacity lost with SSGN retirement

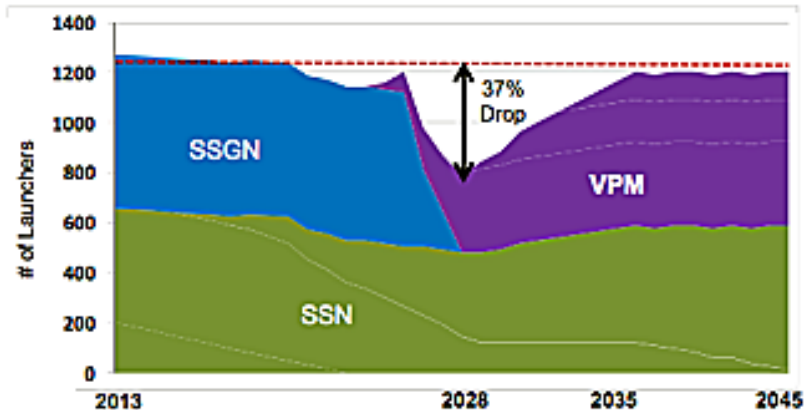

Special operations submarines

Dr. John Piña Craven

- Dr. Craven served in several important positions in the submarine community:
 - At the David Taylor Model Basin he worked on submarine hull designs
 - He was appointed Project Manager for the Polaris SSBN program
 - He served as Chief Scientist at the Navy's Special Projects Office
- In the latter role, his mission was to devise ways of finding items on the deep ocean bed and then finding ways of salvaging some of them.
 - Determining where to look was his special skill. As a mathematician he used Bayesian search theory to produce probability contour maps that helped localize the search zone.
 - 1965: Dr. Craven had the *Halibut* converted into a secret spy ship equipped with a variety of ocean engineering equipment.
 - 1966: Dr. Craven's work was instrumental in the Navy's search for the missing hydrogen bombs that were lost in the Mediterranean off the Spanish coast following a B-52 refueling accident.
 - 1968: Dr. Craven coordinated Halibut's search for Soviet submarine *K-129*, which sank in the Pacific north of Hawaii.
 - 1974: Dr. Craven's involvement in *Project Azorian*, which attempted to recover *K-129*, has not been disclosed.
- Dr. Craven was responsible for the Navy's Deep Submergence Systems Project that included:
 - Sealab and saturation diving technology development
 - Bathyscape *Trieste* development and utilization
- Dr. Craven died on 12 Feb 2015 at the age of 90.
- Suggested reading: *The Silent War: The Cold War Battle Beneath the Sea*, 2001, by Dr. Craven



Source: <http://www.economist.com/news>

U.S. special operations nuclear subs

Class	# in Class	Length	Beam	Displacement (tons)	Reactor	Shaft hp	Max speed (kts)	Year originally delivered	Years in spec op service
Halibut – SSN-575 (former SSGN-575)	1	106.7 m (350 ft)	8.8 m (29 ft)	3,655 (surf), 4,000 (sub)	S3W	7,300	20+	Jan 1960 (as SSGN)	1966 – 76 (Note 1)
Seawolf (SSN-575, after hull extension)	1	122.5 m (402 ft)	8.5 m (28 ft)	>3250 (surf), > 4150 (sub)	S2Wa	13,400	19	Mar 1957 (as SSN)	1973 – 87 (Note 2)
NR-1	1	45 m (147.7 ft)	3.8 m (12.5 ft)	400	1 x PWR	Not known	4.5 (surf) 3.5 (sub)	Oct 1969	1969 – 08
Parche (SSN-683, former Sturgeon-class long-hull)	1	92 m (302 ft)	9.6 m (31.6 ft)	4530 (surf) 5040 (sub)	S5W	15,000	25	Aug 1974 (as SSN)	1978 – 87 (Note 3)
Richard B. Russell (SSN-687, former Sturgeon-class long-hull)	1	92 m (302 ft)	9.6 m (31.6 ft)	4042 (surf), 4339 (sub)	S5W	15,000	25	Aug 1975 (as SSN)	1982 – 94 (Note 4)
Parche (SSN-683, after hull extension)	1	122.5 m (402 ft)	9.6 m (31.6 ft)	7000 (surf) (est), 7800 (sub)	S5W	15,000	< 25	Aug 1974 (as SSN)	1991 – 04 (Note 5)
Jimmy Carter (SSN-23)	1	138 m (453 ft)	12.1 m (40 ft)	7568 (surf) 12,139 (sub)	S6W	52,000	> 25	Feb 2005	2005 – present (Note 6)

1. Converted for special operations Feb 65 – May 66 at Pearl Harbor Naval Shipyard.
2. Converted for special operations Jan 71 – Jun 73 at Mare Island Naval Shipyard; 15.8 m (52 ft) hull extension installed forward of the sail.
3. Originally converted for special operations Oct 76 – Jul 78 at Mare Island Naval Shipyard.
4. Converted for special operations 1982 at Mare Island Naval Shipyard.
5. Additional conversion at Mare Island Naval Shipyard 1987 – 1991; 30 m (100 ft) hull extension installed forward of the sail.
6. Originally commissioned in special operations form, with a 30 m (100 ft) hull extension installed aft of the sail

USS Halibut (SSN-587)

Special operations submarine

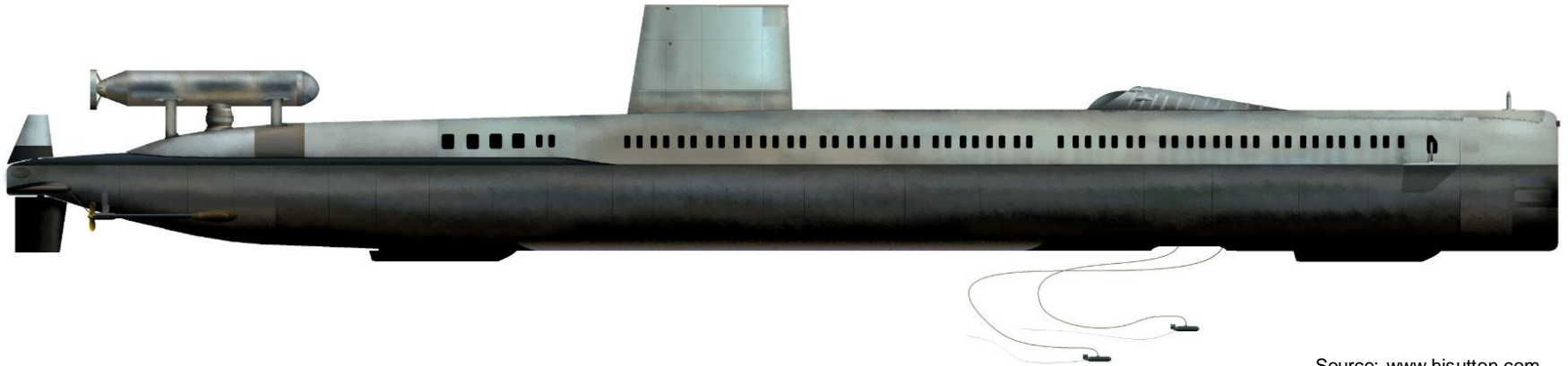

Source: www.hisutton.com

- February 1965: After serving as an SSGN since 1960, *Halibut* entered Pearl Harbor Naval Shipyard for a major overhaul, and in May 1966 resumed service as an SSN with the Deep Submergence Group, which was involved in deep sea search & recovery.
 - *Halibut* gained the capability to operate a towed underwater search vehicle ("fish") for deep under-sea surveys
 - With bow and stern thrusters, *Halibut* could hover for hours over objects on the sea bed.
- Operation Sand Dollar:
 - July 1968: *Halibut* was given the mission of locating Soviet submarine K-129, a diesel-powered Golf II strategic missile submarine (SSB) that sank in February 1967 in water three miles deep in the northern Pacific.
 - *Halibut* lowered a remotely-controlled vehicle three miles to the ocean floor, took 22,000 photos, and located the Russian submarine.
 - Under the later Project Azorian, an attempt was made to recover K-129 using the Glomar Explorer

USS Halibut (SSN-587)

Special operations submarine

- August 1968: *Halibut* was transferred to Mare Island Naval Shipyard for overhaul and installation of additional special operations equipment, including:
 - long- and short-range side-looking sonar
 - side thrusters
 - port and starboard, fore and aft seabed skids ("sneakers")
 - anchoring winches with fore and aft mushroom anchors
 - hangar section sea lock
 - saturation diving (mixed-gas) habitat
- In late 1970, after modifications were complete, *Halibut* was assigned to Submarine Development Group One, San Diego.
- 1971 – 1976: *Halibut* was engaged in Operation Ivy Bells
- *Halibut* was decommissioned on 30 June 1976. It's special operations role was taken over by *Seawolf* and later by *Parche*.

Operation Ivy Bells

- October 1971: *USS Halibut* embarked to locate and tap an underwater communications cable that ran from the Soviet missile submarine base at Petropavlovsk, on the Kamchatka peninsula, under the Sea of Okhotsk, to Fleet headquarters near Vladivostok.
 - The cable was found at a depth of about 400 ft., tapping coils were wrapped around the cable, and the ability to record messages was demonstrated.

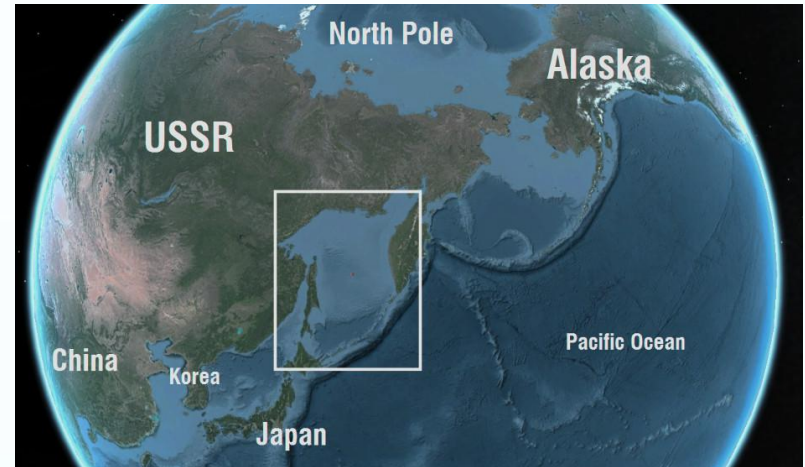

Source: www.hisutton.com

- 1972: *Halibut* returned and placed a high capacity induction recording pod next to the cable.
 - Recording pod was 20 feet and weighed about 6 tons, and was designed to detach if the cable was raised for repair.
 - The recording technique involved no physical damage to the cable and was unlikely to have been readily detectable.
 - The pods were designed by AT&T.
 - Some or all of the pods were powered by a radioisotope thermoelectric generator (RTG).
- *Halibut* and other special operations subs (*Seawolf* & *Parche*) visited the tap location regularly to exchange recording tapes and/or install an improved pod.

Operation Ivy Bells

- In the summer of 1979, *USS Parche* travelled from San Francisco under the Arctic ice to the Barents Sea, and laid a new cable tap near Murmansk.
- The U.S. continued this operation undetected until 1981, when one day, surveillance satellites showed a number of Soviet warships, including a salvage ship, anchored over the undersea cable.
- Special operations submarine *USS Parche* (SSN-683) was sent to the site to retrieve the pod. *Parche's* divers were unable to find the pod, which had been recovered by the Soviets.

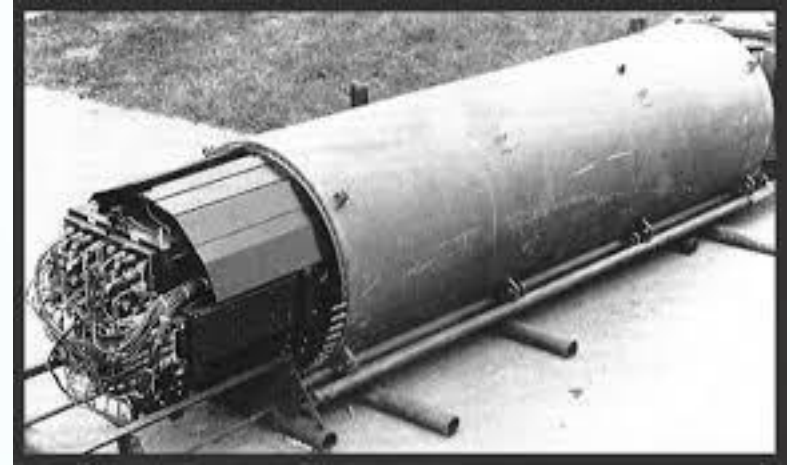

Source: www.usmilitaryforum.com

- After a long investigation, it was determined that Operation Ivy Bells was revealed to the Soviets in classified information given to them by NSA employee Robert Pelton for payments totaling \$35,000.
- One of the IVY BELLS pods is now on display in the Moscow museum of the former KGB.
- During 1985, cable-tapping operations were extended into the Mediterranean, to intercept cables linking Europe to West Africa
- The cable tap in the Barents Sea continued in operation, undetected, until tapping stopped in 1992
- After the cold war ended, the *USS Parche* was refitted with an extended section to accommodate larger cable tapping equipment and pods. Cable taps could be laid by remote control, using drones

Legacy of Ivy Bells

- According to a 2013 article in the *Washington Post*, the U.S.'s National Security Agency (NSA) has a modern-day cable-tapping program, known by the names OAKSTAR, STORMBREW, BLARNEY and FAIRVIEW that accesses "communications on fiber cables and infrastructure as data flows past." Apparently the UK and other nations have similar programs.
- TeleGeography, a global research firm, claims that undersea cables carry 99% of all intercontinental data, a category that includes most international phone calls.

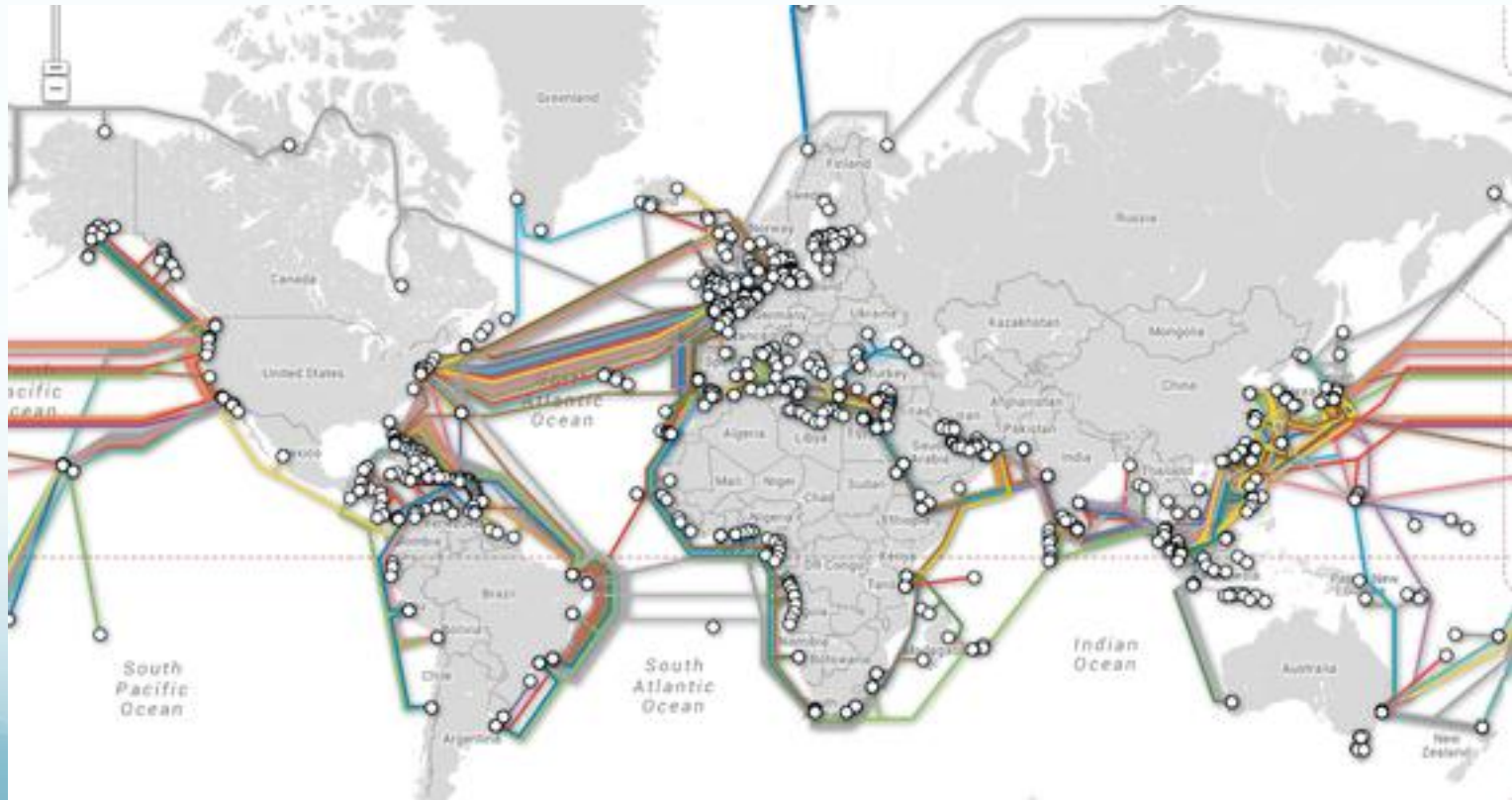

550,000 miles of undersea cables connect the world

Source: <https://www.telegeography.com>

USS Seawolf (SSN-575)

Special operations submarine

- After serving as an SSN since 1957, *Seawolf* was in Mare Island Naval Shipyard from early 1971 to mid-1973 for modifications for special operations missions, including installation of:
 - A new 15.8 m (52 ft) “special projects” hull section forward of the sail,
 - Bow and stern thrusters, and
 - Other systems similar to those installed on *Halibut* to support saturation divers and operation of remote underwater vehicles.

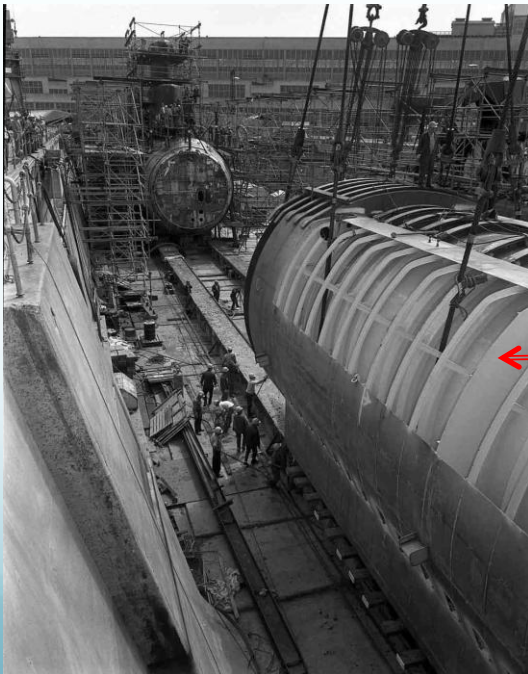

Hull insert
being
installed
in drydock

Bow
thrusters



USS Seawolf (SSN-575)

Special operations submarine

USS Seawolf (SSN-575)
Special Projects boat

COVERT SHORES
www.hisutton.com

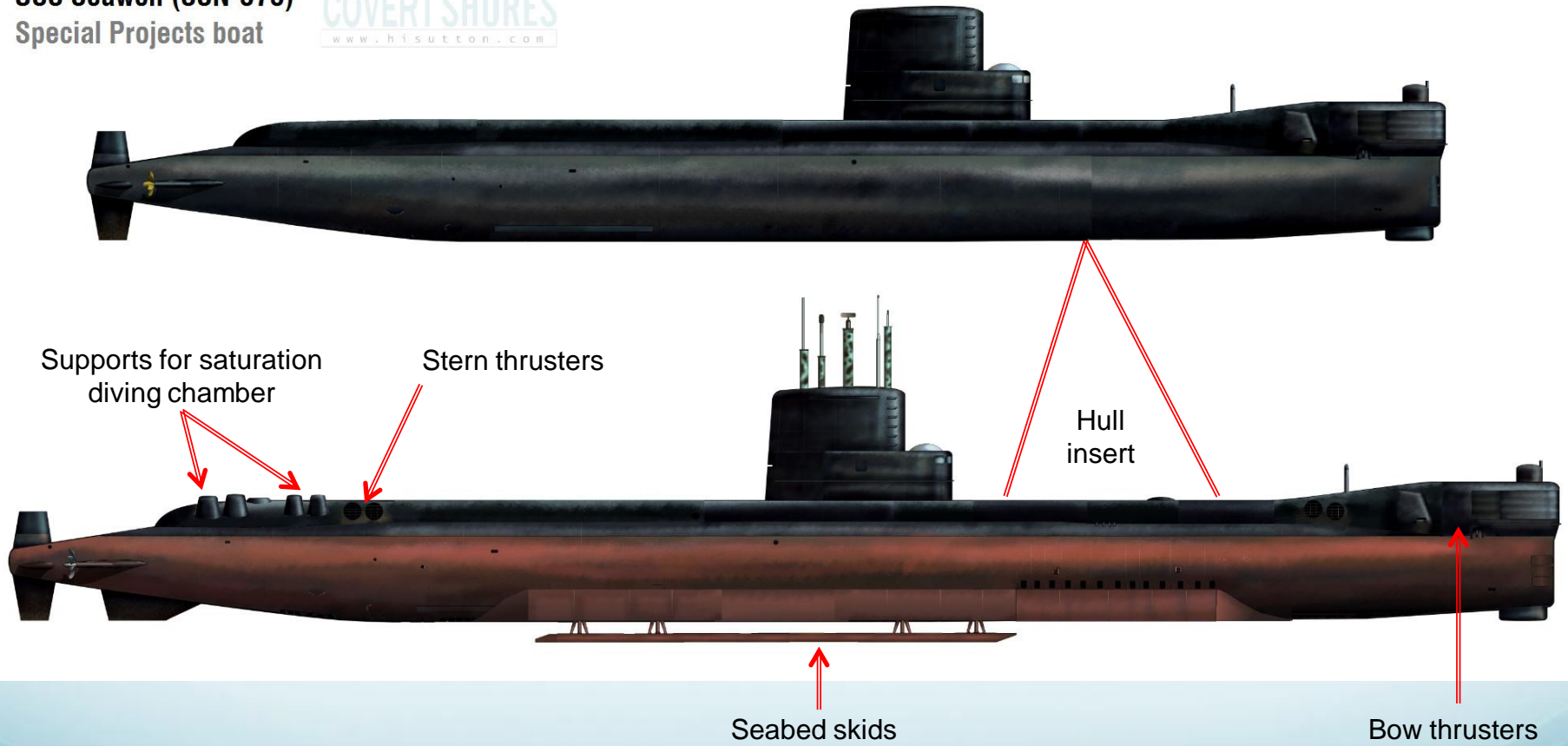

Source: adapted from www.hisutton.com

USS Seawolf (SSN-575)

Special operations submarine

- 1974: *Seawolf* became fully operational and conducted her first Pacific Fleet deployment, which included operating independently for a period of three months.
- Late 1974: *Seawolf*, equipped with special cameras that were lowered to the seabed, examined the site of the failed attempt to raise Soviet submarine K-129.
 - The survey found wreckage scattered over a wide area
 - A second recovery attempt by *Glomar Explorer* was not made
- 1975: *Seawolf* came under the exclusive direction of Submarine Development Group One
- 1975 – 78: *Seawolf* conducted *Operation Ivy Bells* and repeatedly visited the listening devices originally placed in 1972 by *Halibut* on submarine communications cables in the Okhotsk Sea.
 - The *Seawolf* exchanged tapes and brought the them back for evaluation.

USS Seawolf (SSN-575)

Special operations submarine

- 1978: *Seawolf* was refueled
- 1979 – 1982: *Seawolf* continued conducting Operation Ivy Bells
 - On one mission, the boat returned to the Sea of Okhotsk, installed new recording devices and removed the old units. The boat was damaged during this operation, but returned to port and was brought into dry dock for repairs.
 - In 1982, *Operation Ivy Bells* ended.
- Thereafter, *Seawolf* continued to be used to locate and recover items in the open sea.
 - In 1984, *Seawolf* conducted a 93-day deployment to the western Pacific, then the longest submerged deployment of any submarine.
- June 1986: *Seawolf* returned to Mare Island to prepare for decommissioning
- March 30, 1987: *Seawolf* was decommissioned

Naval Reactors 1 (NR-1)

Special operations submarine



Source: <http://navsource.org/archives/>



Source: <http://www.navy.mil/navydata>

- NR-1 entered service on Oct 1969 as a one-of-a-kind small nuclear submarine capable of operating at great depth and with long endurance (16 – 25 days), even in heavy weather.
 - It conducted military and civilian missions
- NR-1 is equipped to search for and recover items from the sea floor and to map the sea floor
 - Searches and mapping are facilitated by a sub-bottom profiler and a side-scan sonar system that can produce images of the search area
 - A set of deployable wheels allows NR-1 to ride along the contours of the sea bottom
- NR-1 generally was towed to and from remote mission locations by an accompanying surface tender, which was also capable of conducting research in conjunction with the submarine.
- NR-1 was deactivated in Nov 2008, de-fuelled at Portsmouth Naval Shipyard, and sent to Puget Sound Naval Shipyard (PSNS) to be scrapped.
- Suggested reading: *Dark Waters: An Insider's Account of the NR-1 The Cold War's Undercover Nuclear Sub*, 2003, Lee Vyborny

Naval Reactors 1 (NR-1)

Special operations submarine

RANDMR1395-2.1

Search capabilities

- Side-looking sonar
 - 600 ft (180 m) search width 1 ft (30 cm) resolution or
 - 2,400 ft (730 m) search width with 4 ft (1.2 m) resolution
- Deep Submergence/Obstacle Avoidance Sonar (DS/OAS)
 - Compatible with Deep Ocean Transponder (DOT) for both bottom survey and local navigation
- Sub-bottom profiler
 - Variable power
 - Selectable frequency

Principal characteristics

Length overall	145 ft 9- ⁷ / ₁₆ in. (44.4 m)
Pressure hull length	96 ft 1 in. (29.3 m)
Diameter	12 ft 6 in. (3.8 m)
Maximum beam (at stern stabilizers)	15 ft 10 in. (4.8 m)
Maximum navigational draft	15 ft 1 in. (4.6 m)
Box keel depth (below baseline)	4 ft 0 in. (1.2 m)
Design operating depth	2,375 ft (724 m)
Displacement submerged	366 long tons, 409.92 short tons
Speed, surface/submerged	4.5/3.5 knots
Mean draft	15 ft ³ / ₄ in. (4.6 m)
Endurance	210 man-days (nominal) 330 man-days (maximum)

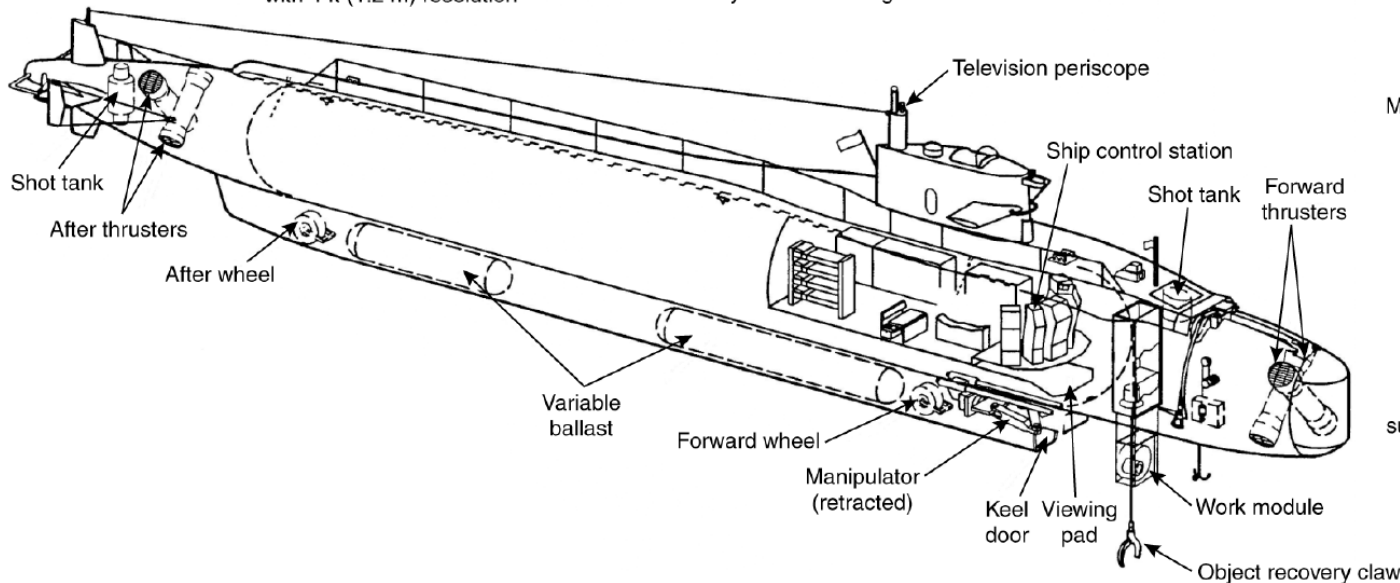

Source: RAND document MR1395-2.1

Naval Reactors 1 (NR-1)

Special operations submarine



- *NR-1* carried a crew 11, all of whom are nuclear-propulsion certified.
- Details on the small PWR powerplant have not been released.

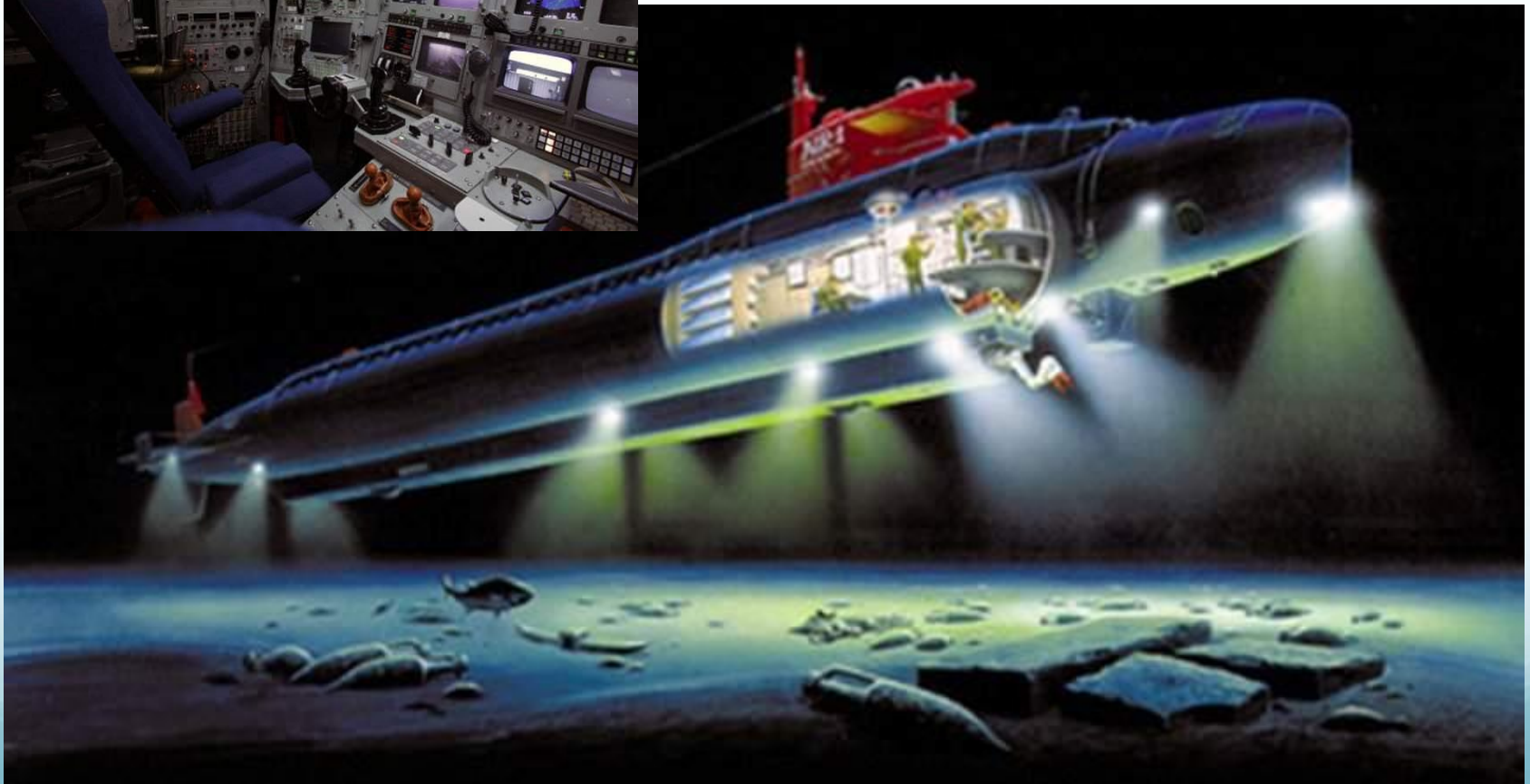

NR-1 survey of the *USS Monitor*

- *USS Monitor*, launched on 30 January 1862, served during the Civil War as the Navy's first ironclad warship.
- The Navy has an on-going *Monitor Project* to research and, perhaps ultimately, to recover the vessel.
- Because of strong currents along the bottom, initial efforts to obtain detailed site data had failed. *NR-1's* exceptional stability and power made it possible for the sub to scan the entire hull with side-looking sonar and help determine the ship's structural integrity with relative ease.
- These images provide an example of the *NR-1's* unique undersea search and mapping capabilities.

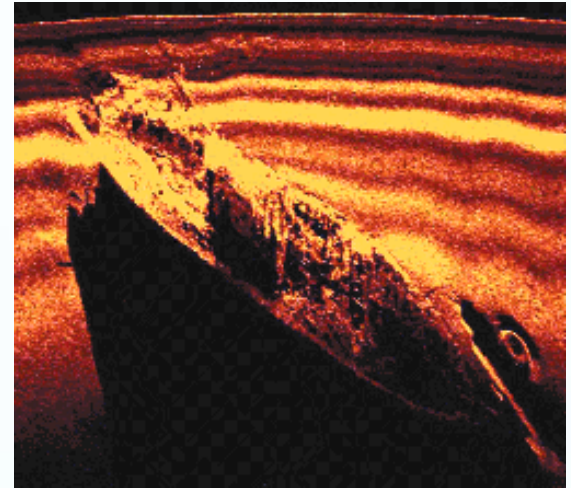

NR-1 sonar images of USS Monitor

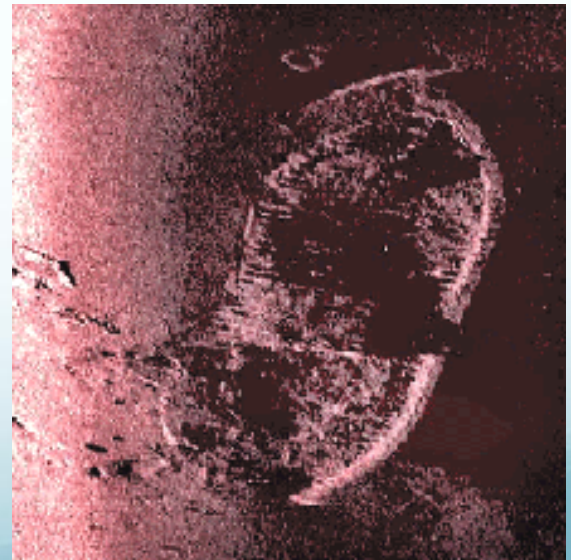

NR-1 replacement studies

- *NR-1* was deactivated in 2008, but there are no active plans for building a replacement.
- Results of prior replacement studies in 1990 and 1999 are shown in the accompanying diagram.
- A 2002 Rand study examined the capabilities that an *NR-2* platform might incorporate and the associated mission profiles that could use these capabilities (see Rand report MR1359).
- The Russians are building advanced, nuclear-powered special operations / deep-ocean exploration subs that are much more capable than *NR-1*.
 - The latest is *Losharik*, which became operational in 2003.

RANDMR1395-B.1

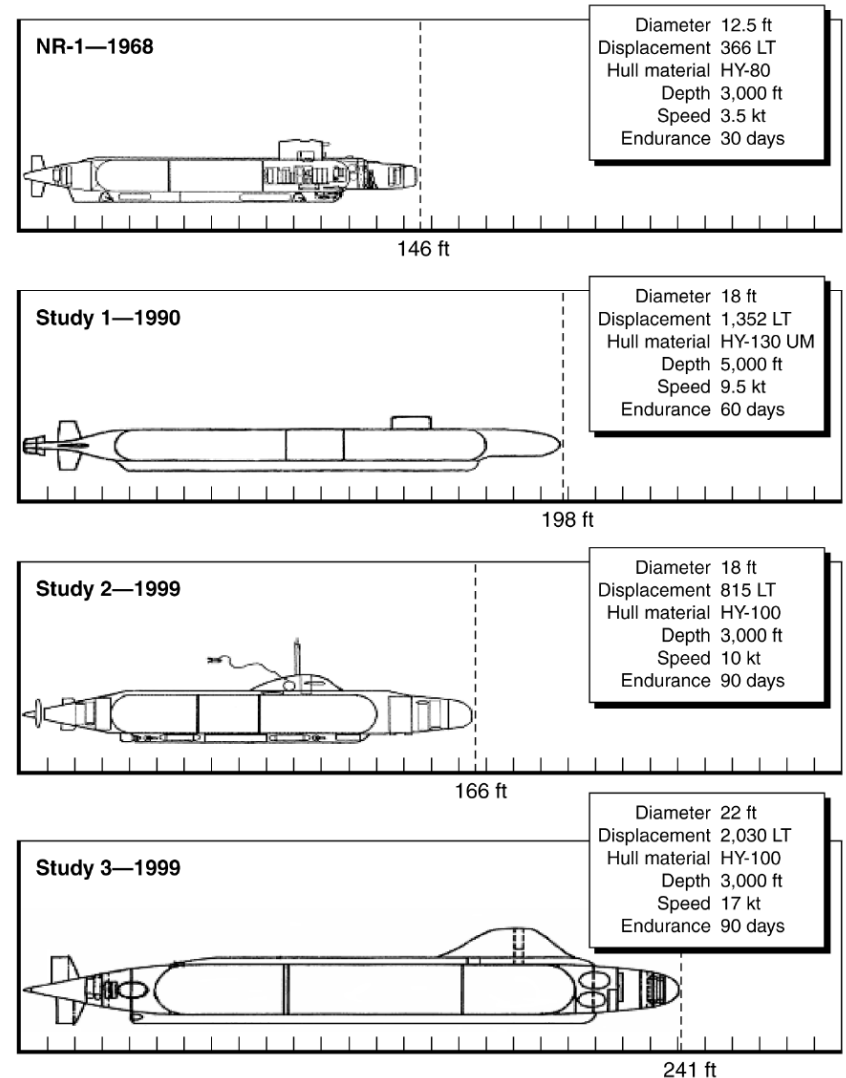

Source: RAND document MR1395-2.1

USS Parche (SSN-683)

Sturgeon-class special operations sub

- Originally a long-hull Sturgeon (637)-class sub, commissioned Aug 1974.
- Oct 1976: *Parche* entered Mare Island Naval Shipyard for various ocean engineering modifications needed for special operations missions.
- In the 1970s, *Parche* conducted *Ivy Bells* missions to place wiretaps on Russian underwater communications cables and to periodically retrieve recordings.
- In 1980, a former NSA employee named Ronald Pelton provided classified information that revealed *Ivy Bells* missions to the Soviets in exchange for about \$35,000. Pelton was arrested in 1986, tried and convicted. He remains in federal prison.



Parche circa 1983. The “DSRV-look-alike” structure on the boat’s aft section was a lock in-lockout chamber for saturation divers
Source: www.navsourc.org

USS Parche (SSN-683)

Sturgeon-class special operations sub

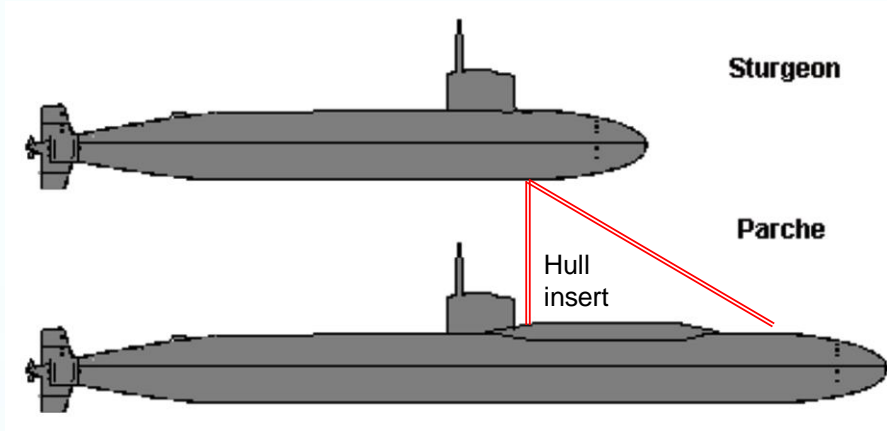

- 1987 to 1991: *Parche* underwent an extended refueling overhaul at Mare Island Naval Shipyard during which a 30 m (100 ft) hull extension for “research and development” was added just forward of the sail to provide space for additional crew and special mission equipment:
 - Intelligence gathering
 - Underwater salvage
- Reportedly, *Parche's* “ocean engineering” equipment includes remotely-operated underwater vehicles and a remote grapple extended through a hatch in the submarine's keel to locate and salvage relatively small items on the ocean floor (i.e., missile parts, reentry vehicles).
- *Parche* resumed Pacific Fleet operations in 1992.
- Decommissioned in 2004

USS Richard B. Russell (SSN-687)

Sturgeon-class special operations sub

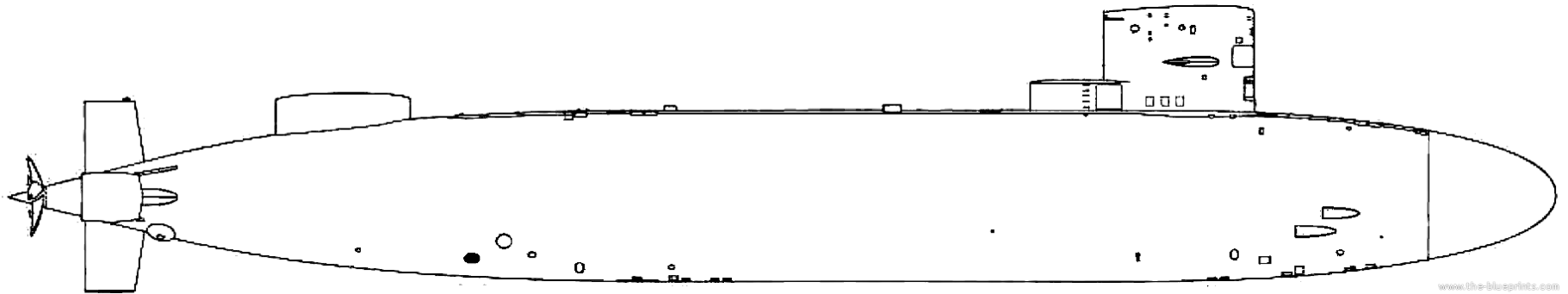

www.the-blueprints.com

Source: the-blueprints.com



Source: www.navsource.org

- Originally a long-hull Sturgeon (637)-class sub commissioned in Aug 1975. The “bustle” aft of the sail housed a tethered antenna buoy.
- 1982 *Russell* entered Mare Island Naval Shipyard for various ocean engineering modifications needed for special operations missions with Submarine Development Group 1.
- *Russell* was involved in a testing program for submarine rescue technology.
- Decommissioned in 24 June 1994

USS Jimmy Carter (SSN-23)

Seawolf-class special operations sub

Multi-Mission Platform

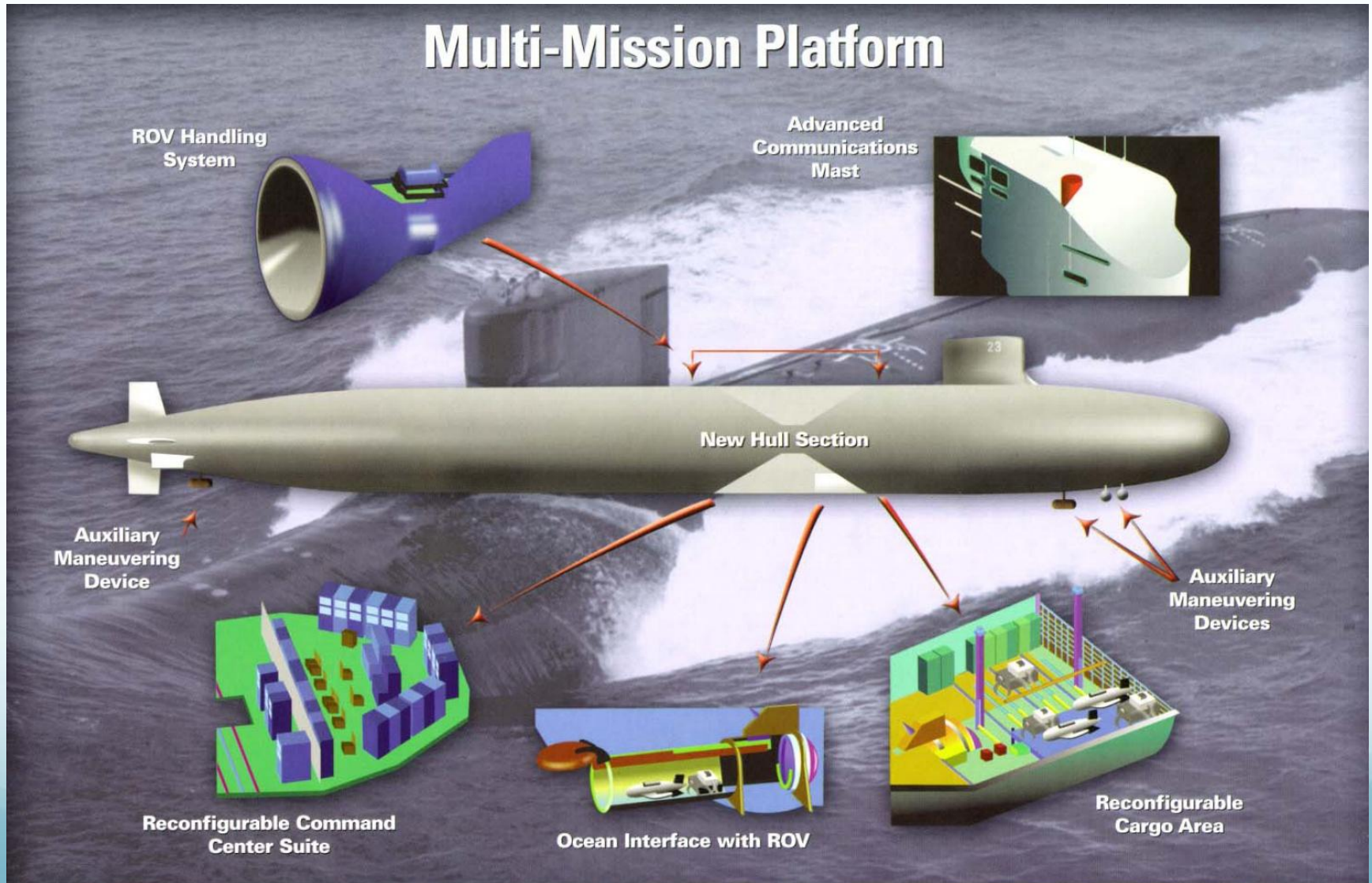

USS Jimmy Carter (SSN-23)

Seawolf-class special operations sub



Source: reuters.com

- Electric Boat inserted a 100 ft, 2,500 ton, Multi-Mission Platform (MMP) extension in the middle of *Jimmy Carter's* hull, adding nearly \$1 billion to the baseline \$2 billion price of a Seawolf-class sub
- The MMP includes an ocean interface to allow divers, remotely-operated vehicles, and other machinery to move between the sub's interior and the ocean. Such capabilities can be used for retrieving objects off the seafloor or deploying monitoring devices and other surveillance equipment.

- Length: 453 ' (138.1 m)
- Displacement:
 - 10,069 t surfaced (est)
 - 12,157 t submerged
- Can accommodate a Dry Deck Shelter or an Advanced SEAL Delivery System for Special Operations Forces (SOF) on the top deck, behind the sail.
- Retains all the warfighting capabilities of other Seawolf-class SSNs.



Source: www.bluebird-electric.net

Comparison of SSN-21 & -23

SSN-21, *USS Seawolf*



107.6 m (353 ft)

138.1 m (453 ft)

SSN-23, *USS Jimmy Carter*



U.S SEAL delivery subs

- Ethan Allen-class FBM subs *Sam Houston* (SSBN-609) & *John Marshall* (SSBN-611):
 - 1981: In compliance with SALT I treaty, the Polaris missile sections on these subs were deactivated (concrete in missile tubes, fire control system & one SINS removed), and these former SSBNs were reclassified as SSNs.
 - 1982 – 1983: Both were modified to carry 2 x Dry Deck Shelters (DDS) on the top deck, behind the sail when deployed to conduct special warfare operations.
 - *Sam Houston* was deactivated March 1991; *John Marshall* was deactivated early 1992.
- Ben Franklin-class FBM subs *Kamehameha* (SSBN-642) and *James K Polk* (SSBN-645):
 - 1992 - 1994: The Polaris missile sections on both boats were deactivated and modified to carry 2 x DDS
 - 1994: Both boats were reclassified as SSNs and deployed to conduct special warfare operations.
 - *Polk* was deactivated in 1999; *Kamehameha* was deactivated in 2002. At that time *Kamehameha* was the last original FBM submarine and the oldest sub in the fleet, with 37 years of service.
- SEAL delivery missions continue with Ohio-class SSGN-conversions, which can carry 2 x DDS, and SSNs, which can carry 1 x DDS.

USS Kamehameha (SSN-642)

after 1992 conversion to SSN with two Dry Deck Shelters



SSN with Dry Deck Shelter (DDS)

- A DDS provides specially configured nuclear powered submarines with a greater capability of deploying Special Operations Forces (SOF).
- DDSs can transport, deploy, and recover SOF teams from Combat Rubber Raiding Crafts (CRRCs) or SEAL Delivery Vehicles (SDVs), all while remaining submerged.
- Six Sturgeon-class SSNs were the first SSNs to be configured to carry a DDS: SSN-678, -679, -680, -682, -684, & -686.
- *USS Dallas* (SSN-700) was the first Los Angeles-class submarine to have a DDS, shown mounted on the deck aft of the sail.
- Other Los Angeles-class, Seawolf-class & Virginia-class SSNs are equipped to carry a DDS.
- In an era of littoral warfare, this capability substantially enhances the combat flexibility of both the submarine and SOF personnel.



Source: www.navy.mil

SEAL Delivery Vehicle (SDV)

Carried by SSNs & Ohio SSGNs

- Mk 8 Mod 1 SDV is a manned, flooded, battery-powered submersible that can deliver several fully equipped SEALs to a mission area, be "parked" or loiter in the area, retrieve the SEALs, and return to a designated point.
- The SDV pilot and co-pilot may be part of the fighting team.
- The SDV typically is stored in a Dry Deck Shelter on a submarine, but also can be deployed from amphibious surface ships, large helicopters, or air-dropped from a C-130 transport.



Source: www.sinodefenceforum.com, Jeff Head Oct 13, 2014



Source: www.news.navy.mil



Source: <https://en.wikipedia.org>

Advanced SEAL Delivery System (ASDS) mini-sub

- ASDS-1 was designed to carry 16 SEALs + 2 pilots in 3 compartments: operations, diver lock-out & troop transport.
- Length: 65'; beam: 6.75'; Displacement: 60 tons
- Propulsion: 67 hp (50 kW) electric motor; max speed 8+ kts; Range: 125+ miles

688-class submarine *USS Greenville* (SSN-772) with ASDS-1 in 2003



ASDS-1 minisub in 2004



- Original silver-zinc batteries provided insufficient power for the craft's missions, and more powerful lithium-ion batteries were substituted.
- Nov 2008: battery fire during recharging caused significant damage to ASDS-1.
- The mini-sub was not repaired and the program was cancelled.

U.S. Navy nuclear-powered surface ships

Cruisers and Aircraft Carriers

Evolution of the U.S. nuclear-powered surface fleet

- Dec 1957: Keel laid for 1st nuclear powered cruiser (CGN) *USS Long Beach*
- Feb 1958: Keel laid for 1st nuclear powered aircraft carrier (CVN) *USS Enterprise*
- 1961: The 1st U.S. nuclear-powered surface vessel, *USS Long Beach* (CGN-9), was commissioned 9 Sep 1961, just 2-1/2 months before the *USS Enterprise* (CVN-65) was commissioned on 25 Nov 1961.
- 1962: *USS Bainbridge*, originally classified as a “Destroyer leader” (sized between a destroyer and a cruiser), was commissioned on 6 Oct 1962 as DLGN-25.
- 1964: The benefits of an all-nuclear-powered strike force was demonstrated in 1964 with Operation Sea Orbit, in which the all-nuclear Task Force One, comprised of *USS Enterprise* (CVN-65), *USS Long Beach* (CGN-9), and *USS Bainbridge* (DLGN-25, later CGN-25), circumnavigated the globe in 65 days without refueling or replenishment.

Evolution of the U.S. nuclear-powered surface fleet

- 1964: Keel laid for aircraft carrier *John F. Kennedy*, which originally was planned to be a nuclear-powered carrier, but revised after construction started to be the last conventionally-powered carrier, CV-67.
- 1975: 1st Nimitz-class aircraft carrier commissioned, CVN-68, *USS Nimitz*.
- 1974: The DoD Authorization Act for FY1975 made it a matter of U.S. policy that all future large combatants intended to serve with strike forces should be nuclear powered, unless the President specifically waived that condition.
- mid-1970s: The Navy designed a modified Virginia-class CGN with the new Aegis combat system, to be known as CGN-42, and a larger nuclear-powered “strike cruiser” (CSGN).

Evolution of the U.S. nuclear-powered surface fleet

- As reported by Congressional Research Service, “procurement of nuclear-powered cruisers was halted after FY1975 largely due to a desire to constrain the procurement costs of future cruisers.”
 - The Secretary of Defense had made the assessment that, “the military value of an all-nuclear-powered Aegis ship program does not warrant the increased costs or, alternatively, the reduced force levels.” CGN-42 and CSGN were not procured.
 - The first conventionally-powered Ticonderoga-class Aegis cruisers were procured in FY1978, with a total of 27 joining the fleet through 1994.
- 1980: The last of nine nuclear-powered cruisers was commissioned.
- Early 1990s: Due to budget cutbacks and obsolescence (relative to Aegis cruisers) of the combat systems on the nuclear-powered cruisers, the Navy decided to cancel mid-life CGN refueling and decommission all CGNs at the end of their current reactor operating cycles.
- 1999: The last CGN was decommissioned. The U.S. nuclear-powered surface fleet was comprised only of aircraft carriers.

Evolution of the U.S. nuclear-powered surface fleet

- 2005 Naval Reactors Quick Look Analysis
 - This analysis developed preliminary life-cycle cost estimates (procurement cost + life-cycle operating and support cost + post-retirement disposal cost) for two classes of ships:
 - A surface combatant similar to past CGNs
 - A large-deck (LHA-type) amphibious assault ship
 - The analysis then determined the break-even fossil fuel price needed to equalize the life-cycle cost of a nuclear-powered vessel and its conventionally-powered counterpart. The break-even crude oil prices were:
 - \$178 per barrel for a surface combatant
 - \$70 per barrel for a large-deck (LHA-type) amphibious assault ship
 - The analysis did not quantify the mobility-related operational advantages of nuclear propulsion for a surface ship.
 - The analysis was based on a 40-year ship life, which is roughly consistent with the expected service life of an amphibious assault ship, but five years longer than the 35-year life the Navy now plans for its cruisers and destroyers.

Evolution of the U.S. nuclear-powered surface fleet

- 2006 Navy Alternative Propulsion Study
 - More detailed study; superseded the 2005 NR Quick Look Analysis
 - The procurement costs of nuclear vessels are significantly higher than for their conventionally-powered counterparts
 - For a small surface combatant, the procurement-cost increase was about \$600 million.
 - For a medium-size combatant (defined as a 21,000 - 26,000 metric ton vessel with a 30 - 31 MWe combat system), the increase was in the \$600 - \$700 million range
 - For a large-deck amphibious ship, the increase was about \$800 million
 - Although nuclear-powered ships have higher procurement costs than conventionally powered ships, they have lower operating and support costs when fuel costs are taken into account.
 - At a crude oil cost of \$74.15 per barrel (which was a representative 2006 market price), the life-cycle cost premium of nuclear power is:
 - 17% to 37% for a small surface combatant
 - 0% to 10% for a medium sized surface combatant
 - 7% to 8% for an amphibious ship
 - A nuclear-powered medium-size surface combatant is the most likely of the three ship types studied to prove economical, depending on the operating tempo that the ship actually experiences over its lifetime.

Evolution of the U.S. nuclear-powered surface fleet

- 2008: Section 1012 of the FY2008 Defense Authorization Act (again) makes it U.S. policy to construct major combatant ships of the Navy with integrated nuclear power systems, unless the Secretary of Defense submits a notification to Congress that the inclusion of an integrated nuclear power system in a given class of ship is not in the national interest.
- 2009: The last of 10 Nimitz-class CVNs was commissioned. The keel was laid for the first Ford-class CVN.
- 2010: The Congressional Research Service published, *“Navy Nuclear-Powered Surface Ships: Background, Issues, and Options for Congress,”* reported:
 - The procurement cost of the initial nuclear fuel core is included in the total procurement cost of the ship, which is funded in the Navy’s shipbuilding budget:
 - In constant FY2007 dollars, the initial fuel core for a Virginia (SSN-774)-class submarine cost about \$170 million
 - The initial fuel cores for a Nimitz-class aircraft carrier, which uses two reactors, have a combined cost of about \$660 million.

Evolution of the U.S. nuclear-powered surface fleet

- 2010: The Navy studied nuclear power as a design option for a new cruiser design, CG(X), but cancelled CG(X) in favor of procuring smaller, conventionally-powered surface combatants: Arleigh Burke (DDG-51) Flight III-class Aegis destroyers.
- 2012: *USS Enterprise* (CVN-65) retired, reducing the U.S. carrier force to 10, which is below the Congressionally-mandated fleet of 11 CVNs.
- 2016: The U.S. carrier force will be restored to 11 CVNs when the *Gerald R. Ford* (CVN-78) is commissioned in 2016.
- Following years:
 - Nimitz-class carriers will be retired on a one-for-one basis as the new Ford-class carriers are commissioned.
 - No other new nuclear-powered naval surface vessels are expected to be built in the near future.

Nuclear-powered cruisers

- Modern cruisers are large multi-purpose ships providing anti-aircraft / missile defense and anti-submarine defense for carrier task forces.
- For this class of ship, the primary benefit of nuclear power is independence from the need to refuel, enabling high-speed deployment over long distances, ability to commence combat operations immediately upon arrival in the theater of operations, and long on-station time.
- In contrast to an aircraft carrier, the nuclear power plant of a cruiser was a greater fraction of the total building and operating costs.

Class	# in Class	Length	Beam	Displacement (tons)	Reactor	Shaft hp	Max speed (kts)	Years delivered	Years in service
Long Beach (CGN-9)	1	219.7 m (721 ft)	22.3 m (73 ft)	17,100	2 x C1W	80,000	30+	1961	1961 - 95
Bainbridge (CGN-25)	1	172.2 m (565 ft)	17.6 m (57.7 ft)	8,580	2 x D2G	60,000	34	1962	1962 - 96
Truxtun (CGN-35)	1	171.9 m (564 ft)	17.7 m (58 ft)	8,800	2 x D2G	60,000	31	1967	1967 - 95
California (CGN-36)	2	181.8 m (596 ft)	18.6 m (61 ft)	10,530	2 x D2G	60,000	30+	1974-75	1974 - 99
Virginia (CGN-38)	4	178.3 m (585 ft)	19.2 m (63 ft)	11,300	2 x D2G	60,000	30+	1976-80	1976 - 98
CGN-42				12,100			30+	Cancelled 1979	
CSGN				17,200			30+	Cancelled 1976	
CG(X)					1 x A1B		30+	Cancelled 2010	

CGN reactor compartments

U.S. cruiser have two reactors in separate, shielded reactor compartments located fore-and-aft in the hull. Approximate dimensions and weights are shown in the diagrams.

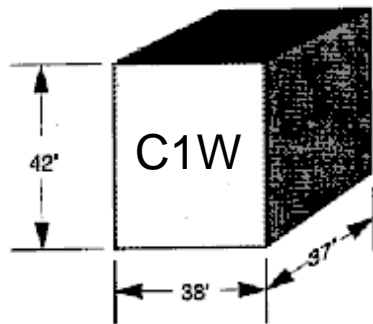

LONG BEACH
Cruiser - 2
(2250 tons)

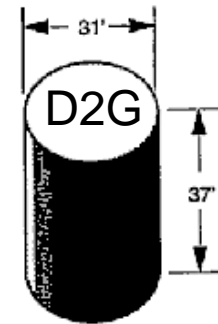

Cruisers other than
LONG BEACH - 16
(1400 tons)

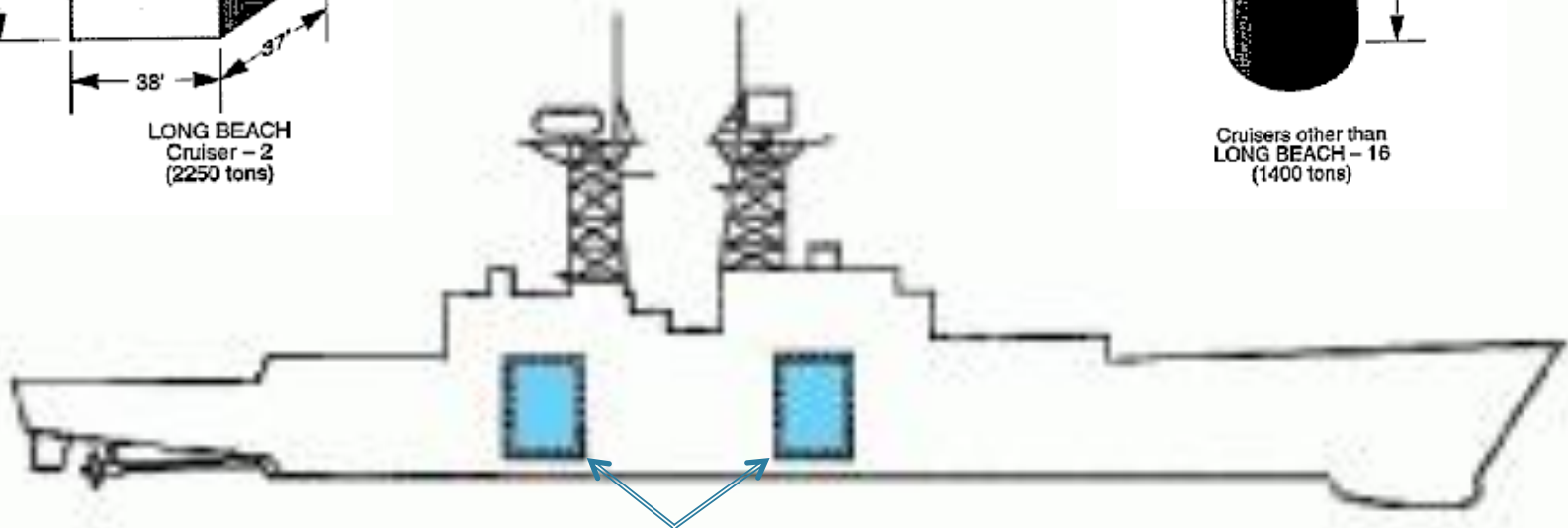

Two reactor compartments

Nuclear-powered cruisers



All six California- and Virginia-class nuclear-powered cruisers in a 1981 exercise, from left to right: *USS Texas* (CGN 39), *USS California* (CGN 36), *USS South Carolina* (CGN 37), *USS Virginia* (CGN 38), *USS Arkansas* (CGN 41), and bringing up the rear, *USS Mississippi* (CGN 40).

Source: U.S. Navy

USS Long Beach (CGN-9)

1st nuclear-powered cruiser & 1st U.S. nuclear-powered surface ship

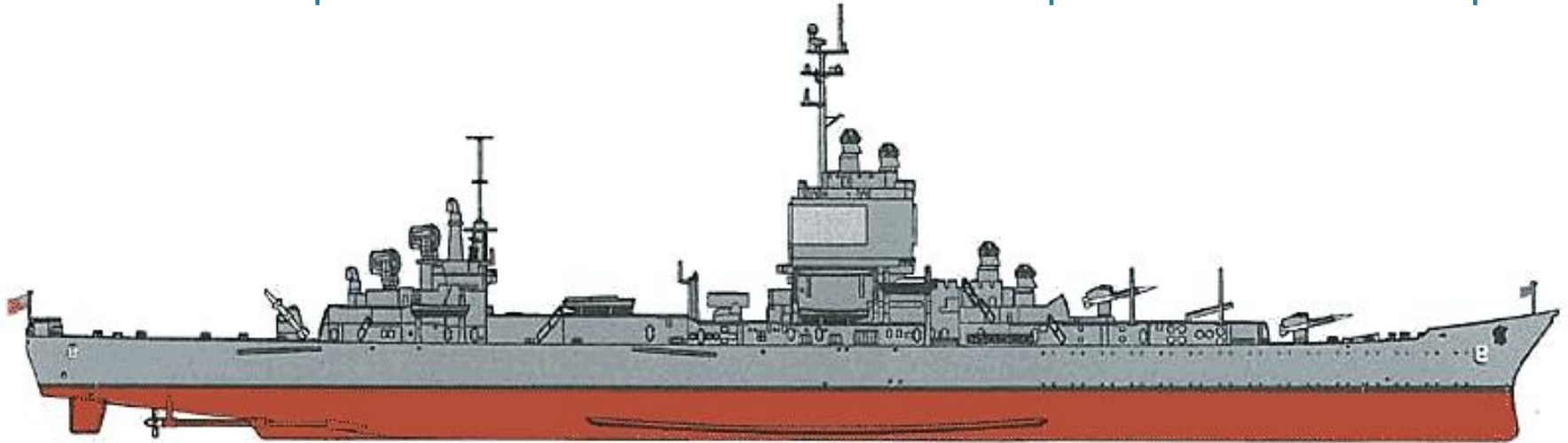

Source: The-Blueprints.com

- Built by Bethlehem Steel, Quincy, MA. Keel laid in Dec 1957; commissioned 9 Sep 1961
- Originally designed as an all-missile cruiser. Deck area behind the bridge superstructure originally was reserved for launching Regulus cruise missiles, and later for 4 x Polaris missile launch tubes, but neither was implemented.
- 5 July 1961: *USS Long Beach* underway on nuclear power
- Propulsion: 2 x C1W reactors each rated @ 200 MWt (est); 2 x steam turbines driving 2 x shafts; total propulsion power 80,000 hp (60 MW).
- *Long Beach* was refueled twice.
 - Cores 1 & 2 operated for an average of 9.5 years; Cores 3 operated for almost 14 years.
- Deactivated 2 July 1996; operating life 35 years.

USS Long Beach (CGN-9)

SCANFAR phased-array radars (AN/SPS-32 & -33) removed from bridge superstructure. These radars were the predecessors of the AN/SPY-1 phased array radars used on the later Aegis cruisers.

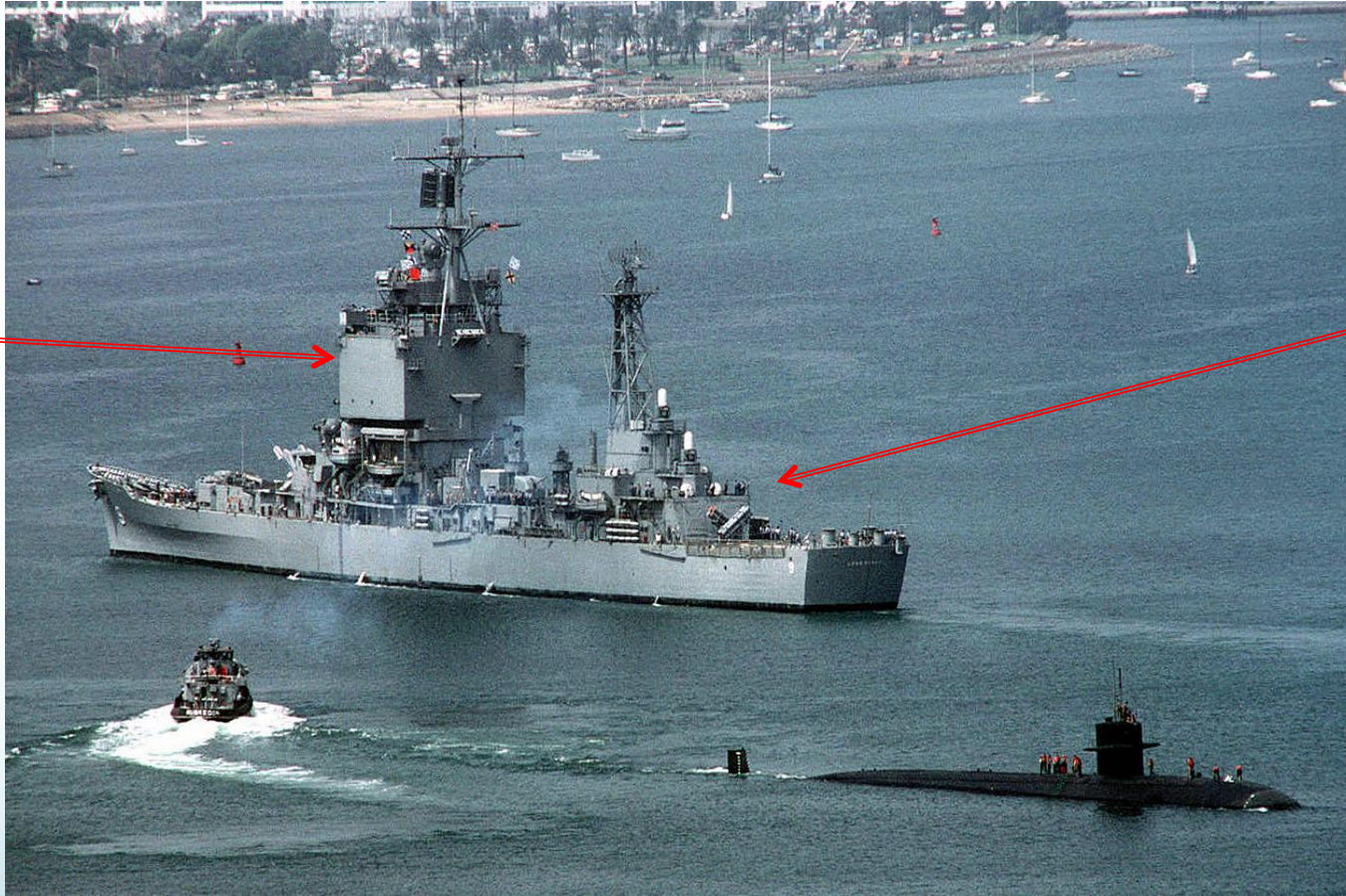

Aft Talos missile launcher removed, replaced by 2 x Harpoon launchers & 2 x Tomahawk box launchers & 2 x Phalanx CIWS

USS Long Beach & USS La Jolla in San Diego Bay

Source: www.reddit.com/r/WarshipPorn/comments

USS Bainbridge & USS Truxtun

USS Bainbridge (CGN-25)

Source: www.militaryart.com



USS Truxtun (CGN-35)

Source: www.militaryart.com



USS Bainbridge & USS Truxtun

- *Bainbridge* (CGN-25) was a modified conventionally-powered Leahy-class guided missile frigate built by Bethlehem Steel, Quincy, MA
- *Truxtun* (CGN-35) was a modified conventionally-powered Belknap-class guided missile frigate built by New York Shipbuilding, Camden, NJ
- Both ships originally were classified as guided missile “destroyer leaders,” (DLGN) and re-classified as guided missile cruisers (CGN) in 1975.
- Propulsion: 2 x D2G reactors, each rated @ 148 MWt; 2 x steam turbines delivering a total of 60,000 hp (45 MW) to 2 x shafts
- Operational matters:
 - 31 Jul – 3 Oct 1964: As a member of the all-nuclear Task Force One, *USS Bainbridge* participated in *Operation Sea Orbit*, along with *USS Enterprise* (CVN-65) and *USS Long Beach* (CGN-9), and circumnavigated the globe in 65 days without refueling or replenishment
 - *Bainbridge* refueled three times and *Truxtun* refueled twice; each time with longer-life cores:
 - 1st cores: 5 – 6.5 years; last cores: 13 years
 - Operating life: *Bainbridge* 34 years; *Truxtun* 28 years.

CGN-36 California-class cruisers

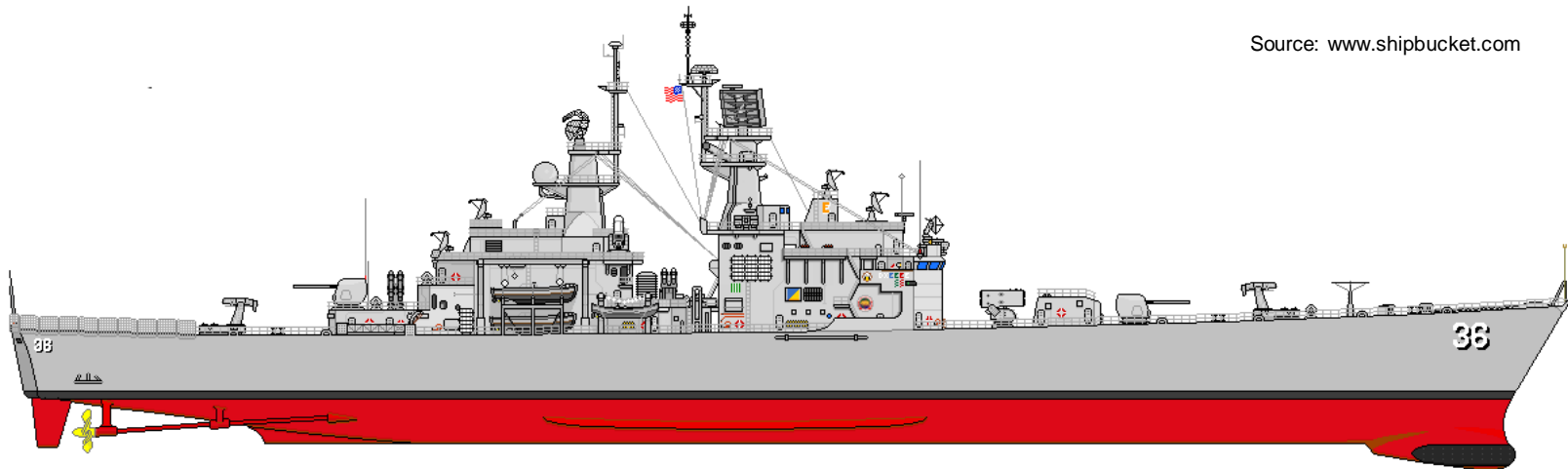

- Two ships in this class, built by Newport News Shipbuilding.
- These were larger cruisers than *Bainbridge / Truxtun*, with more comprehensive anti-air and anti-sub capabilities.
- Propulsion: 2 x D2G reactors, each originally rated @ 148 MWt; 2 x steam turbines delivering a total of 60,000 hp (45 MW) to 2 x shafts
 - Both ships underwent a mid-life overhaul + refueling in the early 1990s, intended to give them a further 18 - 20 years of active service.
 - The original 148 MW D2G reactors were replaced by 165 MW D2W reactor cores
 - Operating life for both ships on core 1: 16 years

CGN-36 California-class cruisers

- Operational matters:
 - Mid-life overhauls improved anti-air capabilities (limited to handling the RIM-66 Standard Missile SM-2MR), but deactivated the bow sonar and deleted ASROC anti-sub weapons.
 - Apr 1990 – Jan 1993: *USS California* overhaul & refueling; cost \$425 million
 - Mar 1991 – Mar 1994: *USS South Carolina* overhaul & refueling
 - By 1998, California-class cruisers cost about \$38.8 million annually to man, operate, and maintain. A typical conventionally-powered CG-47 Ticonderoga-class cruiser cost about \$29.5 million annually.
 - California-class cruiser crew size was about 600, including costly nuclear-trained crew. CG-47 Ticonderoga-class cruisers carry fewer than 400 crew.
 - California-class ships lacked significant capabilities found on CG-47
 - No helicopter hangars or anti-submarine warfare weapons
 - Not capable of handling the more advanced anti-air missiles used on Aegis cruisers: RIM-161 Standard Missile 3
 - Both ships were decommissioned in 1999. Operating life was 24 – 25 years.

CGN-38 Virginia-class cruisers

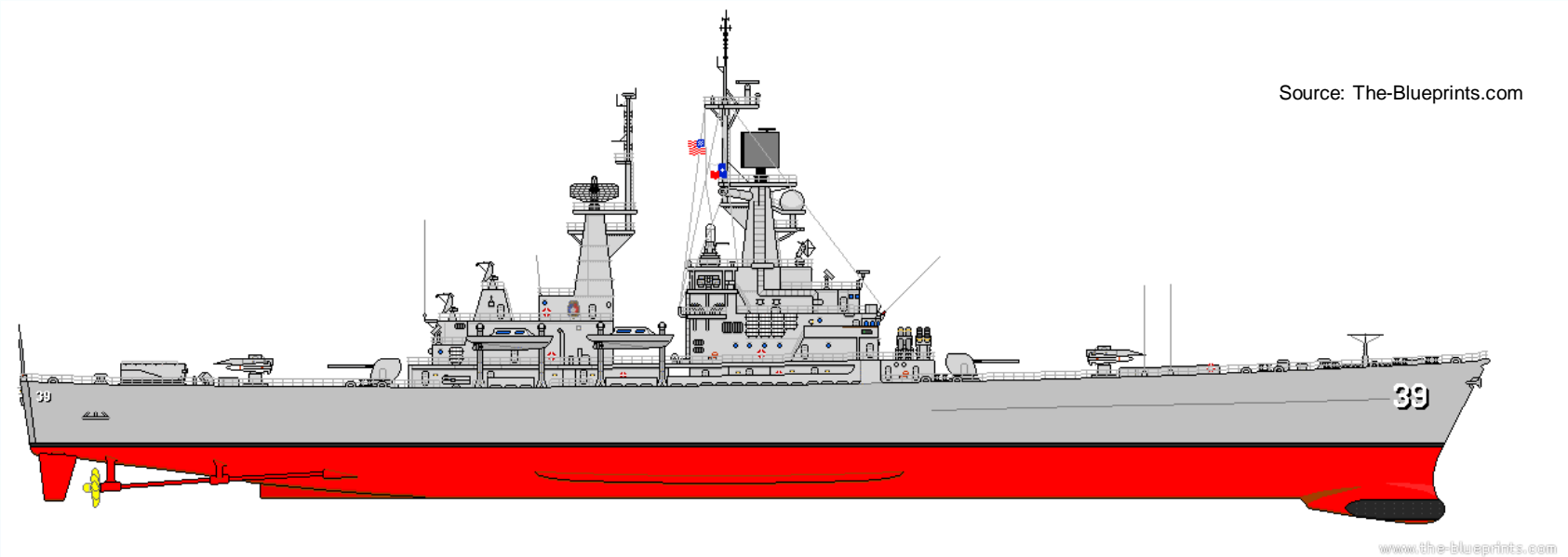

- Four ships in this class built by Newport News Shipbuilding.
- Comparable in size and capabilities to the CGN-36 California-class cruisers.
- Propulsion: 2 x D2G reactors, each rated @ 148 MWt; 2 x steam turbines delivering a total of 60,000 hp (45 MW) to 2 x shafts
- Navy originally planned to procure 11 ships of the CGN-38 Virginia-class.
 - After four units of the Virginia-class had been laid down, further orders were suspended while consideration was given to a Modified Virginia design (CGN-42) and a Strike Cruiser (CSGN), both fitted with the Aegis combat system

CGN-38 Virginia-class cruisers

- In 1993 the Navy cancelled mid-life refueling overhauls for Virginia-class cruisers and all were retired early later in the decade.
- The 1996 *Navy Visibility and Management of Operating and Support Costs (VAMOSOC)* study determined the annual operating cost of a Virginia-class cruiser at \$40 million, compared to \$28 million for a conventionally-powered CG-47 Ticonderoga-class cruiser, or \$20 million for a DDG-51 Arleigh Burke-class destroyer, both of which carried the modern Aegis Combat System.
- All four Virginia-class CGNs were decommissioned between 1994 - 99. Operating life was 16 - 19 years.



Source:
https://en.wikipedia.org/wiki/Virginia-class_cruiser

CGN-42 and the CSGN Strike Cruiser

CGN-42

- A derivative of the Virginia-class (CGN-38) plus the addition of the Aegis combat system
- 12,100-ton
- CGN-42 was estimated to have a unit procurement cost of about \$1.34 billion (1981 dollars); 30% - 50% greater than a CG-47 conventionally-powered Aegis cruiser.
 - CGN-42 procurement cost includes the cost of the 1st D2G cores.
- FY1978 budget included advance procurement of nuclear components and engineering.
- Project officially cancelled in 1979

CSGN

- New hull design, unspecified nuclear propulsion plant plus the Aegis combat system
- 17,200-ton
- CSGN was estimated to have a unit procurement cost in the range of \$1.8 – 2.1 billion; about double that of a CG-47 conventionally-powered Aegis cruiser.
 - CSGN procurement cost includes the cost of the 1st reactor cores.
- In 1976 the Senate Armed Services Committee completely deleted the Navy's request for the nuclear-powered strike cruiser

CGN-42 concept drawings

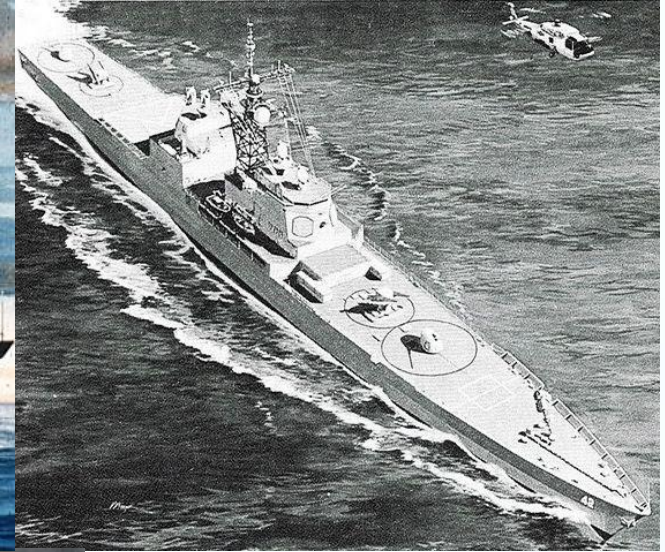

Left:
Proposed CGN-42
compared to CG-47
Ticonderoga-class
cruiser

CSGN concept drawings



Source: <http://www5e.biglobe.ne.jp/~vandy-1/csgn.htm>

CGN-42 & CSGN concept comparison

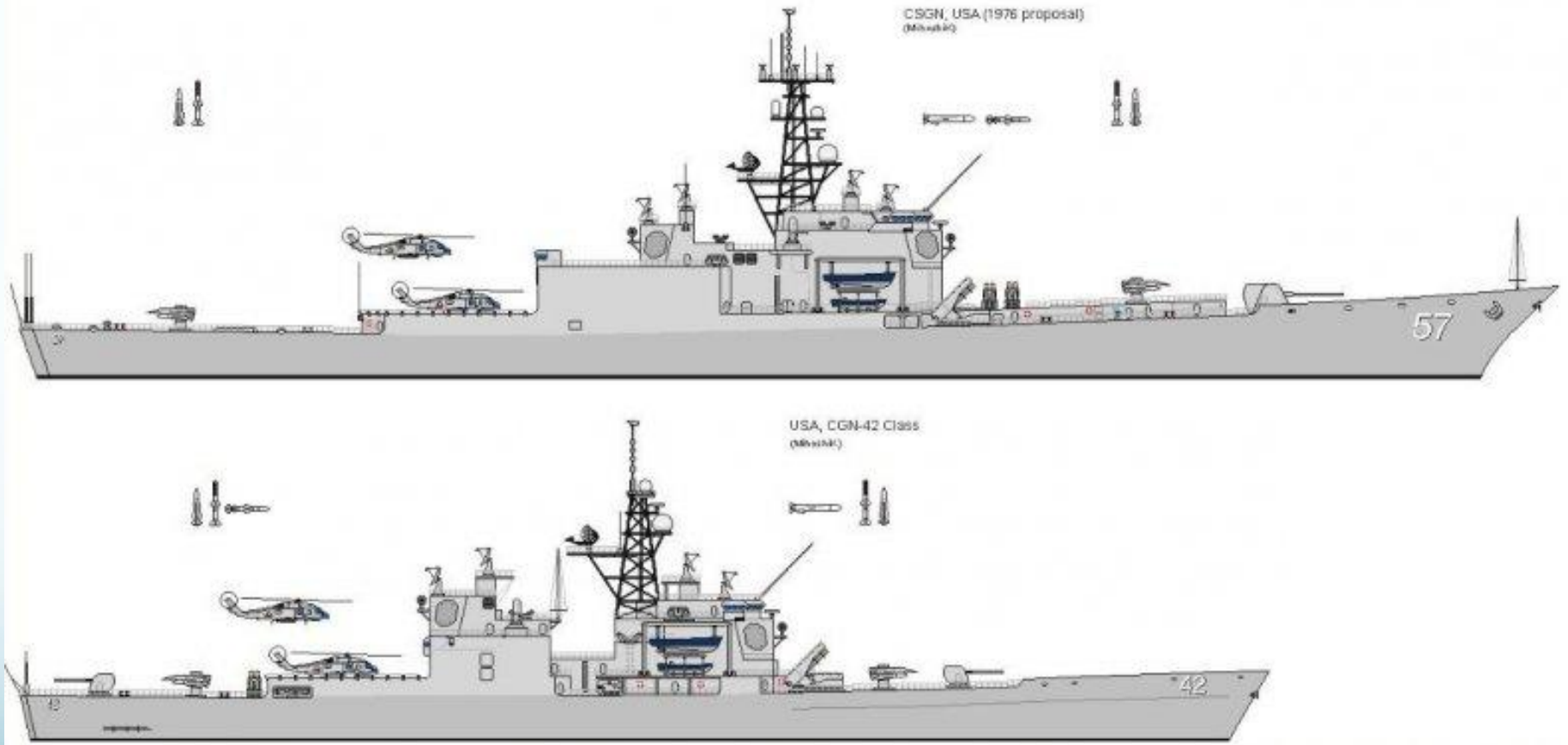

CG(X) next generation cruiser

CG(X) might have looked like a DDG-1000



Source: [https://en.wikipedia.org/wiki/CG\(X\)](https://en.wikipedia.org/wiki/CG(X))

- Intended as the replacement for CG-47 Ticonderoga-class Aegis cruisers, with planned procurement starting in 2017.
- CG(X) would have had the powerful Air and Missile Defense Radar (AMDR)
 - The Navy reported the power requirement of the CG(X) combat system, including radar, to be 30 - 31 MWe, compared with about 5 MWe for the CG-47 Aegis combat system.
 - CG(X) originally was intended to share the DDG-1000 hull.
 - CG(X) was to have a total electric power-generating capacity of about 80 MWe.
- A nuclear-powered version of the CG(X) was considered by the Navy.
 - Reactor choice was not announced, but, if the hull were large enough, could have been a single A1B PWR (i.e., one-half of the propulsion plant of a Ford-class carrier).
 - The initial reactor likely would be sufficient to power a CG(X) for its entire service life of 30 to 35 years.
 - A nuclear-powered CG(X) was estimated to cost 32 - 37% more than a conventionally powered CG(X)
 - The Navy never announced if it preferred to build CG(X) as a nuclear-powered ship.
- The CG(X) program was cancelled in 2010.
 - The Navy funded conventionally-powered DDG-51 Flight III in the FY2011 budget

Nuclear-powered aircraft carriers

Class	# in Class	Length	Beam	Displacement (tons)	Reactor	Shaft (hp)	Max speed (kts)	Years delivered	Years in service
Enterprise (CVN-65)	1	342.3 m (1123 ft)	40.5 m (132.8 ft) (waterline) 78.4 m (257.2 ft)(max)	94,781	8 x A2W	280,000	33.6	1962	1962 - 2012
Nimitz (CVN-68)	10	332.8 m (1092 ft)	40.8 m (134 ft) (waterline) 76.8 m (252 ft) (max)	101,600 – 106,300	2 x A4W	260,000	30+	1975 - 2009	1975 - present
Ford (CVN-78)	3 (plan)	337.1 m (1106 ft)	40.8 m (134 ft) (waterline) 78.0 m (256 ft) (max)	100,000	2 x A1B	260,000	30+	2016 (plan)	

- For this class of ship, the primary benefits of nuclear power are:
 - Independence from the need to refuel, enabling high-speed deployment over long distances and long on-station time.
 - No ship's exhaust gas interfering with flight operations and causing corrosion problems for the ship and aircraft.
 - Greater storage capacity for aviation fuel and weapons to support air operations between replenishments.

	USS Constellation (CVA-64)	USS Nimitz (CVN-68)
Endurance	12,000 mi @ 20 kts	unlimited
Aviation fuel	6,500 tons	9,180 tons
Aviation ordnance	1,800 tons	2,970 tons

Role of the aircraft carrier

- 1948 “Key West Agreement” assigned nuclear warfare roles to U.S. military branches, including missile roles:
 - Air Force – Strategic bombers & ICBM
 - Army – IRBM
 - Navy – No defined ballistic missile role, but preserved the separate Naval aviation role. The aircraft carrier was essential for a Navy nuclear warfare role.
- 1949: Secretary of Defense cancelled Navy’s 1st “supercarrier,” *USS United States* (CVA-58), in favor of the Air Force B-36 strategic bomber. This led to the “revolt of the admirals.”
 - Ambitions Navy plans for nuclear attack aircraft defined in Outline Specification 111 also were scaled back.
- The 1950 – 53 Korean War confirmed the importance of carriers in conventional warfare.
- *USS Forrestal* (CV-59), the lead ship in the first class of modern “supercarriers,” was ordered in 1951. The later nuclear-powered carriers, *USS Enterprise* and the Nimitz-class, evolved from the *Forrestal* design.

USS Enterprise (CVN-65) & *USS Robert E Lee* (SSBN-601)

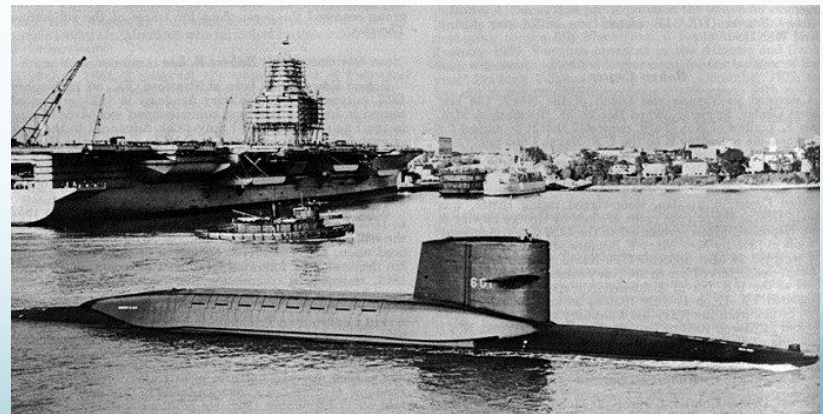

Source: navsource.com

Role of the aircraft carrier

- Introduction of the Fleet Ballistic Missile (FBM) sub in 1960 challenged the carrier's role as a nuclear attack platform.
- Sep 91 GHW Bush Presidential Nuclear Initiative: Orders all tactical nuclear weapons removed from Navy ships
 - Affects aircraft carriers, other surface combatants, and submarines.
 - A carrier battle group no longer carries offensive tactical or defensive nuclear weapons.
- An aircraft carriers operates in a battle group (also known as a Carrier Strike Groups, CSG) with other ships that are intended to defend the carrier against attack.
 - Other than its embarked air wings, a carrier is lightly armed and is not able to put up a strong defense against attack.
 - Carrier battle group elements vary, but typically include:
 - The nuclear-powered aircraft carrier with its embarked air wing with 60 – 70 aircraft,
 - At least one Aegis guided missile cruiser,
 - A destroyer squadron with at least two Arleigh Burke-class guided missile destroyers,
 - Up to two fast attack nuclear submarines (SSN), and
 - A combined ammunition, oiler & supply ship; usually a Supply-class T-AOE.
 - The carrier battle group trains and deploys as a team with well-established, integrated tactics.

Role of the aircraft carrier

- Modern, precision-guided anti-ship cruise and ballistic missiles, submarines, and anti-aircraft defenses are making aircraft carriers and their embarked air wings increasingly vulnerable to attack. For example:
 - A full salvo of 24 supersonic anti-ship cruise missiles from a single Russian Oscar-class SSGN may overwhelm the defense capabilities of a carrier battle group.
 - These subs are being updated to carry 72 cruise missiles, which will represent an even greater challenge to a carrier battle group.
 - Access to the South China Sea could become an issue for any U.S. military vessels in a time of conflict, due to the presence of Chinese DF-21D anti-ship ballistic missiles with a range of 900 miles (1,448 km).
 - The Pentagon calls this an anti-access/area denial (A2/AD) challenge.

Replenishment at sea

Supply-class fast combat support ships (T-AOEs) travel with carrier battle groups to refuel, rearm & restock ships in the battle group.



Source: <http://www.defense.gov/Photos>



Source: <http://cimsec.org>

T-AOEs have a max. speed of 25 kts and are the only Navy resupply ships able to keep up with a carrier battle group.

In 2014, the Navy was considering retiring the T-AOEs and replacing battle group service with 20 kt oilers and dry cargo ships.

USS Enterprise (CVN-65)

1st nuclear-powered aircraft carrier

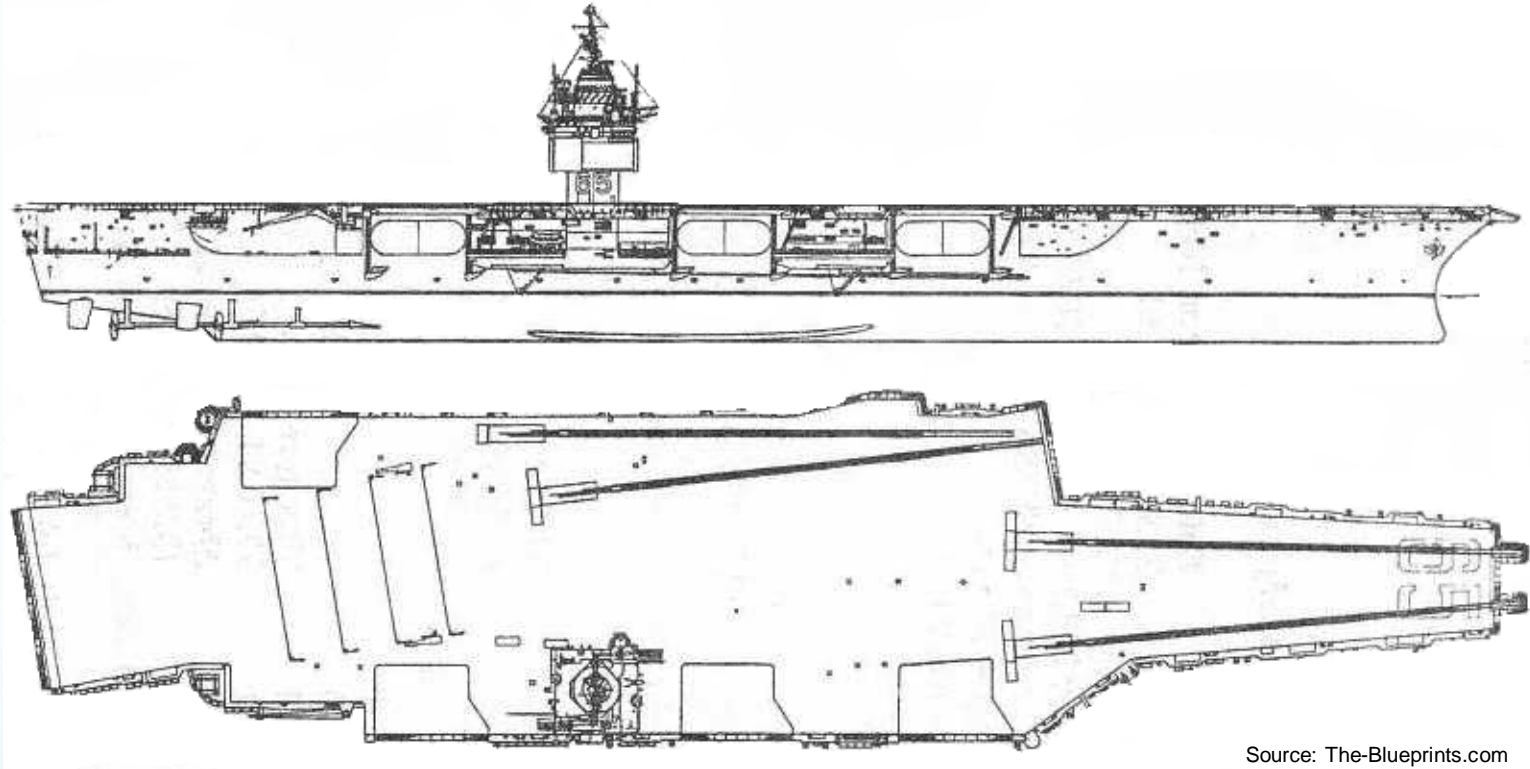

Source: The-Blueprints.com

- Keel laid in 4 Feb 1958; commissioned 25 Nov 1961
- Propulsion: 8 x A2W reactors each rated @ 150 MWt (est); 4 x steam turbines driving 4 x shafts; total propulsion power 280,000 hp (210 MW). Also supplies steam for catapults.
- Enterprise's reactors were refueled three times as part of complex overhauls.
 - Cores 1 & 2 operated for an average of 3 years; Cores 3 & 4 operated for an average of 18.9 years
- Decommissioned 1 Dec 2012; operating life 51 years.

Operation Sea Orbit

Source: US Navy



On 31 July 1964 the all-nuclear Task Force One, comprised of U.S. Navy warships *USS Enterprise* (CVN-65), *USS Long Beach* (CGN-9), and *USS Bainbridge* (DLGN-25, later CGN-25), commenced a global cruise, Operation Sea Orbit, circumnavigating the globe without refueling or replenishment.

Task Force One spent 65 days deployed, with 57 of them at sea, and steamed 30,216 miles (48,628 km). Average speed while underway was about 22 kts.

Rear Admiral Streaun noted that the flexibility of operating a force of nuclear powered vessels meant that TF1 "could have been diverted to any other maritime area of the world without logistical considerations and could have been ready for immediate operations upon arrival."



Enterprise's career lasted 51 years, being decommissioned in 2012.

Source: <https://www.sinodefenceforum.com>

CVN-68 Nimitz-class

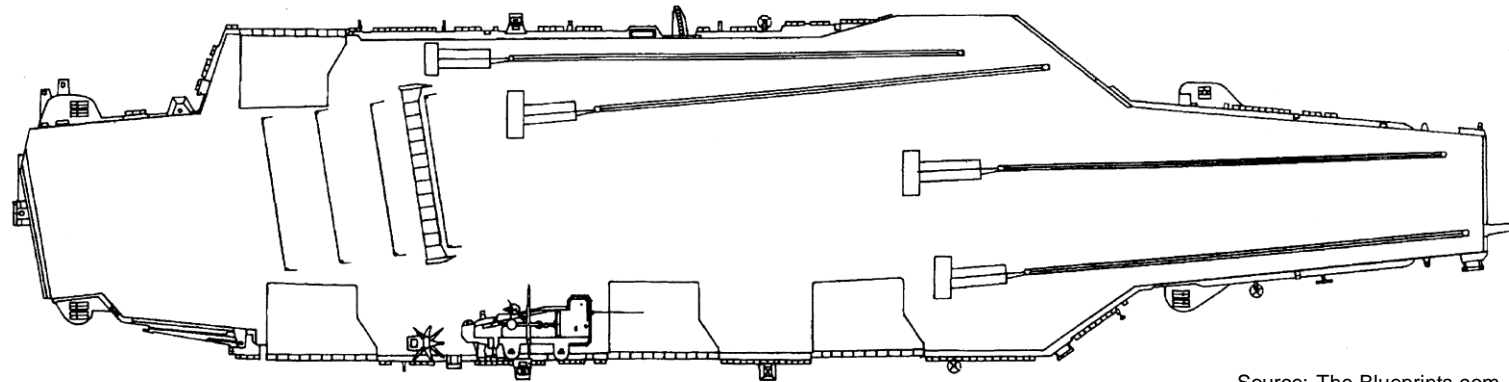
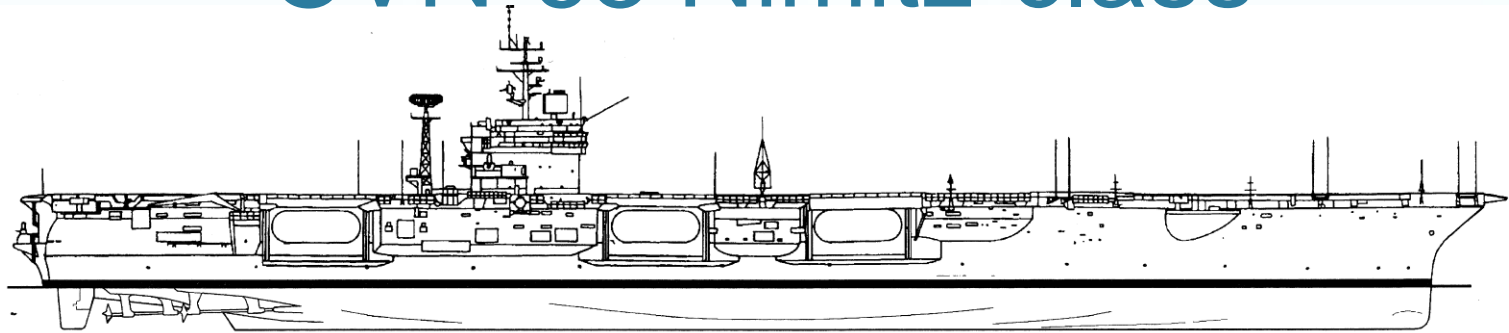

Source: The-Blueprints.com

- Ten Nimitz-class aircraft carriers were commissioned between 1975 - 2009.
- Propulsion & electric power: 2 x A4W PWRs, each rated @ 550 MWt; 1,100 MWt total.
 - 4 x steam turbines driving 4 x shafts; total propulsion power 260,000 hp (194 MW).
 - The secondary steam plants also supply steam for the aircraft catapults.
 - 8 x steam turbine-generators producing 8 MWe each, for a total generating capacity of 64 MWe.

CVN-68 Nimitz-class

- Armament:
 - Embarked air wing: typically 85–90 fixed-wing aircraft and helicopters.
 - The CVNs, themselves, have only modest close-in anti-air armament (varies from ship to ship): Sea Sparrow, Rolling Airframe Missile (RAM), Phalanx 20 mm cannons.
 - CVNs depend on other ships in the Carrier Battle Group as their primary means of anti-air/missile & anti-submarine defense.
- Operational matters:
 - Operating life is planned to be 49 years, with one 3-year mid-life refueling + complex overhaul that typically takes place after 23 – 24 years of service.
 - As of mid-2015, mid-life refueling + complex overhauls have been completed on four ships (CVN-68 to -71) and one is in progress (CVN-72).
 - The first Nimitz-class carrier (*USS Nimitz*) is scheduled to be decommissioned in 2024, and the last (*USS George HW Bush*) in 2058.
 - The earlier Nimitz-class ships each cost about \$4.5 billion. Almost 30 years later, the last ship (*Bush*) cost about \$6.2 billion.

CVN-78 Gerald R. Ford-class

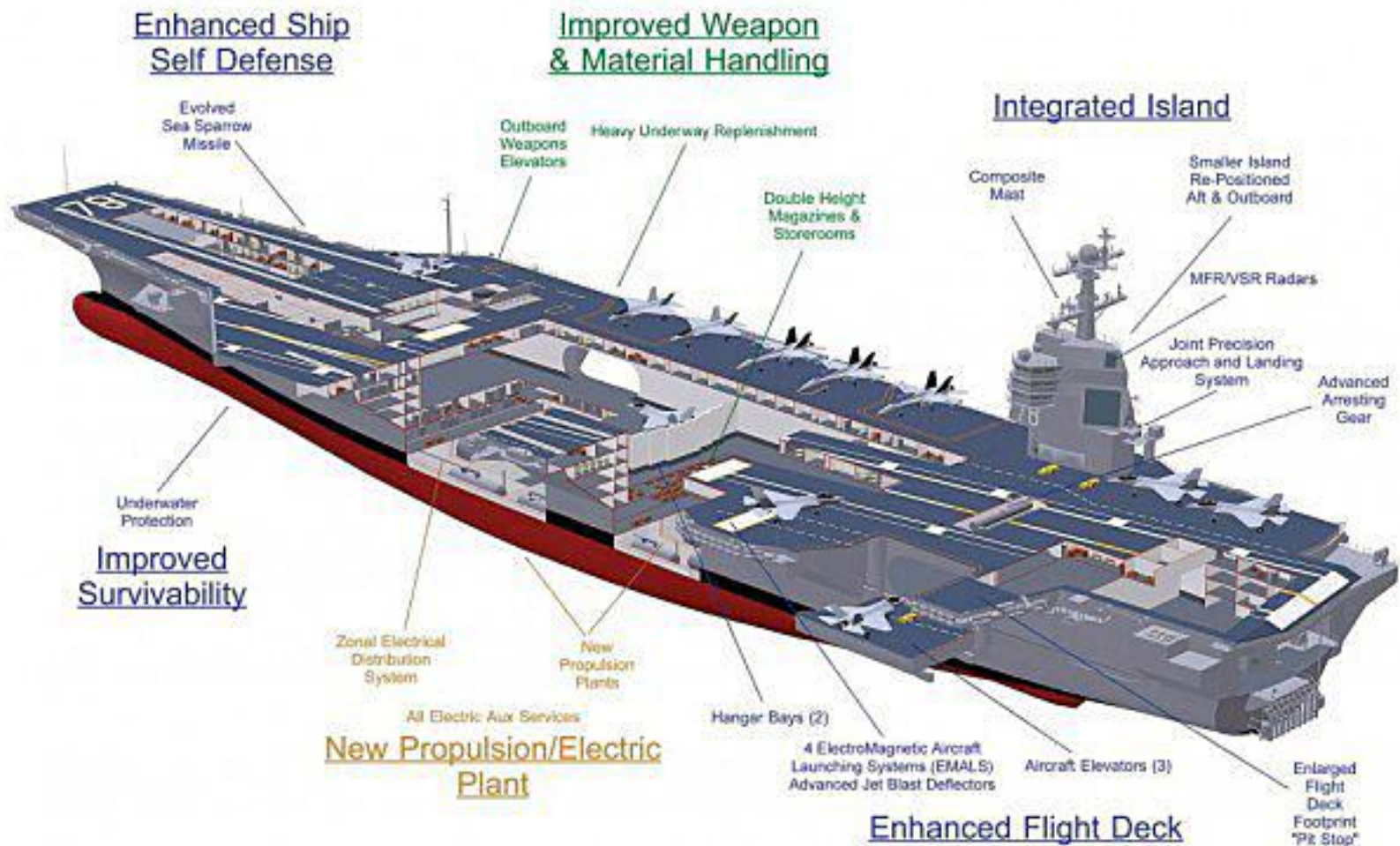

CVN-78 Gerald R. Ford-class

- Ford-class carriers are expected to replace the *USS Enterprise (CVN-65)*, which retired in 2012, and the 10 Nimitz-class aircraft carriers, to restore the Navy to its Congressionally-mandated fleet of 11 carriers.
- Propulsion and electric power: 2 x A1B PWR. Reactor power rating is not known, but is expected to be greater than the 550 MWt A4W reactors used in Nimitz-class carriers.
 - 4 x steam turbines driving 4 x shafts; total propulsion power 260,000 hp (194 MW); same as Nimitz-class
 - Electric power generating capacity of about 300 MWe; more than 4 times the 64 MWe generating capacity of Nimitz-class CVNs
- Lead ship, CVN-78, is expected to be commissioned in 2016. The Navy's FY2016 estimate of the ship's procurement cost is about \$12.9 billion.
- First deployment may not occur until 2020 to allow time for shock tests (live munitions exploded in the water close to the ship).



Source: <http://news.usni.org/2015/09/10/>

Nuclear vessel decommissioning and environmental cleanup

U.S. Navy's Nuclear Ship & Submarine Recycling Program (NSSRP)

- Defueling can be carried out at any of five ship repair facilities on the U.S. West Coast.
 - Reusable ship's equipment also is removed at this time.
 - After fuel has been removed, the hulls are classified as low-level radioactive waste.
 - Spent fuel is shipped by rail to Naval Reactors Facility (NRF) at Idaho National Laboratory (INL) where the fuel is stored in special canisters.



Source: <http://snakeriveralliance.org/nuclear-navys-final-port-of-call/>

U.S. Navy's Nuclear Ship & Submarine Recycling Program (NSSRP)

- The hulls are then towed to Puget Sound Naval Shipyard (PSNS) and kept in “afloat storage” until they can be moved to Drydock 1, where the vessel is cut into 3 or 4 sections: bow, missile, reactor, stern.
- Missile compartments of FBM subs are dismantled according to the provisions of the Strategic Arms Reductions Treaty.
- Reactor compartment of each vessel is removed and sealed with welded steel bulkheads.
- By the end of 2011, the reactor compartments of 114 submarines and 8 cruisers have been processed.
- Until 1991, the forward and aft sections of the submarines were rejoined and placed in floating storage.
- Since 1991, hazardous and toxic material in the remaining submarine sections are cleaned, usable equipment is recycled, and the balance is scrapped.

Four Lafayette class (SSBN-616) in the early stages of being scrapped at PSNS in 1993



Source: <http://barthworks.com/submarine/>

Subs awaiting processing by NSSRP in 2015

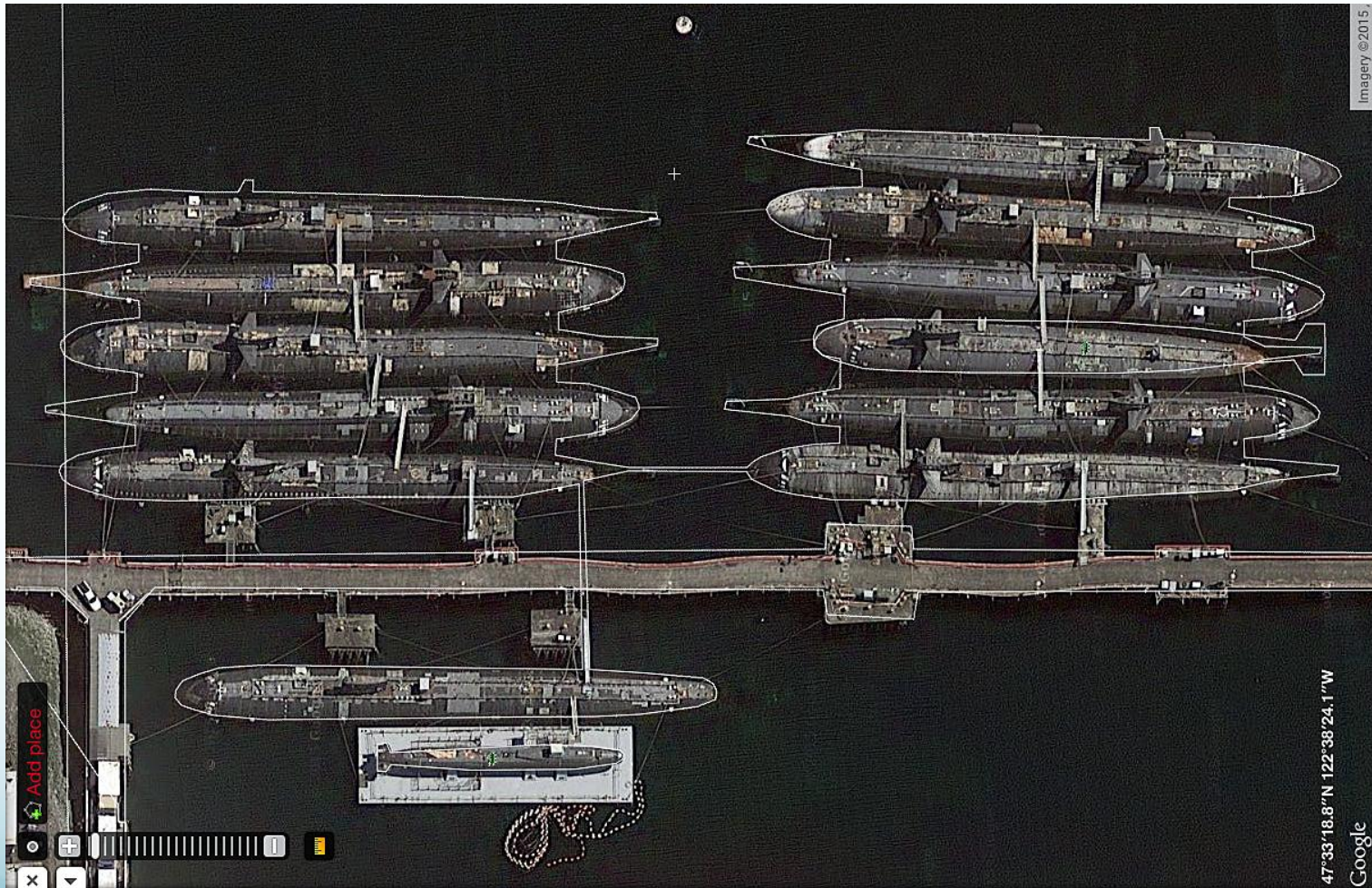

11 x Los Angeles (688)-class Flight I subs, USS Narwhal (SSN-671), and NR-1 (on the floating platform).

Source:
wikimapia.org/1823114/SRP-Fleet

U.S. Navy's Nuclear Ship & Submarine Recycling Program (NSSRP)

- Then the sealed reactor compartment is shipped by barge down the coast and along the Columbia River to the port of Benton.
- There the hull section is transferred to a special multi-wheeled, high-load trailer and transported by road to the Hanford Nuclear Reservation, where they currently are kept in dry, open storage in engineered burial trenches that eventually will be covered (Trench 94, 200 Area East).
 - The sealed hull sections and burial trenches are designed for long-term safe storage
- Disposal of a submarine by this process costs the Navy \$25 – 50 million.



Source: <http://barthworks.com/submarine/>



Spent fuel management at NRF



**Transport SNF
from ship to ECF**



**Upload Shipping
Container**



Process in Water Pools



**Await transport to an
Interim Storage Facility
or a Geologic Repository**



Package for Disposal



U.S. civilian nuclear marine applications

- Bulk cargo + passenger vessel
- Floating nuclear power plant
- Other U.S. commercial marine reactor designs

Savannah

U.S. prototype civilian bulk cargo + passenger vessel

- Launched: July 1959; initial criticality: 21 Dec 1961; delivered March 1962 to Maritime Administration
- Designed to carry 60 passengers & 124 crew + 8,500 tons of bulk cargo
- Length OA: 596 ft; beam 78 ft; full load displacement: 22,000 tons
- Reactor:
 - 74 MWt, 2 x loop PWR designed by Babcock & Wilcox
 - Core life: 6 years (core 1)
 - Reactor located amidship, inside a steel containment vessel
 - Fuel: UO_2 pellets in stainless steel rods; two enrichment zones: 4.2% & 4.6%; 164 fuel rods per fuel element; 34 fuel elements in a stainless steel grid structure.
- Propulsion:
 - Steam turbine, 22,000 hp, driving a single shaft; speed: 22 kts
 - Backup propulsion using 2 x diesel generator driving a 750 hp electric motor geared to the main shaft



Source: https://en.wikipedia.org/wiki/NS_Savannah

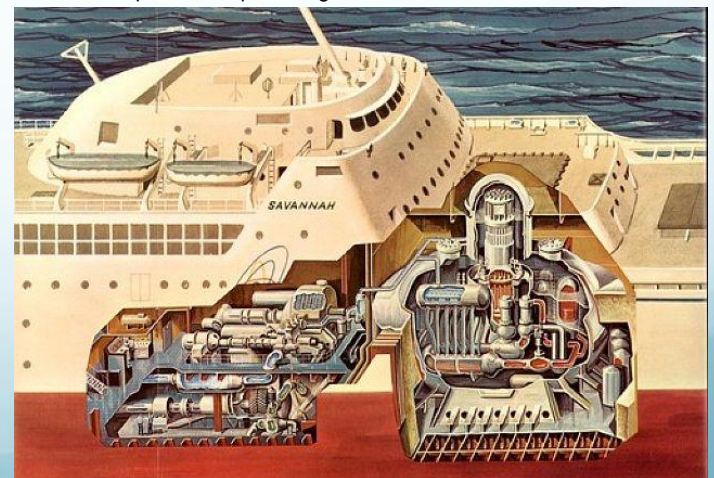

Source: http://www.nssavannah.net/gallery.php?PCat_ID=3

Savannah

- Operational matters

- 20 Aug 1962 – 1971: Domestic & international voyages; cruising 450,000 miles on nuclear power.
- 10 Jan 1972: Laid up in Savannah, GA.
- 1975: Reactor de-fuelled in Galveston. However, Maritime Administration did not fund complete decommissioning and removal of other nuclear components.
- 1982: Savannah was designated as a National Historical Landmark.
- 1981 – 1994: On display at Patriots Point Naval & Maritime Museum in Charleston, then various movements for drydock repairs and storage.
- Now dockside in Baltimore in a state of “maintained storage”; awaiting funding for decommissioning and possible future role as a museum ship.



NS Savannah, 2015

Savannah Primary System

mockup

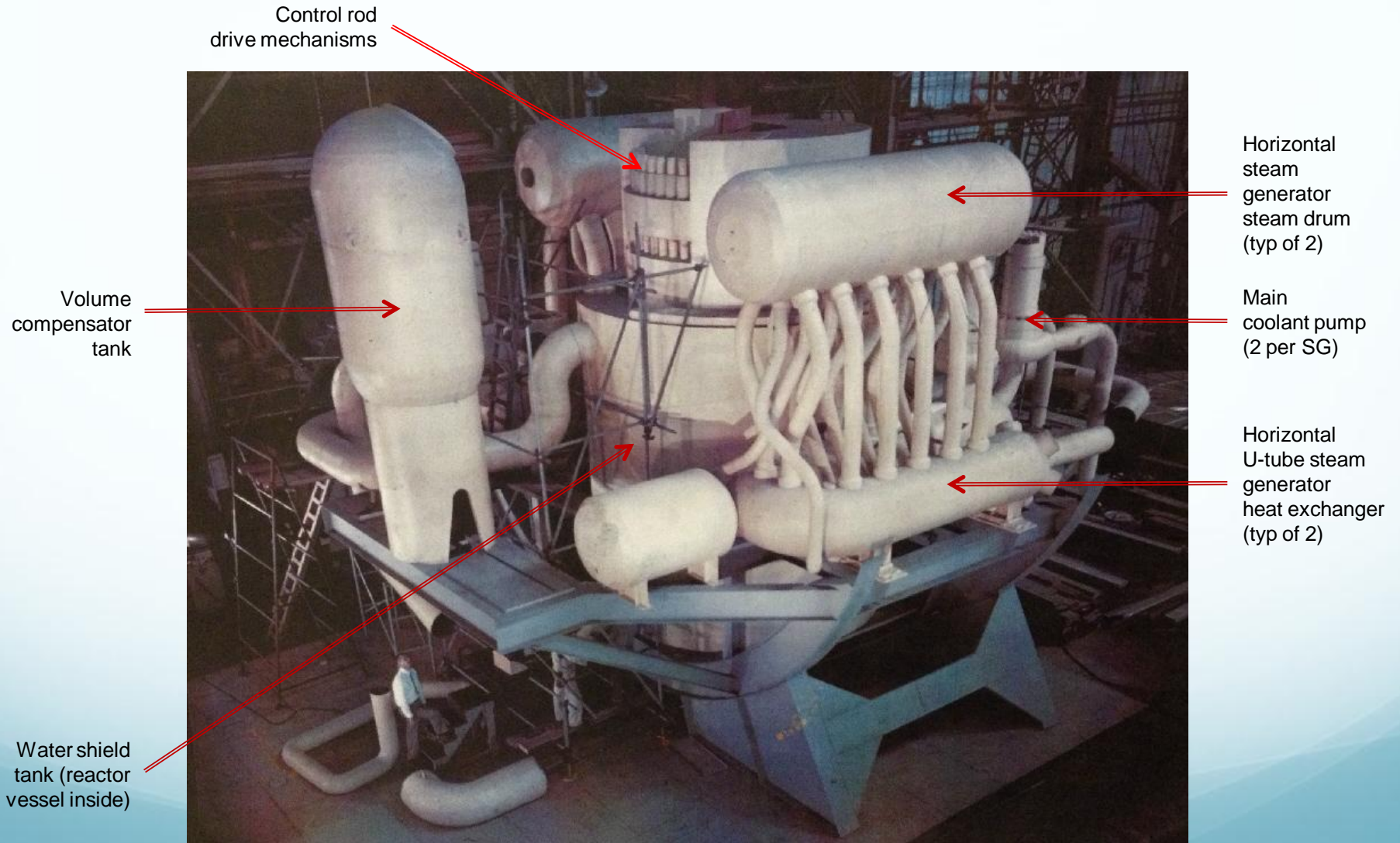

Savannah Reactor

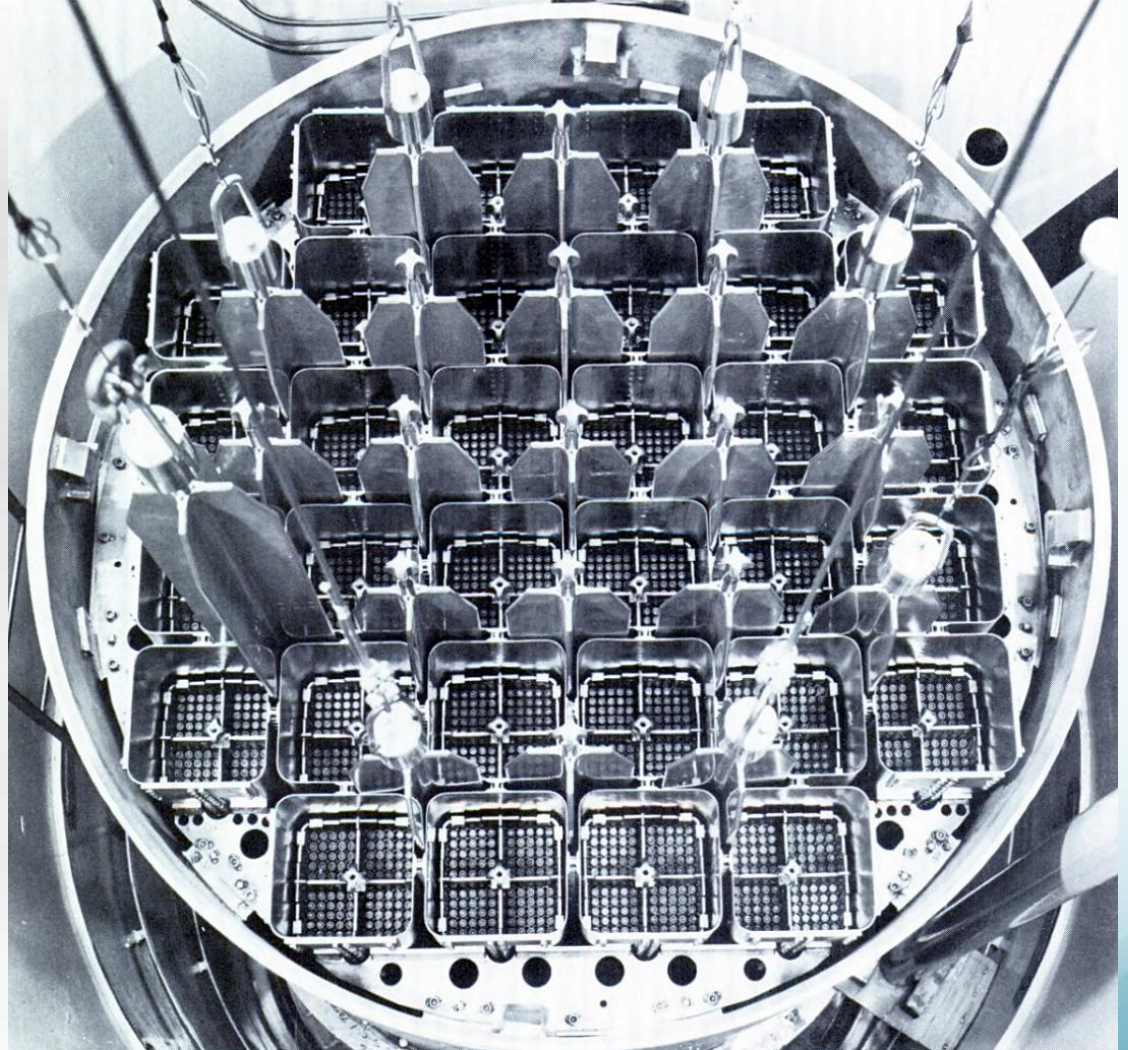
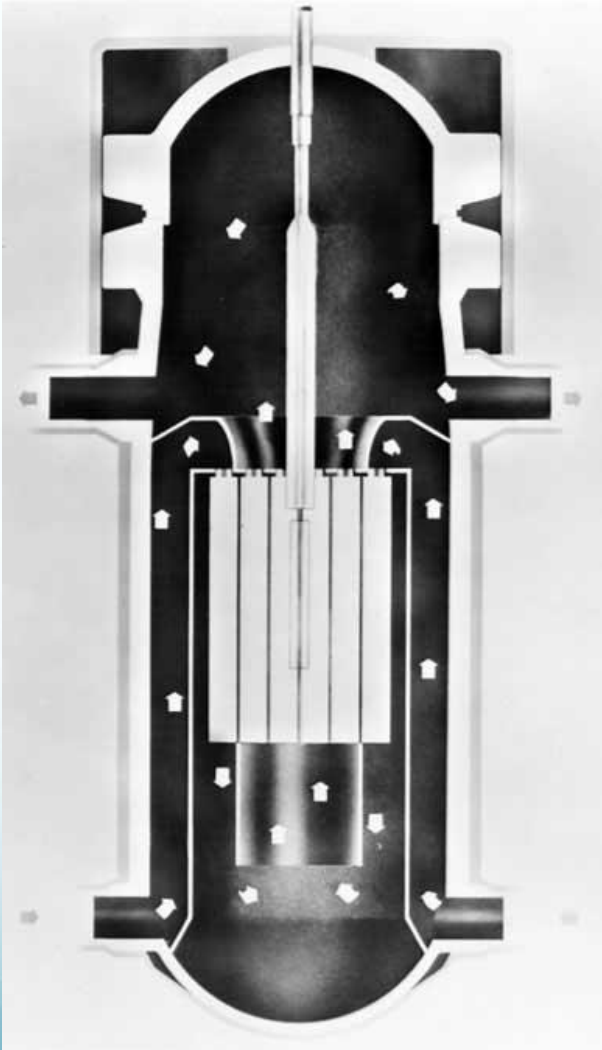

Source: <http://www.maritime.org/tour/savannah>

Savannah Reactor Control Room



Savannah Reactor Control Room

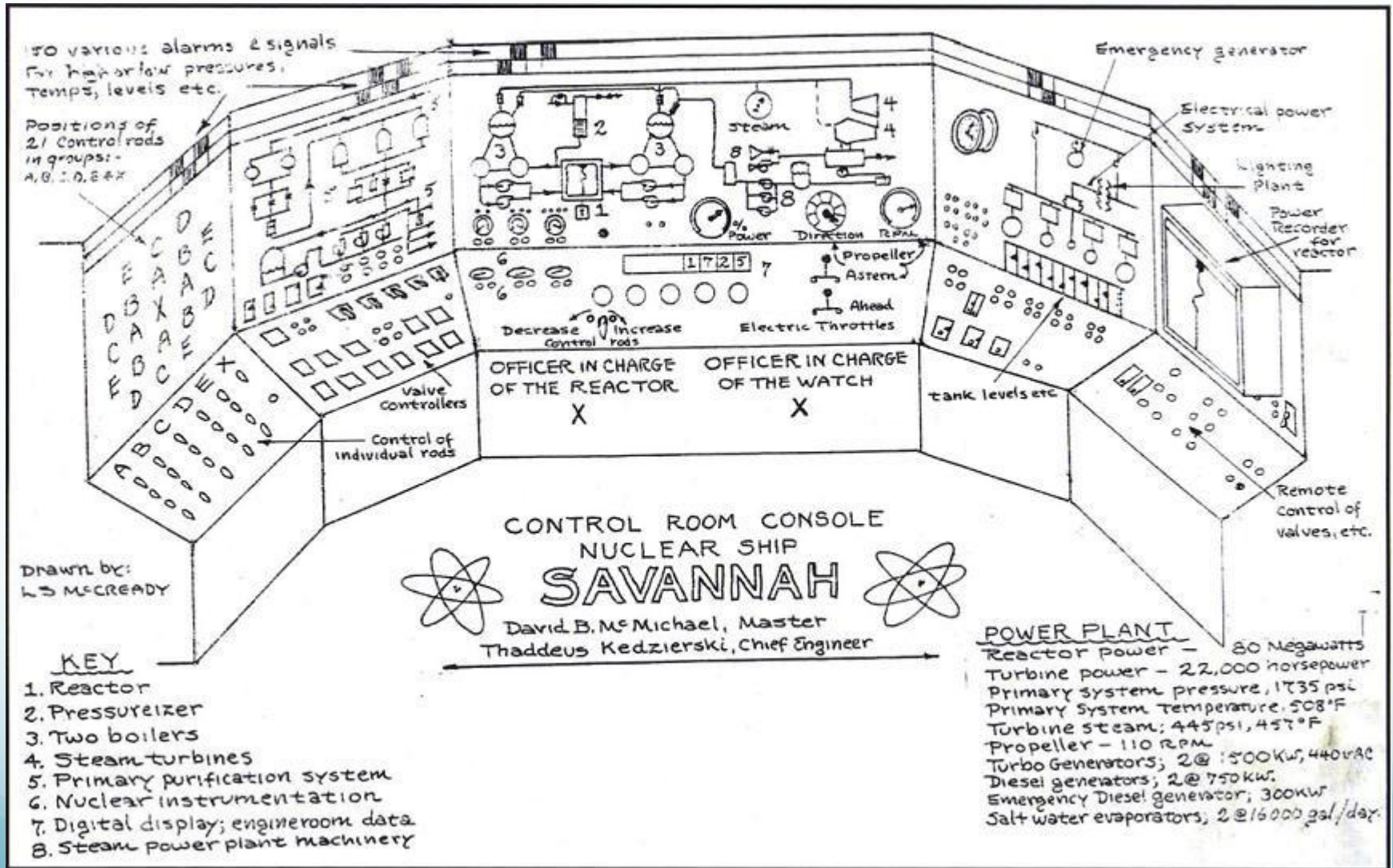

Savannah public areas



Above: Reception area
Below: Restaurant

Gene Roddenberry was a passenger. Did he get the idea for the the Star Trek badge from this bar table?

Sturgis

U.S. floating nuclear power plant

- Built on the hull of WW II Liberty ship *Charles G. Cogle*, with a new mid-section inserted between the bow and stern.
 - Designed as a towed craft; it was intended to stay dockside, connected to the shore power infrastructure when the reactor was operating
 - The new mid-section included heavy radiation shielding and collision protection for the nuclear plant
- Length OA: 441 ft; beam 56 ft; displacement: 14,500 tons (approx.)

Sturgis with electrical switchgear on the bow



Source: http://www.shipmodels.info/mws_forum/

- Reactor:
 - Mobile, High-power, 1st-of-a-kind (MH-1A) developed under the Army Nuclear Program by Martin Marietta; this was the largest and last of the Army's small reactors
 - 45 MWt, 10 MWe, single-loop PWR
 - Fuel: UO_2 pellets in stainless steel rods, two enrichments: 5.0 & 5.4%
 - Core: 10 x 10 rods per fuel element; 34 fuel elements; 2-zone core
 - Reactor located amidship, inside a 360 ton steel containment vessel
 - 1st refueling Oct 1969; MH-1A used five cores during its 8-year operational life.

Sturgis

U.S. floating nuclear power plant

- Operation:
 - *Sturgis* arrived at Fort Belvoir for installation of the reactor on April 1966; initial criticality 24 Jan 1967 followed by 1-yr testing
 - Towed to Panama Canal, arriving Aug 1968. Then provided power to the Panama Canal Zone grid from 1968 to 1975, replacing the output of Gatun Hydroelectric Plant. This allowed more water from Gatun Lake to be available to fill canal locks, enabling 2,500 more ships per year to pass through the canal.
 - Retired due to high cost of operation and end of the U.S. Army's nuclear power mission; returned to U.S. in Dec 1976, defueled in June 1977.
 - Contract for *Sturgis* decommissioning awarded Apr 2014; to be completed in 2016.



Sturgis moored alongside Savannah awaiting decommissioning

Source: http://www.nnaprentice.com/alumni/letter/STURGIS_MH_1A.pdf

MH-1A installation on Sturgis

U.S. floating nuclear power plant

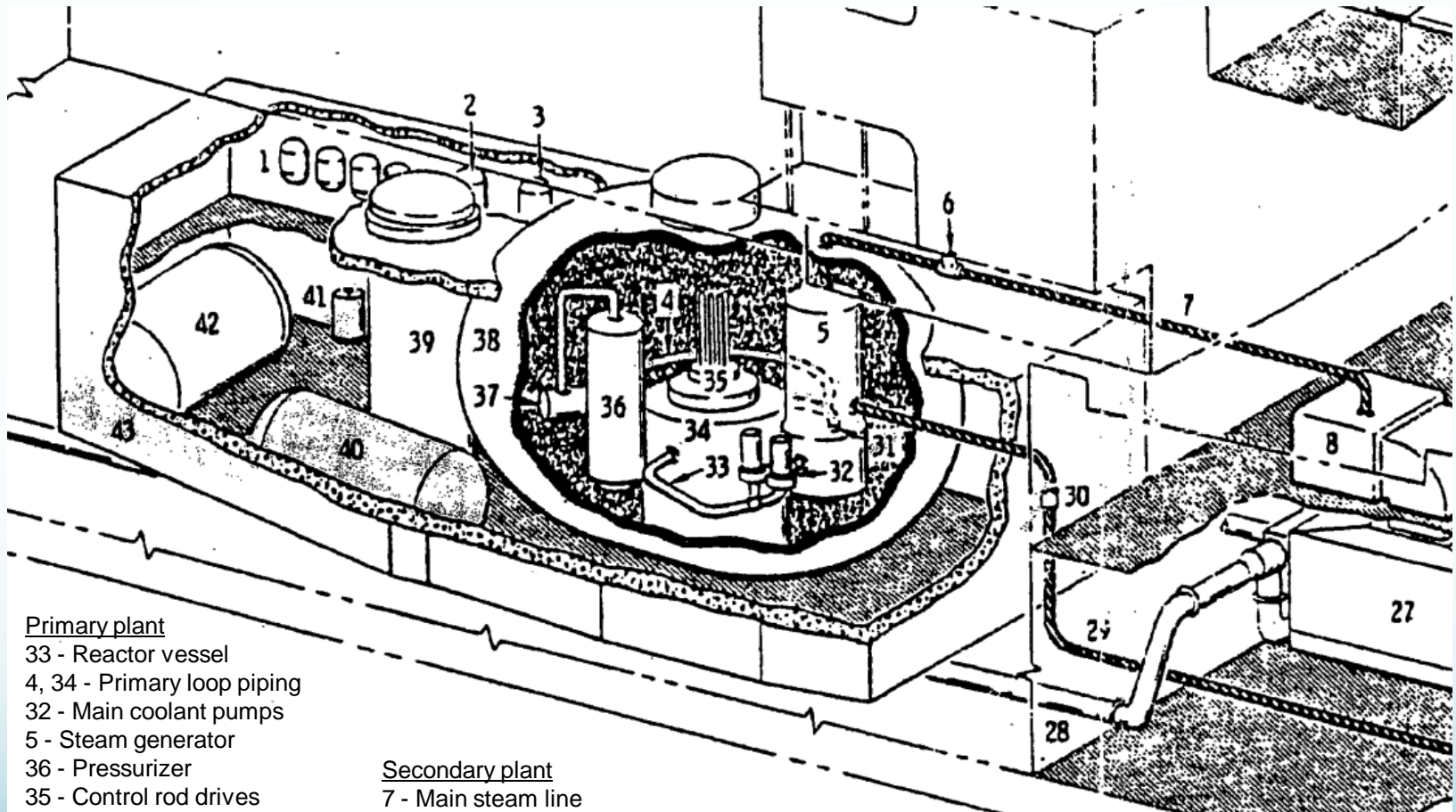

Primary plant

- 33 - Reactor vessel
- 4, 34 - Primary loop piping
- 32 - Main coolant pumps
- 5 - Steam generator
- 36 - Pressurizer
- 35 - Control rod drives

Secondary plant

- 7 - Main steam line
- 8 - Turbine generator
- 27 - Main condenser
- 29 - Main feedwater line
- 28 - Main cooling water line

Containment structures

- 38 - Containment vessel
- 29 - Spent fuel storage tank

TIMELINE FOR THE MH-1A AND STURGIS



US Army Corps of Engineers®

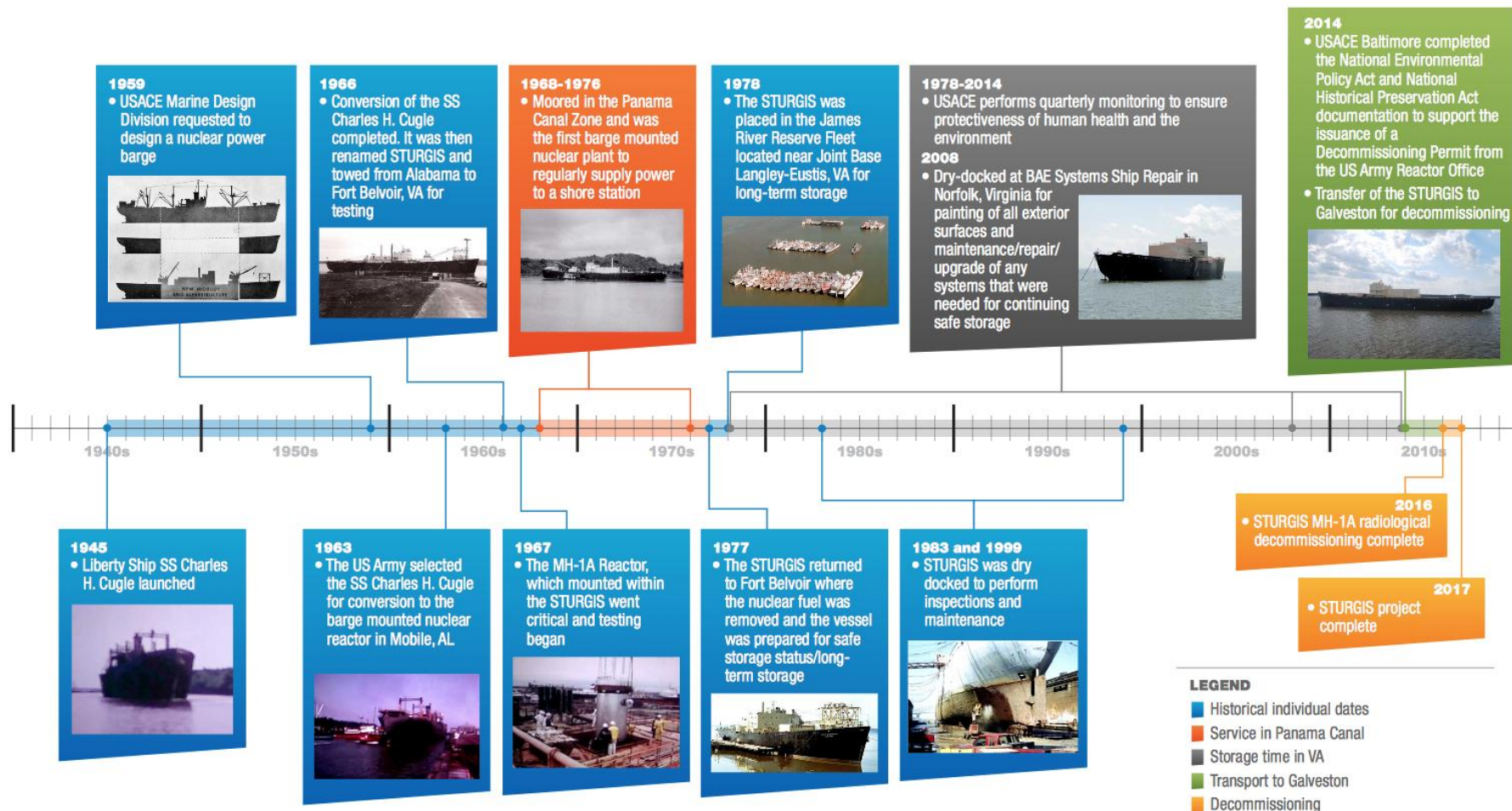

PROPOSED ACTION



US Army Corps of Engineers®

Babcock & Wilcox Marine Reactor

Consolidated Nuclear Steam Generator (CNSG)

- CNSG is a compact, integral pressurized water reactor (PWR) plant. The reactor, once-through steam generators, and pumps are all housed in a single primary vessel.
- **CNSG I, 38 MWt, 1961**
 - UO₂ pellets, 3.5% and 6.6% enrichment in Zr-4 fuel rods
 - Pumps at bottom of vessel
 - Dry containment
 - Used on German vessel Otto Hahn
 - Built by B&W–Interatom consortium
 - Reactor began operation in 1968; refueled in 1972; decommissioned in 1979
- **CNSG II, 184 MWt, 1963**
 - Core raised to mid-vessel
 - Control rods enter the core from the bottom
 - Low-enriched UO₂ fuel
 - Wet containment
 - Pumps at the top of the vessel
- **CNSG II, 313 - 365 MWt, 1976**
 - Core moved back to the bottom of the vessel
 - Control rods enter the core from the top
 - Pumps at the top of the vessel
 - U.S. Maritime Commission sponsored a 313 MWt version targeted for propelling a 600,000 ton tanker
 - DOE (then ERDA) sponsored a 365 MWt land-based version capable of delivering 91 MWe.
 - A design for a barge-mounted version of CNSG III was developed, providing either electrical or steam output to on-shore users.
- **CNSS (Consolidated Nuclear Steam Supply), 1,200 MWt, 1978**
 - The CNSS is the result of a B&W study of a CNSG III design extrapolated to 1,200 MWt.
 - CNSS was expected to deliver 400 MWe.
- The CNSG and CNSS design principles can be found today in the mPower small modular, land-based reactor being developed by B&W.

Babcock & Wilcox CNSG

CNSG I, 38 MWt, 1961

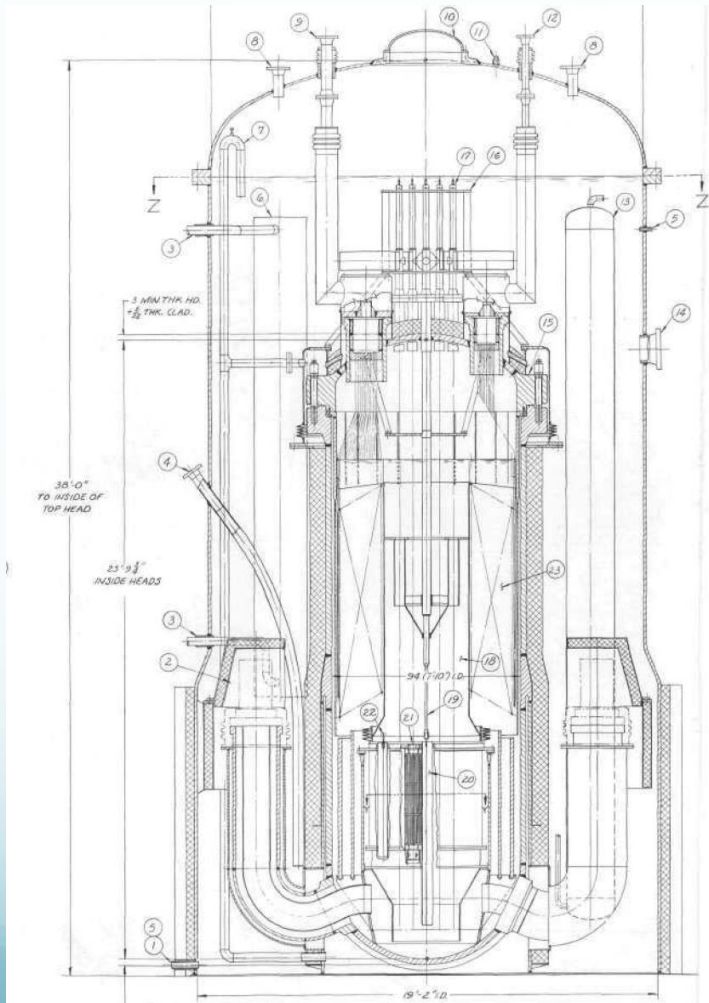

CNSG II, 184 MWt, 1963

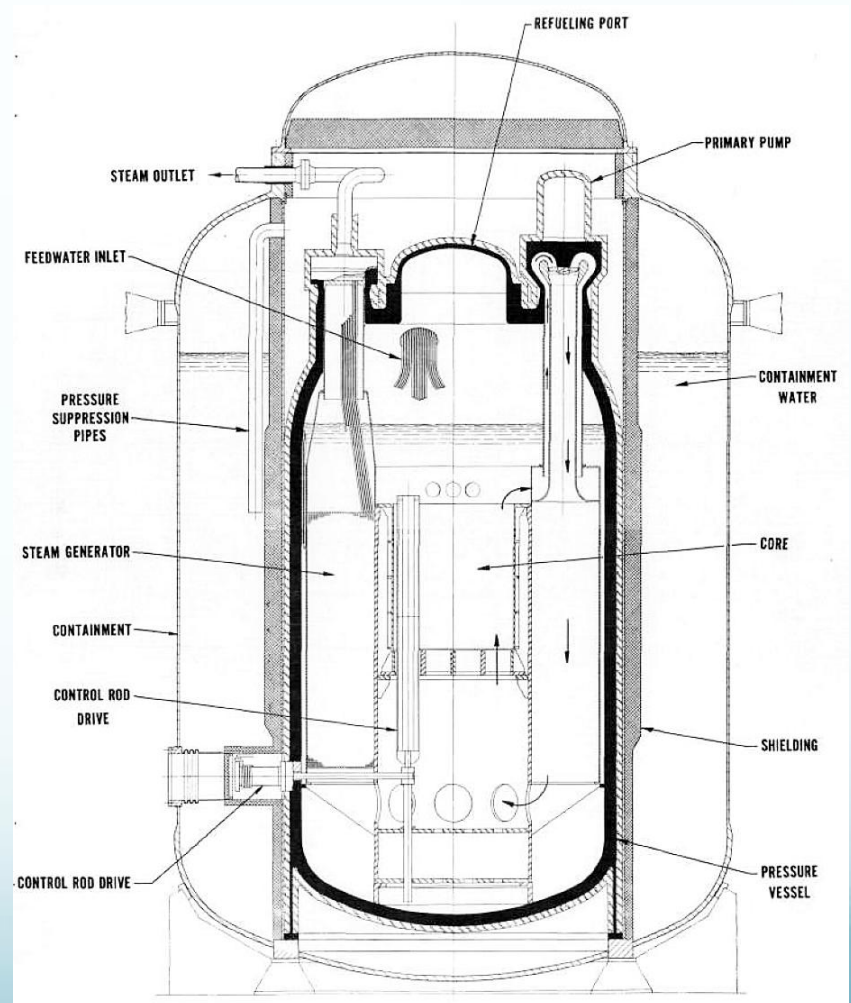

Source, two pictures: B&W Report 1280, 1963

Babcock & Wilcox CNSG & CNSS

CNSG III, 313 - 365 MWt, 1976

CNSS, 1,200 MWt, 1978

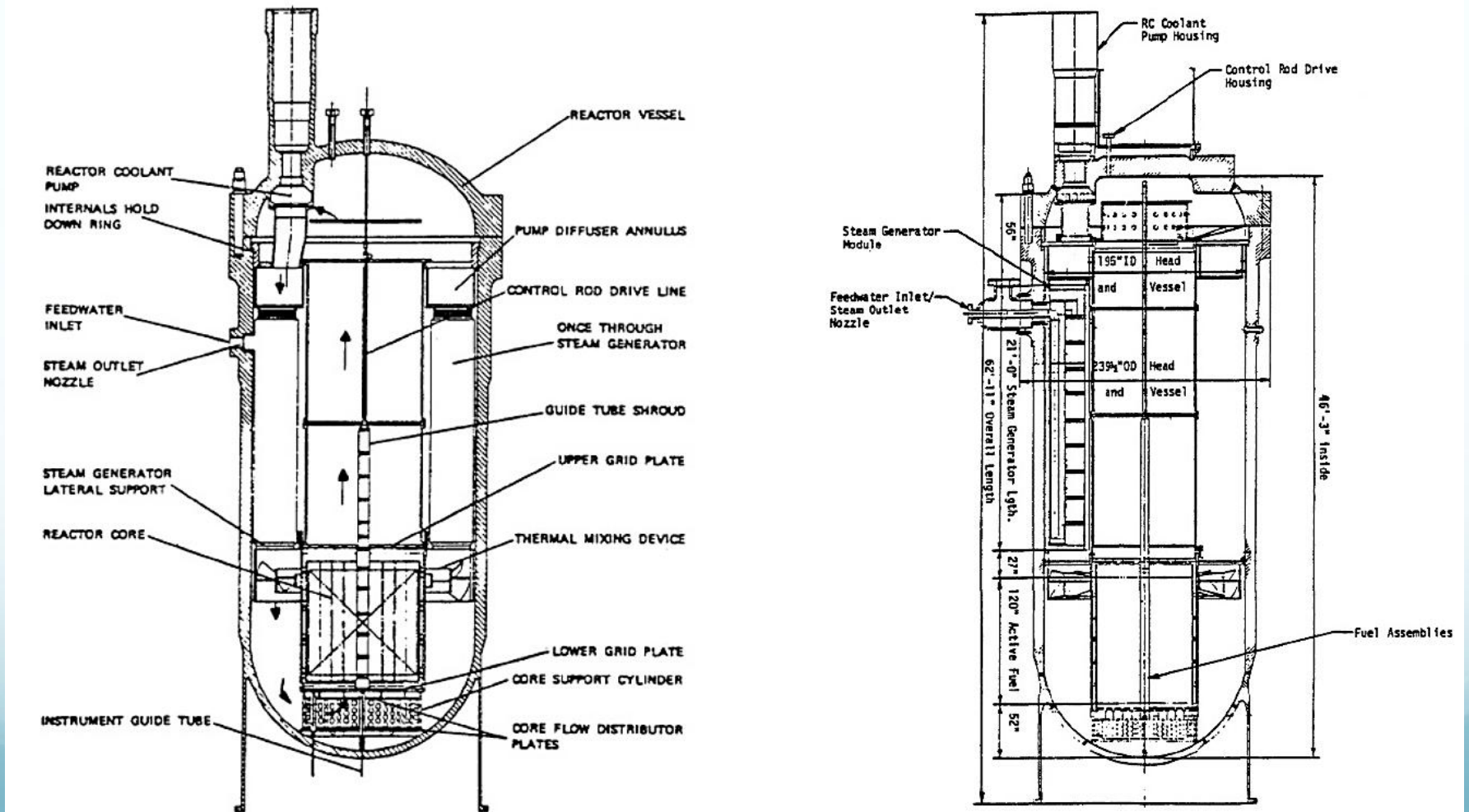

General Electric Marine Reactor

630A Nuclear Steam Generator

- In 1961, General Electric began design work on a maritime gas-cooled reactor based on their work on the Air Force Aircraft Nuclear Propulsion Program (ANPP).
- The 630A was a nuclear steam generator-superheater about the same size and somewhat heavier than a conventional marine boiler, which it could replace in merchant ships.
 - It has a gas primary circuit, transferring heat from the reactor to a once-through boiler-superheater. Feedwater delivered to the boiler is discharged as high superheated steam (1500 psi; 1000 F). Power conversion was by conventional steam turbo-machinery.
 - By 1965, the 630A had gone through five design iterations:
 - The first three 630A design concepts, Mark I, II and III, were all closed-cycle air-cooled reactors with concentric fuel rings using highly-enriched U-235.
 - Mark IV used either air or helium as the primary coolant, the core was smaller, but of similar design to the earlier models and used highly-enriched U-235, and gas circulators were enclosed entirely within the primary loop.
 - Mark V utilized all the features of the Mark IV except that the reactor used low-enrichment, pin-type fuel elements.
- In 1964, the former SL-1 facility at INL was evaluated as a site for testing a 630A prototype.
- The program was cancelled in about 1965.

General Electric 630A Nuclear Steam Generator

- Reactor power: 66 MWt
- Helium or air coolant (two versions) in the later versions
- Primary system conditions: 400 psig, core outlet temperature 1,200 °F
- Gas circulators
- Main steam conditions: 1,500 psig and 1,000°F
- Intended to deliver 27,300 shp propulsion power
- Module height: 38.25 ft
- Module diameter 19.67 ft
- Module weight: < 560 tons

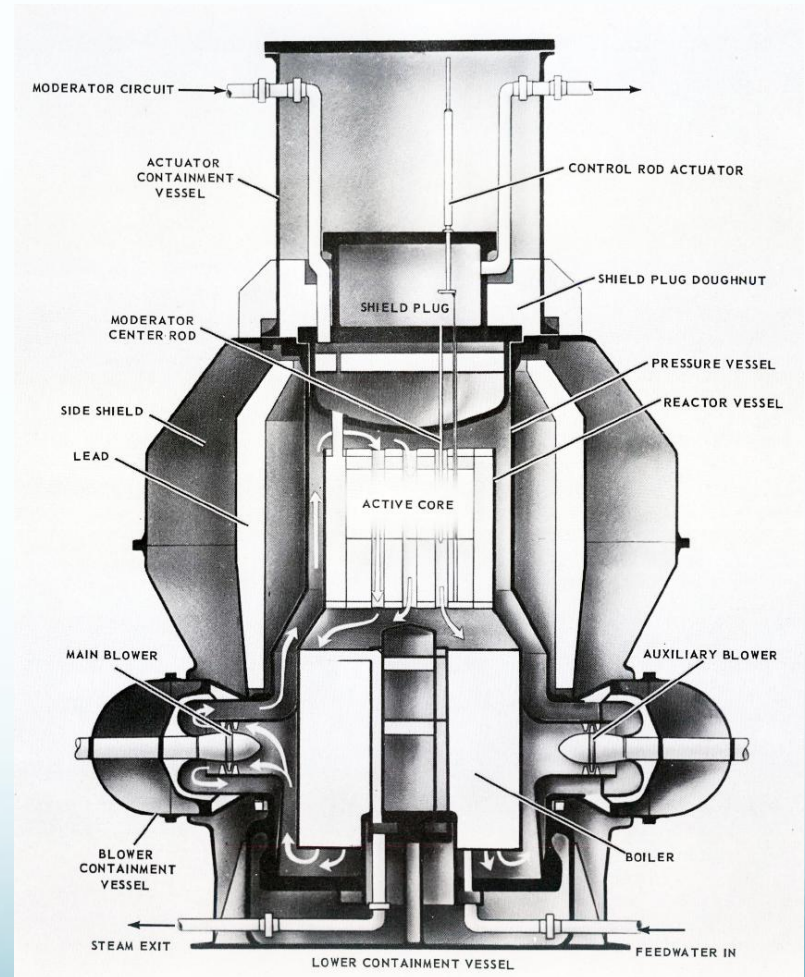

Source: General Electric Report GEMP-175, January 1963

General Electric 630A process flow diagram

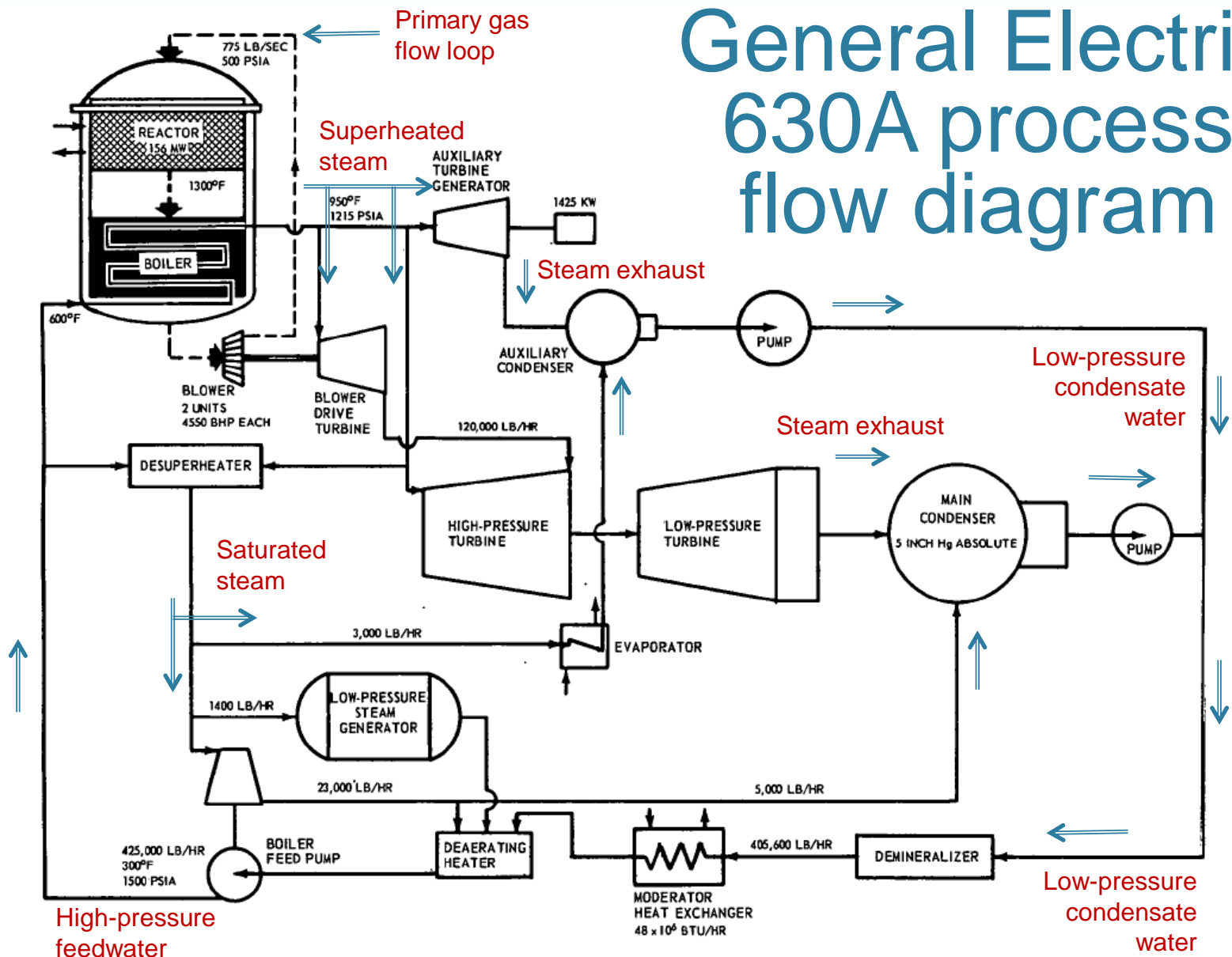

General Atomics Maritime Gas-Cooled Reactor (MGCR) & EBOR

- 1958 – 1963: The goal of the MGCR Project, funded under a joint Atomic Energy Commission - Maritime Administration contract, was to produce a nuclear power plant for commercial maritime use with propulsion power of 22, 000 – 32,000 shaft horsepower
- In June, 1961, the Electric Boat Division of General Dynamics Corporation completed its studies of the plant arrangement for the MGCR and other propulsion-system equipment
- Reactor trade studies initially selected a graphite-moderated, helium-cooled reactor but ultimately focused on a beryllium oxide moderated and reflected, helium-cooled reactor, which was better suited for a small, maritime powerplant.
- MGCR was cancelled in 1963, but work continued under the Experimental Beryllium Oxide Reactor (EBOR) project.
- The EBOR reactor facility was built at the Idaho National Lab (INL), but was not completed before the project was cancelled in 1966. Fuel was never loaded into EBOR.

Maritime Gas-Cooled Reactor (MGCR) process flow diagram

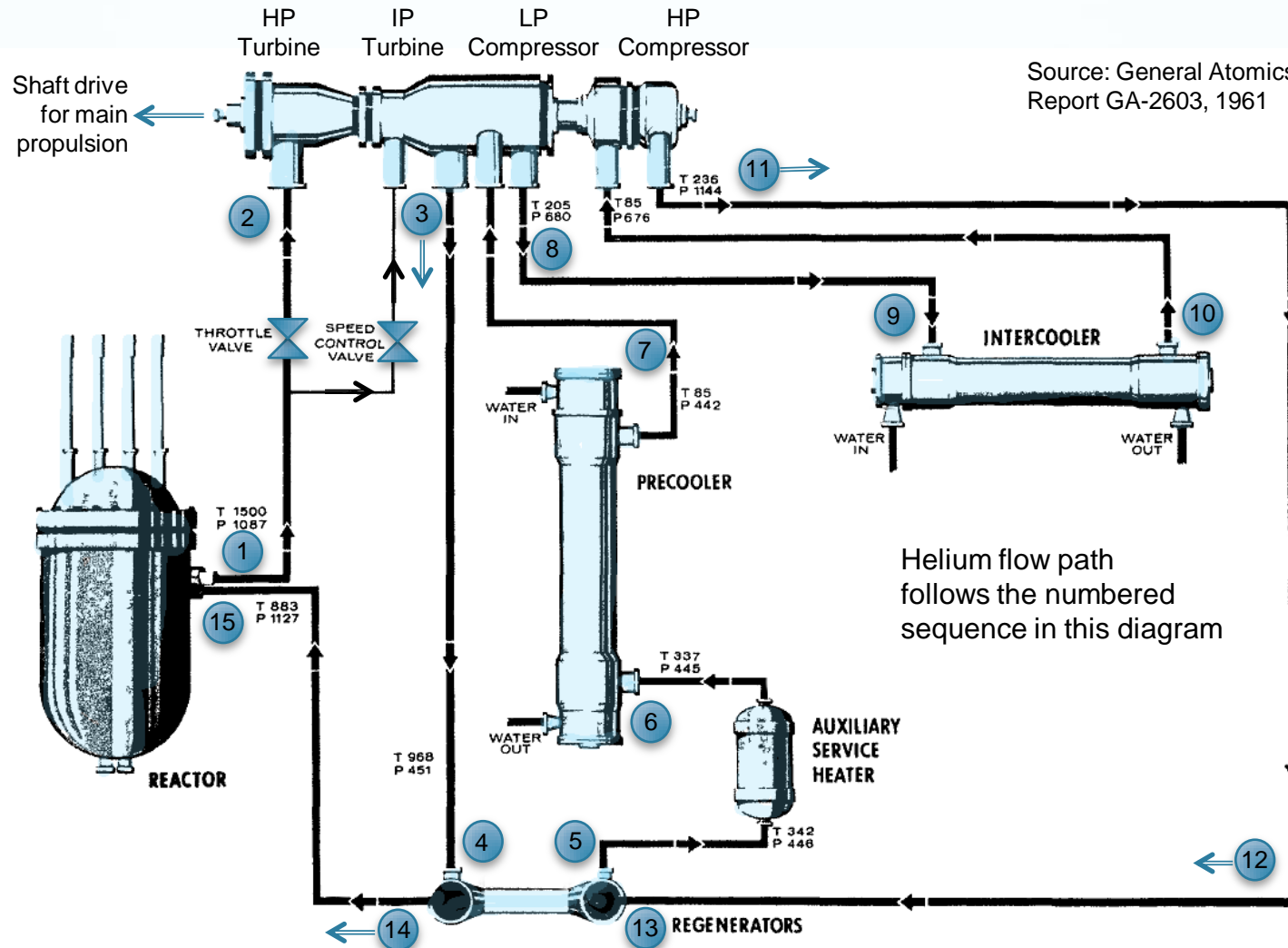

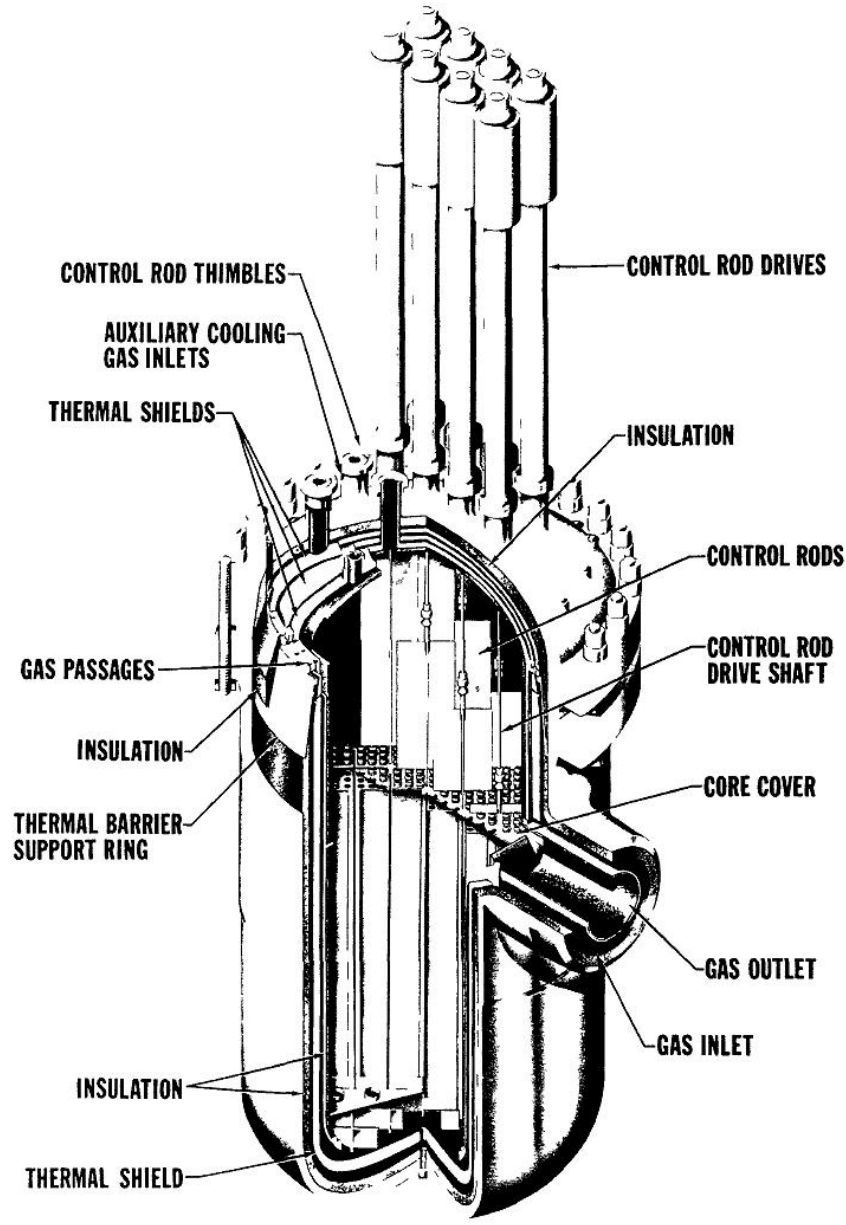

Maritime Gas-Cooled Reactor (MGCR)

Source: General Atomics Report GA-2603, 1961

Other U.S. commercial marine nuclear plant designs

- General Motors Marine
 - 1957 proposed design for a 50 MWt helium gas-cooled reactor, closed-cycle gas turbine system delivering 20,000 SHP for installation in a 38,000 ton DWT tanker.
- Gen4Energy (formerly Hyperion Power Generation)
 - The 70 MWt Gen4 Module (G4M) is a small fast-neutron reactor using lead-bismuth eutectic coolant. It is capable of delivering for about 25 MWe (33,525 shp) for propulsion.
 - Reactor life is 10 full-power years. In marine service, a G4M will last for the typical 25-year operational life of a commercial vessel.
 - 2010 -12: British Maritime Technology and Lloyd's Register conducted a study for a Greek shipping company of the use of a G4M reactor for propulsion of a 155,000 ton "Suezmax" tanker.
 - The study results were published in 2014.
 - The study considered the option of leasing the nuclear power plant.

Radioisotope
thermoelectric
generators (RTGs)
at sea

RTGs at sea

- An RTG is an electric generator with no moving parts. It uses an array of thermocouples to convert heat released from radioactive decay into electricity. The heat source can be one of several radioisotopes.
 - Sr-90 (Strontium 90)-fueled RTGs are the common type of RTG used by the U.S. Navy and /or Coast Guard.
 - Beta (β) emission, with minor gamma (γ) emission; requires considerable biological shielding; 28.8 year half-life; power density 0.46 watts per gram
 - In the late 1970s, the U.S. Navy tested Pu-238 (Plutonium 238)-fueled RTGs. Operational applications are not known.
 - Alpha (α) emission; does not require shielding; 87.7 year half-life; power density 0.54 watts per gram
- The U.S. has employed RTGs in many marine and terrestrial applications where they function as “super batteries”, serving in remote locations as reliable electric power sources with operating lives of 5 to 10 years or more, with no maintenance required.
- Typical marine uses of RTGs include providing power for meteorological and oceanographic sensors and data collection systems, communications systems, navigational aids, and undersea surveillance systems.
- RTGs used in marine applications are the SNAP-7, -21, & -23-series, the Sentinel-25 series, and the Minibatt-1000.

U.S. RTGs at sea

- SNAP-7-series RTGs
 - Fuel element: Sr-90
 - Electrical power generation: 7.5 – 60 watts
 - Pressure hull rating: 10,000 psi
 - Example applications: U.S. Coast Guard buoys & lighthouse; U.S. Navy NOMAD (Navy Oceanographic Meteorological Automatic Device); deep water sonar transducer
- SNAP-21-series RTGs
 - Fuel element: Sr-90
 - Electric power generation: 10 watt and 20 watt versions
 - Pressure hull rating: not known
 - Example applications: powering sonars, boosting underwater cable power, navigational aids, and research instruments.
- SNAP-23-series RTGs
 - Fuel element: Sr-90
 - Electric power generation: 25 watt, 60 watt, and 100 watt versions
 - Pressure hull rating: terrestrial, 0 psi
 - Example applications: surface applications, including powering weather and navigational buoys

SNAP-7 RTG

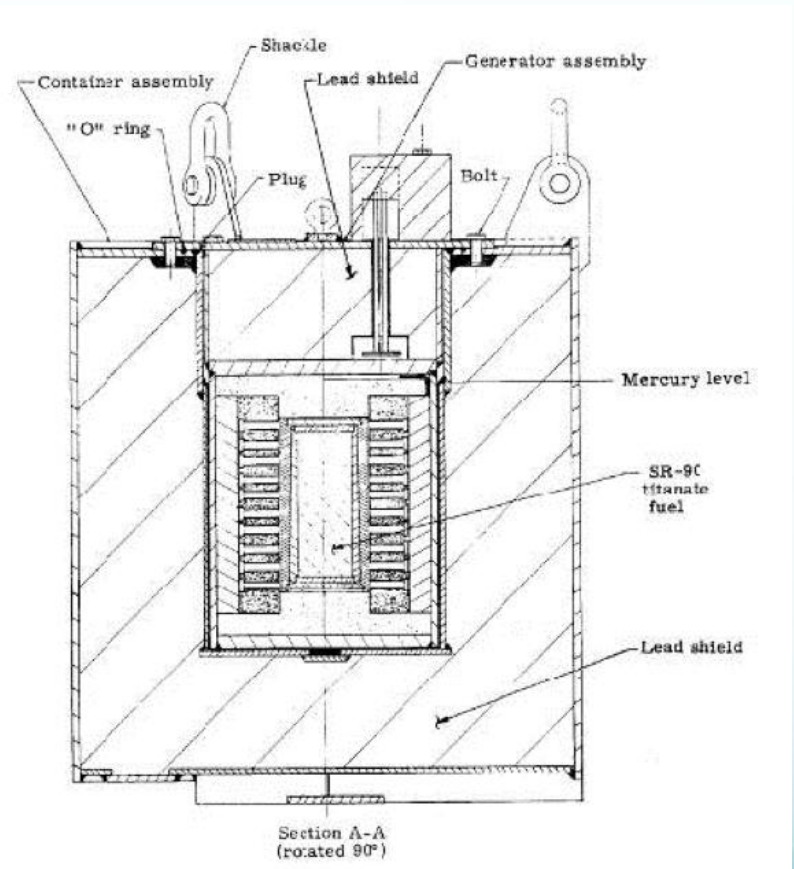

Source: Disposition of Radioisotope Thermoelectric Generators Currently Located at the Oak Ridge National Laboratory – 12232, WM2012 Conference, 2012

U.S. RTGs at sea

- Sentinel-25-series RTG
 - Fuel element: Sr-90
 - Electrical power generation: 25 watts
 - Pressure hull rating: terrestrial, 0 psi (25A); 500 psi (25C3 & 25F); 1,000 psi (25D); 6,000 psi (25C1); 10,000 psi (23E)
 - Example applications:
 - Navy's Inter-Seamount Acoustic Range (ISAR) transmitter at a depth of 2,200 ft;
 - Wave Gage System in Gulf of Mexico (3 RTGs in series to provide 60 watts); drum-type data buoy system (BEAR Buoy)
- Millibatt 1000
 - Fuel element: Sr-90
 - Electrical power generation: 25 watts
 - Pressure hull rating: 10,000 psi
 - Example application:
 - Air Force Deep Ocean Transponder Systems (geodetic reference points) on the Eastern Missile Test Range.

Example RTGs installations for deep-water buoy applications

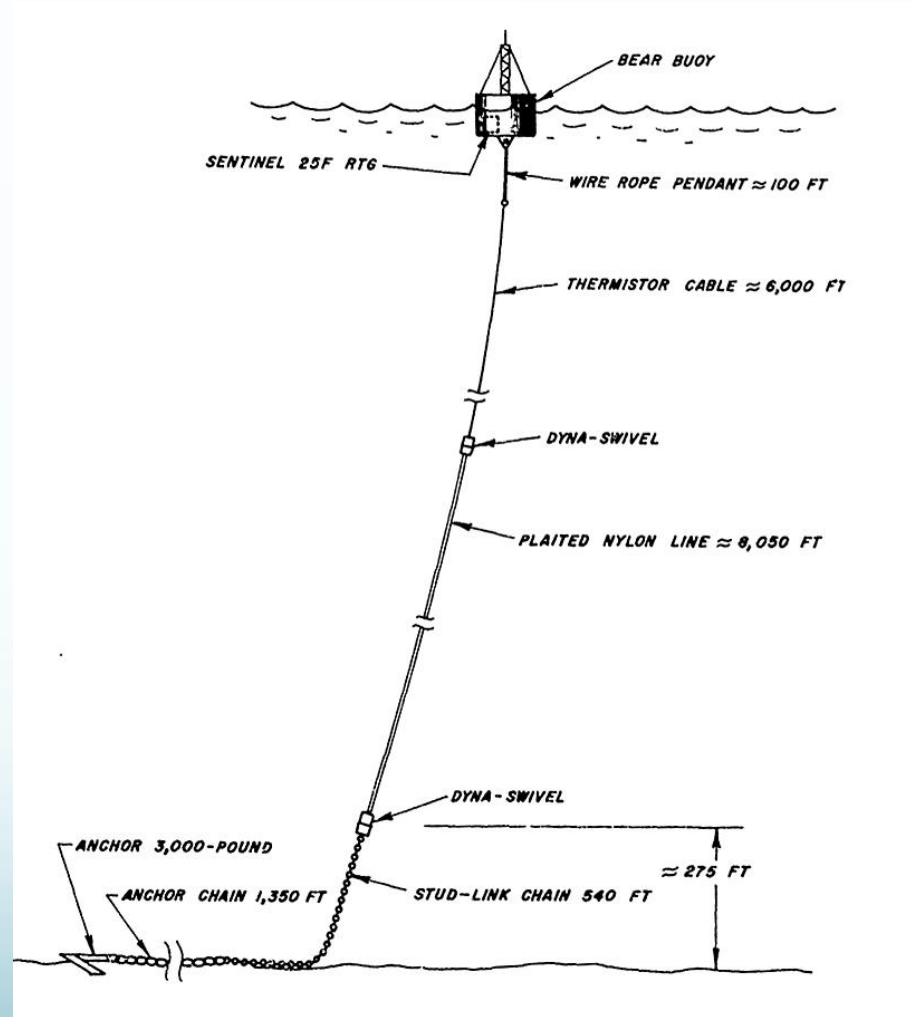
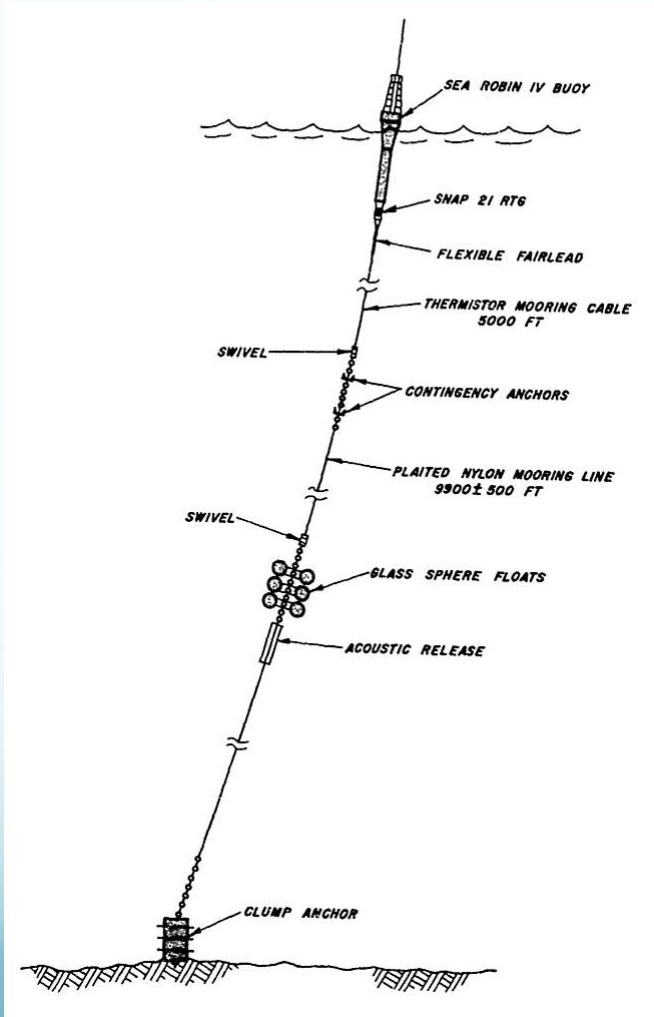

Source: Radioisotope Thermoelectric Generators of the Navy, Naval Nuclear Power Unit, Port Hueneme, 1 July 1978

**U.S. marine
nuclear power
current trends**

U.S. current trends

- New build:
 - Virginia-class SSN new-build program continues with Blocks IV boats
 - 2012: the Congressional Budget Office (CBO), stated that 33 Virginia-class submarines will be procured in the 2013 – 2032 timeframe, for a total of 49 subs in this class.
 - 28 April 2014: General Dynamics Electric Boat was awarded a \$17.6 billion prime contract for ten Block IV Virginia-class attack submarines.
 - As of mid-2015, the Navy has agreed the design of the Block V boats, but procurement of Block V boats has not started.
 - Gerald R. Ford-class CVN new-build continuing with the second new CVN
 - 5 June 2015: Huntington Ingalls Industries received a \$3.35 billion prime contract for the detailed design and construction of the nuclear-powered aircraft carrier *John F. Kennedy* (CVN 79).
 - New-build rate is expected to be one CVN every four years.
- Phase-out / replacement:
 - Retirement of Flight I Los Angeles-class SSNs, which do not have a vertical launch system (VLS), will continue. Retirement of 688 Flight II and 688i boats is not expected to start until the early 2020s. The Los Angeles-class SSNs are being replaced by new-build Virginia-class SSNs.
 - *USS Gerald R. Ford* (CVN-78) replaces *USS Enterprise*, which was retired in 2012. Subsequent Ford-class CVNs will replace Nimitz-class CVNs on a 1-for-1 basis.
 - Ohio-class SSGNs will retire starting in the mid-2020s, with the last of four boats retiring by 2029. The replacement SSGN and special operations force (SOF) capabilities will be provided by Virginia Block V multi-purpose SSNs, which are expected to start entering the fleet in the mid-2020s.

U.S. current trends

- Refurbishment / modernization:
 - Reduce the number of missile tubes on Ohio-class SSBNs:
 - To comply with New START, four missile tubes are being removed from each of the 10 Ohio-class SSBN starting in 2015; to be completed by 5 Feb 2018. This removes 40 strategic launchers and a larger number of warheads from the U.S. inventory.
 - Improve submarine communications capabilities:
 - Continue to update existing subs with the “Common Submarine Radio Room”
 - Add “networked communications” capabilities that will improve submarine integration with the surface fleet and aircraft.
 - Add Unmanned Underwater Vehicle (UUV) capabilities:
 - Navy sees UUVs as a cost-effective way to extend the reach of its submarine fleet, and in some cases, to allow the sub to conduct other missions while the drone has its own assignment.
 - Operational use of a “free-flying” UUV from a Block III Virginia-class sub during a military operation first occurred in July 2015
 - Submarine UUV handling capabilities will likely be retrofitted to older subs.
 - Armed UUVs, such as the Naval Undersea Warfare Center MANTA concept
 - Large, flatfish-shaped UUVs mated externally to a “mother” submarine could provide a powerful and flexible adjunct to the combat power of their host.
 - Each MANTA vehicle would carry significant payloads of both sensors and weapons.

Submarine networked communications concept

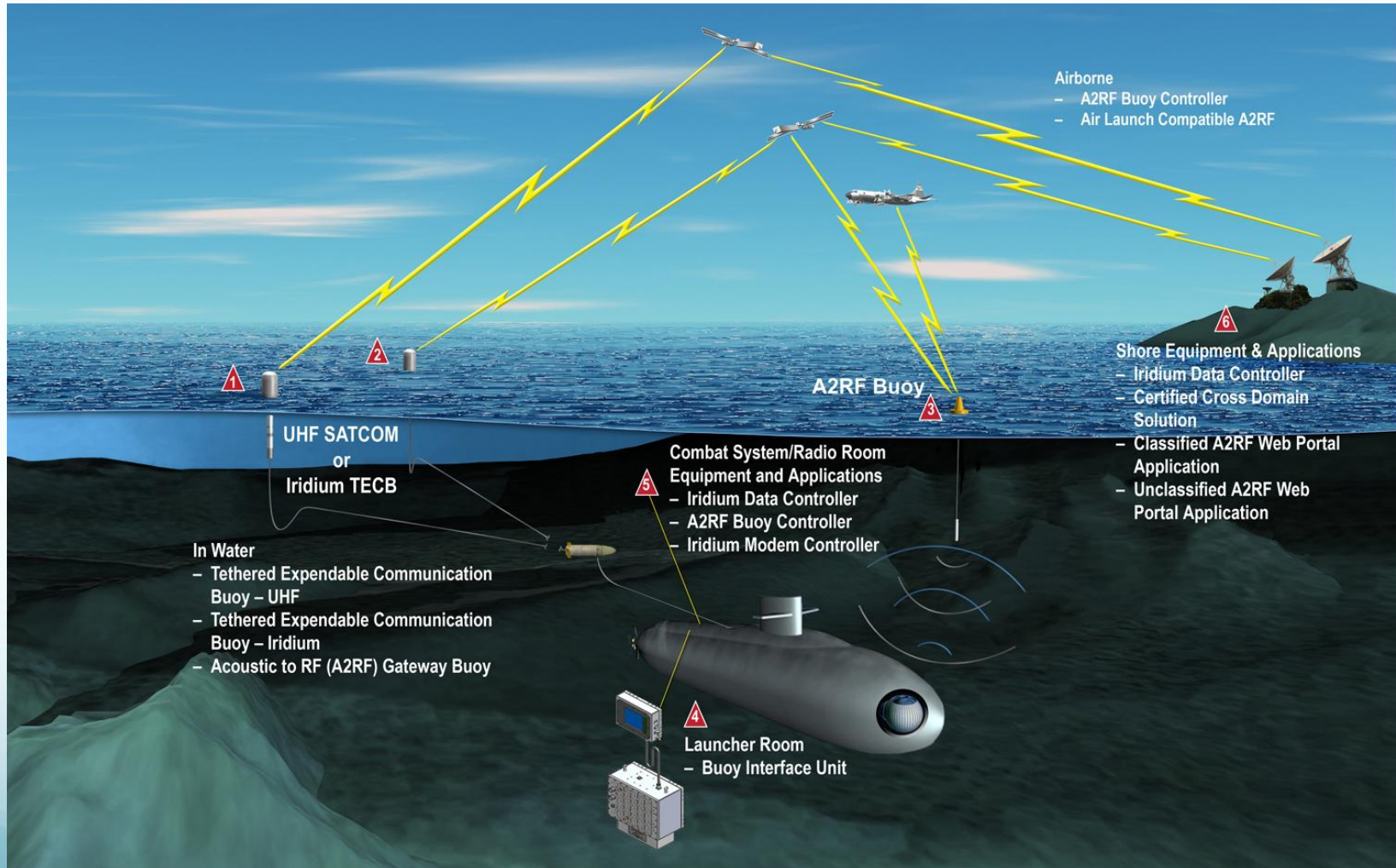

Armed UUV concept

- This large, autonomous UUV concept includes a flexible payload capability such as full-size torpedoes, a greater quantity of lightweight torpedoes, missiles or small UUVs, sensor and communications packages, and towed array sonar.

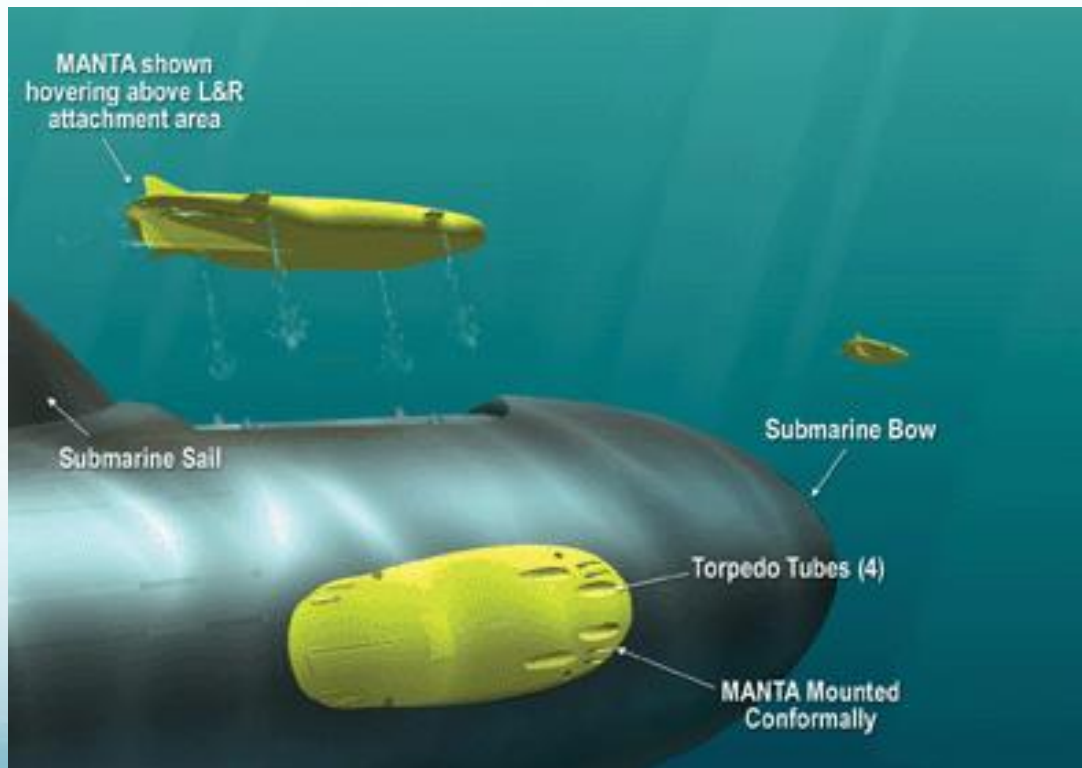

- Mounted conformally on launch & recovery (L&R) sites on the submarine's hull.
- Naval Undersea Warfare Center has been operating a MANTA Test Vehicle (MTV) since 1999 to develop technology and a concept of operations for this class of UUV.

U.S. current trends

- Operations:
 - Constant-size CVN fleet
 - 11 CVNs after *USS Gerald R. Ford* joins the fleet in 2016
 - Smaller SSN fleet
 - Older Los Angeles SSNs are being retired faster than replacement Virginia-class SSNs are being built
 - Smaller SSBN fleet
 - The first of 14 Ohio-class SSBN, each with 24 SLBMs, is expected to retire in 2029.
 - The first of 12 Ohio replacement SSBN, each expected to have 16 SLBMs, is planned to enter the fleet in 2031.
 - Significant decline in the number of SSGN tactical weapons
 - The first of four Ohio-class SSGNs, each capable of carrying 154 Tomahawk cruise missiles or similar sized weapons, will start retiring in the mid-2020s, with the last boat retiring by about 2029.
 - The first of the new Block V Virginia-class multi-purpose SSNs, each capable of carrying 40 Tomahawk cruise missiles or similar sized weapons, will start entering the fleet in the mid-2020s.
 - With the retirement of the Ohio-class boats, the fleet will lose the Ohio SSGN's unique capability to operate as a Small Combatant Joint Command Center.
 - Good capabilities to support special operations forces (SOF)
 - A Virginia-class SSN has better SOF capabilities than a retiring Los Angeles-class SSN; but can't match the capabilities for a large SOF contingent like the Ohio-class SSGN.

U.S. current trends

- New submarine development
 - Ohio SSBN-replacement program has been initiated
 - The U.S. is collaborating with the UK to co-develop elements that are common with their Successor submarine (Vanguard-replacement) program.
 - Lead ship to make its first deterrent patrol in 2031.
 - SSN(X)/Improved Virginia program has been initiated
 - Procurement of the first submarine has been pushed back to 2033/2034
- New marine reactor development
 - Development of the Transformational Technology Core (TTC) is in progress.
 - The primary design goal for the TTC is delivering 30% more lifetime energy, while still fitting in the S9G reactor vessel used in the Virginia-class submarine.
 - Development work for the reactor that will power the Navy's next generation SSBN was fully funded in the 2015 budget.
 - This reactor is required to last the life of the SSBN refueling
 - Continued use of HEU fuel.

U.S. current trends

- New weapons system development
 - Prompt Global Strike (PGS)
 - This is a system than is intended to deliver a precision conventional warhead to strike any point in the world within 1 hour of launch
 - Feb 2014 – Navy solicited bids for a 2-year industry trade study for a submarine-launched, intermediate-range, hypersonic, conventional warhead PGS weapon.
 - An adversary will need to be able to distinguish between a conventional PGS strike and a nuclear SLBM strike, otherwise use of a conventional PGS weapon could escalate a conflict between nuclear powers.
 - Trident II (D5) replacement
 - The current Trident D5LE (life-extension) version is expected to remain in service until 2042. There is no active replacement program.
- Technical support to other nations
 - The U.S. and UK are collaborating on common elements of the Ohio-replacement program and the UK's Successor submarine (Vanguard replacement) program
 - The new Rolls-Royce PWR3 nuclear reactor for the Successor submarine will be 'based on a modern U.S. plant' and U.S. support will be provided.
 - A likely candidate is the S9G reactor used on Virginia-class subs.

U.S. current trends

- Final disposition of retired naval nuclear vessels
 - The existing NSSRP program will continue managing the disposition of retired naval vessels at the Puget Sound Naval Shipyard.
 - On-going processing of retired nuclear submarines.
 - A new near-term challenge will be processing the 1st nuclear-powered aircraft carrier, *USS Enterprise*, which was decommissioned in 2012.
 - The next CVN to be retired will be *USS Nimitz*, which will reach its 49 year design operating life in 2024.
 - Naval Reactors is planning a major update and expansion of the capabilities at the 50-year old Expanded Core Facility (ECF) at the Naval Reactors Facility (NRF) in Idaho
 - New shipping casks needed + updates to the ECF are needed to handle the longer fuel elements from aircraft carriers
 - All spent nuclear fuel must be in dry storage by 2023 and removed from Idaho by 2035.
 - NR is developing a plan for longer-term safe management of naval spent fuel and nuclear waste.

U.S. current trends

- Final disposition of retired civilian nuclear vessels
 - *Sturgis* floating nuclear power plant defueled in 1977. Decommissioning and scrapping is expected to be completed in 2016.
 - *NS Savannah* defueled in 1975. Ship will remain in a state of “maintained storage”, awaiting funding for final cleanup, decommissioning and a possible future role as a museum ship.
- On-going infrequent monitoring of two sunken U.S. nuclear submarine deep-water sites; currently with no indication of significant radioactive contamination of the ocean environment:
 - *USS Thresher* (SSN-593), sank off Cape Cod, at a depth of 2,560 m (8,400 ft)
 - *USS Scorpion* (SSN-589), sank in the mid-Atlantic, at a depth of 3,000 m (9,800 ft)