

3G222 MK 2

Double throw pass lock for secure perimeters with a unique magnetic key locking system which makes it impossible to sight read the key

Features

- Twin key double throw bolt action
- Heavy duty steel body
- Operation by a magnetic key which makes it impossible to sight read
- 2,000 effective differs achieved by four individual magnetic rollers per barrel
- Steel dead bolt rotors
- Anti-padsaw steel rollers
- Escutcheon provides positive key location
- Anti-tamper device to prevent unauthorised removal
- Two layer face plate for extra mounting strength
- Handle variations available
- Re-code, quick change mechanism (Exclusively to Chubb)

ANTI-PADSAW ROLLERS



UNIQUE MAGNETIC KEY



TWO LAYER FACE PLATE

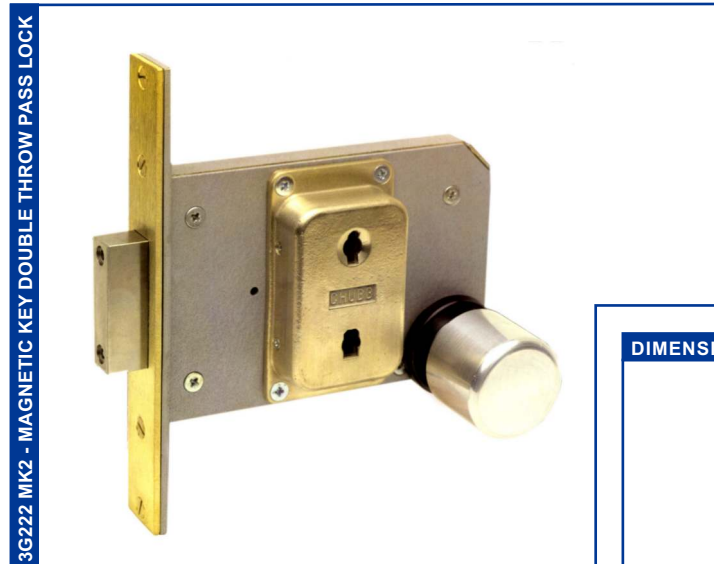

DIMENSIONS

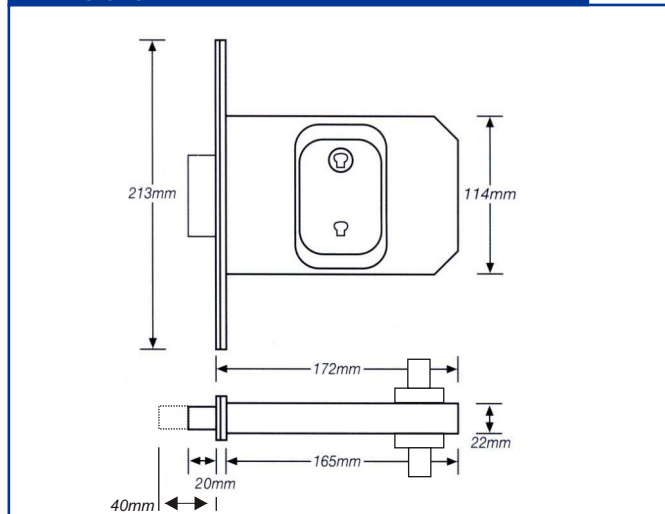

DURABILITY TESTING

Key Operations	500,000
Handle Operations	1,000,000
Saw Attack	30 minutes
Salt Spray	96 hours

ORDERING AND INSTALLATION

This lock should not be fitted to a wooden door less than 54mm thick. When fitting to steel doors and grille gates the lock must be ho used with in the special outer steel box which is welded to the gates. For steel faced doors the outer steel box can only be fitted during the door

man ufa ctu re stage and there fore must be ordered well in advance. This literature is designed as a guide to the extensive range of CLCS products. Please contact our sales department before ordering to ensure you have the correct specification for your application.



UK Telephone
Int Telephone
Email
Website

Chubb Locks Custodial Services Ltd
Well lane, Wolverhampton, WV11 1TB, United Kingdom
01902 867730
00 44 1902 867730
sales@clcsLtd.co.uk
www.clcsLtd.co.uk

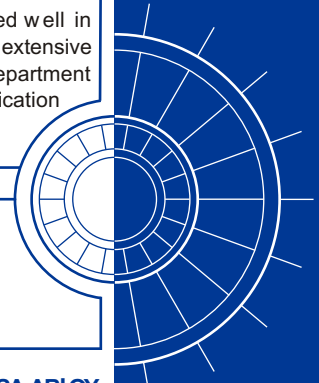

3G222 MK2 - MAGNETIC KEY DOUBLE THROW PASS LOCK